

TL
232
.S56
1981





FOREWORD

As part of its ongoing commitment to the principle of technology sharing, the U.S. Department of Transportation has initiated a series of publications based on research-and-development efforts sponsored by the Department. The series is comprised of technical reports, state-of-the-art documents, newsletters and bulletins, manuals and handbooks, bibliographies, and other special publications. All share a primary objective: to contribute to a better base of knowledge and understanding throughout the transportation community, and thereby, to improve the basis for decision-making within the community.

This document presents both an update and expansion of a 1975 Technology Sharing document which profiled small transit vehicles. This document presents information on the vehicles available and on the selection, procurement, and operational considerations of using small transit vehicles in a transportation service.

The information contained in this document is drawn from over 100 sources including conversations with transportation system operators, state and local planners, and vehicle suppliers. It is intended to be used as a guide to assist providers of transportation services, and community and state planners, in the selection and use of small transit vehicles. Included in this document is supplementary material serving as a sourcebook for further information.

09446

PL
232
.S56
1981

ACKNOWLEDGMENTS

This report is jointly sponsored by the following organizations:

- OFFICE OF THE SECRETARY
Office of Assistant Secretary for Governmental Affairs
- TRANSPORTATION SYSTEMS CENTER
Technology Sharing Program Office
- URBAN MASS TRANSPORTATION ADMINISTRATION
Associate Administrator for Technology Development
and Deployment

A special acknowledgment is made to the many State and local government transportation officials who participated in the process and made this document the product of a true Federal, State, and local government partnership.

CONTENTS

I OVERVIEW , page 1

- What are Small Transit Vehicles? , page 1
- Service Roles of Small Transit Vehicles , page 3
- Advantages in Using Small Transit Vehicles , page 3
- Nature of the Market , page 5

II SELECTION , page 11

- Types of Vehicles , page 12
- Experience with Specific Vehicle Components , page 17
- The Need for Backup Vehicles , page 33
- Uniformity of the Fleet , page 34

III PROCUREMENT , page 35

- Acquisition from an Existing Stock , page 35
- Leasing , page 35
- Purchasing , page 36
- Funding Sources , page 48

IV OPERATIONAL CONSIDERATIONS , page 51

- Financial Considerations , page 51
- Maintenance , page 56
- Driver Training , page 62
- Insurance , page 63

V CONCLUDING COMMENTS , page 67

REFERENCES , page 69

GLOSSARY , page 75

SUPPLEMENTARY MATERIAL

APPENDIX A: Manufacturers of Small Transit Vehicles

APPENDIX B: Manufacturers of Wheelchair Lifts and
Ramps and Wheelchair Securements

APPENDIX C: Major Federal Funding Sources

APPENDIX D: Sample Vehicle Inspection and Maintenance Forms

APPENDIX E: Outline for Writing Technical Specifications

APPENDIX F: Life-Cycle Costing Method

APPENDIX G: Small Transit Bus Profiles

FIGURES

- 1 Types of Vehicles , *page 2*
- 2 Typical Costs per Vehicle Kilometer for Fixed Route Rural Transportation in the Northeast and Mid-Atlantic Regions (FY 1977) , *page 6*
- 3 Factors Affecting Vehicle Selection , *page 10*
- 4 Dimensions for Vans, Modified Vans, Body on Chassis, and Small Buses (1980 Vehicles), *page 12*
- 5 Typical Construction of a Body on Chassis , *page 14*
- 6 Bus Width Limits , *page 17*
- 7 Aisle Space Requirements for Various Users , *page 19*
- 8 Typical Seating Arrangements for Standard Vans and Modified Vans , *page 21*
- 9 Typical Seating Arrangements for a 12-Passenger Body on Chassis, 20-Passenger Body on Chassis, and Small Bus, *page 23*
- 10 Basic Components of a Van Chassis , *page 27*
- 11 Recommended Safety Features for Use of Wheelchair Lifts , *page 31*
- 12 Price Ranges for Ramps and Wheelchair Lifts (in Dollars), *page 32*
- 13 Leasing Versus Purchasing — Sample Cost Comparison , *page 37*
- 14 Vehicle Procurement Flow Chart (Urbanized Area Grant Programs), *page 39*

15	Vehicle Procurement Flow Chart (Nonurbanized Area Grant Programs), <i>page 40</i>
16	Sample Advertisements (Invitations for Bids), <i>page 41</i>
17	UMTA's Required Clauses and Provisions for Equipment Contracts, <i>page 42</i>
18	Typical Bid Process, <i>page 43</i>
19	Sample Bid Process Timeline, <i>page 44</i>
20	Computing Life-Cycle Costs, <i>page 47</i>
21	Vehicle-Related Cost Items, <i>page 52</i>
22	Vehicle Price Ranges, <i>page 52</i>
23	Transportation Costs of 56 Systems Providing Transportation for Elderly and Handicapped People, <i>page 54</i>
24	Sample Ranges of Unit Costs for Rural Transportation Systems, <i>page 55</i>
25	Motorbus Diesel Fuel Costs, <i>page 57</i>
26	Examples of Work That May Be Performed by Outside Agencies, <i>page 58</i>
27	Components of a System for Maintenance Planning, <i>page 59</i>

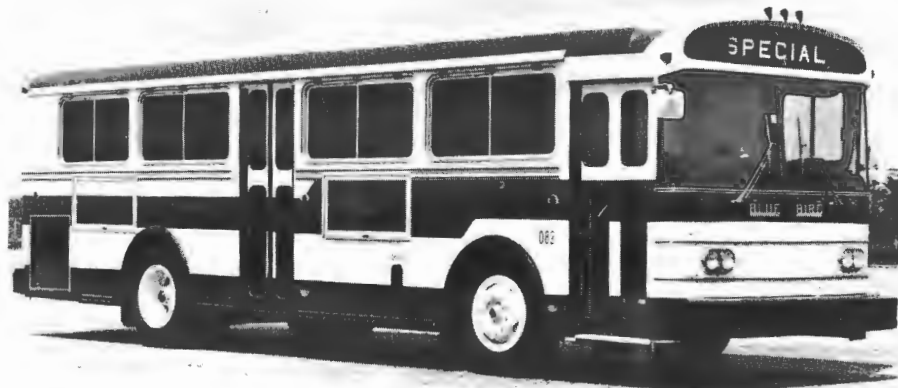

I | OVERVIEW

what are small transit vehicles?

IN RECENT YEARS, there has been a growth of transportation services offering an alternative to the scheduled, fixed-route services available in urban areas. In addition, public transportation services are beginning to appear more often in nonurban areas. These developments have increased the need for vehicles other than the standard 40-foot transit bus. Small transit vehicles have lower seating capacities, greater maneuverability, and capital costs which are within the financial capabilities of the operators of these new services.

This report is a state of the art of small transit vehicles. It provides an informational overview directed toward new or future service planners and operators of small vehicles. This report describes:

- The vehicles available and the considerations involved in their selection (Chapter II)
- Alternative procurement processes, concentrating on purchasing through the use of a bid process (Chapter III)
- Financial and operational considerations, including costs, maintenance, driver training, and insurance (Chapter IV).

However, it should be pointed out that the state of the art is constantly evolving as the available vehicles, and the uses to which they are put, evolve. Much of the existing information, unfortunately, is generally not available in journal articles nor in reports, but is rather in the minds of those who have had experience using small transit vehicles. Therefore, once the reader has reviewed this state-of-the-art document, it is recommended that he contact experienced operators to further increase his knowledge of the successful use of small transit vehicles.

The expression "small transit vehicle" generally refers to a vehicle smaller than the 40-foot standard transit bus; this is its meaning in this document. However, within the group of small transit vehicles there are a number of different types and sizes. The terms used for the subgroups of small transit vehicles are not standard. This report discusses the vehicles in groups according to their method of construction. (See Figure 1.) These are:

Figure 1. Types of Vehicles

Standard Van

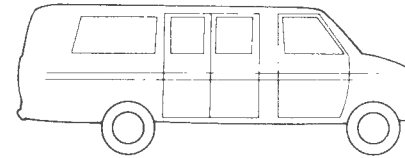

Modified Van

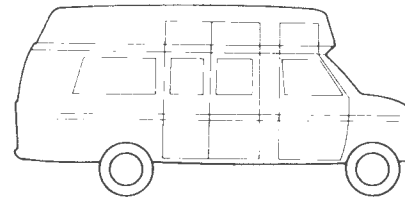

Body on Chassis

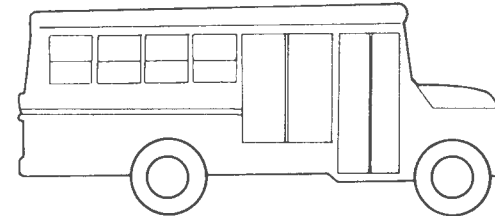

Small Bus

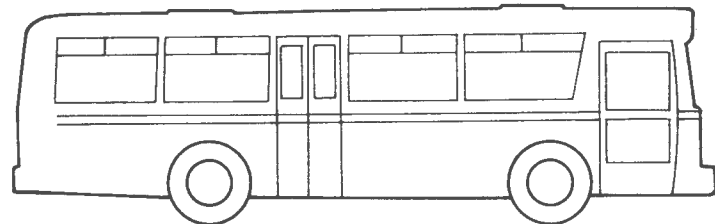

- Standard van — the vans available from automotive manufacturers
- Modified van — standard vans with some body and/or chassis modification; available from the modifier
- Body on chassis — a “marriage” of a light truck chassis and a body, available from the body manufacturer
- Small bus — a bus whose chassis and body are designed as an integral unit durable in transit service; available from the small bus manufacturer.

These vehicles are described further in Chapter III. Chapter III also briefly discusses other vehicles, such as school buses which are currently used in transportation services.

service roles of small transit vehicles

SMALL TRANSIT VEHICLES are currently being used in a variety of transportation services:

- **Fixed-route services** with regular routes and schedules. Small urban and rural areas usually do not have ridership levels warranting the use of a regular transit bus commonly used in urban fixed-route services.
- **Shuttle services** which operate along heavily traveled corridors such as those in urban centers, large commercial mall areas, and airports.
- **Feeder services** which provide transportation to and from a regular transit route.
- **Demand-responsive services** which are characterized by flexible routing and scheduling to provide shared occupancy on demand, often with door-to-door service. Demand-responsive services are often provided for people whose mobility is limited due to age, or physical, mental, or emotional disabilities.
- **Pre-arranged ride-sharing services** which include van pooling and subscription buses that operate mainly during peak times to provide commuters who have predetermined work schedules the opportunity to share vehicles. These services are also provided by human service agencies for their own clients.

advantages in using small transit vehicles

There are several reasons small transit vehicles are better suited than standard transit buses for use in the services listed above.

MANEUVERABILITY. A study of transportation services using small vehicles found maneuverability to be a major factor in the decision to buy small vehicles (84).* In many cases, because of street structure and local terrain, maneuverability is of prime importance. Small vehicles, because of their shorter turning radii, can maneuver more easily on narrow roads and around sharp corners. Limited curb space for stops is less of a problem with small vehicles (89). Additionally, some transit services require vehicles to drive into driveways and to back out; this is facilitated with small vehicles.

Small vehicles are also easier to drive; this has the advantage of increasing the availability of eligible drivers and decreasing the training needs. In addition, depending on state law, licensing requirements for drivers of small vehicles may not be as strict as those for drivers of large vehicles.

COST. In a cost comparison between vehicles of different sizes it is possible to distinguish between the capital costs (costs of buying the vehicle) and the operating costs (costs of running the vehicle).

1. Capital Costs

Although the initial cost of a small vehicle is usually lower, it is not always true that the annual costs are substantially lower. Given the shorter life span of a smaller vehicle, the annual capital cost (including depreciation and finance costs) over the life of a smaller vehicle may not vary from larger vehicles (34).

2. Operating Costs

The major components of operating costs are drivers' wages, fuel, and maintenance.

Drivers' wages may or may not be affected by the size of a vehicle, despite the fact that drivers of small vehicles may not require the same driving skills as drivers of large vehicles. If a large number of small vehicles is used to meet the demand that fewer large vehicles could meet, additional drivers may be required.

In considering *fuel costs*, it should be noted that small vehicles generally achieve a higher number of miles per gallon than large vehicles. However, most small vehicles use gasoline which is priced higher than the diesel fuel used by large vehicles.

A survey of bus transit operations found that although *maintenance costs* for small vehicles may be lower on the average, the size of the operation ultimately determines the impact of lower maintenance costs of small vehicles (84). A small transit operation can avoid a large maintenance facility outlay by contracting out for

*Numbers in parentheses refer to References.

service. If the vehicle is a standard van or has a mass-produced chassis, parts and service may not be difficult to obtain. However, some of the larger operations surveyed feel that small vehicle maintenance costs are higher because the addition of small vehicles requires a larger parts inventory, special facilities, and mechanic retraining. As a result, these large operations claim that repair costs per service mile for small vehicles are higher than those for standard-size buses.

3. Total Costs

However, when examining total costs, it is instructive to look at a 1977 study of fixed-route rural transportation in the Northeast and Mid-Atlantic regions which determined typical costs per vehicle kilometer. (See Figure 2.) (11). From this figure it can be concluded that, with the exception of school buses, capital and operating costs increase as vehicle size increases. However, the findings also indicate that as vehicle size increases, costs per seat kilometer decrease. Therefore, it is most cost effective to use a vehicle whose capacity corresponds to the ridership level. In other words, when passenger demand is low, or the routing or scheduling of a service is such that a large number of passengers cannot be accommodated at one time, a small vehicle is more cost effective than a large vehicle.

RESIDENTIAL PREFERENCE. In residential areas, small vehicles may be preferred. Large transit buses are generally noisier, because they have diesel engines. (However, local sentiment with respect to size, noise, the impact on real estate values, etc., varies with the locality (46).) In addition, small transit-vehicle operations may attract passengers who have negative feelings towards large transit buses (34).

nature of the market

The small vehicle market is characterized by fragmented, low, and uncertain demand. The supply side of the market is in constant flux because suppliers are constantly entering and leaving the market (117).

As mentioned earlier, there are a number of service roles for small transit vehicles and, thus, there are a variety of different users for small vehicles. These users request vehicles tailored to their own services and clients, and they often place small orders. The uncertainty of demand stems primarily from the vehicle users' reliance on outside sources of funds. For example, with Federal funding sources it is difficult to predict:

- The continuation of funding programs
- Which transportation systems will receive funding
- The amount of time between a system's application and its approval

Figure 2. Typical Costs Per Vehicle Kilometer for Fixed-Route Rural Transportation in the Northeast and Mid-Atlantic Regions (FY 1977)¹

Category	Automobile or Station Wagon	Van	Transit Bus			School Bus
			Small	Medium	Large	
Number of adult seats	8	12	20	30	50	44
Operating speed, kilometer/hour (km/h) ²	30	25	18	18	15	15
Cost per vehicle kilometer, in dollars						
Fuel	0.032	0.043	0.057	0.050	0.060	0.057
Oil	0.002	0.002	0.0025	0.0025	0.003	0.0025
Tires and tubes	0.004	0.006	0.012	0.014	0.031	0.025
Vehicle repairs and maintenance	0.028	0.043	0.056	0.077	0.093	0.087
Drivers wages and fringe benefits	0.085	0.102	0.142	0.142	0.170	0.170
Dispatcher wages and fringe benefits	—	—	—	—	—	—
Insurance	0.018	0.025	0.037	0.049	0.062	0.049
Maintenance of dispatching equipment	—	—	—	—	—	—
Driver examination, training, licenses, and tags	0.002	0.0025	0.005	0.007	0.012	0.012
Vehicle storage costs	0.012	0.012	0.012	0.012	0.012	0.012
General and administrative expenses	0.057	0.074	0.102	0.111	0.139	0.130
Vehicle capital costs	0.039	0.065	0.079	0.120	0.189	0.053
Dispatching equipment capital costs	—	—	—	—	—	—
Total Costs	0.281	0.375	0.505	0.587	0.772	0.599

Notes: ¹Fleet size: five vehicles, 40,322 km (25,000 miles) of annual operation per vehicle, 10 percent discount rates.

²1 km = 0.62 mile

Source: Reference 11.

- Whether Federal regulations will delay the funding process. (For example Section 13(c) the Urban Mass Transportation Act of 1964, as amended, (101) requires written assurance by the grant recipient that the interests of employees affected by such assistance will be protected. Obtaining employee approval of these assurances may require months of negotiations which could delay the ordering of vehicles.)

The variety of suppliers includes manufacturers of school buses, mobile homes, recreational vehicles, and other transit vehicles. They often use the same chassis utilized in their standard production line, but with bodies designed for transit service. The rapid movement of suppliers in and out of the market has made it difficult for buyers to identify sellers and to feel secure that a seller will stay in business long enough to honor warranty agreements and to ensure future parts availability. In addition, since many small vehicles have been in use only a short time, operators are not as familiar with the performance characteristics of these vehicles. Some of the vehicles which were in operation for several years are no longer being manufactured. (For example, of the 16 small transit vehicles profiled in a report written by this office in 1975, 13 are no longer manufactured (113).) In those cases, the manufacturers have either gone out of business, stopped producing small vehicles, or developed a different model.

Small buses, the largest type of vehicle discussed in this report, are relatively new and represent an attempt to combine the durability of a standard transit bus with the advantages of a small vehicle. However, unlike small buses, the standard and modified vans and body-on-chassis vehicles are not designed for the operating demands of transit service. Van chassis and the light truck chassis used for body-on-chassis vehicles are designed more for private use. This need for durable small transit vehicles has been discussed for the past few years. Durability was one of the issues addressed at a workshop on small buses held in 1978 (117).

One of the conclusions of this workshop was that development time for a durable small bus could range from nearly four years for an integrated design to less than three years for a body-on-chassis small bus. The cost of developing a new small bus could range from \$1 million for a bus chassis to more than \$10 million for a sophisticated integrated design. Tooling for either small bus could cost several million more, depending on the number of new components required and on the assembly techniques.

In 1977, the Urban Mass Transportation Administration (UMTA) sponsored a study to design a 24- and a 26-foot heavy duty bus chassis (94). The development of a chassis, rather than of an integrated bus was preferred, given the limited market for a small bus and the higher costs of an integrated bus. It was hoped that a

chassis produced by two or three manufacturers would enable body manufacturers to produce a wider choice of buses than would be possible with the development of the integrated bus. Developing a bus body is less costly than developing a chassis, especially when the body is designed to be mounted on a chassis. However, at the time, none of the manufacturers shown the design were willing or able to produce the chassis.

A workshop held by the Transportation Research Board in 1979 estimated the national market for small transit vehicles to be from 5,000 to 10,000 units a year **(41)**. The workshop participants felt that without a more supportive national policy to increase demand, their demand estimate was too low to encourage larger-scale production.

Figure 3. Factors Affecting Vehicle Selection

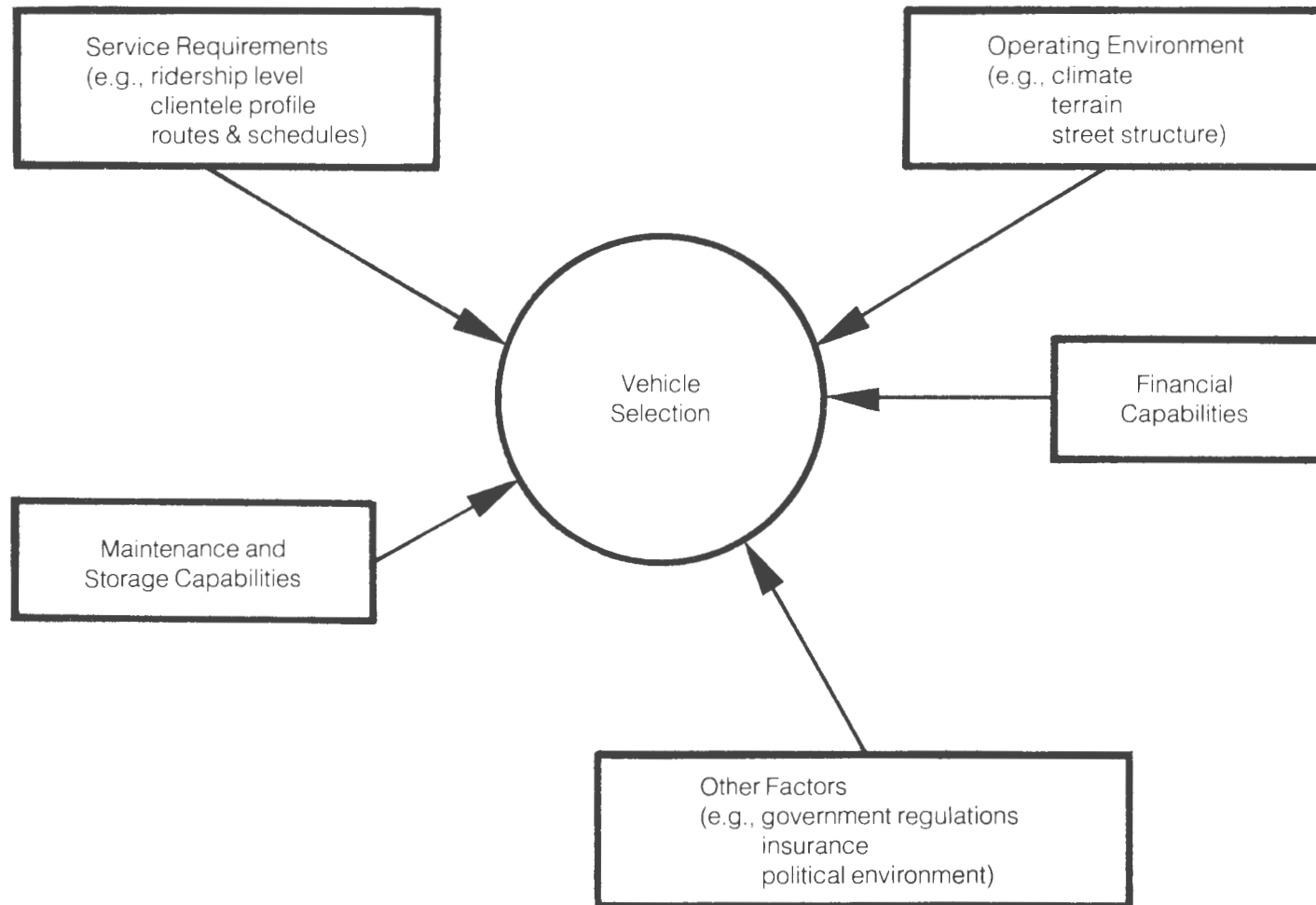

II | SELECTION

THIS CHAPTER CONTAINS a description of the vehicle types and a list of major vehicle components; these vehicle types and components are discussed in terms of the operating data available. There is no discussion of specific vehicle makes for which performance data is so limited that no conclusions can be drawn. However, Appendixes A and B contain a list of manufacturers of small transit vehicles, of wheelchair lifts and ramps, and of wheelchair securements. The discussion of vehicle components is general and deals with small transit vehicles as a group.

With the exception of standard vans, small transit vehicles are made to order. Therefore, a system operator ordering a vehicle can specify that certain aspects of the vehicle be tailored to the system's requirements. For example, passenger accessibility may be a major requirement. Because many small transit vehicles are used in the transport of elderly and handicapped people, and because the U.S. Department of Transportation (DOT) is committed by law (the National Rehabilitation Act of 1973, Section 504) to ensure accessible transportation, considerations of passenger accessibility appear when vehicle components are discussed. There are various kinds of functional disabilities a person can have resulting from age, disease, or injury. The functional disabilities which impact on vehicle design are those which affect an individual's ability to enter and leave a vehicle, to move within the vehicle, and to be comfortable while the vehicle is in motion.

However, despite the fact that accessibility and other transit system requirements are important, a buyer does not have complete control over vehicle design. A buyer must investigate which aspects of a vehicle are standard and which are optional. This can be done by talking with vehicle manufacturers and suppliers.

types of vehicles

To simplify the discussion of the large number of small transit vehicles available, the vehicles are grouped into a few categories. This grouping is based upon the construction method, the source of the vehicle (i.e., how and where the vehicle is assembled), and the seating capacity. Although seating capacity follows a general pattern (i.e., small buses seat more than body on chassis, which seat more than modified vans, which seat more than standard vans), there is some overlap among the categories. Figure 4 contains typical dimensions of the vehicle types.

Figure 4. Dimensions for Vans, Modified Vans, Body on Chassis, and Small Buses (1980 Vehicles)

Dimensions	Vans	Modified Vans	Body on Chassis	Small Buses
<u>Overall (in inches)</u>				
Length	178 - 227	220 - 227	233 - 320	312 - 384
Width	80	80 - 94.5	80 - 96	96
Height	80 - 84	101 - 115*	93.5 - 117	99 - 114
<u>Interior (in inches)</u>				
Width	69 - 71	69 - 82	79 - 90	90 - 92
Headroom	52 - 54	64 - 74	63 - 78	76 - 78
GVW (pounds)	6,050 - 8,550	9,000	10,250 - 18,000	18,250 - 22,000
Wheelbase (inches)	110 - 138	127 - 138	125 - 180	168 - 252
Seating Capacity	5 - 15	9 - 16	12 - 30	23 - 35

*Higher value generally indicates the addition of air conditioning mounted on the roof.

Source for Vans, Modified Vans, and Body on Chassis: Reference 102.

A Typical Standard Van



STANDARD VAN. Standard vans have a typical seating capacity of from 5 to 15 passengers. Standard vans are available from automobile manufacturers and are part of their standard production line.

Vans offer several advantages. They are readily available for buying or leasing. Maintenance service and parts are not difficult to obtain. The initial capital cost is lower than that of other small transit vehicles, and they also offer greater maneuverability than do the larger vehicles.

The disadvantage of the van is that, because it is not designed for use in transit service, it is not durable as a transit vehicle. The expected life of a van in transit

A Typical Modified Van



Courtesy of Universal Coach Corporation

service is three years, depending on a number of factors (such as the number of miles driven annually). In addition, entry into a van is difficult for some passengers because of the high first step and the low roof. The low roof also inhibits movement within the van, particularly to and from seats in the rear of the vehicle. If a lift or ramp is stored in the vehicle, it often protrudes into the van, further limiting seating space and maneuvering room. In order to clear the roof upon entry and exit, both the wheelchair occupant using the lift and the attendant must bend over.

MODIFIED VAN. The seating capacity of modified vans is approximately 9 to 16 passengers. A modified van is a standard van which has undergone some structural changes, usually made to increase its size and particularly its height. This is often accomplished by raising the roof (adding a bubble top). Other body changes include a widened door, and reinforced and insulated walls and roof. Chassis modifications can include an extended or widened wheelbase, heavy-duty brakes, and an improved suspension. Modifications to increase the safety and comfort of passengers include handholds for support, protective padding on hard surfaces, lower-rise steps at the entrance, roof ventilation for warm weather climates, and well-lighted interiors (102).

Modifications are not usually made by the original manufacturer. A modifier acquires the van and modifies it according to his agreement with the buyer. A modified van offers greater accessibility, less restricted interior movement, and more comfort than does a standard van.

However, care must be taken when raising the roof so that the structural integrity of the van is maintained (102). Some system operators claim that a raised roof makes the vehicle less stable (especially on open, windy roads), and that leaks often develop at the attachment line. Others say that the modifications add weight to the vehicle and reduce fuel mileage.

A Typical Body on Chassis



Courtesy of Coach and Equipment Sales Corporation

BODY ON CHASSIS. A body on chassis seats from 12 to 28 passengers and is typically composed of a light truck chassis underneath a special body. A supplier of a body on chassis will purchase a chassis produced by a company such as Chevrolet, Dodge, Ford, GMC, or International Harvester, and then manufacture the body. The body part is typically constructed around a steel frame and then attached to the chassis (Figure 5). This construction is similar to that of school buses.

Body-on-chassis vehicles offer certain advantages over vans. For example, they tend to be more durable than vans, having an expected life of five years, depending on a number of factors. Another advantage is that some body on chassis have dual rear wheels, making them more stable than vans and safer in accidents. They also offer more interior space, which is often necessary for stored

Figure 5. Typical Construction of a Body on Chassis

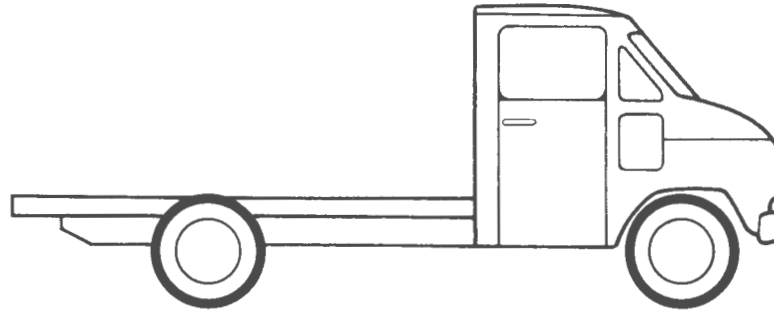

1 Chassis is purchased by the body builder.

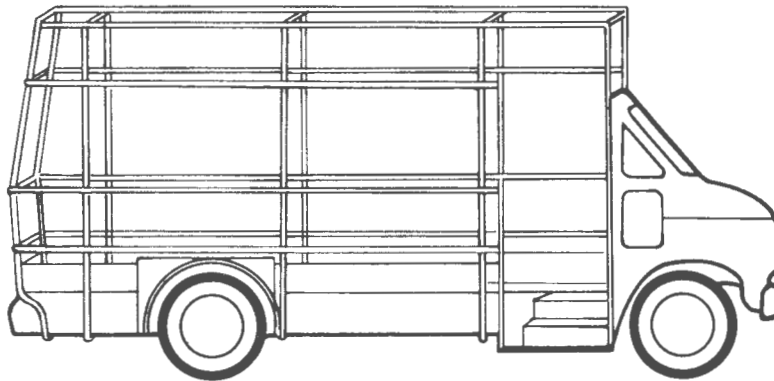

2 A framework is built for the body.

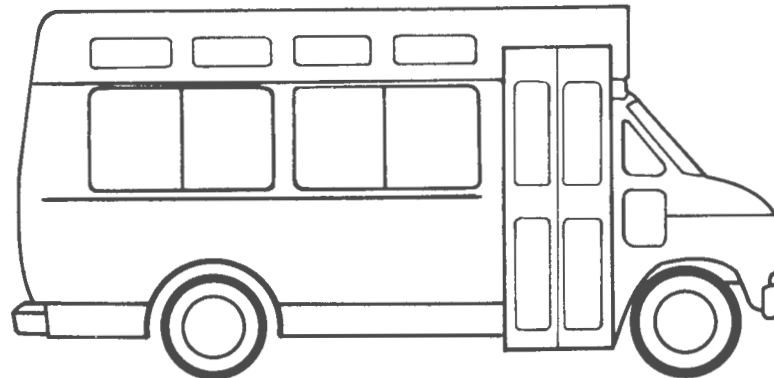

3 The body is finished and the vehicle is complete.

A Typical Small Bus



Courtesy of Hausman Bus Sales

lift equipment and for wheelchair stations. Some body on chassis have transit-type folding doors and low steps for ease of entry. Another advantage is the larger fuel tank capacities of body on chassis, which can be especially helpful when fueling stops are infrequent.

However, body on chassis are not built on a durable transit chassis. Some operators comment that body on chassis have stiff suspensions which produce a bumpy ride. The process of adding a body to a chassis results in special problems, such as the body being insecurely attached to the chassis, inaccessibility of chassis components for repair and inspection, damage of electrical components during body assembly, etc.

SMALL BUS. A small bus seats from 23 to 35 passengers and has both a body and a chassis which are designed specifically for transit service. One supplier manufactures the whole bus. Many of the components of a small bus are the same as those in standard transit vehicles (e.g., the engine, transmission, and axles). All of the small buses surveyed have diesel engines.

One of the major advantages of the small bus is its durability; for example, one of the small buses surveyed is expected to last from 10 to 15 years (120). The small bus offers the greatest amount of interior vehicle space, but is less maneuverable than the smaller vehicles. It also has a much higher purchase price. Another disadvantage is that the small buses which exist now have not been in operation for more than a few years; thus, little data is available on their performance.

OTHER VEHICLES. It should be pointed out that there are other vehicles which are currently in service and available for purchase, and others yet which are still under development. These are discussed only briefly in this report, because adequate information is available elsewhere.

1. Standard School Buses (24)

Standard school buses, which seat from 22 to 24 passengers, are a viable option; large fleets of these vehicles exist in many communities, including rural communities. This indicates that maintenance is available. By using an existing fleet, large financial investments for vehicles can be avoided while local interest in transit is tested (46). Leasing school buses is generally the cheapest method of obtaining vehicles.

However, there are disadvantages. Adults, especially elderly and handicapped people (who would probably be the prime users of such vehicles), are not comfortable in school buses, which are designed for children from 4 to 18 years of age. This is because of the high entrance steps, the relatively little space between the seats and the aisle, and the stiffness of the seats and suspension, all of which make for an uncomfortable and bumpy ride. Also, since school buses are not

designed for regular transit use, such use may decrease the life of the buses. School buses have large turning radii and are not as maneuverable as smaller vehicles. If a system wants to use only vehicles currently belonging to a school fleet, the number of vehicles available during peak travel times is limited. It is also important to note that there are regulations at all levels of government regarding the use of school buses for passengers other than pupils.

2. Station Wagons

Station wagons seat from 4 to 10 passengers. They can be readily bought or leased, and parts and service are also readily available. The capital investment is lower than that for the larger passenger-carrying vehicles, and resale is relatively easy (a factor not to be overlooked, as project needs may change over time) (46). Case studies have found that automobiles and station wagons are used principally in those rural areas in which volunteer drivers are part of a project, or as backup vehicles for systems in which van-size vehicles are not in regular service (46). Station wagons provide a smooth ride and are highly maneuverable. They are not, however, durable in transit service, nor do they allow passengers much movement within the vehicle.

3. Electric Vehicles (31,32,50,57)

Electric vehicles (EV's) have conventional chassis in which internal combustion engines have been replaced with electric motors and propulsion systems powered by acid lead batteries. EV's at their present state of development are considered by many to be mere novelties. In addition, there are few manufacturers producing such vehicles with a capacity of over four passengers. The primary attraction of electric vehicles is that they neither use petroleum fuels nor emit pollutants. They are also very quiet.

One of their disadvantages is that they cannot travel far without battery recharges; research is being done, however, to combat this problem. High speed travel drains batteries faster and further reduces the time between recharges. Other disadvantages are related to the relatively recent use of EV's. For example, there are few service and repair facilities, and both drivers and mechanics need special training.

4. Paratransit Vehicle Prototype

The Office of Bus and Paratransit Technology within UMTA has established a program to design small, accessible transit vehicles. These vehicles, which carry a driver and up to six passengers, are intended for those services which do not require the seating capacity of vans or the larger vehicles. The prototype program may include an in-service demonstration of a number of vehicles.

Two Types of Paratransit Vehicle

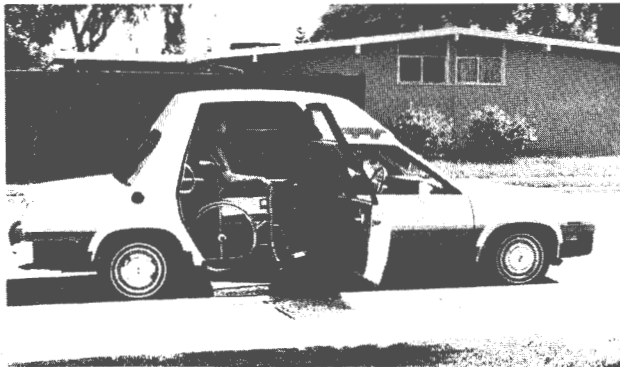

DIMENSIONS.

1. Wheelbase and Exterior Length

The longer the wheelbase, the larger the turning radius. If the body of the vehicle is much longer than the wheelbase (has, in other words, a large overhang), the vehicle is less maneuverable and less stable.

2. Exterior Width

Some states regulate the width of buses. As shown in Figure 6, most states limit the width of buses to 102 inches. This regulation poses no problem for small transit vehicles since the widest small vehicles, the small buses, are only 96 inches wide.

Figure 6. Bus Width Limitations

96 Inches	102 Inches		108 Inches
ALABAMA	CALIFORNIA=* +	NEBRASKA	HAWAII
ALASKA* +	COLORADO +	NEW HAMPSHIRE +	
ARIZONA	CONNECTICUT	NEW MEXICO* +	
ARKANSAS	DIST. OF COLUMBIA*	NEW YORK*	
DELAWARE	GEORGIA =	NORTH CAROLINA	
FLORIDA	IDAHO	NORTH DAKOTA*	
NEVADA*	ILLINOIS* +	OHIO*	
NEW JERSEY	INDIANA* =	OKLAHOMA +	
SOUTH DAKOTA	IOWA	OREGON* =	
UTAH	KANSAS =	PENNSYLVANIA	
WASHINGTON +	KENTUCKY =	RHODE ISLAND	
	LOUISIANA	SOUTH CAROLINA =	
	MAINE +	TENNESSEE*	
	MARYLAND* =	TEXAS =	
	MASSACHUSETTS* =	VERMONT +	
	MICHIGAN =	VIRGINIA* +	
	MINNESOTA*	WEST VIRGINIA*	
	MISSISSIPPI	WISCONSIN*	
	MISSOURI +	WYOMING	
	MONTANA		

* For comments and exceptions see Reference 68.

+ Not including mirrors and accessories attached thereto.

= Urban buses only.

Source: Reference 68.

Wheelchair Passenger Bending Her Head to Enter Van



Source: *Passenger Assistance Techniques Slide Show*

3. Interior Height and Aisle Width

A 1977 survey of state governments who bought vehicles under the Federal Section 16(b)(2) program (Federal programs are discussed in Chapter IV), reported that height of from 72 to 74 inches is preferred, but that interior heights of over 65 inches make the vehicle more difficult to handle in headwinds. This handling problem most often occurs with modified vans which have altered centers of gravity due to roof modifications. Although headroom is increased in modified vans by raising the roof, it is also increased by lowering the floor. The increased headroom may or may not be necessary over both the aisle and seats, depending on the ability of passengers to slide into seats.

The aisle width should accommodate passengers and the assisting devices passengers may use, such as crutches, walkers, or wheelchairs. (See Figure 7 for general guidelines.) Wheelchairs may pose problems if wheelchair passengers must turn around within the vehicle. The seating arrangement can often be arranged to allow for this.

If passengers are expected to stand while in transit, as in fixed-route service, this should be taken into consideration when determining aisle width (84).

4. Door Height and Width

A door high enough to allow passengers to walk upright into the vehicle greatly increases accessibility, and can thus decrease the time it takes passengers to enter and leave a vehicle (thus reducing time requirements at stops). On standard vans the door height does not allow this, but on modified vans the door height is increased by either raising the roof or lowering the floor. The body design of the larger vehicles often takes this need into account. Passengers who find it difficult to stoop, or who use assisting devices, find they especially need a large door space.

A door which accommodates a wheelchair lift or ramp can be a problem on a standard van. To clear the top of the doorway, either the wheelchair passenger must bend his head or the attendant must stoop down and tip the wheelchair before wheeling it in.

STEPS. Entrance steps prevent 29 percent of the handicapped population from using a transportation vehicle (1). Some of these people can be helped by having a lower first step. A first step of from 7 to 13 inches from the ground is recommended by many sources. One report, summarizing various studies on step design, sees no advantage in having a step lower than seven inches; indeed, a step as low as four inches may cause passengers to trip (84). However, inclined handrails in the stairwell can assist passengers to negotiate steps. Retractable steps and stools are also used to provide a lower step. When stoops are used in this

Figure 7. Aisle Space Requirements for Various Users

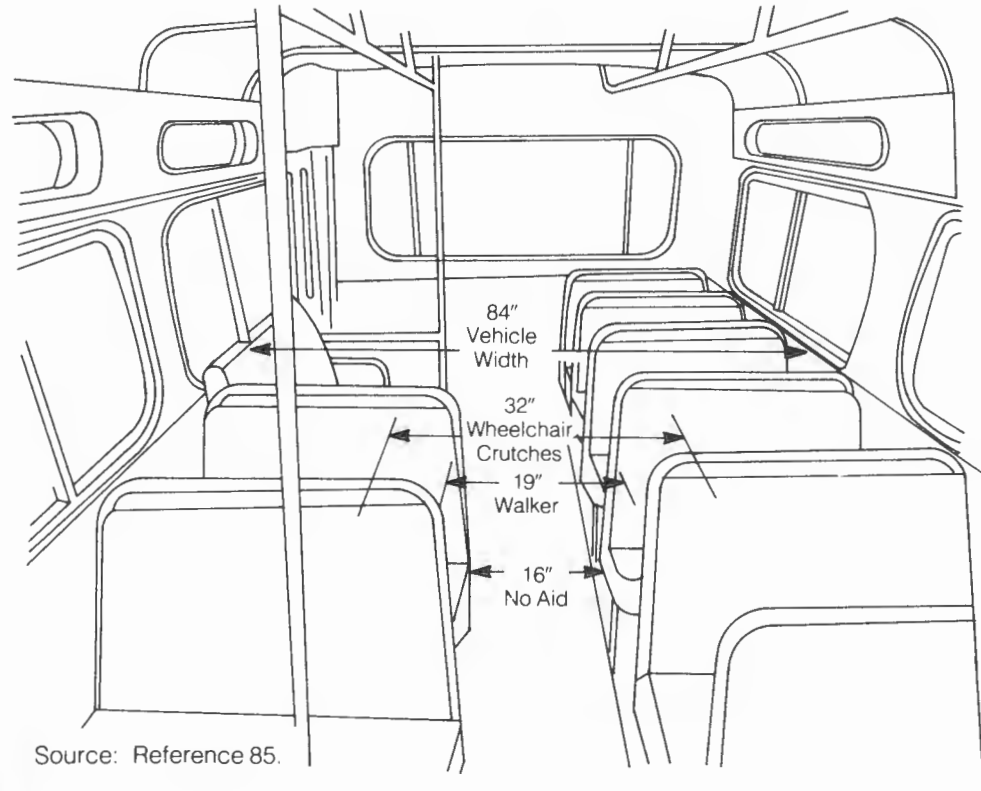

Source: Reference 85.

Stool and Retractable Step



Source: *Passenger Assistance Techniques Slide Show*

way, however, additional time is required for the driver to place and store the stool. In addition, stools are not always stable.

One disadvantage of lowered steps is that they are susceptible to damage from raised objects on the road or from the vehicle stopping too close to a curb (46). Also, steps which can be totally enclosed by the entrance door are protected from ice, snow, mud, and rain, and are thus safer to use.

SEATS. The kind of seats and their layout will depend on the length of the trip and the smoothness of the ride.

Seats vary in their dimensions, construction material, and the method of attachment to the vehicle.

The *seat dimensions* should take into consideration the difficulty some individuals have getting into and out of the seat. For example, seats should have a restricted incline (84).

Padding may be desirable for long trips or for passengers who need the extra comfort.

The *method of attachment* chosen should take into account various considerations, such as the need to remove seats temporarily, and the ease of cleaning (84).

The seating layout is determined by the seating capacity and the positioning of the seats. Some typical seating arrangements are shown in Figures 8 and 9.

Suppliers may specify the seating capacity of the vehicle, but some operators have found the stated capacity to be overestimated for the level of comfort they desire.

There are several ways to position seats; forward, sideways, and diagonally. In general, side-facing seats are more accessible from the aisle. However, the motion of the vehicle can cause passengers to sway and even fall out of the seat during a sudden stop. A vehicle with a standard transmission may jerk during the shifting of gears and can be particularly uncomfortable for side-seated passengers on hilly terrain (25). Putting armrests on side seats can provide some support. An alternative to forward- or side-facing seats is seats at a 45 degree angle to the front of the vehicle. This arrangement increases seating room and leg room, but decreases the number of seats.

The placement of wheelchairs in a vehicle requires some adjustments. Seats can be installed so that their removal is possible to allow for securement of wheelchairs. In general, one wheelchair station is equal to two standard seats. Some vehicles have seats bolted into a track on the floor and some operators find this a convenient way to rearrange and remove seats. Some seats can be folded up so that wheelchairs can back up against them.

The positioning of a wheelchair passenger is important for safety and comfort since handicapped passengers cannot always control body movements. A secured wheelchair facing the rear of the vehicle with a padded support behind the chair and the occupant's head is the safest position (40), but it does not allow for flexible seating arrangements, it requires more space, and it prevents passengers from seeing where they are going. (See the discussion on wheelchair securements below.)

Due to the limited interior space of vans and some body on chassis, transporting more than one wheelchair passenger at a time may require that the first wheelchair to enter the vehicle be the last to leave.

Figure 8. Typical Seating Arrangements for Standard Vans and Modified Vans

STANDARD VANS

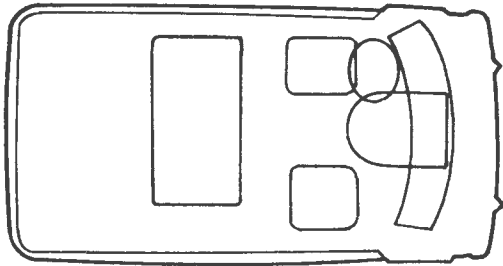

5 passengers

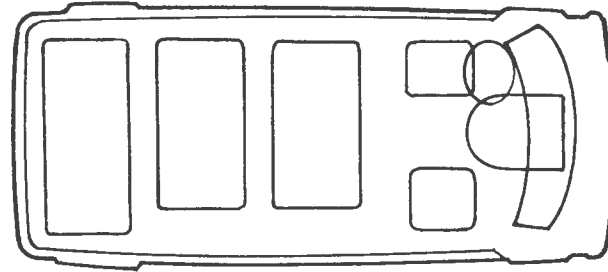

12 passengers

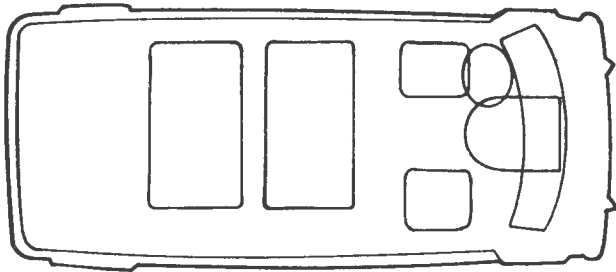

8 passengers

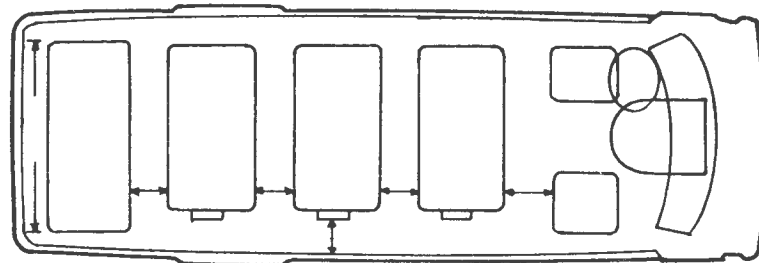

15 passengers

Source: Reference 102.

MODIFIED VANS

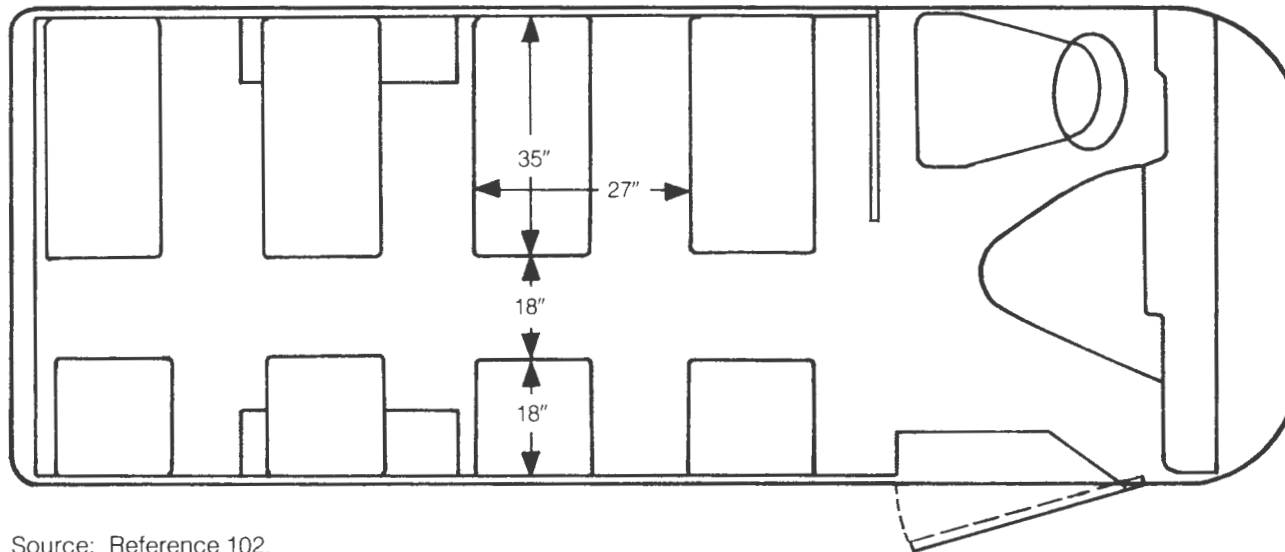
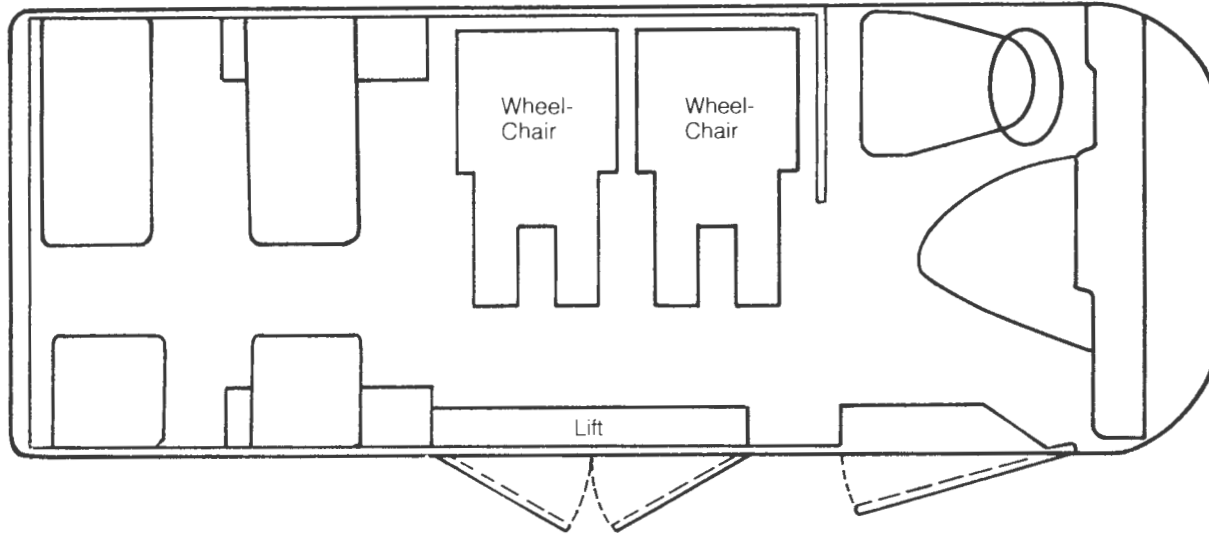

Source: Reference 102.

Figure 9. Typical Seating Arrangements for a 12-Passenger Body on Chassis, 20-Passenger Body on Chassis, and Small Bus.

12-PASSENGER BODY ON CHASSIS

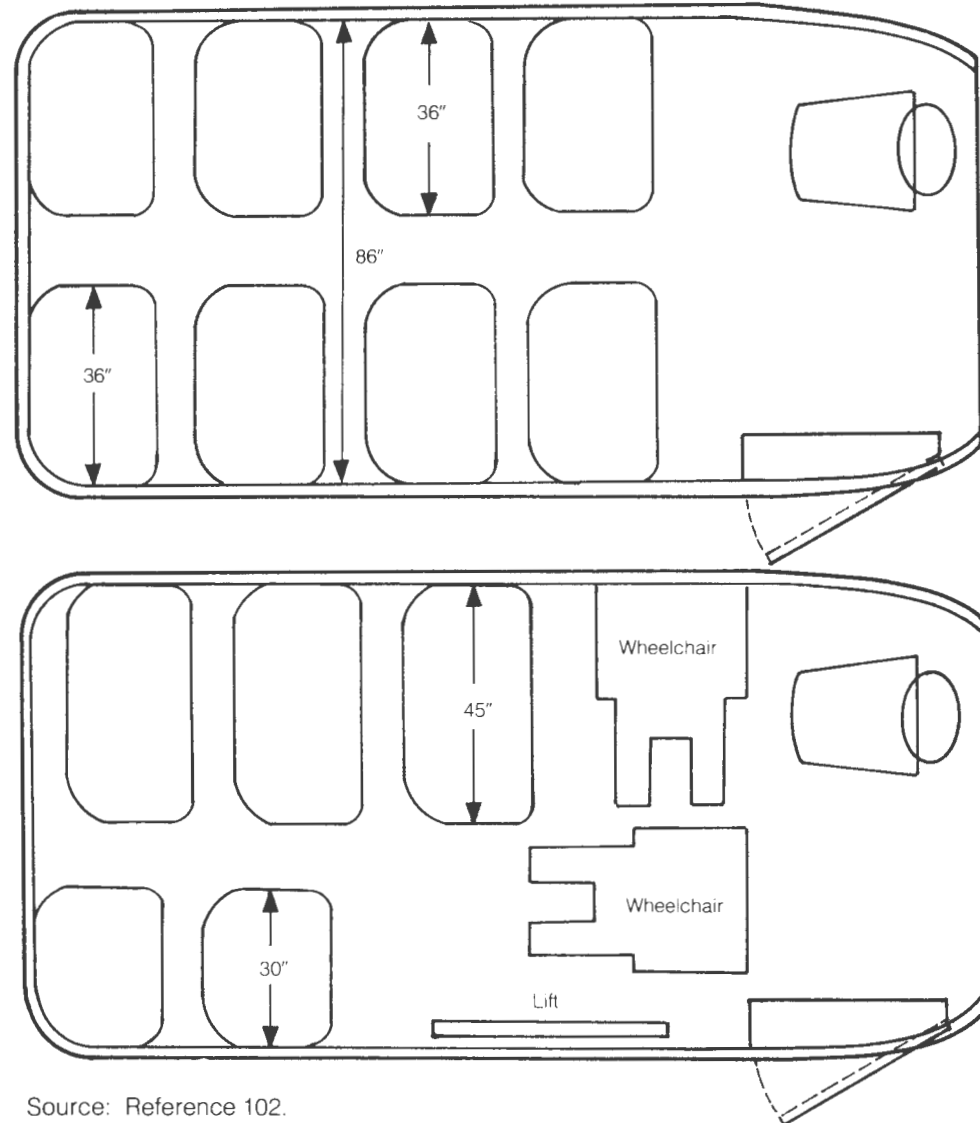

Source: Reference 102.

20-PASSENGER BODY ON CHASSIS

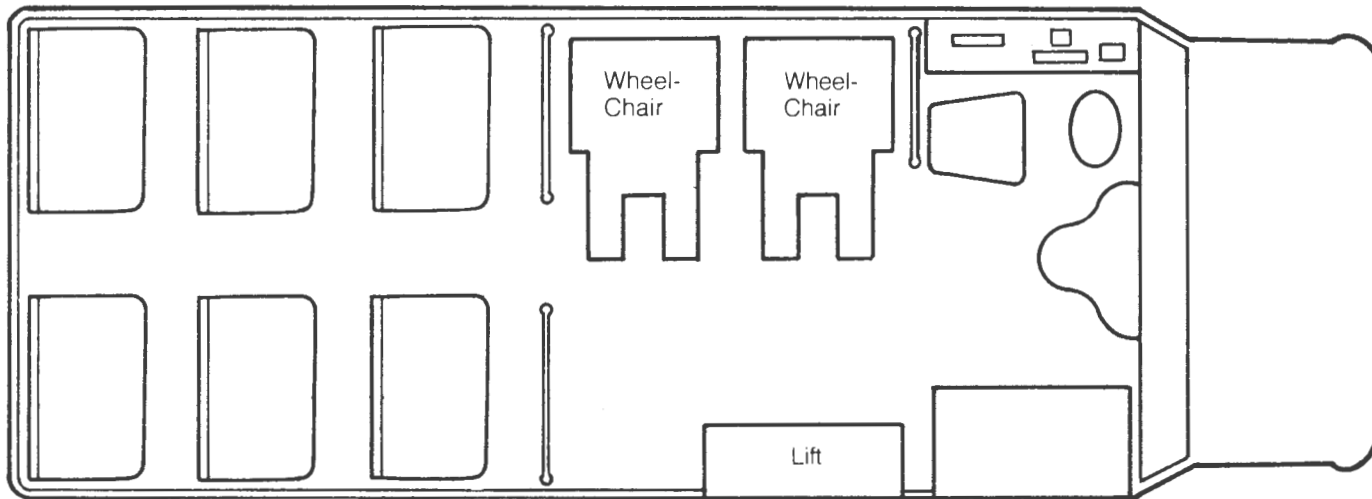
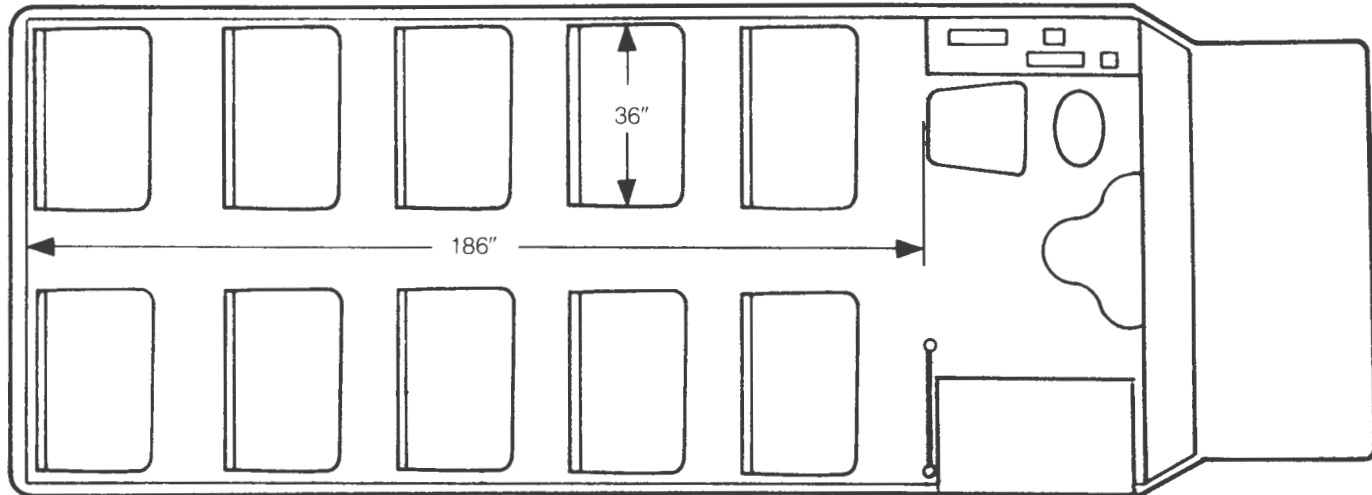

Source: Reference 102.

SMALL BUS

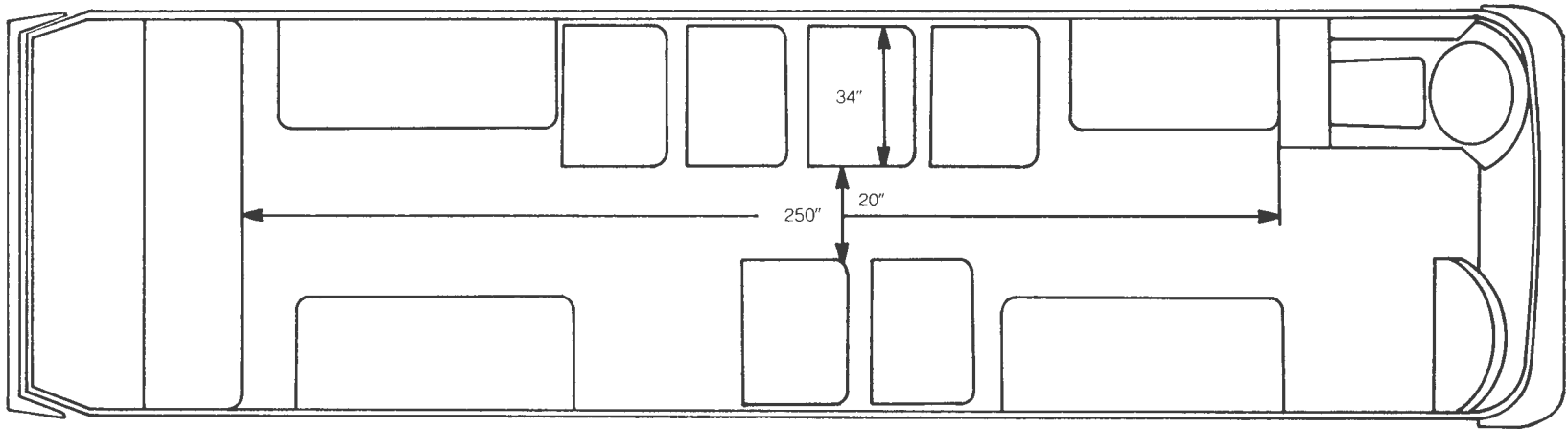
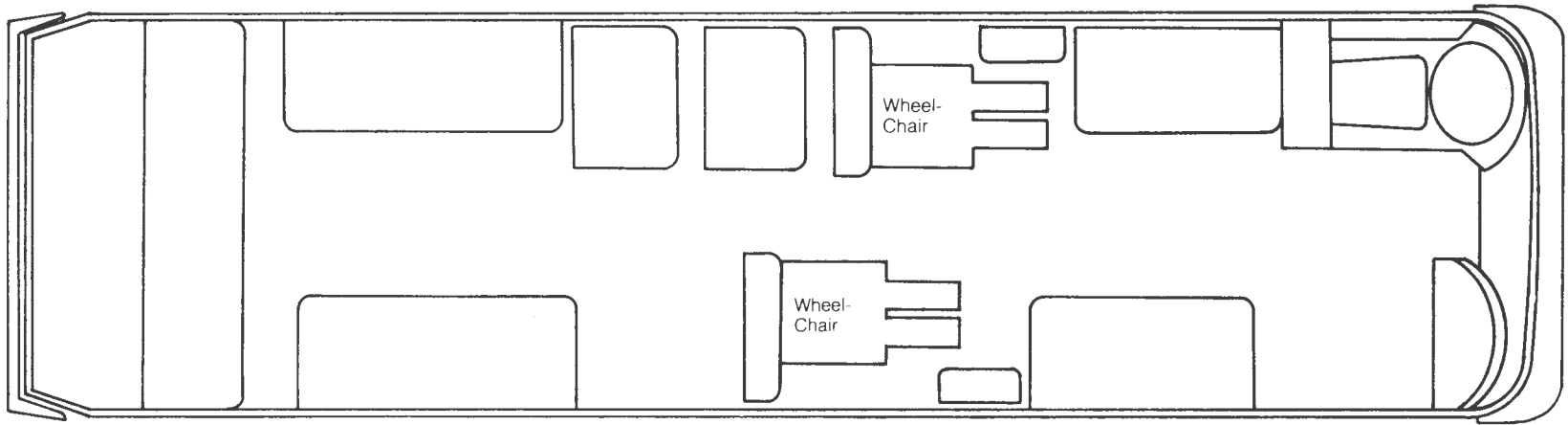

Stanchions and Support Rails



Courtesy of Coach and Equipment Sales Corporation

Skid Resistant Rubber Floor Covering

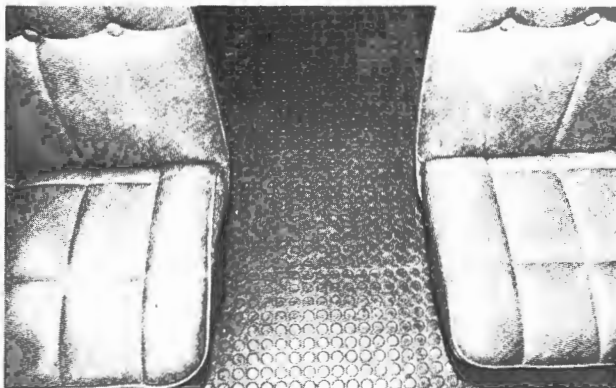

Courtesy of Universal Coach Corporation

SUPPORT RAILS. These include stanchions (upright posts), overhead rails, and seatback rails. Overhead rails may be difficult for some to reach, and provide little stability during motion (84). Experience indicates that the optimal rail is from waist to shoulder height, but this is not feasible, however, with high density seating. A viable setup is one using a hand-over-hand reach by alternating stanchions and seatback rails (84).

FLOOR COVERING AND SEAT MATERIALS (85). Vehicle floors are covered not just for looks, but for many functional reasons as well. Carpeting, for instance, absorbs interior noise and provides a soft surface to walk on.

A skid-resistant rubber mat cemented to the floor is an alternative to carpeting. It is less troublesome to maintain, and is recommended over carpeting when some type of textured or webbed material is specified to allow adequate protection in directions both parallel to and perpendicular to a passenger's line of motion.

DOORS. There are three major types of doors: bifold doors, sliding doors, and conventional, automobile swing-out doors. Large vehicles generally use bifold doors. Most vans are built with sliding doors; operators have complained that these doors are not durable in a transit service where the doors are constantly being opened and shut (49). Swing-out doors are easier to open than sliding doors; they're also lighter and less expensive (93). Some operators have indicated that swing-out doors on the wheelchair entry are not provided with adequate latches to keep the doors open while the lift is in operation. Unlike other types of doors, swing-out doors require extra clearance for opening.

In general, depending on the placement of the farebox, the door which accommodates a wheelchair lift or ramp is best placed to the rear of the front wheels. This allows direct access to the passenger area and gives the wheelchair user more space in which to maneuver upon entering the vehicle.

Emergency exit doors are generally in the rear of a vehicle. This may prevent the placement of a seat along the rear of the vehicle.

The placement of locks and warning buzzers on all doors and safety bumper cushions over each doorway is recommended (49).

CHASSIS. Some of the chassis components for vans and body on chassis are shown in Figure 10.

1. Engine

The gasoline and the diesel engines are the two major types of engines in transit vehicles. Within these types there are different sizes and configurations. The

Figure 10. Basic Components of a Van Chassis

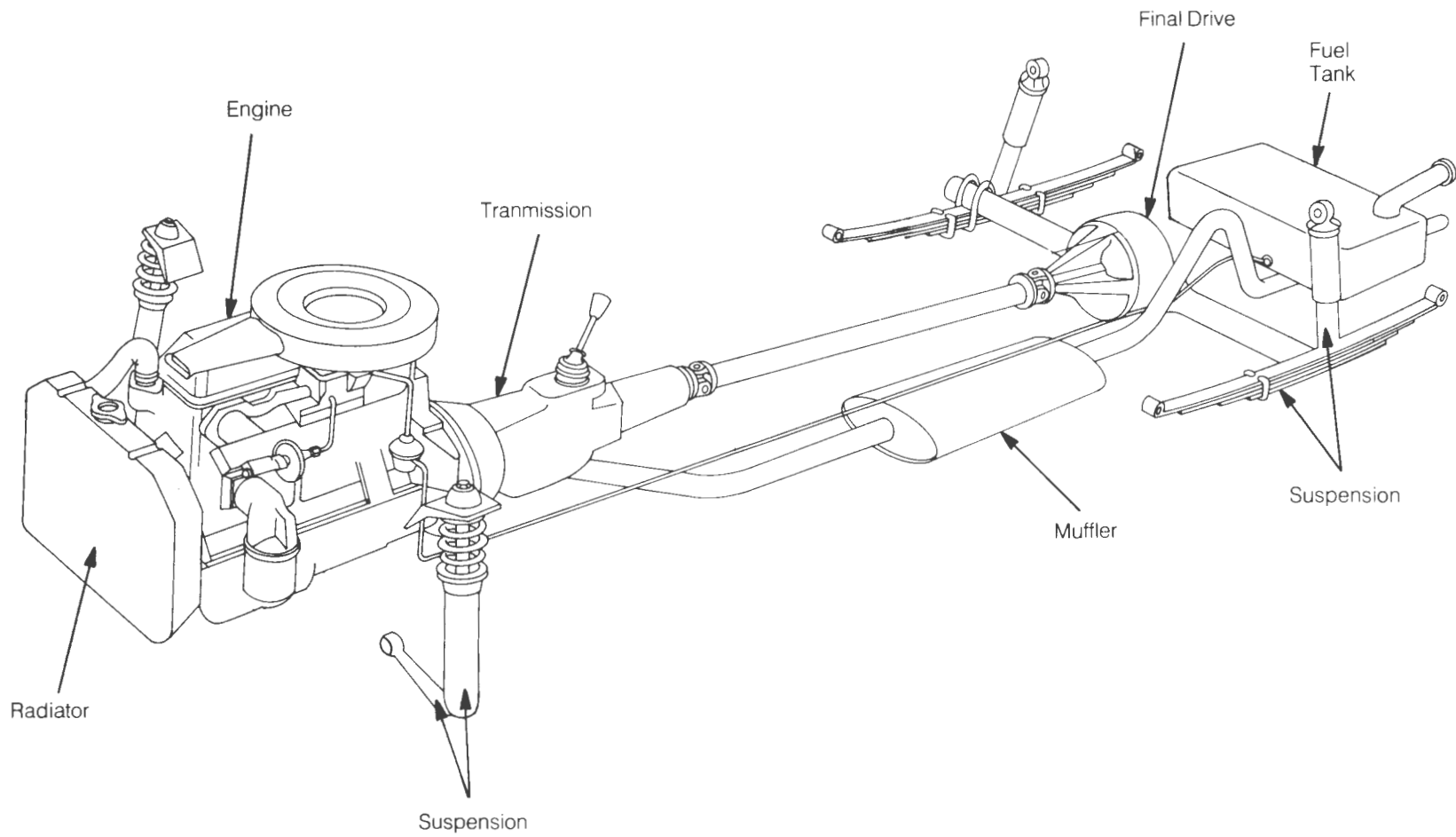

exact engine chosen depends on the weight of the vehicle and on the nature of the service for which it will be used. Manufacturers and experienced operators can provide advice in this matter.

Most buses are diesel. The major difference between gas and diesel engines is that gas engines ignite electrically, whereas diesel engines ignite by friction and compression. Diesels do not have the electrical components (such as points, plugs, wires, and condensers) that gasoline engines require, since diesels do not need carburation (the mixing of air and fuel).

The advantages of diesels are:

- Cheaper fuel
- Better fuel mileage — a savings in fuel used of from 20 to 40 percent (64)
- Longer engine life, longer warranties; engine failure is often the major cause of vehicle retirement
- Better reliability and fewer maintenance costs.

The disadvantages of diesels are:

- Higher initial costs
- Difficulty starting in cold weather
- Higher noise levels
- The need for different tools and for mechanics familiar with diesels.

These disadvantages can often be ameliorated. The purchase price may be offset by the lowered operating cost. Heated, indoor storage or special equipment can help the engine start in cold weather. Engine compartments can be insulated to keep noise from the passenger compartment. For example, the integrated dial-a-ride and fixed-route system which operated in Ann Arbor, Michigan insulated the engine with a 1-inch thick fiberglass material to minimize the escape not only of noise, but also of heat and fumes (71).

Since fuel costs continue to rise, another important aspect of engine selection is its effect on fuel efficiency. (Fuel efficiency is also affected by such factors as trip length, weather, condition of vehicle, road conditions, speed, driving habits of operator, weight of the vehicle, and vehicle accessories.) (104)

2. Transmission

It is important to have the proper transmission for the engine model and the proper gear ratio for the speed at which the vehicle will commonly be traveling. This provides a safer trip and keeps the wear on the drive train low (93, 46).

A survey of modified vans and body on chassis used in specialized transportation found that transmissions last between 60,000 and 80,000 miles before requiring replacement (102).

3. Suspension

As with all the components, heavy-duty shock absorbers and the heaviest possible suspension are needed to carry the heavy bodies on the chassis and to withstand the rigors of transit service. The heavy bodies can cause front ends and tires to wear quickly. A stiff suspension can produce an uncomfortable and bumpy ride. A smooth ride is facilitated by heavy-duty shock absorbers, and by high-capacity springs and axles. A high-capacity suspension is especially necessary with poorly paved roads and constant stop-and-start driving.

4. Brakes

One of the first vehicle difficulties an operator cites with vans and body on chassis is brake failure. Even with heavy-duty brakes, brake pads and shoes wear quickly and have to be replaced. For this reason, front-wheel disc brakes and rear-wheel drum brakes are recommended (49, 102). This lengthens the brake life and improves the stopping performance. Rear disc brakes are not considered a necessity, since front brakes absorb most of the force in stopping (102).

5. Electrical System

Optional equipment such as air conditioners, extra lighting, radio communication, ancillary heaters, and wheelchair lifts place greater demands on the electrical system. For this reason, heavy-duty alternators, of from 90 to 120 amps, are recommended for vehicles other than small buses (102). Small buses use alternators ranging from 140 to 190 amps.

Heavy-duty batteries are also advised for all vehicles. Operators have had trouble with the ability of heating and cooling units to keep a consistent temperature throughout the vehicle.

A few comments concerning electrical wiring are in order. In some cases, in the process of modifying vans or placing bodies on chassis, electrical wires have been interfered with, resulting in electrical difficulties. Uniformity in the routing and color coding of cables facilitates maintenance. Lastly, precautions can be taken to protect electrical cables from mud, snow, and ice.

AIDS FOR THE VISUALLY OR HEARING IMPAIRED.

1. Colors

Colors chosen for the vehicle exterior may reflect personal taste, but it should be kept in mind that distinctive colors make a vehicle more visible to visually-impaired passengers. Furthermore, when colors in the interior are utilized to create a contrast between the seats and the floor (for example, dark seats and a light floor), visually-impaired passengers are able to move more easily within the vehicle (44). Some systems paint the steps or step edges yellow or orange in order to make them easier to see (60, 78).

Platform Lift



Courtesy of Dial-A-Bat, Brockton, Mass.

Step Lift



Courtesy of Vapor Corporation

2. Lighting

Lighting in the vehicle and stairwells facilitates movement (44, 46).

3. Informational Devices

Special chimes or PA systems can announce a vehicle's arrival to visually-impaired persons. Allowing a person to sit close to the driver permits the driver to communicate more easily with the passenger (44).

AIDS FOR THE NONAMBULATORY OR SEMI-AMBULATORY.

1. Boarding Devices

There are two basic devices to help passengers who can not use steps. Although a discussion of both of these follows, it should also be noted that emergency evacuation of the vehicle should also be taken into account when choosing a boarding device. Appendix B contains a list of lift and ramp manufacturers.

a) Lifts

There are two major types of lifts: electromechanical lifts, which use belts, chains, or cables to operate; and electrohydraulic lifts, which use cylinders of fluid (fluid pressure) to operate.

A lift permits access for a wheelchair user by first lowering a platform to ground level, allowing the user to wheel onto the platform, and then raising the platform to the same level as the vehicle floor so that the user can wheel into the vehicle. Some systems permit semi-ambulatory passengers to use a lift while they are standing. Vans, modified vans, and body on chassis generally store lifts vertically, inside or outside the vehicle alongside a door. However, lifts can also be stored on top of the vehicle. Small buses usually have lifts which serve as steps for ambulatory passengers and which unfold from the step configuration into a platform. These lifts are called active lifts or step lifts. (References 14, 15, 97, 99 contain discussions of active lifts in service.) Figure 11 lists safety guidelines recommended by many sources for use in lift purchase specifications or installation.

The *location of the lift* is important (102). Storing a lift on the outside of a vehicle affords more seating and maneuvering room inside the vehicle. Lifts stored outside the vehicle are usually attached to the rear door, because placement above the bumper is convenient, and because it is dangerous to have an unusual protrusion on the side of the vehicle. However, exposing the lift to wet weather or snow may necessitate that the lift be cleaned before each use, and may also increase the possibility that the lifting mechanism will freeze. In addition, a lift located outside of the vehicle is more easily damaged in a collision.

Figure 11. Recommended Safety Features for Use of Wheelchair Lifts

- PADDING OF HAZARDOUS PROTRUSIONS AND EXPOSED EDGES OF LIFT WHEN STOWED IN VEHICLE.
- PAD UPPER FRAME OF LIFT DOORWAY.
- ENCLOSURE OF EXPOSED PARTS AND MOVING PARTS.
- INTERLOCK SYSTEM ON VEHICLE BRAKE OR TRANSMISSION TO PREVENT VEHICLE MOVEMENT WHILE LIFT IS IN OPERATION.
- SHUT-OFF MECHANISM, WHICH STOPS LIFT OPERATION, ACTIVATED WHEN LIFT STRIKES AN OBSTRUCTION.
- IN CASE OF A POWER FAILURE, USE MANUAL OVERRIDE TO ALLOW LIFT OPERATION.
- MECHANISM TO ENSURE SLOW FREE FALL OF LIFT PLATFORM IN THE EVENT OF A POWER FAILURE.
- MINIMAL VIBRATION TO PERMIT USERS TO STAND AND RETAIN THEIR BALANCE; AND TO AVOID THE LOOSENING OF FASTENERS FOR JOINING PARTS.
- BACK AND SIDE PLATES ON PLATFORM TO KEEP WHEELCHAIR FROM ROLLING OFF.
- SLIP RESISTANT MATERIAL ON PLATFORM.
- AUDIO AND VISUAL SIGNALS TO ALERT PEOPLE WHEN LIFT IS IN OPERATION.

Source: References 15, 74, 85, 95, 97, 102, 118.

Protective Padding on a Lift Stored Inside a Vehicle



Courtesy of Braun Corporation

Rear-door lifts are preferred in areas where there are streets which are one way, or streets which have roadside ditches, tall grass, heavy snow, and/or narrow driveways.

Side-door-mounted lifts are more common in urban areas where curbside pickups are frequent. If a vehicle stops in the street rather than in a driveway, it is less dangerous for passengers to board from the sidewalk than from the street behind the vehicle. The risk of a passenger being struck by another vehicle is greater on the street.

The cost of acquiring and utilizing a lift is expensive. Figure 12 lists the price range of lifts. Vehicle operating costs are affected by lifts in a number of ways. Fuel costs may increase due to the added weight of the lift. Increased driver training and higher driver wages due to a driver's increased duties and responsibilities for passenger assistance may be necessary. In addition, maintenance costs may

Passenger Being Assisted up a Ramp



Source: *Passenger Assistance Techniques Slide Show*

Ramp in Storage Position



Courtesy of Handiramp, Inc.

Figure 12. Price Ranges for Ramps and Wheelchair Lifts (in Dollars)

Lifts	
Platform	1,300 - 3,000*
Step	10,000 - 25,000*
Ramps	
	400 - 700*

*Higher price includes installation costs.

increase, because of the need for additional training for mechanics, for a parts inventory, and possibly for special tools. Another impact that a lift may have on a service is that a revenue-producing service may find that the reduced seating and the increased time spent at some stops affects revenues.

b) Ramps

There are fewer commercially available ramps than there are lifts. Ramps are often designed and made by individual vehicle suppliers to fit into their own vehicles. Ramps cost less than lifts, are installed more easily, operate more simply, and require less maintenance. They are attached on top of or underneath the vehicle floor. They are stored in a folded vertical position inside the vehicle or horizontally underneath the floor.

Generally, ramps are operated manually. Although a ramp which rests on a curb rather than on the street can reduce the steepness of the incline, most wheelchair passengers must be assisted up and down the ramp, even if the ramp rests on the curb rather than on the street (and is therefore less steep). This requires some strength on the part of the assistant or driver and has caused back injuries in some cases (88, 95).

Passengers using walkers, canes, or crutches have difficulty walking on an incline (85). It is recommended that a boarding chair (a folding wheelchair) be used to help these passengers board.

Although both lift platforms and ramps can become slippery in wet weather, it is more of a problem with a ramp since the assistant may also slip.

2. Wheelchair Securements

Wheelchair securements, also called restraints or tiedowns, are devices located inside the vehicle and attached to the vehicle in order to hold a wheelchair and its occupant in place while the vehicle is moving, or during a sudden stop or

Two Types of Wheelchair Securements

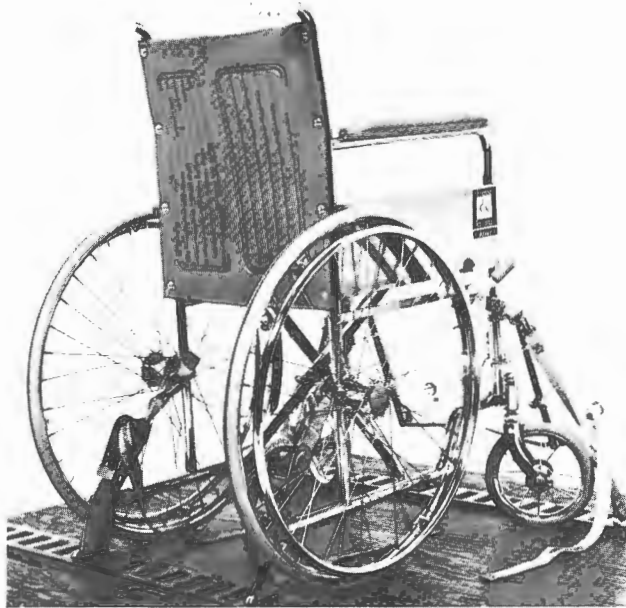

Courtesy of Aeroquip Corporation



Courtesy of American Seating Company

accident. This is done in order to protect both the wheelchair occupant and the other passengers. Devices currently used include belts, chains, metal brackets, and bars. Appendix B contains a list of securement manufacturers.

Most securements are operated manually. They are attached to the wall or floor of the vehicle or to the bottom of a foldable seat, and fasten onto the wheel or frame of the wheelchair. The design and location of the securement, and the disabilities and dexterity of the wheelchair user, affect the amount of driver assistance necessary to apply a securement device (96).

One problem operators have identified is that not all restraints can be secured to all wheelchairs. Often this is due to differences in the width of the tires or in the type of wheel. A recent study recommended that wheelchairs have a standard fixture which attaches to a standard securement (96).

Another concern of system operators and users is the need for valid testing of securements to ensure their reliability in a sudden stop. Some testing has been undertaken, but the results have shown that some restraints and some wheelchairs do not hold up in simulated crashes (90, 91, 96).

the need for backup vehicles

The number of vehicles an operator chooses to buy is integrally related to the service level to be provided, the size of vehicle chosen, and the operator's financial capabilities.

However, another important consideration in selecting the number of vehicles to acquire is the need for backup vehicles to be used in case vehicles are out of service due to breakdowns or routine servicing. Although very small systems may not be able to afford extra vehicles, situations in which vehicles are constantly out of service can severely affect the system's operation (12, 55).

The number of backup vehicles necessary is dependent upon the:

- Maintenance system's capability to acquire parts and perform maintenance on the base fleet quickly
- Possibility of routine care being done during non-operating hours (e.g., nights and weekends)
- Ability to limit breakdowns by routine preventive maintenance
- Feasibility of storage.

Some sources suggest formulas to calculate the number:

- For a fleet of less than 7 buses, have 1 spare; for a fleet of between 8 and 20

buses, have from 2 to 3 spares; for a fleet of greater than 20 buses, have 1 spare for each 10 vehicles (46).

- 10 percent of a regular fleet should be spare (13).
- From 25 to 30 percent of a small fleet should be spare (55).

In some cases, spares are vehicles which are at the end of their life, but which have undergone some repair (e.g., new engines) to permit their functioning on a part-time basis. However, some operators have found that frequent breakdowns of the regular fleet have required that spare vehicles operate full time.

uniformity of the fleet

Inexperience has demonstrated the importance of the uniformity of vehicles within a system fleet. Of course, not all systems have control over which vehicles they operate. Many new systems start a service with a variety of vehicles donated, leased, or bought from other agencies. Systems which are required by law to purchase a vehicle having the lowest bid may have to buy different vehicles each time a bid is awarded. In addition, the selection of vehicles offered on the market changes rapidly.

Nonetheless, a uniform fleet offers certain advantages. The primary advantage in uniformity is the ease of maintenance and repair. Mechanics need only be familiar with one type of vehicle, and it is simpler and cheaper to acquire and keep a parts inventory. It may also increase the efficiency of the maintenance operation, since as problems develop in one vehicle, steps can be taken to see that the problem does not recur with the other vehicles. The Integrated Transit Demonstration Project in Rochester, New York, used different types at one time in order to determine the best vehicle for future selection (55). As a result of a high number of vehicle breakdowns, the analysis of this experiment recommended that a system choose only one type of vehicle with a proven reliability record (77). In addition to maintenance, a fleet uniform in passenger capacity and seating arrangement makes scheduling and dispatching simpler because vehicles are interchangeable.

The main disadvantage of a uniform fleet is that its very uniformity limits its responsiveness to the varying demands placed upon it (35). An evaluation of the Section 147 Rural Public Transportation Demonstration Program revealed that there was a greater than anticipated need for one or two large vehicles for those systems which had a number of vans or small buses (12).

A Fleet of Vans used in an Employment Center's Vanpooling Program



III | PROCUREMENT

VEHICLES CAN BE procured in three ways: acquired from an existing fleet, leased, or purchased. Most of this discussion is concerned with purchasing since it can be the most complicated and time-consuming procurement process.

The last part of this chapter looks at funding sources, primarily governmental sources. Appendix C has a chart which lists and briefly describes many Federal programs.

acquisition from an existing stock

It is not always necessary to purchase a new vehicle. Vehicles can sometimes be acquired for use from an existing stock of vehicles, such as a school bus fleet, another transit service, or a social service agency. Many systems which intend to provide service for a number of organizations have the vehicles donated to them by the organizations for which they are providing service (51). These vehicles may also be leased by the agencies to the service provider, sometimes for a token fee of one dollar.

leasing

Leasing a vehicle is considered an option when:

1. Funds are limited in starting a new system, or when the system may not be implemented on a permanent basis.

Although leasing increases the operating costs of a project, capital costs are deferred (13). If funds do become available, or the system becomes permanent, the option of buying the vehicle at the end of the lease agreement may be considered.



Courtesy of the Regional Transportation Program, Portland, Maine

2. Start-up time is limited.

The application time for governmental funding can be lengthy. In addition, local, state, and Federal laws may require a system operator using public funds to acquire vehicles through a formal bid process, which may be time consuming.

In those cases, systems lease vehicles, because vehicles can be leased more quickly than they can be bought. Some systems simply lease vehicles while they're waiting to receive grant money.

3. The long-term service needs of a system are unknown.

Leasing allows a system to be flexible and to adapt to changes in vehicle needs.

4. Minimal administrative and accounting work is required.

A leasing agreement may be a full-service contract, with maintenance, insurance, and licensing provided by the lessor. The system provider thus avoids the administrative costs and time needed to provide and arrange for these services. Accounting and record keeping is simplified, because only lump-sum payments are necessary.

5. Leasing is cheaper than purchasing.

Leasing agreements are usually based on a set amount of mileage beyond which the lessee is charged for each additional mile traveled. (The example in Figure 13 demonstrates one process of cost comparison.) It is important to note that a short-term lease may be more expensive on a yearly basis than a long-term lease. For example, a 1-year lease may contain a charge for the majority of the depreciation of the vehicle, a longer lease would have the depreciation spread out over several years.

purchasing

A major advantage of purchasing is the greater variety of vehicles from which to choose. Vans and school buses are generally available through lessors, but other vehicles frequently are not, as they are usually built to order for a limited market. Most sources agree that the long-run costs of purchasing a vehicle are less than the costs of leasing. Purchasing also permits a system to build up equity.

If an operator relies on governmental funding assistance, a time-consuming application and approval process may have to be followed in order to purchase vehicles. Therefore, a considerable amount of time may pass before an operator can ask vehicle suppliers to offer prices for their vehicles (to begin the bid process). For example, the DOT funding programs require the applicant to follow a specified

Figure 13. Leasing Versus Purchasing — Sample Cost Comparison

In the sample case below, an operator wishes to acquire seven vehicles. Given specific conditions, calculations are made to determine whether leasing or purchasing vehicles is less costly. The calculations for the purchase option are somewhat complicated, so it may be desirable to have someone knowledgeable in accounting principles to assist individual operators in comparing costs.

Leasing

Conditions:

- 7 vehicles
- \$6,000 yearly cost per vehicle

Equation:

$$7 \text{ vehicles} \times \$6,000 = \$42,000 \text{ per year}$$

Purchasing

Conditions:

- 7 vehicles
- \$35,000 per vehicle
- 10-year life
- \$1,000 salvage value
- 10% finance charge

Equation: (without grant)

$$[\text{purchase price}] \times [7 \text{ vehicles}] [\text{capital recovery factor}^* (10\% \text{ for } 10 \text{ years})] \\ \text{minus} \\ [\text{salvage value}] \times [7 \text{ vehicles}] \times [\text{sinking fund factor}^* (10\% \text{ for } 10 \text{ years})] \\ \text{equals}$$

yearly cost.

The equation for our sample:

$$\$35,000 \times 7 \times 0.16275 - \$1,000 \times 7 \times 0.6275 = \$39,434.50 \text{ per year}$$

Equation: (with 80% capital grant)

$$[\text{cost per year without grant}] \times [20\%] = \text{yearly cost.}$$

Thus, for our sample:

$$\$39,434.50 \times 0.2 = \$7,535.50 \text{ per year.}$$

Source: Reference 9.

***SAMPLE INTEREST TABLE - 10%**

n	Single Payment		Uniform Series				n
	Compound Amount Factor F/P	Present Worth Factor P/F	Sinking Fund Factor A/F	Capital Recovery Factor A/P	Compound Amount Factor F/A	Present Worth Factor P/A	
1	1.1000	0.9091	1.00000	1.10000	1.000	0.909	1
2	1.2100	0.8264	0.47619	0.57619	2.100	1.736	2
3	1.3310	0.7513	0.30211	0.40211	3.310	2.487	3
4	1.4641	0.6830	0.21547	0.31547	4.641	3.170	4
5	1.6105	0.6209	0.16380	0.26380	6.105	3.791	5
6	1.7716	0.5645	0.12961	0.22961	7.716	4.355	6
7	1.9487	0.5132	0.10541	0.20541	9.487	4.868	7
8	2.1436	0.4665	0.08744	0.18744	11.436	5.335	8
9	2.3579	0.4241	0.07364	0.17364	13.579	5.759	9
10	2.5937	0.3855	0.06275	0.16275	15.937	6.144	10
11	2.8531	0.3505	0.05396	0.15396	18.531	6.495	11
12	3.1384	0.3186	0.04676	0.14676	21.384	6.814	12
13	3.4523	0.2897	0.04078	0.14078	24.523	7.103	13
14	3.7975	0.2633	0.03575	0.13575	27.975	7.367	14
15	4.1772	0.2394	0.03147	0.13147	31.772	7.606	15
16	4.5950	0.2176	0.02782	0.12782	35.950	7.824	16
17	5.0545	0.1978	0.02466	0.12466	40.545	8.022	17
18	5.5599	0.1799	0.02193	0.12193	45.599	8.201	18
19	6.1159	0.1635	0.01955	0.11955	51.159	8.365	19
20	6.7275	0.1486	0.01746	0.11746	57.275	8.514	20
21	7.4002	0.1351	0.01562	0.11562	64.002	8.649	21
22	8.1403	0.1228	0.01401	0.11401	71.403	8.772	22
23	8.9543	0.1117	0.01257	0.11257	79.543	8.883	23
24	9.8497	0.1015	0.01130	0.11130	88.497	8.985	24
25	10.8347	0.0923	0.01017	0.11017	98.347	9.077	25
26	11.9182	0.0839	0.00916	0.10916	109.182	9.161	26
27	13.1100	0.0763	0.00826	0.10826	121.100	9.237	27
28	14.4210	0.0693	0.00745	0.10745	134.210	9.307	28
29	15.8631	0.0630	0.00673	0.10673	148.631	9.370	29
30	17.4494	0.0573	0.00608	0.10608	164.494	9.427	30
31	19.1943	0.0521	0.00550	0.10550	181.943	9.479	31
32	21.1138	0.0474	0.00497	0.10497	201.138	9.526	32
33	23.2252	0.0431	0.00450	0.10450	222.252	9.569	33
34	25.5477	0.0391	0.00407	0.10407	245.477	9.609	34
35	28.1024	0.0356	0.00369	0.10369	271.024	9.644	35
40	45.2593	0.0221	0.00226	0.10226	442.593	9.779	40
45	72.8905	0.0137	0.00139	0.10139	718.905	9.863	45
50	117.3909	0.0085	0.00086	0.10086	1163.909	9.915	50
55	189.0591	0.0053	0.00053	0.10053	1880.591	9.947	55
60	304.4816	0.0033	0.00033	0.10033	3034.816	9.967	60
65	490.3707	0.0020	0.00020	0.10020	4893.707	9.980	65
70	789.7470	0.0013	0.00013	0.10013	7887.470	9.987	70
75	1271.8952	0.0008	0.00008	0.10008	12708.954	9.992	75
80	2048.4002	0.0005	0.00005	0.10005	20474.002	9.995	80
85	3298.9690	0.0003	0.00003	0.10003	32979.690	9.997	85
90	5313.0226	0.0002	0.00002	0.10002	53120.226	9.998	90
95	8556.6760	0.0001	0.00001	0.10001	85556.760	9.999	95
100	13780.6123	0.0001	0.00001	0.10001	137796.123	9.999	100



planning process. Applicants must have their capital request included in an area-wide plan approved by local and state agencies. Figures 14 and 15 show the typical procurement process for UMTA's Section 3, Section 5, and Section 16(b) (2) programs and for the Federal Highway Administration's (FHWA's) Section 18 program. Delays can occur at each step. For example, Section 3, Section 5, and Section 18 require that the grant recipients reach signed agreements with labor organizations before equipment is purchased. This sometimes causes extensive delays.

Some states which procure vehicles for grant recipients have had to delay the bid process until the local applicants send the state their local matching share of the Federal subsidy. The California Department of Transportation (Caltrans) has set up a revolving fund, with enabling state legislation, in order to have money available while recipients are in the process of collecting their matching share to send to the state. Each repayment to the fund is used as a future float until the next round of grant recipients send in their local share. This has enabled the state to complete the procurement process in from 6 to 8 months less time than the original 15 to 34 months it had been taking (17).

It is important to procure the vehicles as quickly as possible. If there is a significant delay, the local commitment to match state or Federal subsidies may wane, the prices of vehicles may increase, or the needs of the transportation service may change, requiring a different vehicle than was originally ordered.

BID PROCESS. Requesting bids is the most common procedure for procuring a vehicle, one reason being that it is required by public funding sources. A bid is basically a statement of which vehicle, and with what features, a supplier will sell to a buyer at which price. If the vehicle the buyer wants is specified to bidders, a comparison of bids allows the buyer the opportunity to purchase the best buy.

Generally, governmental funding sources require a formal advertisement for bids and a fair and open competitive process of receiving and analyzing bids. There are three common methods of advertising for bids: invitations can be mailed directly to suppliers, they may be printed in newspapers, or they may be printed in trade journals. (See Figure 16.) In addition, government regulations may require specific clauses and provisions in the advertisement, and in the contract documents between the buyer and seller.

The Federal government outlines its regulations concerning the procurement and selection of equipment, subsidized in whole or in part by Federal funds, in the following Office of Management and Budget Circulars:

No. A-102 — Uniform Administaring Requirements for Grants-in-Aid to State and Local Governments

Figure 14. Vehicle Procurement Flow Chart (Urbanized Area Grant Programs)

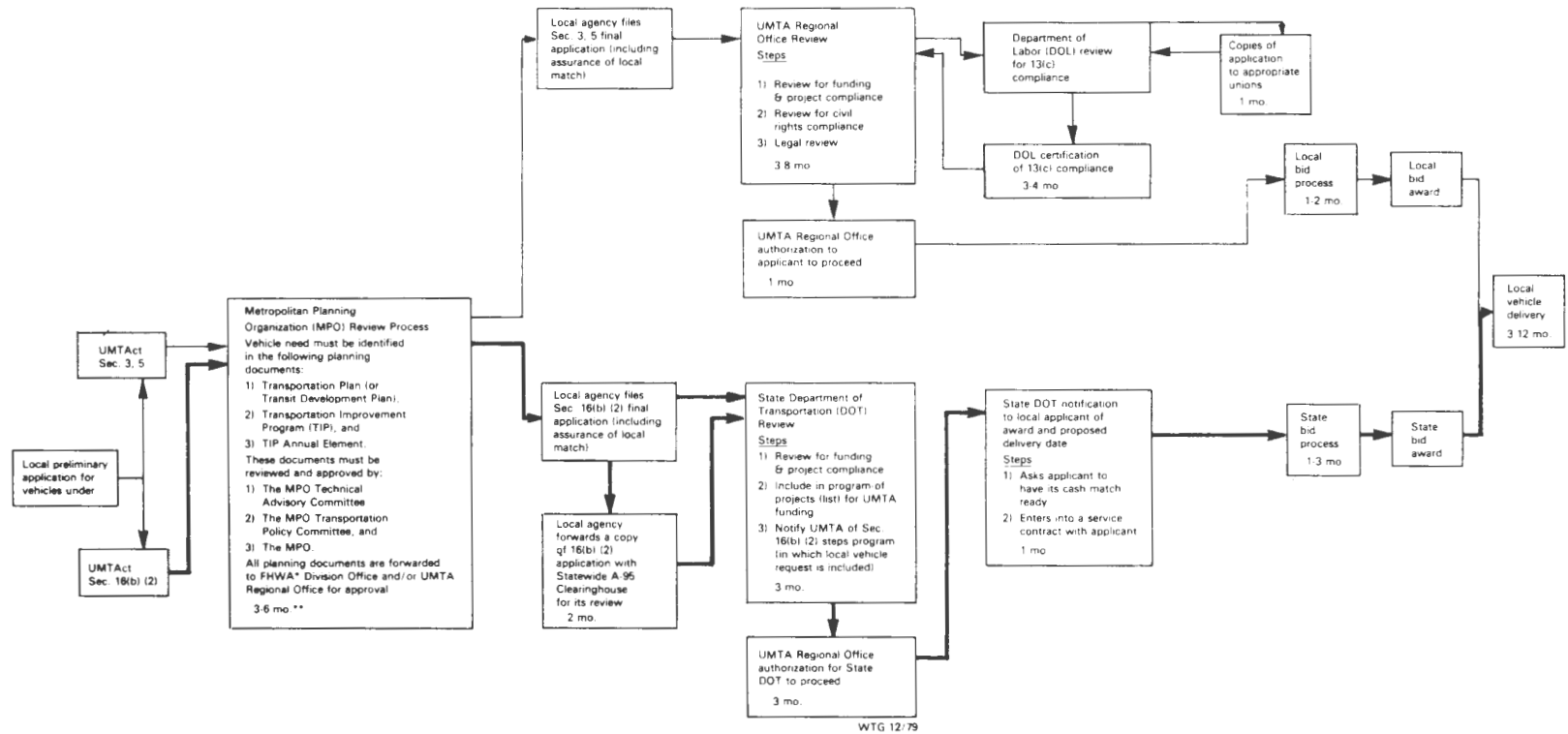

• FHWA = Federal Highway Administration

•• This represents the approximate (minimum and maximum when two numbers are given) time frame in months for completing a step.
 For Sec. 3 and 5 the time frame from preliminary application to vehicle delivery is 11-29 months. For Sec. 16(b) (2) the time frame from preliminary application to vehicle delivery is 14-28 months. The maximum times will be required as vehicles requested are customized to meet special needs.

Figure 15. Vehicle Procurement Flow Chart (Nonurbanized Area Grant Programs)

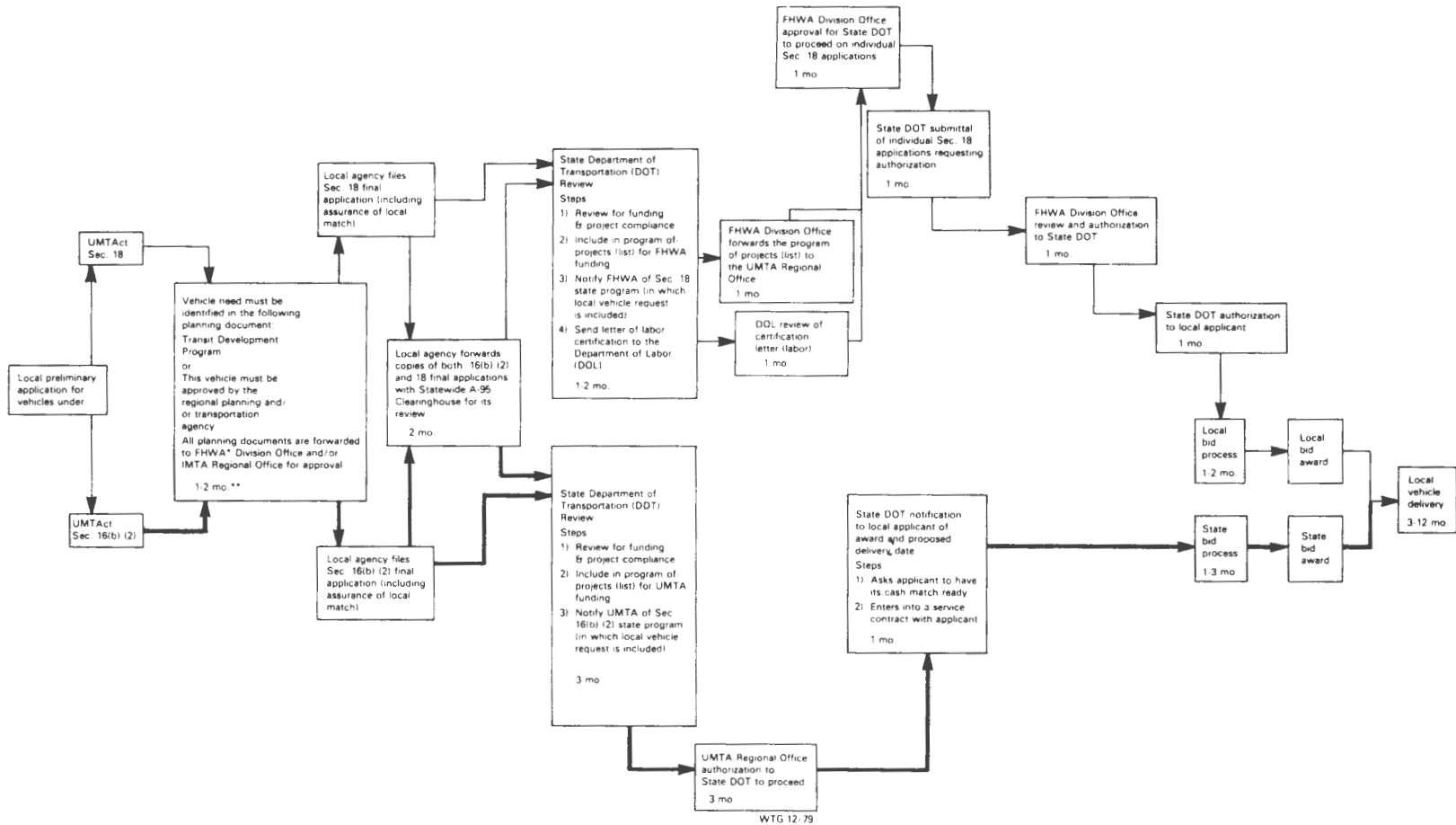

* FHWA = Federal Highway Administration
 **

This represents the approximate (minimum and maximum when two numbers are given) time frame in months for completing a step.

For Sec. 18 the time frame from preliminary application to vehicle delivery is 12-23 months. For Sec. 16(b) (2) the time frame from preliminary application to vehicle delivery is 12-24 months. The maximum times will be required as vehicles requested are customized to meet special needs.

Figure 16. Sample Advertisements (Invitations for Bids)

**STATE OF ILLINOIS
DEPARTMENT OF TRANSPORTATION
DIVISION OF
PUBLIC TRANSPORTATION
NOTICE TO BIDDERS**

Separate sealed bids for:
up to twenty-two (22) buses especially designed to transport elderly and handicapped persons and having a capacity for 12-16 passengers, (Bid Package A)

and
up to thirteen (13) buses especially designed to transport elderly and handicapped persons and having a capacity for 18-24 passengers (Bid Package B)

will be received by the Illinois Department of Transportation at the offices of the Illinois Department of Transportation, Division of Public Transportation, 300 North State Street, Room 1002, Chicago, Illinois 60610, until 11:00 o'clock A.M. (CST), July 23, 1980, and at that time publicly opened and read.

BIDS WANTED

This request for bids is being undertaken on behalf of the purchasers, private non-profit agencies in Illinois whose applications for capital grant assistance have been approved by the federal government under the provisions of Section 16(b)(2) of the Urban Mass Transportation Act of 1964, as amended.

Any and all contracts resulting from these bids are subject to the terms of the financial assistance contracts between the Illinois Department of Transportation and the United States Department of Transportation and between the purchasers and the Illinois Department of Transportation.

The Illinois Department of Transportation, on behalf of the purchasers, reserves the right to reject any and all bids and to excuse non-compliance with formal requirements in the bids and bidding when, in the judgment of the Department, the best interests of the purchasers will be served and the spirit of competition will be maintained.

Any individual, firm, partnership or corporation appearing on the United States Comptroller General's list of ineligible contractors for federally financed and assisted construction is not an eligible bidder.

The Department hereby notifies all bidders that in regard to any contract entered into pursuant to this solicitation for bids, minority business enterprises will be afforded full opportunity to submit bids in response, and will not be subject to discrimination on the basis of race, color, sex, or national origin in consideration for an award.

Within fifty calendar days following the publication of this Notice to Bidders, pre-bid qualifications and certification forms must be completed and submitted to the Department by prospective bidders.

Copies of pre-bid forms and all other bid materials may be obtained from the 16(b)(2) Project Manager, Illinois Department of Transportation, Division of Public Transportation, 300 North State Street, Room 1002, Chicago, Illinois 60610.

Stephen Schindel, Acting Director
Division of Public Transportation

BIDS WANTED

INVITATION FOR BIDS

The Greater Hartford Transit District (the "District") hereby gives notice that it will receive sealed bids for the purchase of up to twenty-three (23) 12-passenger vehicles, seventeen (17) of which shall have wheelchair lifts.

Bids shall be submitted on forms furnished by the District and shall be addressed to:

Mr. Arthur L. Handman
Executive Director
Greater Hartford Transit District
179 Allyn Street
Hartford, CT 06103

Bidders shall submit their bids in a sealed envelope and shall indicate on the face of their bid envelopes the following: "Bid for Lift-Equipped Passenger Vehicles".

Bids will be received up to but not later than 11:00 a.m. local time, October 6, 1980. At that time, the bids will be publicly opened and read aloud at the District's office. Bids must remain in effect for thirty (30) days from the bid opening.

Requests for copies of the Technical Specifications, General Specifications, and Bid Forms and all inquiries related thereto shall be directed to the above addressee. Telephone inquiries may be made to either the above addressee or Mr. Samuel G. Billings, Transit Planner, at (203) 247-5329.

All bids and related documents will be subject to financial assistance contracts between the District and the U.S. Department of Transportation, Urban Mass Transportation Administration (UMTA) and between the District and its local operators. All bidders will be required to certify that they are not on the Comptroller General's list of ineligible contractors. The successful bidder will be required to comply with all applicable Equal Opportunity Laws and Regulations.

Bids must be accompanied by a certified or bank check or acceptable surety bond in an amount not less than five percent (5%) of the total bid price. The check or surety bond will be returned to unsuccessful bidders. Such bid bond received from a successful bidder will be held until said successful bidder furnishes a performance bond with surety or certified or bank check for the full amount (100%) of the contract to the District. Upon receipt of said performance bond, the bid bond will be returned to the successful bidder.

The District reserves the right to accept any bid or reject any and all bids and to waive any irregularities.

Dated: August 12, 1980
By: ARTHUR L. HANDMAN
Executive Director

Note: Both these advertisements appeared in PASSENGER TRANSPORT, v. 38, the first in no. 21, May 23, 1980; the second in no. 34, August 22, 1980.

No. A-104 — Comparative Cost Analysis for Decision to Lease or Purchase General Purpose Real Property

No. A-110 — Grants and Agreements with Institutions of Higher Education, Hospitals, and other Non-Profit Organizations.

UMTA has more detailed regulations for its aid recipients contained in its External Operating Manual Section III-C. Figure 17 lists the types of required clauses and provisions. For all proposed and formally advertised contracts costing more than \$2,500, the manual states that UMTA shall make a prebid analysis and review. The External Operating Manual does not, however, govern the 16(b) (2) program. Recipients of 16(b) (2) funds are expected to follow local bid regulations; UMTA does not review the proposed contracts. The FHWA Section 18 program currently expects that local bid requirements be followed by funding recipients of capital assistance.

Figure 17. UMTA'S Required Clauses and Provisions for Equipment Contracts

<p style="text-align: center;">Advertisement and/or Invitation to Bid</p> <ol style="list-style-type: none">1. Equal Employment Opportunity2. Statement of Financial Assistance3. Ineligible Bidders <p style="text-align: center;">Standard Contract Clauses</p> <ol style="list-style-type: none">1. Contract Changes2. Interest of Members of Congress3. Prohibited Interests4. Equal Employment Opportunity5. Air Pollution6. Motor Vehicle Safety and Pollution7. Cost of Living8. Minority Business Enterprises <p style="text-align: center;">Required Contract Provisions</p> <ol style="list-style-type: none">1. Contract Period2. Termination of Contract3. Nonrestrictive Clauses4. Maximum Compensation

*UMTA 1000.2, Chg. 2, 3-11-74.

Note: Maintain contact with your local UMTA office to keep up to date with the latest developments in the regulations.

Source: Reference 115.

Most bid procedures follow the general process outlined in Figure 18.

Figure 18. Typical Bid Process

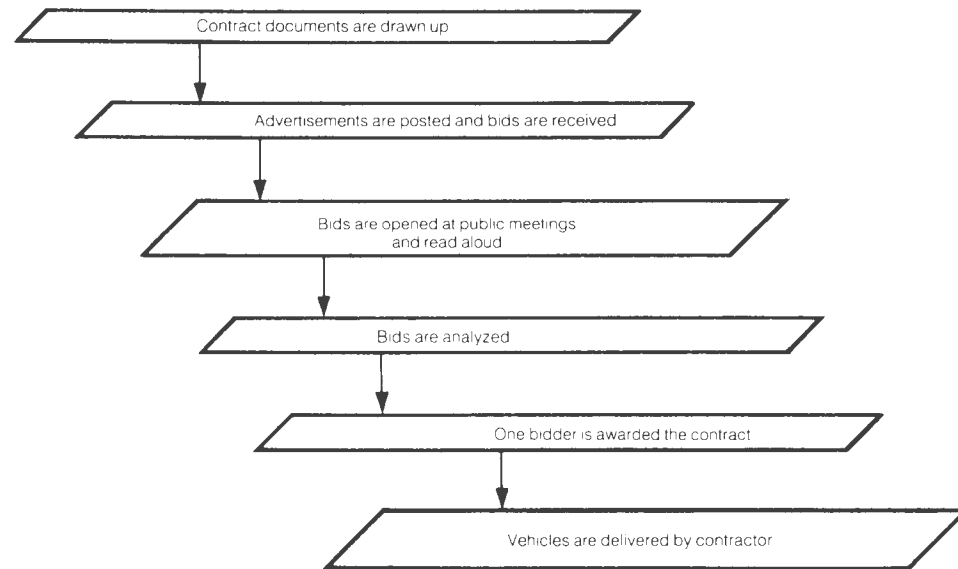

Allowances are usually made in the process for bidders to contest specifications, to ask for approval of what they consider an equivalent specification, or simply to clarify specifications. One method is to have a prebid conference, usually held shortly after bidders have picked up the buyer's proposed contract. This conference provides a forum for the buyer and for the potential bidders to clarify provisions. They may also discuss whether the provisions in the contract are reasonable (i.e., that most suppliers can meet those provisions and bid on the contracts). This encourages greater competition. As a result of this conference, addenda to the proposed contract may be issued.

Another way of eliciting feedback from suppliers is to ask them to submit written comments soon after the bid opens. The buyer's analysis and comments may result in amendments to the contract.

The time taken by the bid process varies depending upon the regulations a buyer is following and upon the time constraints a buyer has set. Figure 19 shows

Figure 19. Sample Bid Process Timeline

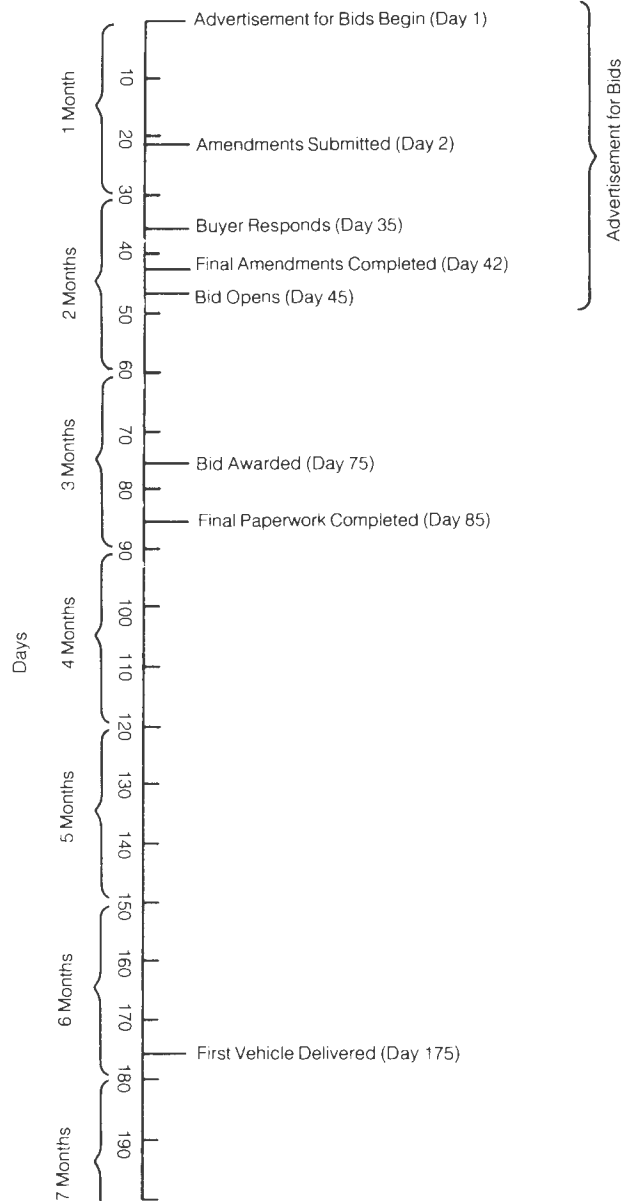

the bid process used by one state agency in procuring vehicles under the 16(b) (2) program (22).

The delivery time, the time between the awarding of a contract and vehicle delivery, can be specified by the buyer in the proposed contract. Alternatively, a buyer may allow the bidders to set the time in their bid. One advantage of this is that the proposed delivery time, like the price, becomes an item for comparison in the bid analysis. It may also keep bid prices lower, because bidders may raise prices in an effort to meet a buyer's early completion data (65).

Suppliers have indicated that delivery can take anywhere from 2 to 12 months, with delivery for small buses averaging around 12 months. This depends on the suppliers' manufacturing capacity and on their ability to obtain the chassis (in the case of modified vans and body on chassis) and parts. Sometimes conditions beyond the suppliers' control delay delivery; labor strikes, for example, can delay the suppliers' receipt of parts. Although provisions can be included in a contract for a supplier to pay for damages resulting from a delay in delivery, many operators feel that the inconvenience to their service caused by a delay cannot be adequately rectified by liquidated damages.

SIZE OF ORDER. In general, the larger the purchase order, the lower the price of each vehicle. It may also be less expensive to get a vehicle with special specifications or options if a large number of these vehicles are ordered at one time.

In this regard, Caltrans has considered investigating the possibility of a small transit vehicle consortium among several states (19). It believes that joint purchasing should improve vehicle quality and lower the cost.

On the other hand, large orders may lengthen the delivery time for the full order. For example, when the Iowa Department of Transportation procured vehicles for their 16(b) (2) program applicants in years past, procurement time was from 15 to 18 months. During the first year in which applicants procured their own vehicles, delivery took only from three to six months (20).

CONTRACT DOCUMENTS. Contract documents are comprised of two major parts, the front-end documents and the technical specifications. Buyer inexperience in writing the contract, and especially the technical vehicle specifications, has resulted in delays. Some of these inexperienced buyers have speeded their procurement by using state and local highway or transportation departments to assist them. In many states, it is the state agencies or experienced transit authorities which actually handle the procurements (3).

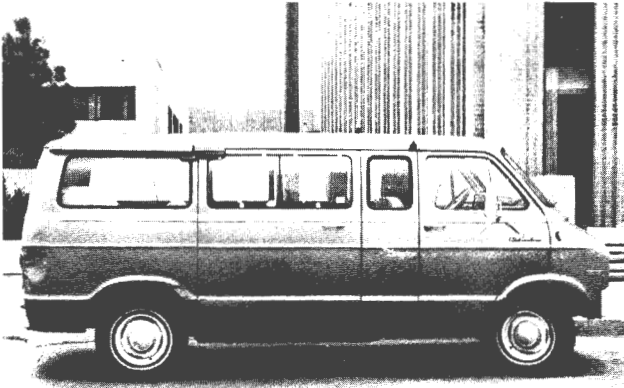

1. Front-end Documents

The type of contract documents and phrases used vary. However, there some basic components of the front-end documents.

- Instructions to bidders — details the bid process, including qualifications expected of bidders, bonding information, data to be submitted with bid, how a bidder can request clarification or addenda, etc.
- General provisions — details the role of buyer and supplier in the contract concerning items such as payment, delivery, inspection, termination of contract, warranty; also state and Federal provisions.
- Bond forms — Bonds provide collateral against a bidder's failure to perform. There are three types in common use. A *bid bond* guarantees that the bidder will sign the contract if awarded the project. A *performance bond* guarantees that the supplier will complete the project. And a *payment bond* guarantees that the supplier will pay for all labor and material used in the project.
- Bidder's proposal — lists what the bidder will provide, such as the quantity of items to be produced, prices, technical specifications, servicing and parts, etc.

There is one general provision which deserves a separate discussion, because it has been a problem in many cases. It has been reported that problems have arisen from the *warranty* agreements for modified vans and body on chassis (102). The chassis and bodies are generally manufactured by different companies and each manufacturer warrants his own product. A wheelchair lift may be warranted by the vehicle supplier; otherwise repairs under warranty are done by the original manufacturer. In areas where chassis or body dealers are not readily available, arrangements can be made for local mechanics to perform repair work and be reimbursed by the manufacturer under the terms of the warranty.

The real inconvenience to the buyer is not the need to deal with several dealers, but the disputes which arise when responsibility for a defect is unclear. The disputes can result in delays in repairs. A warranty agreement designating the supplier as responsible to the buyer for all warranty work has been used to alleviate this problem.

2. Technical Specifications

Technical specifications are the part of the contract which determines the actual components, construction, and performance requirements of the vehicles. Specifications can be phrases or drawings.

Specifications can vary in the items included and in the style of presentation. However, specifications do follow a general pattern. Appendix E contains a sample outline of a technical specifications document.

Specifications can dictate a design standard or a specific performance level. For example, the following two specifications concerning axle capacity show this difference.

- Design oriented*
“Front axle capacity 4,000 lbs minimum
Rear axle capacity 11,000 lbs minimum”
- Performance oriented**
“The combined front and rear axle capacities, as rated by the axle manufacturers, must equal or exceed the total “net” curb weight of the coach, plus a full seated load, plus standing passenger load of 50 percent of seated passenger load, plus operator, at 150 pounds per person.”

Buyers have noted that it is desirable to allow the supplier flexibility in construction and not to eliminate bidders who can meet the desired performance level but not a strict standard. When specific figures are used in a specification they are often written as a minimum standard, or expressed as a range between a minimum and maximum. On the other hand, the specification should be tight enough to guarantee that the low bid a buyer accepts is for vehicles of the quality desired.

BID ANALYSIS. In general, bid analysis requirements set the low bid (lowest-priced vehicle) as the basis upon which a contract is awarded. UMTA requires that awards be made to the “lowest responsive and responsible bidder”; otherwise, UMTA approval is necessary (115).

One alternative is to use the life-cycle of the vehicle, rather than the initial cost, as the determining cost. Life-cycle costs include the acquisition costs, operating costs, and maintenance costs; in other words all the costs associated with a vehicle’s useful life.

Appendix F contains one method useful for computing life-cycle costs. (See Figure 20.) However, it is difficult to document these costs, and disputes concerning figures may not be easy to resolve. In addition, operators have claimed that their budget constraints do not permit the acquisition of a vehicle which has a high initial cost even though it may be less expensive in the long run.

**Specifications for Two Specially Equipped Vehicles Designed for Transporting Handicapped Persons.* Massachusetts Bay Transportation Authority, Jan. 18, 1978.

**Wisconsin Department of Transportation. *Basic Specifications for Mini and Conventional Buses*, 1980.

Figure 20. Computing Life-Cycle Costs

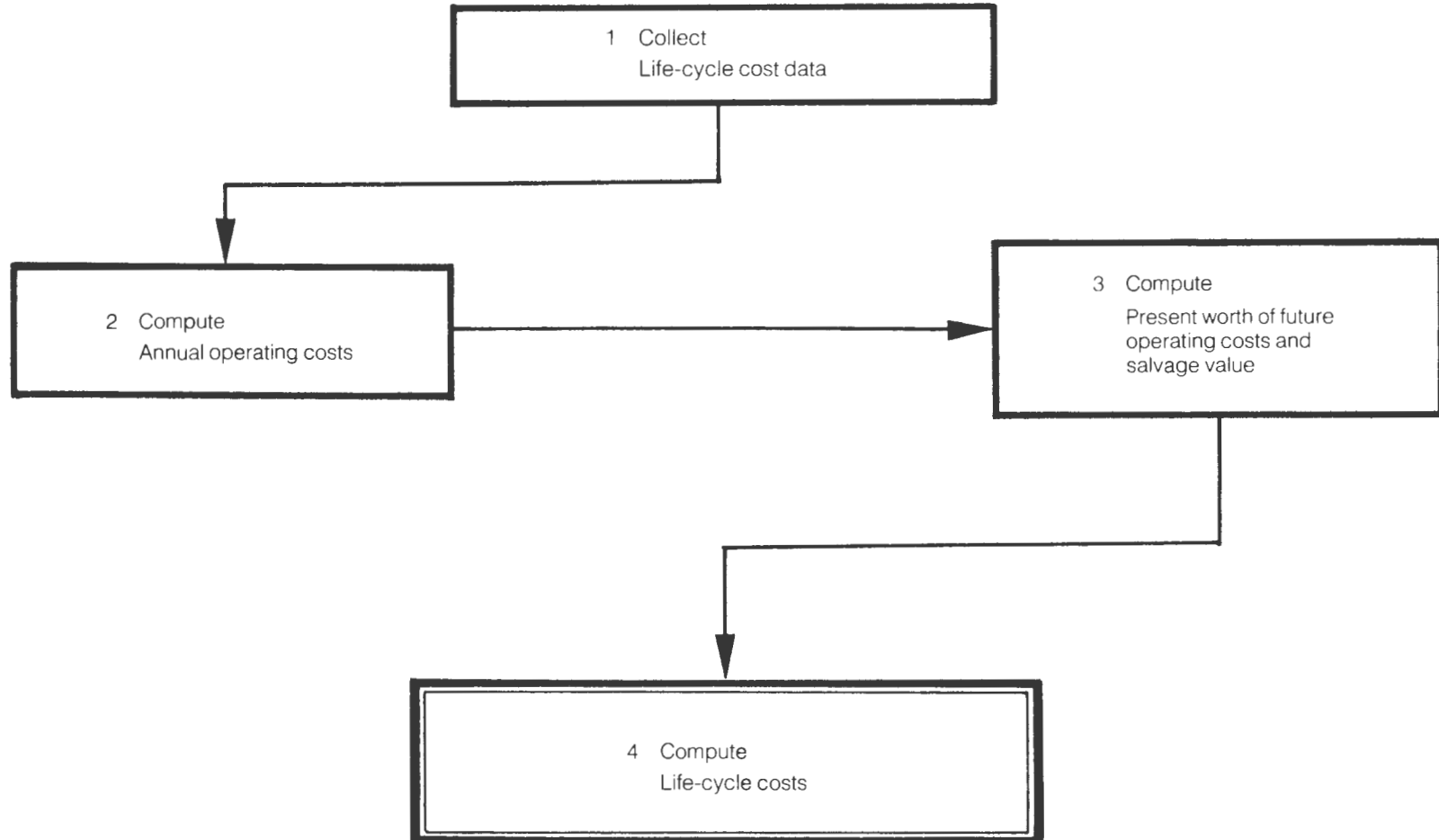

Other considerations have been used in the award analysis, such as the delivery time, the warranty, and the capability of a supplier to handle the order size. The use of these considerations in the bid analysis is usually indicated in the proposed contract documents.

VEHICLE ACCEPTANCE. Many operators recommend inspections upon delivery before final acceptance. Inspections include test drives and visual examinations (37, 69). Appendix D contains a sample inspection checklist.

There are two major reasons for inspections. The first is to assure supplier compliance with the specifications in the contractual agreement. The second is that a number of vehicles have defects upon arrival. Fortunately, a majority of the defects are minor, and can be corrected by the operator. For example, poor workmanship has produced problems such as headlights which do not work, oil dipsticks which are not reachable, bolts which are loose, etc.

Repairing the vehicle in house or sending it back to the dealer or a local mechanic for repairs may delay its entrance into service. However, correcting defects upon delivery can avoid unexpected and more costly problems later on.

When the operator does not have the capability, inspections can be done by state agencies or a transit authority, by local agencies employing mechanics, or by local mechanics.

On-site inspections, having an inspector selected by the buyer to monitor the vehicles as they are being manufactured, has been suggested as a method to avoid vehicle problems upon delivery. However, not only is it costly, but it is not generally favored by suppliers and it does not always guarantee that a vehicle will be free of defects.

funding sources

Almost no public transportation systems are self sufficient through fares. To obtain revenue, systems draw from a variety of sources, such as:

- Trade membership dues
- Advertisement sales
- Contracting out services or equipment
- Individual contributions
- Volunteer labor (an indirect source).

Most systems, however, rely on Federal, state, and local governmental subsidies. Subsidies are particularly important for systems which are just starting a service and thus want to minimize financing costs, but which haven't yet built up capital.

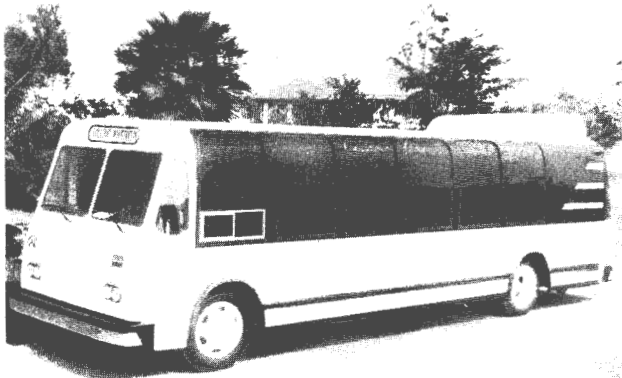

FEDERAL. In 1977, the U.S. General Accounting Office identified 114 programs within 11 Federal departments which provide operating or capital assistance for transportation (105). The Department of Health and Human Services and the Community Service Administration handle a majority of these grant programs. Most of these programs designate the eligible passengers or the site to which passengers can be transported. Those sites are generally health, education, vocation, social service, or rehabilitation centers. These programs were designed to supply some type of social service, not transportation. The money allocated for transportation is intended to facilitate the clients' access to these social services. Many of the programs do not provide capital assistance, providing instead assistance for clients to use existing transportation services.

Another major source of Federal funds is the Department of Transportation. Unlike the programs above, the primary intent of DOT programs is to assist in providing transportation. Within DOT, funds for nonurban areas (with a population of less than 50,000) are available from the FHWA. The money is administered under the Section 18 program of the Surface Transportation Assistance Act (98). Prior to 1978, when this section was enacted, nonurban areas relied mostly on social service grant programs and on UMTA's Section 16(b) (2) program for capital assistance in transporting elderly and handicapped people (101). Section 18 marks the beginning of a Federal commitment to aid public transportation in nonurban areas.

Both capital and operating assistance is available through Section 18. Systems apply for funds through state governments, which are the initial recipients of this formula grant. Eligible recipients include public bodies, nonprofit organizations and transportation operators. Private (for profit) providers are eligible, through purchase-of-service agreements with a local public agency, for the provision of public transportation services. The Federal government matches 50 percent of operating expenditures and 80 percent of capital expenditures.

UMTA, which is part of DOT, allocates capital assistance under Sections 3, 5, and 16 of the Urban Mass Transportation Act of 1964, as amended.

Section 3 is a discretionary capital grant program subsidizing state governments and local public bodies. Private transit operators may receive capital grant money by lease or by other arrangements from public agencies that receive UMTA grants. The Federal share of capital project costs is 80 percent.

Section 5 gives both capital and operating formula grants to public agencies through a state agency designated by each governor. Section 5 only disburses money to urbanized areas. Eighty percent of capital costs and 50 percent of operating costs of projects are granted.

Section 16 authorized UMTA to make capital grants to local, nonprofit agencies to meet the special needs of elderly and handicapped persons. Section 16(b) (2) allocates funds for capital assistance; applicants apply to UMTA through their state governments.

STATE. State governments are becoming more involved in assisting transportation services. Most states provide capital and operating assistance generated from general revenue sources (e.g., state gasoline sales, and property taxes). In addition, a number of states earmark for transit part or all of the proceeds of specific taxes (45). Some states pay all or part of the local matching share for Federal capital grants (45).

A recent study surveyed 25 states to examine the transportation assistance provided. (53.) Twelve of the states reported no expenditures for capital assistance. Many of those states had laws explicitly preventing state funding for Federal programs. However, most states had made arrangements for channeling local funds to provide the non-Federal match for UMTA programs when the state was prohibited from owning vehicles or from providing capital assistance.

Most states use their capital grants assisting transportation to pay for buses. (45). With the Federal government paying 80 percent of capital project costs, the local matching amount required for bus replacement in most systems can be financed out of current funds rather than through state or local borrowing (45).

Many sources believe that the Section 18 nonurban public transportation program will encourage additional state involvement.

LOCAL. A recent study found that transportation systems using local funds tend to have a greater degree of local commitment, community control, and support than systems which rely solely on state and Federal support. (9)

Local public funds currently used for transportation services include property taxes, sales taxes, special district taxes, and other sources. Some localities also use part of their Federal formula block grants, such as the community development block grants and revenue sharing (52). However, rural communities having a population of less than 75,000 people rarely vote funds for generalized transportation (52). Nonurban areas receive a good amount of assistance from the Federal 16(b) (2) program, which provides nonprofit agencies with capital assistance for transporting elderly and handicapped persons. Unfortunately, many recipients do not budget for depreciation to plan for vehicle replacement and, in most cases, the local governments do not budget for this capital expenditure (53). Grant recipients tend to rely on future grants from the Federal (16) (2) program to provide 80 percent of the cost of a replacement vehicle.

IV OPERATIONAL CONSIDERATIONS

ONCE A VEHICLE has been selected and acquired, it is best to put it into service as quickly as possible. However, there are aspects of vehicle operation that should be considered before a vehicle is in service. Adequately preparing for vehicle-related costs, maintenance service, driver training, and insurance, can help to ensure an efficient and safe service.

financial considerations

COST ITEMS. There are many expenses associated with acquiring and operating small transit vehicles. Figure 21 lists many of the common cost items, dividing them between capital and operating costs. Capital costs are the purchasing costs for vehicles, facilities, and equipment needed to make a transit system operations. Operating costs include the day-to-day costs of running a system. (Figure 22 contains 1980 prices for vehicles.)

Depreciation deserves some comment here, because it is a controversial cost category. Many systems relying on Federal funds do not use depreciation in their cost accounting since they follow Office of Management and Budget Circular 74-4, Attachment B, which forbids the computation of depreciation on equipment paid for directly or indirectly by the Federal government. Proponents of the use of depreciation in cost accounting see two major advantages of a system recording depreciation:

- It permits systems to recover from other agencies that portion of their own vehicle which is used by other than their own clients (82).



- It could encourage the saving of money for vehicle replacement.
(For further discussions of depreciation see References 82, 83, 54.)

It would seem that average expected costs applicable to all systems could be arrived at by examining and comparing the costs of several systems. However, these comparisons are difficult to make, particularly among social service agencies, due to: (81)

Figure 21. Vehicle-Related Cost Items

Capital Costs	
Vehicles (Including Options Such As: Air Conditioners, Wheelchair Lifts, Radios, etc.)	
Maintenance/Storage Facility	
Maintenance Equipment	
Operating Costs	
Labor, Salary, and Fringe Benefits (for Drivers, Dispatchers, Mechanics)	
Training	
Vehicle Depreciation	
Vehicle Lease	
Insurance	
Licenses, Registration	
Taxes, Tolls	
Fuel, Lubricants, Tires	
Maintenance/Storage Facility Rental	
Maintenance Equipment Rental	
Tools, Parts	
Maintenance Utilities	
Maintenance Service Contract	

Figure 22. Vehicle Price Ranges

Vehicle Type	1980 Price Ranges (in Dollars*)
Modified Van	16,000 - 29,000
Body on Chassis	14,000 - 90,000
Small Bus	72,000 - 125,000

*Prices vary according to the special modifications and options included in the vehicle package.

- Accounting variations, including:
 - Variations in accounting definitions
 - Variations in the coverage of accounts (e.g., some systems are not permitted to cover depreciation)
 - The exclusion of some transportation costs and the inclusion of non-transportation costs in transportation cost accounts;
- Operating data insufficient to permit evaluation and monitoring of system operations
- The difficulty of making comparisons between systems because of:
 - Differences in the time covered by data and accounts (e.g., because of inflation or other time-related cost differences)
 - Differences in the length of operating experience so that system averages may not be representative
 - Variation in the markets served (e.g., rural versus urban)
 - Variation in the type of service or service mix, and
 - Differences in vehicle type and vehicle mix between projects.

A recent study was conducted of the transportation costs of 56 systems serving elderly and handicapped people (83). These systems included social service agencies, transit properties, and agencies utilizing service contracts. It attempted to reconstruct costs and add missing costs to get comparable categories. The cost categories examined were:

- Equipment depreciation
- Overhead
- Maintenance
- Operating salaries.

The pie charts in Figure 23 show the percentage of the total cost that each category held.

Another way to look at costs is to convert costs based on time periods (i.e., monthly, or annual costs) to unit costs. Unit costs are useful in measuring and evaluating the operating performance of a system. The unit costs relevant to the evaluation and comparison of vehicles is the cost per vehicle hour and the cost per vehicle mile or vehicle kilometer. The operating (or total) cost per vehicle hour is equal to the total cost divided by the number of hours the vehicles were in operation. The operating (or total) cost per vehicle mile is equal to the total cost divided by the number of miles the vehicles have traveled. An evaluation of FHWA's Section 147 Rural Transportation Demonstration Project established probable ranges for costs of rural transportation systems (12). (See Figure 24.)

Figure 23. Transportation Costs of 56 Systems Providing Transportation for Elderly and Handicapped People

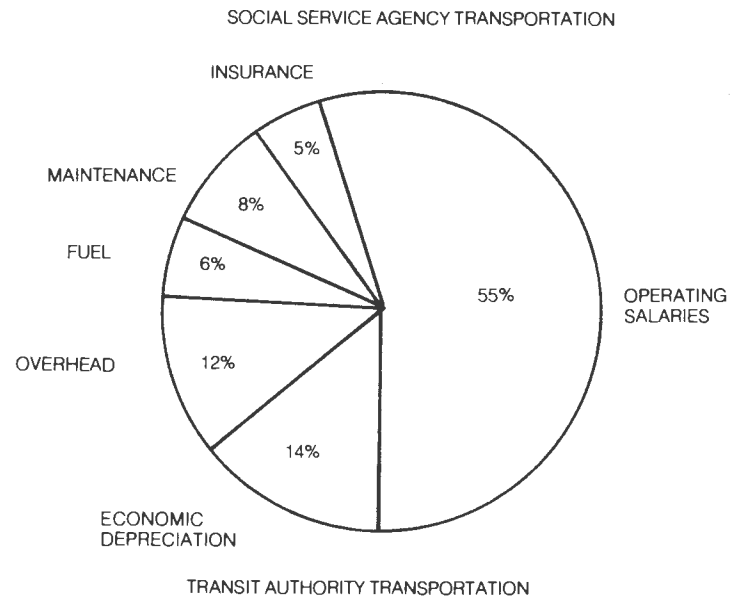
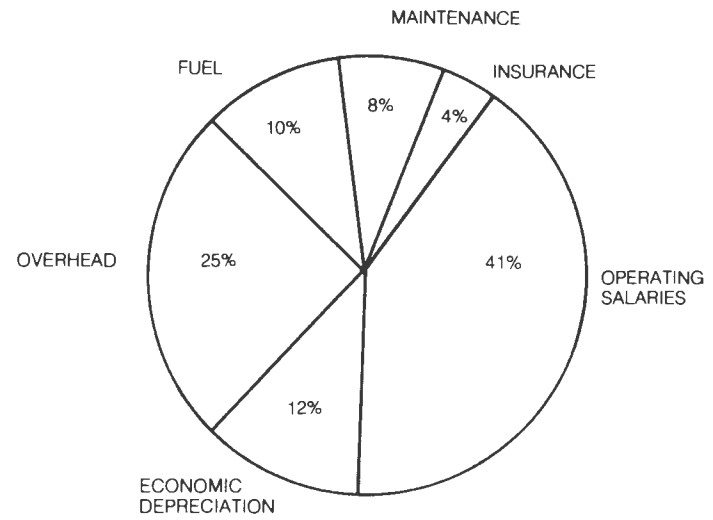



Figure 24. Sample Ranges of Unit Costs for Rural Transportation Systems

	LOW	HIGH
COST PER VEHICLE MILE*	\$0.36	\$ 1.06
COST PER VEHICLE HOUR*	\$6.52	\$20.51
MONTHLY VEHICLE MILES	1,841	3,238

*Operating, capital, and administrative costs are included.

Source: Reference 61.

In urban areas, the cost per vehicle hour is a more useful measure than the cost per vehicle mile, because the operating vehicle may not actually be moving but may still be "in operation," (i.e., the vehicle is waiting in traffic, standing, or loading and unloading) (46). On the other hand, the cost per vehicle mile is useful in determining the effects of a change in the service level, or miles traveled.

FACTORS WHICH AFFECT COSTS. There are several factors which affect the vehicle operating costs:

1. Type of Vehicle

Figure 2 shows how the cost per vehicle kilometer varies according to the type of vehicle. In addition, life-equipped vehicles cost more to acquire, require more fuel, and usually carry higher insurance costs (83).

2. Age of the Vehicle

As the age of a vehicle increases, operating costs also increase (11,102). Specifically, age has a significant effect on vehicle maintenance, but generally not on fuel economy (64).

3. Traveling Speed and Operating Environment (11)

- Fuel consumption increases as speed increases.
- Fuel consumption increases as the quality of the road surface decreases.
- Costs for engine oil, tires and tubes, and vehicle repairs, increase as the quality of the road surface decreases.
- Fuel consumption increases as the terrain becomes more hilly.

4. Preventive Maintenance Program

An effective preventive maintenance program can help a vehicle run efficiently and avoid breakdowns and costly repairs.

5. Proper Vehicle Handling and Driving

A good driver can minimize accidents and vehicle wear. The U.S. Department of Energy in a Driver Aid and Test Project conducted from 1976-1978 found that trained drivers could increase the miles per gallon of a vehicle on the average by 10 percent (103).

6. Unionization of Drivers

Unionized drivers often have higher wages than nonunionized drivers (9,83,116). Labor contracts may require a full day's salary for drivers regardless of how many hours the vehicle is in operation. An evaluation of the LIFT program in Portland, Oregon determined that the allocation of driver hours based upon union work rules was 20 percent more than needed to provide the service (25).

7. Inflation

Costs for labor, equipment, oil, and fuel are rapidly increasing. Figure 25 shows, for example, increases in diesel fuel.

maintenance

SERVICE ARRANGEMENTS. A complete maintenance facility for a transit bus consists of: (7)

- A storage garage
- A service area for daily fueling, cleaning and inspection
- A periodic inspection area
- A bus repair area
- A component unit repair-and-rebuild facility.

However, many of the systems which utilize small transit vehicles do not have a fleet large enough to justify the costs of, or the space needed for, a complete facility. In these cases service must be obtained outside the organization. Many systems have a maintenance operation which performs some routine work and minor repairs in house and which contracts out for major repairs. Figure 26 contains examples of work that may be contracted out.

Contracting out for service has the advantage of lessening the requirements for maintenance personnel, inventory control capability, shop equipment, and maintenance facilities (33). Another major advantage occurs with vehicle maintenance contracts which provide for periodic, lump-sum payments. In these cases an operator is permitted to budget fixed amounts for maintenance rather than make payments based on service received (63). This helps a system avoid cost overruns and cash-flow problems.

A Maintenance Facility

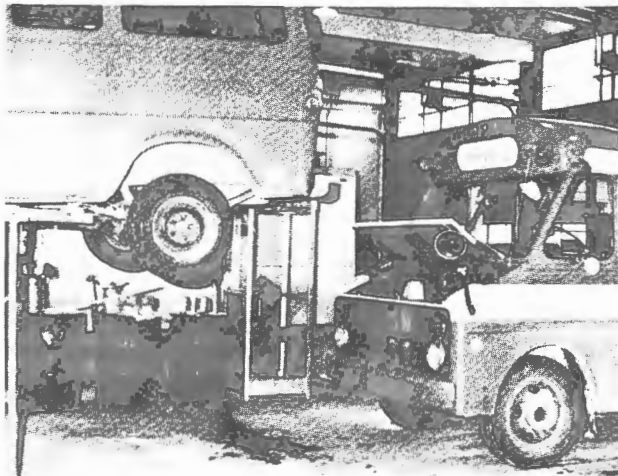
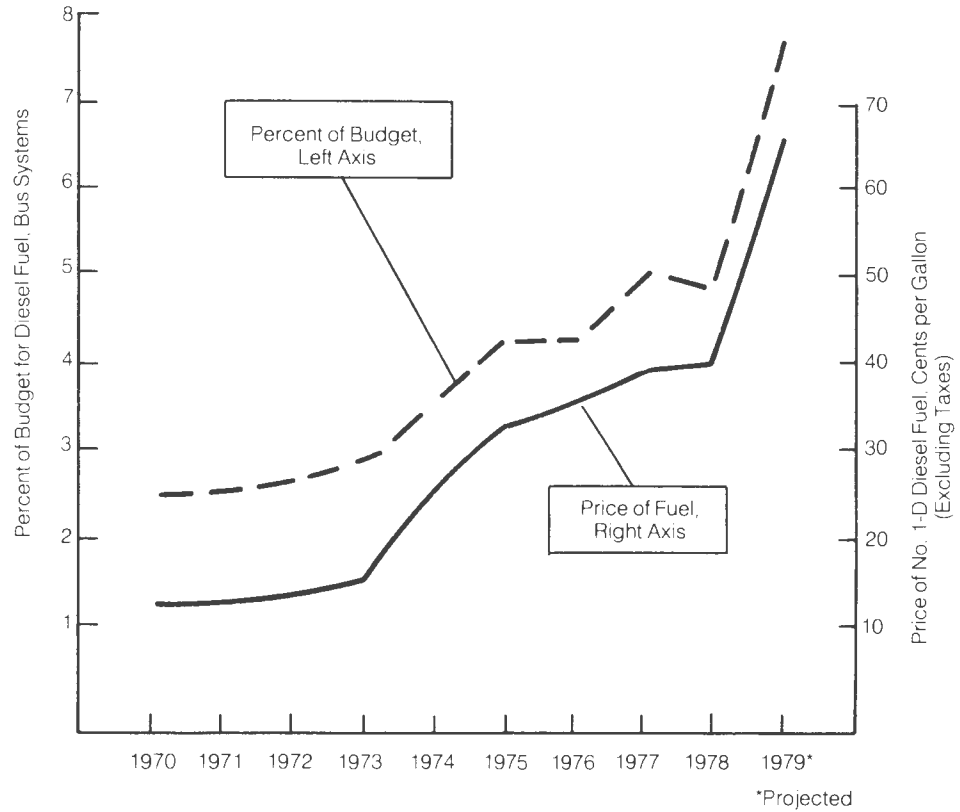

Figure 25. Motorbus Diesel Fuel Costs

The fastest growing cost for bus transit systems in the last decade has been motor bus fuel. Most transit systems use No. 1-D diesel fuel, a highly refined middle distillate that minimizes air polluting emissions from buses. The cost of No. 1-D diesel fuel has risen 450% in the last nine years from 12 cents per gallon excluding taxes in 1970 to 65 cents per gallon excluding taxes in the summer of 1979.

This incredible price increase of diesel is five times as great as the Consumer Price Index which rose only 88% during the same time period. Because fuel costs are rising more quickly than inflation, they are becoming a much larger portion of transit system expenses.

In 1970 diesel fuel costs accounted for 2.5% of transit system budgets for motor bus operations. By the summer of 1979 diesel fuel accounted for 7.7% of the cost of motor bus operations. The rising portion of transit expenditures going to diesel fuel requires transit systems to economize in other areas to help prevent excessive cost increases while continuing to improve transit service to their communities.



Source: Reference 4.

Figure 26. Examples of Work That May Be Performed by Outside Agencies

- Heavy engine and transmission repairs/rebuilds
- Air-compressor repairs
- Cylinder reboring
- Armature rewinding
- Crankshaft turning
- Bumper replating
- Radiator repairs
- Fuel-injector rebuild
- Radio repairs
- Air-conditioner repairs
- Fare-collection equipment repairs
- Paint work
- Body and upholstery repairs
- Brake reline/rebuild work
- Preventive and motor inspections and periodic servicing

Source: Reference 33.

On the other hand, having an in-house facility can have the following advantages:

- Vehicles get priority attention.
- Routine servicing can be scheduled more easily so that the transit service is unaffected.
- The operator can have quality control over the maintenance operation.
- It may be less expensive.
- Extra revenue can be generated if other agencies contract for the use of the maintenance personnel and facilities.

(See Figure 27 for the components involved in planning either option.)

PROVIDERS OF MAINTENANCE SERVICE. There are a number of different types of organizations which provide maintenance service. Following are examples of places where service can be obtained.

1. Private Garages and Gas Stations

Bids can be accepted for maintenance service by private garages. Some operators have kept costs down by receiving discounts from them. For example, the Regional Transportation Program (RTP) in Portland, Maine, received through its service contract: (21)

- A 10 percent reduction for labor costs
- A 20 percent reduction for parts
- Gas priced at only two cents over the wholesale cost.

Figure 27. Components of a System for Maintenance Planning

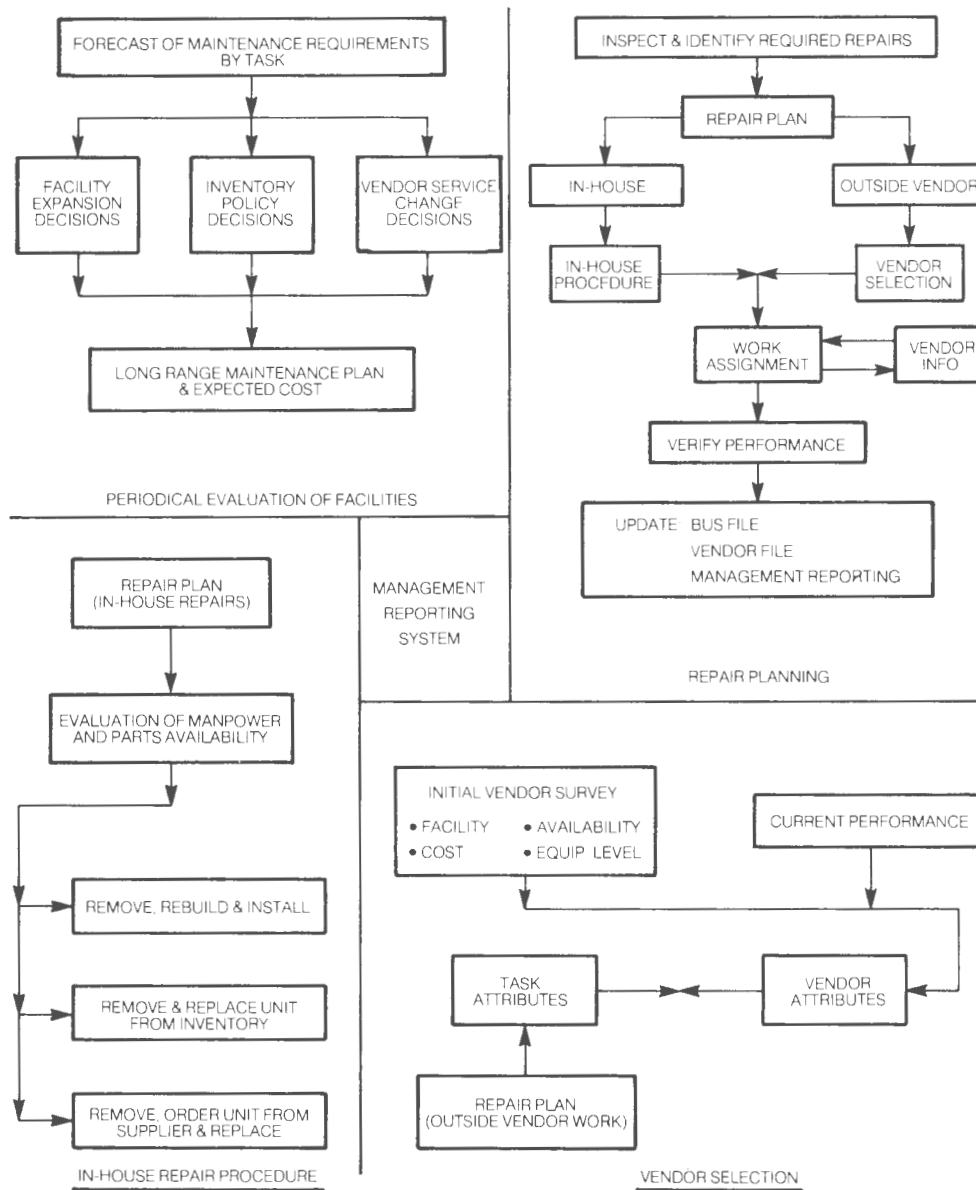

Source: Reference 7.

RTP's mechanic agreed, by contract, to these provisions, providing RTP obtained its regular services and all of its gas from him. RTP used specialty shops and other businesses for its major component (e.g., engine and transmission) repairs.

2. Dealers

Arrangements can also be made with the vehicle dealers. This has worked out especially well for warranty repairs. (43). However, this arrangement is usually only available for standard vans.

3. State or Local Agencies

Some agencies, such as state or county highway departments and school system bus contractors, have their own vehicle fleets which they service themselves or contract out to have serviced. Operators can join with these agencies and receive the service. Sometimes they also receive discounts on parts. For example, a group of organizations coordinated their purchasing and received a state discount number to purchase tires, batteries, anti-freeze, and other equipment from a supplier who handled the state highway department vehicles (12). This resulted in a 40 percent savings to the organizations.

4. Transportation Authorities

Some services are overseen by transit authorities and contracted out to an organization which operates the service. The contracting organization may handle maintenance.

Small system operators may contract with a transit authority for service. However, since most of the small vehicles are gas powered, transit authorities may not have the equipment or training necessary to service them (55). In addition, some operators have said that transit authority labor costs are higher than those of other businesses or system operators.

5. Other System Operators

Other system operators may have extra storage and/or service capacity which they contract out to gain additional revenue. Paratransit, Inc., for example, which runs a paratransit service in Sacramento, California, has approximately 20 non-profit agencies (about 100 vehicles) under contract for maintenance services. Paratransit, Inc. provides its customers with two contract options; one is a preventive maintenance program through which services are performed at predetermined mileage intervals for a flat monthly fee; the other is a fueling and safety-inspection agreement under which an agency purchases fuel and oil and is required to bring vehicles in for a safety inspection at specified intervals. A recent evaluation of Paratransit, Inc.'s program found that participating operators save on fuel, oil, labor, and parts (86). In addition, there are nonfinancial benefits to operators, including an improvement in the condition of the vehicles, the guaranteed availability of fuel during fuel shortages, and the consolidation of billing (coupled with

the ability of Paratransit, Inc. to carry outstanding balances). The Paratransit, Inc. service center operates without subsidy.

6. Coordination by System Operators

System operators can join together to coordinate their maintenance needs and select a common maintenance service provider. A coordinated maintenance service offers regularly scheduled preventive maintenance, nonscheduled repairs, emergency road service, and complete recordkeeping for vehicle performance and repairs (5).

The Community Resources Group (CRG) in Springdale, Arkansas, is an example of this type of coordination (18). CRG originally coordinated parts purchasing in order to get parts at wholesale prices. At present it also provides maintenance services. CRG claims that with 16 agencies participating in the joint purchasing and maintenance program they have saved about 51 percent in costs (106).

7. Local Schools

Some community colleges or vocational schools have training programs for maintenance personnel. A recent study reported that a system operator in Michigan found a maintenance agreement with a local community college technical-training program to be a cost-effective effort (12).

Another study reviewing innovative approaches to rural transport found two systems which used vocational schools. One of the systems, however, expressed dissatisfaction and switched to a local garage (63).

MAINTENANCE SCHEDULES. The common approach to maintenance scheduling is to assign inspection and servicing for different components on a vehicle at fixed mileage intervals (7). Scheduling regular maintenance inspections rather than waiting for breakdowns is called *preventive maintenance*.

There are several advantages to this system:

- Regularly scheduled maintenance improves learning, reduces labor costs, and lessens chances for error in maintenance.
- A parts inventory can be maintained with greater certainty, reducing the costs of procuring parts and improving bus down time (time a bus is out of service due to mechanical problems).
- A haphazard approach to maintenance contributes to poor vehicle performance and rapid deterioration (12,55,102).
- Breakdowns discourage passengers and can leave the driver and passengers stranded. Demand-responsive services are more adversely affected by on-the-road vehicle breakdowns than fixed-route services, which can compensate by lengthening headways (55).

A survey of transit systems revealed systems choose different mileage intervals for preventive maintenance (8). The differences in mileage were attributed to differences in the types of routes covered, the average distance between stops, the number of passengers carried, the road conditions, and traffic density.

There are innovative systems which attempt to tailor schedules for preventive maintenance to each vehicle, but these may require special equipment, such as on-board monitoring equipment in conjunction with periodic exams, or computer programs which can prescribe schedules (7,8).

An evaluation of the Westport, Connecticut Integrated Transit System recommended that an operator set up a preventive maintenance program before vehicle delivery since there can be "break-in" problems in the first few months of vehicle operation. during that time the public's perception of system reliability can be strongly influenced (35).

In addition to scheduling maintenance at prescribed mileage intervals, preventive maintenance can be scheduled at prescribed time intervals. Examples of daily, weekly, and monthly inspections used by different operators are in Appendix D. Generally, the longer the time interval, the more detailed and comprehensive the inspection (i.e., a weekly inspection is more detailed than a daily inspection). Drivers are sometimes expected to perform these inspections, along with such minor services as keeping the vehicle clean and adding oil and other fluids. System operators may also rely on the drivers to report problems which need to be serviced. The conscientiousness with which drivers report problems early has been evaluated from maintenance repair records, as have the driving habits of the drivers.

Driver Training Course Brochures

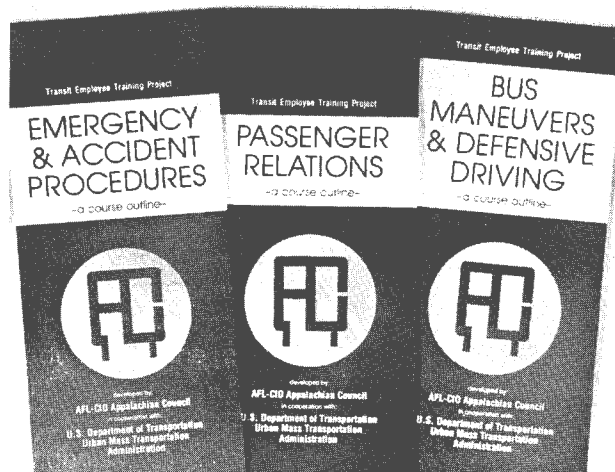

driver training

Driver training is used to achieve several goals:

- Good management and labor relations
- High quality service
- Safe service
- Cost efficiency.

The type of training a system chooses in order to achieve these goals depends on the type of service to be provided, the type of passengers, the funds available for training, the time available to free drivers from regular schedules, and the role the system managers want the drivers to have within the system.

There are several types of training:

- Driving maneuvers and defensive driving to prevent accidents

- First aid, cardiac-pulmonary resuscitation (CPR), and other emergency handling techniques
- Passenger relations, passenger assistance techniques, and sensitivity for elderly and disabled passengers (38,44,47)
- Handling of special equipment, such as wheelchair lifts (30)
- Basic maintenance and vehicle inspection to keep vehicles running safely and efficiently
- Driving techniques to save fuel and money (103)
- Recording of basic data for subsequent evaluations of service and vehicle performance.

Some systems and state departments of transportation have their own training programs and manuals (10,16,58). Other systems, particularly small systems, tend to use a form of on-the-job training in which a new driver observes a veteran driver for a week or so, following which the new driver drives while the veteran driver watches. However, regardless of the training program, new drivers are expected to take several months to become familiar with the service area (27,60,71). Special skills, for example defensive driving and first aid, are taught by local agencies such as the Highway Patrol and the Red Cross.

One of the major barriers to implementing a driver-training program is the money and time necessary to relieve a driver from service in order to attend training sessions. For example, a course called the Passenger Assistance Techniques (PAT), developed by a private consulting organization, has a 10-hour training session (100). The developers of this course believe that the feasible approach to driver time constraints is to train instructors who can in turn teach the course to their system's personnel. This was the approach used by a nationwide driver-training program sponsored by UMTA. Several regional training sessions were held in 1980. This training was designed for drivers of standard transit buses, but those involved with the course say drivers of small transit vehicles, particularly small buses, would find such training useful.

insurance

Insurance for vehicles has been a serious problem for many transportation providers. (See references 29,107,108,109,111). Systems run by transit authorities, and systems which can be included under the blanket coverage of state or local agencies, do not have difficulty. The systems which experience insurance problems are rural and human service agencies, particularly those which are just starting out. The major difficulties encountered by these systems are:

- Limited Availability — A restricted number of companies may be willing to insure the system.
- High Costs — There is a wide range in insurance costs per vehicle among systems and states. In addition, insurance is a high expense for many systems.
- Cancellation — Policies have been cancelled for reasons not always understood by the system.
- Restrictions — Insurance companies place restrictions on the systems' drivers, the charging of fares, the use of another system's vehicles, and the size of the geographical area in which the vehicle can operate.

Two major trends have brought about these problems. First, human service transportation providers are expanding into a public transportation role, and second, for-hire commercial transportation by private for-profit companies is being supplemented or replaced by government subsidized or operated transportation in rural areas. With these changes, the insurance industry is uncertain as to which legal doctrines of liability will prevail. The problem is further complicated by the lack of a sufficient actuarial data base.

These problems, however, are being addressed in a number of ways:

- The Insurance Services Offices of New York (a private nonprofit organization supported by the insurance industry) has filed two new programs which will be effective nationwide (106). The first program adopts a new form of insurance for social service agencies, intended to minimize uncertainty about rates. Rates are expected to fall between those for school buses and those for standard city buses. The second program provides additional liability insurance for vehicles owned by agency employees and volunteers which are used to transport agency clients.
- System operators are practicing risk management by instituting safety programs. These programs consist of driver selection and training, maintenance procedures, and claim procedures, all of which increase system safety.
- System operators may design a service in such a way as to avoid being classified in an expensive rating category. For example, a system may choose not to charge fares so as not to be classified as a for-hire service.



- Social service agencies and other operators can join together to purchase insurance as a cooperative. The Oregon Special Services Association is an organization large enough to have its own insurance broker. Membership by agencies is contingent upon their establishment of a safety program providing guidelines for driver selection and vehicle maintenance. Some of the members have experienced a considerable cost savings. (67). (See reference 119 for a further discussion of group insurance or self insurance plans.)
- State laws classifying transportation services by the standard of care required by the system while in operation, can be amended to state clearly the classification in which human service transportation belongs. This would decrease the uncertainty associated with claims and payments.

V | CONCLUDING COMMENTS

As the information for this report was being gathered it became apparent that what system operators most want to know is which vehicle to buy. For two reasons, however, that question can not be answered fully:

- The vehicles on the market are constantly changing.
- There is a lack of conclusive vehicle performance data.

Nor can that question be answered simply. These vehicles are required to provide a variety of service roles in different geographical areas. The information available with the current state of the art does not permit the designation of one vehicle for all users. Also, vehicle performance is determined not only by careful selection, but by other factors as well, such as maintenance procedures, operating environment, and vehicle handling.

This report presents a description of the types of vehicles available, and an overview of their operating history across the country. It also indicates that proper selection of a vehicle is only one consideration. Among others are the procurement process, which can be complicated and lengthy, preventive maintenance and repair, and financial questions.

It must be remembered that the rapid growth of transportation services requiring small transit vehicles is relatively recent. Thus, the state of the art will advance as system planners and operators gain and share their experiences.



REFERENCES

NOTE: The following references may be obtained from technical or university libraries. PB numbers indicate availability for purchase from the National Technical Information Service; 5285 Port Royal Road, VA; 22161.

1. Abt Associates, TRANSPORTATION NEEDS OF THE HANDICAPPED, Prepared for the U.S. Department of Transportation, Office of Economics and Systems Analysis, Aug. 1969. PB187327.
2. AFL-CIO Appalachian Council, TRANSIT EMPLOYEE TRAINING PROJECT NEEDS ASSESSMENT: SURVEY SUMMARY, Prepared for the U.S. Department of Transportation, Urban Mass Transportation Administration, Oct. 1979.
3. American Association of State Highway and Transportation Officials, Standing Committee on Public Transportation, PUBLIC TRANSPORTATION VEHICLE SPECIFICATIONS QUESTIONNAIRE, summary results of questionnaire sent to 36 states, District of Columbia, and two special service agencies, 1978.
4. American Public Transit Association, TRANSIT FACT BOOK, 1979.
5. Applied Resource Integration, Ltd., and Social Services Research Institute, IMPLEMENTATION GUIDELINES FOR COORDINATED AGENCY TRANSPORTATION SERVICES, Prepared for U.S. Department of Transportation, Urban Mass Transportation Administration, Service and Methods Demonstration Program, and the Department of Health, Education and Welfare, Office of Human Development Services, Apr. 1980.
6. Applied Resource Integration, Ltd., and Social Service Research Institute, PLANNING GUIDELINES FOR COORDINATED AGENCY TRANSPORTATION SERVICES, Prepared for U.S. Department of Transportation, Urban Mass Transportation Administration, Service and Methods Demonstration Program, and the Department of Health, Education and Welfare, Office of Human Development Services, Apr. 1980.
7. Bakr, Mamdouh, and Henry Glueckstein, MAINTENANCE PLANNING FOR SMALL TRANSIT SYSTEMS, in *Transportation Research Record #718: Bus and Rural Transit*, 1979, p. 45-46.
8. Bakr, Mamdouh, and Steven Kretschmer, SCHEDULING OF TRANSIT BUS MAINTENANCE, in *Transportation Engineering Journal*, V. 103 No. TE1, p. 173-181, Jan. 1977.
9. Billheimer, J.W. et al, PARATRANSIT HANDBOOK: A GUIDE TO PARATRANSIT SYSTEM IMPLEMENTATION, V. 1 and 2, Systan, Inc., Prepared for U.S. Department of Transportation, Urban Mass Transportation Administration, Office of Technology Development and Deployment, Office of Bus and Paratransit Technology, Feb. 1979.
10. Bi-State Development Agency, BUS OPERATORS TRAINING MANUAL, St. Louis, MO, [n.d.].
11. Burkhardt, Jon E., COSTS OF RURAL PUBLIC TRANSPORTATION SERVICES, in *Transportation Research Record #696: Rural Public Transportation*, p. 27-31, 1978.
12. Burkhardt, Jon E., PLANNING RURAL PUBLIC TRANSPORTATION SYSTEMS: A SECTION 147 RURAL PUBLIC DEMONSTRATION MANUAL, No. 2 OF 5, Ecosometrics, Prepared for U.S. Department of Transportation, Federal Highway Administration, Urban Mass Transportation Administration, Office of the Secretary, Aug. 1979.
13. Carter, Goble, Roberts, Inc. JOINT HEW-UMTA EVALUATION OF ELDERLY AND HANDICAPPED TRANSPORTATION SERVICES IN REGION IV: PLANNING AND COORDINATION MANUAL, V. 1, Prepared for Department of Health, Education and Welfare, and U.S. Department of Transportation, Urban Mass Transportation Administration, Jan. 1979.
14. Casey, Robert, RECENT EXPERIENCE WITH ACCESSIBLE BUS SERVICES, U.S. Department of Transportation, Transportation Systems Center, Urban Mass Transportation Administration, Service and Methods Demonstrations, Aug. 1979.
15. Casey, Robert, SAN DIEGO WHEELCHAIR ACCESSIBLE BUS STUDY, U.S. Department of Transportation, Transportation Systems Center, Urban Mass Transportation Administration, Service and Methods Demonstration Program, Sept. 1977.
16. Connecticut Transit, THE BUS OPERATOR'S HANDBOOK, Hartford, Connecticut, 1978.
17. Conversation with Chuck Davis, California Department of Transportation, Sacramento, CA, May 7, 1980.
18. Conversation with Connie Olenger, Community Resources Group, Springdale, AR, Mar. 25, 1980.

19. Conversation with Jim Rae, California Department of Transportation, Sacramento, CA, May 7, 1980.
20. Conversation with Kate Hoagland, Iowa Department of Transportation, Des Moines, IA, Nov. 5, 1979.
21. Conversation with Loretta Sharpe, Regional Transportation Program, Portland, ME, Mar. 29, 1980.
22. Conversation with Russ Thatcher, Massachusetts Executive Office of Transportation and Construction, Boston, MA, June 3, 1980.
23. Cook, Allen R., PARATRANSIT RESOURCE GUIDE, University of Oklahoma, School of Civil Engineering and Environmental Sciences, Prepared for U.S. Department of Transportation, Urban Mass Transportation Administration, Office of the Secretary, July 1979, PB80-103237.
24. Cooper, Lawrence, THE USE OF SCHOOL BUSES FOR PUBLIC TRANSPORTATION, North Central Texas Council of Governments, Oct. 1978.
25. Cooper, Tom, Pamela Bloomfield, and Sydwell Flynn, THE LIFT: SPECIAL NEEDS TRANSPORTATION IN PORTLAND, OREGON, Crain and Associates, Prepared for U.S. Department of Transportation, Transportation Systems Center, Urban Mass Transportation Administration, Service and Methods Demonstration Program, June 1978, PB294711.
26. Crain and Associates, TRANSPORTATION PROBLEMS FOR THE HANDICAPPED: TRANSPORTATION SOLUTIONS FOR THE HANDICAPPED, V.4, Prepared for U.S. Department of Transportation, Urban Mass Transportation Administration, Aug. 1976. PB258582.
27. Crain, John, CLEVELAND NEIGHBORHOOD ELDERLY TRANSPORTATION DEMONSTRATION PROJECT, Crain and Associates, Prepared for U.S. Department of Transportation, Transportation Systems Center, Apr. 1977, DOT-TSC-UMTA-77-17, PB2698601.
28. Cutler, Debra A., and Sue F. Knapp, EXECUTIVE SUMMARY: COORDINATING TRANSPORTATION SERVICES FOR THE ELDERLY AND HANDICAPPED, Ecosometrics, Inc., Prepared for U.S. Department of Transportation, Office of Environment and Safety, May 1979. GPO 1979-281-568/96.
29. Davis, Frank, et al., THE SOCIAL SERVICE INSURANCE DILEMMA: PROBLEMS, ANALYSIS AND PROPOSED SOLUTIONS, University of Tennessee Transportation Center, Prepared for U.S. Department of Transportation, Research and Special Programs Administration, Office of University Research, Mar. 1979.
30. Denver Regional Transit District, OPERATING PROCEDURES FOR TDT WHEELCHAIR LIFT; OPERATORS HANDBOOK: HOW TO ASSIST ELDERLY AND HANDICAPPED PERSONS; OPERATING PROCEDURES OF E.E.C. WHEELCHAIR LIFTS, [n.d.].
31. Electric Vehicle Council, ELECTRIC VEHICLE MINI-GUIDE, Washington, DC, 1980.
32. Ewing, Anthony H., ELECTRIC VEHICLES: A PROFILE, in *Electric and Hybrid Vehicle Program - Quarterly Report No. 8 (July-Aug.-Sept.)* p. 4-8, 1979.
33. Florida Department of Transportation, Division of Public Transportation Operations, TRANSIT SYSTEM MAINTENANCE MANUAL, 1979.
34. Flusberg, Martin, et al., SMALL TRANSIT VEHICLE SURVEY, ECI Systems, Inc., Prepared for U.S. Department of Transportation, Transportation Systems Center, June 1975. DOT-TSC-OST-75-17, PB243228.
35. Furniss, Robert E., THE WESTPORT CONNECTICUT INTEGRATED TRANSIT SYSTEM, CACI, INC., Prepared for U.S. Department of Transportation, Transportation Systems Center, Urban Mass Transportation Administration, Service and Methods Demonstration Program, July 1979. UMTA-CT-06-007-796. GPO 1980-634-359/585.
36. Garland, Alice D., and Richard Garrity, STATE ROLES IN RURAL PUBLIC TRANSPORTATION, in *Transportation Research Record #696: Rural Public Transportation*, p. 6-10, 1978.
37. General Motors Corporation, SCHOOL BUS INSPECTION AND MAINTENANCE GUIDE, [n.d.].
38. George Washington University, Rehabilitation Research and Training Center No. 9, ACCESSIBLE BUS TRANSPORTATION — A GUIDE TO ASSISTING THE DISABLED OR ELDERLY PASSENGER, June 1979.
39. Given, Linda G., COUNTY ROLES IN RURAL TRANSPORTATION, National Association of Counties Research Foundation, Prepared for U.S. Department of Transportation, Urban Mass Transportation Administration, June 1977.
40. Goteberg University, Institute for Traffic Safety, SAFETY DURING SPECIAL TRANSPORTATION SERVICE TRIPS: TRANSPORTATION IN VEHICLE DESIGNED FOR THE HANDICAPPED, V.1, Translated by California Department of Transportation, Division of Mass Transportation, for U.S. Department of Transportation, Urban Mass Transportation Administration, Oct. 1974.
41. Grimes, Grovenor, SMALL BUS MARKET, in *Transportation Research Record #696: Rural Public Transportation*, p. 81-82, 1978.
42. Hart, Kathy, MANUAL FOR PLANNING PUBLIC TRANSPORTATION SERVICES IN SMALL URBAN AND RURAL AREAS, Council of Fresno County Governments, and California Department of Transportation, Division of Mass Transportation, 1977.
43. Hayes, Jack, RURAL PUBLIC TRANSPORTATION VEHICLES: A SECTION 147 DEMONSTRATION PROGRAM MANUAL, V. 4, Michigan Department of Transportation, Bureau of Urban and Public Transportation, Prepared for U.S. Department of Transportation, Federal Highway Administration, Urban Mass Transportation Administration, Office of the Secretary, 1979. GPO 1979-281-568/195.
44. Henderson, William, et al., PASSENGER ASSISTANCE TECHNIQUES: A TRAINING MANUAL FOR VEHICLE OPERATORS OF SYSTEMS TRANSPORTING THE ELDERLY AND HANDICAPPED, Transportation Management Associates, 1978.
45. Institute of Public Administration, FINANCING TRANSIT ALTERNATIVES FOR LOCAL GOVERNMENT, Prepared for U.S. Department of Transportation, Urban Mass Transportation Administration, July 1979. GPO 1979-311-586/294.

46. Institute of Public Administration, PLANNING HANDBOOK: TRANSPORTATION SERVICES FOR THE ELDERLY, Prepared for U.S. Department of Health, Education and Welfare, Administration on Aging, Nov. 1975. PB247958.
47. International Taxicab Association, OPERATIONAL GUIDELINES FOR UTILIZATION OF TAXICABS FOR TRANSPORTATION OF HANDICAPPED INDIVIDUALS, [n.d.].
48. Jackson, Arthur, and Douglas McKelvey, INVENTORY OF TRANSPORTATION SERVICES IN PLACES OF LESS THAN 10,000 POPULATION, A&T State University, The Transportation Institute, N.C., Apr. 1978.
49. Jastrzab, Gary, et al., SYNTHESIS OF MANUFACTURER AND STATE AGENCY RESPONSES CONCERNING THE 16(b)(2) VEHICLE PROCUREMENT SPECIFICATIONS, Applications Research Corporation, Prepared for U.S. Department of Transportation, Transportation Systems Center, Sept. 1978.
50. Jet Industries, Inc., VEHICLE DESCRIPTION AND QUOTATION FORM, Mar. 1980.
51. Kefola, H.N., RURAL PUBLIC TRANSPORTATION COORDINATION EFFORTS: A SECTION 147 RURAL PUBLIC DEMONSTRATION MANUAL, V. 3, Applied Resource Integration, Ltd., Prepared for U.S. Department of Transportation, Federal Highway Administration, Office of the Secretary, Aug. 1979. GPO 1979-281-568/196.
52. Kidder, Alice E., USAGE OF REVENUE SHARING FOR PUBLIC TRANSPORTATION IN RURAL AREAS, North Carolina A&T State University, Transportation Institute, Prepared for U.S. Department of Transportation, and U.S. Department of Agriculture, July 1976. GPO 1979-281-568/221.
53. Kidder, Alice E., SOURCES OF NON-FEDERAL SUPPORT FOR PUBLIC TRANSPORTATION PROGRAMS IN NON-URBANIZED AREAS, North Carolina A&T State University, Prepared for U.S. Department of Transportation, Research and Special Programs Administration, Office of University Research, June 1978. PB284410.
54. Knapp, Sue F., COORDINATION OF TRANSPORTATION SERVICES FOR THE ELDERLY AND HANDICAPPED, V. II: A MODEL UNIFORM BILLING AND ACCOUNTING SYSTEM FOR COORDINATED TRANSPORTATION SYSTEMS, Ecosometrics, Prepared for U.S. Department of Transportation, Jan. 1979.
55. Lane, Roy, and Michael Holoszyk, THE ROCHESTER, NEW YORK INTEGRATED TRANSIT DEMONSTRATION, 3 V., Systan, Inc., Prepared for U.S. Department of Transportation, Urban Mass Transportation Administration, Service and Methods Demonstration, Mar. 1979.
56. Loughborough University of Technology, INFRASTRUCTURE, VEHICLE, AND EQUIPMENT DESIGN AND MODIFICATION; in *Mobility for the Elderly and Handicapped: Proceedings of the International Conference on Transit for the Elderly and Handicapped*, Apr. 1978.
57. Loughlin, R. G., EV BUS OPERATION LOOKS GOOD IN NEW YORK, in *Electric Vehicle News*, V. 8, No. 1, p. 4-7, Feb. 1979.
58. Maine Department of Transportation, Bureau of State Planning, DRIVERS AND DISPATCHERS MANUAL FOR PUBLICLY FUNDED PROGRAMS, [n.d.].
59. Maryland Department of Natural Resources, Energy and Coastal Zone Administration, ENERGY MANAGEMENT IN LOCAL GOVERNMENT VEHICLES, Sept. 1978.
60. McCall, Chester, et al., SPECIAL TRANSPORTATION SERVICES FOR THE ELDERLY AND HANDICAPPED IN BATON ROUGE, CACI, INC., Prepared for U.S. Department of Transportation, Urban Mass Transportation Administration, Nov. 1976, PB263904.
61. McGillivray, Robert, et al., RURAL PUBLIC TRANSPORTATION SERVICES AND PERFORMANCES: A SECTION 147 RURAL PUBLIC DEMONSTRATION MANUAL, V.1, Urban Institute, Prepared for U.S. Department of Transportation, Federal Highway Administration, Urban Mass Transportation Administration, Office of the Secretary, Aug. 1979.
62. McKelvey, Douglas J., EVALUATING RURAL PUBLIC TRANSPORTATION, North Carolina A&T State University, Transportation Institute, Feb. 1977.
63. McKelvey, Douglas, and Richard S. Watt, INNOVATIVE APPROACHES TO RURAL TRANSPORTATION, in *Transportation Research Record #661: Public Transportation in Rural and Suburban Areas*, p. 1-5, 1978.
64. Massachusetts Executive Office of Communities and Development, Division of Community Services, ENERGY MANAGEMENT IN MUNICIPAL VEHICLES, Mar. 1977.
65. Mercier, Cletus, HANDBOOK FOR PREPARATION OF CONTRACT DOCUMENTS, Iowa State University, College of Engineering, Prepared for Iowa Department of Transportation, Public Transit Division, 1979.
66. Michigan Department of Transportation, Bureau of Urban and Public Transportation, MICHIGAN SMALL BUS PROGRAM MANAGEMENT HANDBOOK, two editions: June 1978 and Sept. 1979.
67. Moore, Dennis H., FUNDING INSURANCE AND REGULATION DEVELOPMENTS IN OREGON, in *Transportation Research Record #696: Rural Public Transportation*, p. 41-43, 1978.
68. Motor Vehicle Manufacturers Association, TRUCK AND BUS SIZES AND WEIGHTS, 1980.
69. Motor Vehicle Manufacturers Association, VEHICLE INSPECTION HANDBOOK: PASSENGER CARS, AND VEHICLE INSPECTION HANDBOOK. TRUCK/BUS/SCHOOL BUS, 1979.
70. National Council for the Transportation Disadvantaged and the U.S. Department of Agriculture, Farmers Home Administration, RURAL RIDES: A PRACTICAL HANDBOOK FOR STARTING AND OPERATING A RURAL PUBLIC TRANSPORTATION SYSTEM, Nov. 1979.
71. Newmann, Lance A., James A. Wojno, and Richard D. Juster, INTEGRATED DIAL-A-RIDE AND FIXED ROUTE TRANSIT IN ANN ARBOR, MICHIGAN, Cambridge Systematics, Inc., and Multisystems, Inc., Prepared for U.S. Department of Transportation, Transportation Systems Center, Urban Mass Transportation Administration, Service and Methods Demonstration, Mar. 1977, DOT-TSC-UMTA-77-7. PB267941.
72. North Carolina A&T State University, Transportation Institute, PROCEEDINGS OF THE FIRST NATIONAL CONFERENCE ON RURAL PUBLIC TRANSPORTATION, Prepared for U.S. Department of Transportation, Office of University Research, Technology Sharing Program, Oct. 1976.

73. OATS, Inc., DRIVERS HANDBOOK, Columbia, MO, July 1979.
74. Paul, Grant, and Robert Casey, ATLANTA WHEELCHAIR ACCESSIBLE BUS STUDY, U.S. Department of Transportation, Transportation Systems Center, Aug. 1978, DOT-TSC-UMTA-78-36. PB285938.
75. Peel, Herbert, et al., TESTING AND EVALUATION OF COMMERCIALY AVAILABLE WHEELCHAIR RESTRAINT SYSTEMS, Southwest Research Institute, Prepared for U.S. Veterans Administration, Prosthetics Center, Sept. 1978.
76. Pratt Institute, URBAN DESIGN AND USAGE FACTORS OF PARATRANSIT VEHICLES AND FACILITIES, Prepared for U.S. Department of Transportation, Urban Mass Transportation Administration, Apr. 1976.
77. Public Technology, Inc., DIAL-A-RIDE VEHICLES, *SMD Briefs: Rochester, N. Y. #4*, Prepared for Urban Consortium, Transportation Task Force, Apr. 1979.
78. Public Technology, Inc., ELDERLY AND HANDICAPPED TRANSPORTATION: EIGHT CASE STUDIES, Prepared for U.S. Department of Transportation, Urban Mass Transportation Administration, Service and Methods Demonstration, Sept. 1979.
79. Public Technology, Inc., ELDERLY AND HANDICAPPED TRANSPORTATION: INFORMATION SOURCEBOOK, Prepared for U.S. Department of Transportation, Urban Mass Transportation Administration, Sept. 1979.
80. Public Technology, Inc., ELDERLY AND HANDICAPPED TRANSPORTATION: LOCAL GOVERNMENT APPROACHES, Prepared for U.S. Department of Transportation, Urban Mass Transportation Administration, Mar. 1979. PB297289.
81. Revis, Joseph, COORDINATION, COSTS, AND CONTRACTING FOR TRANSPORTATION SERVICES, in *Transportation Research Record #696: Rural Public Transportation*, p. 46-55, 1978.
82. Revis, Joseph, JOINT FUNDING AND DEPRECIATION in *Transportation Research Record #696: Rural Public Transportation*, p. 43-46, 1978.
83. Rosenbloom, Sandra, et al., COST EFFECTIVENESS MEASURES FOR TRANSPORTATION SERVICES FOR THE ELDERLY AND HANDICAPPED, University of Texas at Austin, Council for Advanced Transportation Studies, Prepared for U.S. Department of Transportation, Urban Mass Transportation Administration, Oct. 1979.
84. RRC International, Inc., SMALL TRANSIT BUS REQUIREMENTS, Six Volumes, Prepared for U.S. Department of Transportation, Urban Mass Transportation Administration, 1977. UMTA-IT-06-00-74-77-1 through 6.
85. Ryden, Tom, FUNCTIONAL SPECIFICATIONS FOR SMALL VEHICLES FOR USE BY THE HANDICAPPED AND ELDERLY, North Central Texas Council of Governments, Sept. 1977.
86. Sacramento Regional Planning Commission, and Paratransit, Inc., COST REDUCTIONS FOR PARATRANSIT OPERATIONS THROUGH JOINT PURCHASING AND CENTRALIZED MAINTENANCE, Sacramento, CA, Apr. 1980.
87. Samuels, Robert E., TECHNOLOGY OF THE PARATRANSIT VEHICLE, in *Transportation Research Board, Special Report #186; Paratransit: 1979*, p. 63-67, 1979.
88. Sanders, Mark S., A REQUIREMENTS ANALYSIS DOCUMENT FOR TRANSIT VEHICLE WHEELCHAIR LIFT DEVICES, Prepared for U.S. Department of Transportation, Urban Mass Transportation Administration, June 1978.
89. Schimpler Corradino Associates, FLORIDA TRANSIT MANUAL FOR SMALL URBAN AND RURAL AREAS, Prepared for Florida Department of Transportation, June 1978.
90. Schneider, Lawrence, DYNAMIC TESTING OF RESTRAINT SYSTEMS AND TIE-DOWNS FOR USE WITH VEHICLE OCCUPANTS SEATED IN POWERED VEHICLES, Interim Report, University of Michigan, Highway Safety Research Institute, Prepared for Massachusetts Rehabilitation Commission, Aug. 1980.
91. Schneider, Lawrence, and John Melvin, IMPACT TESTING OF RESTRAINT DEVICES USED WITH HANDICAPPED CHILDREN IN BUS SEATS AND WHEELCHAIRS, University of Michigan, Highway Safety Research Institute, Prepared for Wisconsin Department of Public Instruction, Nov. 1978.
92. Schneider, Lawrence, and John Melvin, SLED TEST EVALUATION OF A WHEELCHAIR RESTRAINT SYSTEM FOR USE BY HANDICAPPED DRIVERS, University of Michigan, Highway Safety Research Institute, Prepared for University of Michigan, Rehabilitation Engineering Center, Nov. 1978.
93. Schneider, Phillip, and David Norton, LOW LIFE CYCLE COST: PARATRANSIT VEHICLE DESIGN STUDY, Dutcher Industries, Prepared for U.S. Department of Transportation, Urban Mass Transportation Agency, Office of Technology Development and Deployment, Aug. 1978.
94. Sigafos, Roland, SMALL BUS DESIGN, Florida Department of Transportation, Division of Mass Transit Operations, Prepared for U.S. Department of Transportation, Urban Mass Transit Administration, [n.d.].
95. Stewart, Carl F., and Herbert G. Reinl, STUDENT WHEELCHAIR TRANSPORTATION: LOADING AND SECUREMENT, California Department of Transportation, Division of Mass Transportation, Aug. 1974.
96. Stewart, Carl F., and Herert G. Reinl, WHEELCHAIR SECUREMENT ON BUS AND PARATRANSIT VEHICLES, draft in progress, California Department of Transportation, Division of Mass Transportation, Prepared for U.S. Department of Transportation, Urban Mass Transportation Administration, Feb. 1980.
97. Systems Architects, Inc., BUS LIFT STATE-OF-THE-ART REVIEW, Jan. 1980.
98. SURFACE TRANSPORTATION ASSISTANCE ACT OF 1978, 49 U.S.C.
99. Teixeira, Diego, Frank Varker, and Robert Bonlin, ACCESSIBLE BUS SERVICE IN ST. LOUIS, Applied Resource Integration, Ltd., Prepared for U.S. Department of Transportation, Urban Mass Transportation, Service and Methods Demonstration Program, Feb. 1980.
100. Transportation Management Associates, REPORT ON THE FIRST SIX MONTHS OF TRAINING IN PASSENGER ASSISTANCE TECHNIQUES, Prepared for Texas Department of Highways and Public Administration, 1979.

101. URBAN MASS TRANSPORTATION ACT OF 1964, AS AMENDED, 49 U.S.C.
102. University of Michigan, and Michigan Department of Transportation, Bureau of Urban and Public Transportation, EQUIPMENT AND MAINTENANCE REQUIREMENTS FOR LIGHT-WEIGHT ACCESSIBLE BUS OPERATIONS, Prepared for U.S. Department of Transportation, Transportation Systems Center, Urban Mass Transportation Administration, May 1980. DOT-TSC-1604.
103. U.S. Department of Energy, Assistant Secretary for Conservation and Solar Applications, Division of Transportation Energy Conservation, DRIVER ENERGY CONSERVATION AWARENESS TRAINING (DECAT): HANDBOOK, Jan. 1980.
104. U.S. Environmental Protection Agency and the U.S. Department of Energy, GAS MILEAGE GUIDE 1980, 1980.
105. U.S. General Accounting Office, HINDRANCES TO COORDINATING TRANSPORTATION OF PEOPLE PARTICIPATING IN FEDERALLY FUNDED GRANT PROGRAMS, V. 1-2, Oct. 1977.
106. U.S. Department of Health, Education and Welfare, Office of Human Development Services, HDS TRANSPORTATION INITIATIVE in *HDS Fact Sheet*, July 1979.
107. U.S. Department of Health, Education and Welfare, Office of Human Development Services, NEW INSURANCE PROGRAMS FOR HUMAN SERVICE PROVIDERS: TECHNICAL ADVISORY, No. 1, Aug. 1979.
108. U.S. Department of Health, Education and Welfare, Office of Human Development Services, Administration for Public Services, NATIONAL WORK PLAN TO RESOLVE THE TRANSPORTATION INSURANCE PROBLEMS, Aug. 1979.
109. U.S. Department of Health, Education and Welfare, Office of Human Development Services, Administration for Public Services, PROCEEDINGS: WHITE HOUSE WORKSHOP ON TRANSPORTATION INSURANCE, Jan. 1979.
110. U.S. Department of Labor, Labor Management Administration, Division of Employee Protection, RURAL TRANSPORTATION EMPLOYEE PROTECTION GUIDEBOOK, Sept. 1979.
111. U.S. Department of Transportation, Federal Highway Administration, Office of the Secretary, AN OVERVIEW OF TRANSPORTATION INSURANCE PROBLEMS IN RURAL AREAS: A REPORT TO CONGRESS IN RESPONSE TO SECTION 313(a) OF THE SURFACE TRANSPORTATION ASSISTANCE ACT OF 1978, Apr. 1980.
112. U.S. Department of Transportation, Transportation Systems Center, Office of Technology Sharing, PARATRANSIT: STATE-OF-THE-ART OVERVIEW, draft in progress, May 1980.
113. U.S. Department of Transportation, Transportation Systems Center, Office of Technology Sharing, MINI-BUS PROFILE, 1975.
114. U.S. Department of Transportation, Transportation Systems Center, Office of Technology Sharing, TRANSPORTATION FOR THE ELDERLY AND HANDICAPPED: PROGRAMS AND PROBLEMS, Nov. 1978. GPO 1979-626-077/513.
115. U.S. Department of Transportation, Urban Mass Transportation Administration, EXTERNAL OPERATING MANUAL: SECTION C: THIRD-PARTY CONTRACT ADMINISTRATION, UMTA 1000.2, Chg. 2, Mar. 1974.
116. U.S. Department of Transportation, Transportation Systems Center, Urban Mass Transportation Administration, Office of Service and Methods Demonstration Program, SMALL CITY TRANSIT, May 1976. UMTA-MA-06-0049-76-1 through 15.
117. U.S. Department of Transportation, Urban Mass Transportation Administration, and the Transportation Research Board, WORKSHOP ON SMALL BUSES: PROCEEDINGS, Apr. 1978.
118. U.S. Veterans Administration, Prosthetics Center, VA STANDARD DESIGN AND TEST CRITERIA FOR SAFETY AND QUALITY OF AUTOMATIC WHEELCHAIR LIFT SYSTEMS FOR PASSENGER MOTOR VEHICLES, June 1977.
119. Warren, McVeigh, and Griffin, VEHICLE INSURANCE STUDY, Prepared for the Wisconsin Department of Transportation, Bureau of Transit, May 1980.
120. Young, David, COME BACK FOR THE SHORTY BUS? in *Mass Transit*, Volume V. No. 61, p. 86-88, June 1979.

GLOSSARY

accessibility

Freedom of a transit system from barriers preventing travellers from using that system.

bid

Statement of what vehicle a supplier will sell to the buyer and at what price.

body on chassis

Marriage of a light truck chassis and a body.

bond

Provides collateral against a bidder's failure to perform.

Caltrans

California Department of Transportation.

demand-responsive service

Characterized by flexible routing and scheduling to provide shared occupancy on demand, often with door-to-door service. Often provided for people whose mobility is limited.

DOT

United States Department of Transportation.

electrical vehicle (EV)

Vehicle with a conventional chassis in which the internal combustion engine has been replaced with an electric motor and a propulsion system powered by lead acid batteries.

feeder service

Provides transportation to and from a regular transit route.

FHWA

Federal Highway Administration.

fixed-route service

Transit service with regular routes and schedules.

life-cycle costs

All costs associated with a vehicle's useful life (i.e., acquisition, operating, and maintenance costs).

lift

Device which lifts a wheelchair user from ground level to the level of the vehicle floor so that the user can wheel onto the vehicle.

modified van

Standard van with some body and/or chassis modification.

paratransit

Flexible transportation service, operated publicly or privately. Typically, a small-scale operation using small transit vehicles.

pre-arranged ride-sharing service

Includes van pooling and subscription buses which operate mainly during peak time to provide commuters who have predetermined work schedules the opportunity to share vehicles.

preventive maintenance

Maintenance program based on regularly scheduled inspections rather than on emergency repairs necessitated by vehicle breakdowns.

seat kilometer (or seat mile)

Unit representing the number of kilometers (or miles) travelled by a vehicle multiplied by the number of seats in the vehicle.

shuttle service

Service which operates along heavily travelled corridors such as those in urban centers, large commercial mall areas, and airports.

small bus

Bus whose chassis and body are designed as an integral unit durable in transit service.

small transit vehicle

Vehicle smaller than the 40-foot standard transit bus.

standard van

Type of van available from automotive manufacturers.

technical specifications

That part of the contract which determines the actual components, construction, and performance requirements of the vehicles. Specifications can be phases or drawings.

cost per vehicle kilometer (or vehicle mile)

Equals the total system cost divided by the sum of the kilometers (or miles) travelled by each vehicle in the system.

wheelchair securement

Device which holds a wheelchair, and sometimes its occupant, in place within a vehicle. Also known as a wheelchair restraint or tiedown.

APPENDIX A
MANUFACTURERS OF SMALL TRANSIT VEHICLES

Modified Vans

Advanced Mobility 15912 Arminta St. Van Nuys, CA 91406 213-782-0200	HP Bus Corporation of America P.O. Box 28 Faulkner St. N. Billerica, MA 01862 617-452-2777
Braun Corporation 1014 S. Monticello Winamac, IN 46996 219-946-6157	Medicab, Inc. 68 Runyon Ave. Yonkers, NY 10710 212-798-5380
Broughman Industries, Inc. 14320 Ramona Ave. Chino, CA 91710 714-597-1893	Midwest Handicap Equipment 510 N. 5th St. St. Charles, MO 63301 314-724-0400
Bud Industries, Inc. 100 Pulaski St. W. Warwick, RI 02893 401-822-2352	Mobility Dynamics, Inc. 21029 Itasca Ave. Chatsworth, CA 91311 213-998-1026
Drive Master Corporation 16 Andrews Dr. W. Patterson, NJ 07424 201-785-2204	National Coach Corporation 130 W. Victoria Gardena, CA 90248 213-538-3122
General Mobility Co. 265 Route 10 E. Hanover, NJ 07936 201-887-7500	National Custom Van 1051 Saw Mill River Rd. Yonkers, NY 10710 914-423-3331
Gresham Driving Aids, Inc. P.O. Box 405 30800 Wixom Rd. Wixom, MI 48096 313-624-1533	Quality Coach Route 309 Montgomeryville, PA 18936 215-643-2211
Hames Bus Sales 5602 E. Belmont Fresno, CA 93727 209-251-8332	R.J. Mobility Systems 715 S. 5th Ave. Maywood, IL 60153 312-344-2705

Skillcraft Industries
1270 Ogden Rd.
Venice, FL 33595
813-488-1501

Sportscoach Corp.
P.O. Box 1945
Elkhart, IN 46515
212-262-3471

Target Industries
55 Newbury Rd.
Warehouse Point, CT 06088
203-627-9329

Universal Coach Corp.
P.O. Box 366
Nesconset, NY 11767
516-587-6448

Wheels for the Handicapped
P.O. Box 115
N. Chelmsford, MA 01863
617-256-3489

Wide One Corporation
3051 E. La Palma Ave.
Anaheim, CA 92806
714-630-7933

Wolf Coach
200 Bartlett St.
Northboro, MA 01532
617-393-6038

Body On Chassis

Atlantic Research Corporation
5400 B. Eisenhower Ave.
Alexandria, VA 22304
703-642-4000

Carpenter Body Works, Inc.
W. Main St.
Mitchell, IN 47446
812-849-3131

Coach and Equipment Sales Corporation
P.O. Box 36
Penn Yan, NY 14527
315-536-2321

Collins Industries, Inc.
P.O. Box 58
Hutchinson, KS 67501
316-663-4441

Coons Manufacturing, Inc.
2300 W. Fourth St.
Box 489
Oswego, KS 67356
316-795-2191

LTP Fixette
151 E. Walnut St.
Nappanee, IN 46550
219-773-7761

Microbus Corporation
12420 Bloomfield Ave.
Santa Fe Springs, CA 90670
213-923-3221

National Coach Corp.
130 W. Victoria
Gardena, CA 90248
213-538-3122

Para Industries, Ltd.
74 Jamie St.
Nepean, ON
Canada K2E 6T6
613-226-5506

Quality Coach
Route 309
Montgomeryville, PA 18936
215-643-2211

Sportscoach
P.O. Box 1945
Elkhart, IN 46515
219-262-3471

Superior
1200 E. Kibby St.
Lima, OH 45802
419-227-7777

Thomas Built Buses, Inc.
1408 Courtesy Rd.
P.O. Box 2450
High Point, NC 27261
919-889-4871

Universal Coach
P.O. Box 366
Neconset, NY 11767
516-587-6448

Ward Industries, Inc.
P.O. Box 849
Conway, AR 72032
501-327-7761

Wayne Corporation
Industries Rd.
P.O. Box 1447
Richmond, VA 47374
317-962-7511

Small Buses

Bluebird Body Company
P.O. Box 937
Fort Valley, GA 31030
912-825-2021

Chance Manufacturing Company, Inc.
1103 Ross Ave.
Dallas, TX 75202
214-742-3802

Hausman Bus Sales
505 N. Lake Shore Dr.
Suite 6106
Chicago, IL 60611
312-321-1004

Skillcraft Industries
1270 Ogden Rd.
Venice, FL 33595
813-488-1501

Steyr-Daimler Puch AG
Transit Sales Corporation
1103 Ross Ave.
Dallas, TX 75202
214-742-3802

APPENDIX B
MANUFACTURERS OF WHEELCHAIR LIFTS AND RAMPS
AND WHEELCHAIR SECUREMENTS

LIFTS

Platform Lifts

ABC Enterprises, Inc.
8907 Mentor Ave.
Mentor, OH 44060
216-255-5211

American Medical Research Laboratories
2456 Central Ave.
St. Petersburg, FL 33712
813-823-5662

Braun Corporation
1014 S. Monticello
Winamac, IN 46996
219-946-6157

Bud Industries, Inc.
100 W. Pulaski St.
West Warwick, RI 02893
401-822-2352

Coach & Equipment Sales Corporation
P.O. Box 36
Penn Yan, NY 14527
315-536-2321

Collins Industries
P.O. Box 58
Hutchinson, KS 67501
316-663-4441

Crow River Industries, Inc.
1415 E. Wayzata Blvd.
Wayzata, MN 55391
612-475-2786

Double D Industries
341 North Dr.
St. Charles, MO 63301
314-946-3020

Drive Master Corporation
16 Andrews Dr.
West Patterson, NJ 07425
201-785-2204

Electro Van Lift, Inc.
140 Concord St.
St. Paul, MN 55107
612-298-0721

Handicaps, Inc.
4335 S. Santa Fe Dr.
Englewood, CO 80110
303-781-2062

Mac's Lift Gate, Inc.
2127 South St.
Long Beach, CA 90805
213-634-5962

Mobility Dynamics, Inc.
21029 Itasca Ave.
Chatsworth, CA 91311
213-998-1026

P & Q Lifts
4457 63rd Circle North
Pinellas Park, FL 33565
813-522-9024

Para Industries, Ltd.
74 Jamie St.
Nepean, ON
Canada K2E 6T6
613-226-5506

REB Manufacturing, Inc.
Box 276
Route 2
Carey, OH 43316
419-396-7651

Ricon Corporation
11684 Tuxford
Sun Valley, CA 91352
213-994-7722

RJ Mobility Systems
715 S. 5th Ave.
Maywood, IL 60153
312-344-2705

Scott, Fred & Sons
444 W. Rand Rd.
Des Plaines, IL 60016
312-297-1603

Skillcraft Industries
1270 Ogden Rd.
Venice, FL 33595
813-488-1501

Step Lifts

Environmental Equipment Corporation
970 East 14th St.
San Leandro, CA 94577
415-568-1422

GM Truck and Coach
660 South Blvd. E.
Pontiac, MI 48053
313-857-4054

Lift-U-Inc.
5th Floor
Third and Lenora Bldg.
Seattle, WA 98121
206-624-5556

Target Industries
55 Newbury Rd.
Warehouse Point, CT 06088
203-627-9329

Total Mobility Systems and Designs, Inc.
4060 Stewart Rd.
Eugene, OR 97402
503-686-9706

Translift Equipment, Ltd.
#5
4826 11 St., N.E.
Calgary, AB T2E 2W7 Canada
403-276-7818

Transportation Design and Technology (TDT)
9345 Cabot Dr.
San Diego, CA 92126
714-566-8940

Vapor Corporation
Transportation Systems Division
6420 W. Howard St.
Chicago, IL 60648
312-631-9200

RAMPS

Collins Industries
P.O. Box 58
Hutchinson, KS 67501
316-663-4441

Handi-Ramp, Inc.
1414 Armour Blvd.
Mundelein, IL 60060
312-566-5861

Medicab, Inc.
68 Runyon Ave.
Yonkers, NY 10710
212-798-5380

WHEELCHAIR SECUREMENTS

The manufacturers listed below are those who sell their devices as individual products. Manufacturers who only sell their devices as part of a vehicle package are not included. This list is not complete. We regret any omissions.

There is a great deal of variation among wheelchair securement devices. The devices are not only made of different materials, they also vary in their method of attachment to the vehicle and to the wheelchair. Therefore, the devices are grouped into the broad categories listed below. Although the photos of each type are of particular devices available on the market, they are used here merely to serve as examples and to illustrate the written descriptions.

- BELTS** Belts used for securement devices are similar to car seat-belts. As securements, they are often attached to the vehicle by rings or tracks on the floor, or they are bolted directly to the floor. They are usually attached to the wheelchair at from one to four points on the chair frame. Some wrap around the chair (and passenger). Belts are often used to restrain the passenger as well as to secure the wheelchair. These belts are attached to the chair or vehicle, or both.
- WHEEL RIM HOLDER** This device consists of rods or pins placed between U-shaped brackets or clamps. A securement system may include one or two rim holders. Some devices are semi- or fully automatic, which reduces the physical effort needed by the passenger to get into and out of the holder.
- T-BAR** A T-bar is a horizontal bar placed between the wheels. Each end of the bar grabs onto the lower wheelchair frame, and a vertical rod or screw in the center of the bar attaches the bar to the floor.
- LATERAL GRAB BAR** This device is a lateral arm which lies alongside the large wheels. It is often attached to the vehicle behind the wheels and grabs onto the front of a large wheel or onto the chair frame.
- FRAME LOCK** A frame lock is a permanent wheelchair attachment which locks onto a device located in the vehicle.
- OTHER** Devices were placed in this category if they could not be included in the other categories. Also, devices were placed here if there was insufficient information on their design.

Manufacturer	Belts	Wheel Rim Holders	T-Bar	Lateral Grab Bar	Frame Lock	Other
ABC Enterprises 8907 Mentor Ave. Mentor, OH 44060 216-255-5211		X				
Advanced Mobility 15912 Arminta St. Van Nuys, CA 91406 213-782-0200	X		X			
Aeroquip Corporation Industrial Division 1225 W. Main St. Van Wert, OH 45891 419-238-1190	X					
American Seating Transportation Seating Division 901 Broadway N.W. Grand Rapids, MI 49504 616-456-0600		X				
Atlantic Research Corporation 5400 B. Eisenhower Ave. Alexandria, VA 22304 703-642-4000						X
Braun Corporation 1014 S. Monticello Winamac, IN 46996 219-946-6157	X	X				X
Bud Industries 1000 Pulaski St. West Warwick, RI 02893 401-822-2352		X	X			X

Manufacturer	Belts	Wheel Rim Holders	T-Bar	Lateral Grab Bar	Frame Lock	Other
Coach and Car Equipment 1951 Arthur Ave. Elk Grove Village, IL 60007 312-437-5760		X				
Collins Industries, Inc. P.O. Box 58 Hutchinson, KS 67501 316-663-4441		X				
Creative Controls 1352 Section K Combermere Troy, MI 48084 313-585-0985					X	
Crow River Industries, Inc. 1415 E. Wayzata Blvd. Wayzata, MN 55391 612-475-2786	X					
Double D Industries 341 North Dr. St. Charles, MO 63301 314-946-3020						X
Dynamic Mobilities, Inc. 2068 Helena St. Madison, WI 53704 608-249-1234					X	
Electro Van Lift, Inc. 140 Concord St. St. Paul, MN 55107 612-298-0721						X
Falcon Equipment Specialties 57 Tunxis St. Windsor, CT 06095 203-688-7596		X				X

Manufacturer	Belts	Wheel Rim Holders	T-Bar	Lateral Grab Bar	Frame Lock	Other
Gresham Driving Aids P.O. Box 405 30800 Wixom Rd. Wixom, MI 48096 313-624-1533			X			
Handicaps, Inc. 4335 S. Santa Fe Dr. Englewood, CO 30110 303-781-2062	X					
Handi-Ramp 1414 Armour Blvd. Mundelein, IL 60060 312-566-5861	X	X				
Medicab, Inc. 68 Runyon Ave. Yonkers, NY 10710 212-798-5380			X			
Midwest Handicap Equipment Co. 510 North 5th St. St. Charles, MO 63301 314-724-0400	X		X			
Mobility Dynamics 21029 Itasca Ave. Chatsworth, CA 91311 213-998-1026						X
Olson, Charles and Sons 677 Transfer Rd. St. Paul, MN 55114 612-641-3900				X		

Manufacturer	Belts	Wheel Rim Holders	T-Bar	Lateral Grab Bar	Frame Lock	Other
Para Industries 74 Jamie St. Nepean, ON Canada K2E 6T6 613-226-5506	X					X
R. J. Mobility Systems 715 South 5th Ave. Maywood, IL 60153 312-344-2705						X
Scott, Fred and Sons 1444 W. Rand Rd. Des Plaines, IL 60016 312-297-1603			X			
Target Industries 55 Newbury Rd. Warehouse Point, CT 06088 203-627-9329						X

APPENDIX C
MAJOR FEDERAL FUNDING SOURCES

**PRIMARY U.S. DEPARTMENT OF TRANSPORTATION
URBAN MASS TRANSPORTATION ADMINISTRATION FUNDING OPTIONS**

SOURCES	PURPOSE	FUNDING LIMITATIONS	WHO CAN APPLY	REQUIREMENTS	APPLICATION PROCESS
Discretionary Capital Assistance Grants (UMTA Section 3)	To purchase, construct, or finance land, vehicles, facilities, and equipment	80% federal, 20% local; state matching basis; most committed to conventional transit programs; UMTA encourages Sec. 5 for para-transit	State or local public agencies and operators	Agency authorization; assurance of non-federal share; 3-C planning process; public hearing; Sec. 13(c) certification; civil rights compliance; include Transportation Improvement Program (TIP) ¹	Operator submits pre-application to UMTA Office of Capital Assistance for review, then formal Sec. 3 application
Grants for Urbanized Areas (UMTA Section 5)	To assist capital-related and operating expenses	Capital: 80% federal, 20% local and state; operating: 50% federal, 50% local and state, excluding fare revenue; restricted to areas with populations over 50,000	Public and private agencies	Same as above, plus half fares for elderly and handicapped, maintenance of effort, uniform accounting	Operator submits grant application to UMTA Office of Capital Assistance
Formula Grants for Non-Urbanized Areas (UMTA Section 18)	To assist capital-related and operating expenses of rural passenger transportation systems	Capital and administrative: 80% federal, 20% local and state; operating: 50% federal, 50% local and state	State, local, public and non-profit agencies and operators; restricted to areas with populations of less than 50,000	No maintenance-of-effort requirement, but encourages continuation of existing funding; identified in TIP; individual state requirements apply	Operator submits grant application to state-designated administering agency
Transit Demonstration Program (UMTA Section 6)	To develop, test, and promote new facilities, techniques, equipment, or methods for research and development	Short-term (1-3 year) capital and operating funds available; local financial support not required, but will improve project's funding potential; cannot cover existing or conventional transit operations.	Public and private agencies	Innovative or experimental project, unique in location or application; project monitoring & evaluation to document results; Sec. 13(c) requirement	Informally determine UMTA's interest in proposed project; obtain grant application package, submit to UMTA Office of Research and Development
Planning Assistance Program (UMTA Section 9)	To develop coordinated local transit plans and programs	80% federal, 20% local and state; distributed by formula to states	State or local public agencies	3(c) planning	Federal to local (or state) grantees
UMTA Section 16(b)(1) UMTA Section 16(b)(2)	To provide capital assistance for special transit service where existing or proposed public or private services are not adequate or appropriate	80% federal, 20% local; discretionary grants distributed federal to local 80% federal, 20% local; formula grants distributed to state to local	Public agencies Nonprofit and private organizations	Identified in TIP urbanized areas; in TDP in non-urbanized areas; must meet special needs of elderly and handicapped	Submit application to Metropolitan Planning Organization (MPO); MPO submits TIP to state and UMTA Submit application to state; state submits consolidated application to UMTA for selected applicants

¹Determine compliance with most requirements during the TIP approval process.

Source: Adapted from Reference 9.

MAJOR FEDERAL FUNDING SOURCES FOR TARGET MARKET PARATRANSIT SERVICES

Department Statute	Description	Provides Transport For	Provider Eligibility/ Administering Agency	Target Market	User Eligibility Restrictions	Area Coverage	Capital Purchase	Comments	Funding Limitations
<i>Department of Transportation (DOT)</i> Urban Mass Transportation Assistance Act of 1964, as amended Title III, Section 16(b)(1) Section 16(b)(2)	Public sector capital grants. Social service capital grants.	Those with special transportation needs	Public agencies, public bodies or states Private and nonprofit agencies	Elderly and handicapped	Those unable to use regular public transportation; UMTA elderly & handicapped criteria apply	Urban areas with populations over 5,000	Allowed	Intended for areas where existing or proposed public and private services are not adequate.	80% federal; 20% non-federal match; federal to local discretionary grants. 80% federal; 20% non-federal match; federal to state to local.
Federal Highway Act of 1973 Section 147	Rural highway demonstrations	Public in rural and small urban areas	Public or nonprofit public purpose agencies in communities with populations less than 5,000	Elderly and handicapped	FHWA elderly & handicapped criteria	Towns with populations of less than 5,000 people	Allowed; operating costs limited to one-third of total grant	Projects demonstrating innovative service types, coordination, funding, management, etc. (Rolling stock must include one vehicle to accommodate wheelchair users.)	Up to 100% federal grants.
<i>Department of Housing and Urban Development (HUD)</i> Housing & Community Development Act of 1974 Title I	Community development program for social services	General population for special projects	General unit of local government; urban community with populations greater than 50,000	Low-income elderly & handicapped	Community decision	Community	Allowed	Funds may be used to support capital, operating, or administrative transportation costs, but must be integral part of total community development program.	100% federal grants and contracts possible; no local contribution requirements.
<i>Department of Health and Human Services (HHS)</i> Social Security Act of 1935, as amended Title XIX	Medicaid; Medical assistance programs	Medical purposes	Single state agency (usually Dept. of Welfare)	Low-income, elderly, blind, disabled	SSI eligibility criteria or more restrictive criteria at state option	State	Prohibited	Federal financial reimbursement available for transportation of ambulance, taxicab, privately-owned vehicle, or other "appropriate" means. Include means of providing transportation to medical services in state plan.	Federal aid ranges from 50% to 83%; state % match varies

Department Statute	Description	Provides Transport For	Provider Eligibility/ Administering Agency	Target Market	User Eligibility Restrictions	Area Coverage	Capital Purchase	Comments	Funding Limitations
<i>Department of Health and Human Services (HHS)</i> Social Security Act of 1935, as amended Title XX	Social services for individuals and families	Defined services, medical services and essential shopping	State Title XX agency	People with low-incomes, elderly, the blind, disabled, and children	1) Income maintenance status; 2) Income status; 3) Without regard to income.	State	Allowed	Replaces funds formerly administered through Title VI & VIA. Must be included in annual state plan.	90% federal for planning; 10% non-federal match. 75% federal for services; 25% non-federal match. Formula grants to states not less than FY73 or FY74 level.
Older Americans Act of 1965, as amended Title III, Part C	Elderly nutrition	Nutrition sites	Any public or private agency. Single recipient in project area	Elderly	Individuals at least aged 60+ and spouses, "limited mobility" status	Urban or rural. State establishes criteria	Allowed; will not fund transportation (supportive service)	Purchase of vehicles and special equipment, client and staff reimbursement and services allowed.	90% federal; 10% in cash or in kind non-federal match.
Title III, Section 308	Model projects	Model projects to expand social services	State agency on aging; designates public or non-profit organization as the Area Agency on Aging.	Those who are physically or mentally impaired; elderly	None	Varies	Prohibited	Agency on aging encourages capital purchase by coordinating with DOT funds	75% federal for state planning, administration and services not in plan. 90% federal for services in area plans. State/local cash or in-kind match. Maintain level of funding requirements.
Title III All sections except 308	Programs on Aging, area planning and social services	Access to social services		Elderly	Department of Commerce criteria	Planning Service Areas (PSA)	Discouraged	Client and staff transportation reimbursement and purchase of service contracts. Include in 3-year state plan with annual updates.	
Public Health Service Act of 1944, as amended	Comprehensive health services	Broad health services	State health and/or mental health authorities	General population with health needs, especially "high-risk" groups	None	Community	Allowed with state approval	Must have state plan; formula matching depends on state's per capita income.	Federal funds matched by state; formula varies by each state's per capita income.
Rehabilitation Act of 1973, as amended Title I	Vocational rehabilitation facilities and services	Any vocational rehabilitation services (including medical)	State vocational rehabilitation agencies and public or non-profit organizations (e.g., Goodwill)	Vocational rehabilitation clients	Unemployed, handicapped but employable	State	Allowed but not encouraged	Transportation items must be included in 3-year state plan, with annual updates. Purchase of special equipment, services and staff and client reimbursement allowed.	80% federal, 20% non-federal match. Formula grants to states. Federal allotments reduced if non-federal funds less than FY72.

Department Statute	Description	Provides Transport For	Provider Eligibility/ Administering Agency	Target Market	User Eligibility Restrictions	Area Coverage	Capital Purchase	Comments	Funding Limitations
<i>Department of Health and Human Services (HHS)</i> Development Disabilities Services and Facilities Construction Act of 1970, as amended	Rehabilitation services and advocacy program	Those who are developmentally disabled	State developmental disability agency and council	Mentally retarded, epileptic, autistic individuals and those unable to function normally in society	Those who are developmentally disabled	At least two service categories within state	Possible	Must supplement or increase, not supplant, services. Include in 3-year state plan.	80-90% federal in poverty areas; 70-75% federal in other areas. Non-federal match may be in-kind. Formula grants to states. Maintain level of effort.
<i>Community Service Administration (CSA)</i> Community Services Act of 1974, as amended Title II	Community Action Programs (CAP)	Individuals and families with low incomes	State, city or group of communities with minimum population of 50,000; Indian reservation; designated by government agency with jurisdiction over entire area	Low income	Individuals or families with low incomes based on CSA poverty criteria	Varies; Community Action Agency (CAA) jurisdiction area	Possible	CAA must document transportation need in CAP; application reviewed by state; must be additional services.	Declining federal match - 80% in FY76, 60% in 1977; exceptions greater than \$300,000. In cash or in-kind non-federal match. Discretionary grants to locals.
Title V (Administered by HHS)	Head Start child development	Health nutritional, educational & social service programs	Public or private non-profit organization (many are CAA's)	Low-income pre-school children	Children and families with low incomes based on OMB poverty criteria; 10% handicapped	Community	Allowed	Include in annual plan. Local Head Start agency can own vehicles; transportation costs not required as separate line item. Must be additional services	80% federal; 20% non-federal cash or in-kind match. Discretionary grant to locals.
<i>Department of Labor (DOL)</i> Comprehensive Employment and Training Act of 1973 Titles II, III, VI	Employment programs	General population	Public or private non-profit agencies; private for profit organizations not eligible	Under- and unemployed youth	DOL unemployment criteria apply	Community	Possible	Existing general market and target market DRT services have used CETA funds for staffing	100% federal grant; no matching requirements.

Department Statute	Description	Provides Transport For	Provider Eligibility/ Administering Agency	Target Market	User Eligibility Restrictions	Area Coverage	Capital Purchase	Comments	Funding Limitations
ACTION Domestic Volunteer Services Act of 1973 Title II, Section 201	Retired Senior Volunteer Program (RSVP)	Elderly to Volunteer stations	Community service organizations	Elderly	At least aged 60, retired, able to work	Community	Allowed with prior approval	Volunteers used in existing target market paratransit services; sensitive to elderly needs	90% federal, 10% non-federal match
Title II, Section 221(a)	Foster Grandparents Program	Elderly with low-incomes and children with special problems	Community service organizations	Elderly	At least aged 60, OEO, retired, able to help children; set by Director	One or more communities	Allowed with prior approval	Possible 100% federal funding	Typically, 90% federal; 10% non-federal match

Source: Adapted from Reference 9.

APPENDIX D
SAMPLE VEHICLE INSPECTION AND
MAINTENANCE FORMS

List of Charts

New Vehicle Inspections
Michigan State Department of Transportation
Dial-A-Bat, Brockton, MA

Daily Inspections
Maine State Department of Transportation
Paratransit, Inc., Sacramento, CA

Weekly Inspections
THEM, Inc., Watertown, MA
Dial-A-Bat, Brockton, MA

Monthly Inspections
Small Bus Program, Michigan Department
of Transportation

Mileage Traveled Inspections
OATS, Missouri
4,000 miles
8,000
12,000
20,000
24,000
Paratransit, Inc., Sacramento, CA
3,500 miles
7,000



NEW BUS ACCEPTANCE CHECKLIST

Purchase Order No.	Vehicle Serial No.	License No.	Mileage
Year	Vehicle Make	Chassis Make	Vendor
Date Received	Pass.	Lift	Chassis Serial No.
Key Numbers:	Ignition	Door	Fare Box
			Vaults

SPECIFICATIONS COMPLIANCE

CHASSIS	SPECS.	ACTUAL	INTERIOR	SPECS.	ACTUAL
1. Wheelbase	_____	_____	1. Driver's Seat	_____	_____
2. Engine	_____	_____	2. Passenger Seats	_____	_____
3. Steering	_____	_____	Spacing	_____	_____
4. Front Axle	_____	_____	Single Width	_____	_____
5. Rear Axle	_____	_____	Double Width	_____	_____
6. G.V.W.	_____	_____	3. Aisle Width	_____	_____
7. Axle Ratio	_____	_____	4. Headroom	_____	_____
8. Battery	_____	_____	5. Flooring	_____	_____
9. Alternator	_____	_____	Steps	_____	_____
10. Power Brakes	_____	_____	Aisle	_____	_____
11. Frt. Brk. Size	_____	_____	Underseats	_____	_____
12. Rear Brk. Size	_____	_____	6. A/C BTU's	_____	_____
13. Fuel Tank	_____	_____	7. Heating BTU's	_____	_____
14. Stabilizer	_____	_____	8. Int. Mirror	_____	_____
15. Wheels	_____	_____	9. Angle View Lens	_____	_____
16. Tires	_____	_____	10. Fare Box	_____	_____
17. Trans. Type	_____	_____	Vaults (2)	_____	_____
18. Trans. Cooler	_____	_____	Keys (4)	_____	_____
19. Guarded Drvshft.	_____	_____	11. Grabrails	_____	_____
20. Cooling System	_____	_____	12. Stanchions	_____	_____
21. Clutch Type Fan	_____	_____	13. Spare Tire/Rim	_____	_____
			14. Snow Tires	_____	_____
			15. Tire Changing Tools	_____	_____
EXTERIOR			ACCESSIBILITY		
1. Entrance Door	_____	_____	1. Wheelchair Lift	_____	_____
Height	_____	_____	Door Height	_____	_____
Width	_____	_____	Power Up	_____	_____
2. Entrance Steps	_____	_____	Power Down	_____	_____
1st Step Height	_____	_____	Power Fold	_____	_____
2nd Step Height	_____	_____	Manual Override	_____	_____
Tread Depth	_____	_____	Auto. Stop	_____	_____
3. Rear Door	_____	_____	Wheel Stop	_____	_____
4. Windows	_____	_____	Platform	_____	_____
5. Bumpers	_____	_____	Width	_____	_____
6. Mirrors	_____	_____	Length	_____	_____
Sideview	_____	_____	Adjst. Speed	_____	_____
Convex	_____	_____			
7. Rustproofing	_____	_____	2. Securement Area	_____	_____
			Jump Seats	_____	_____
			Tie Downs	_____	_____
			Seat Belts	_____	_____
SAFETY EQUIPMENT					
1. Fire Ext.	_____	_____			
2. First Aid Kit	_____	_____			
3. Triangle & Flares	_____	_____			
4. Emerg. Exit Markings	_____	_____			
5. Roof Hatch	_____	_____			
6. Rear Door Buzzer	_____	_____			
7. Backup Buzzer	_____	_____			

INFORMATION FURNISHED WITH EACH VEHICLE

- | | |
|--|---|
| 1. Wiring Diagrams _____
2. Manuf. Statement of Origin _____
3. Repair & Parts Manuals _____
4. Maintenance Schedules _____ | 5. Structural Specifications _____
6. Operator's Instruction Manuals _____
7. Line Setting Tickets _____
8. Warranties _____ |
|--|---|

OPERATIONAL CHECKLIST

FLUID LEVELS

- _____ engine oil level
- _____ radiator
- _____ battery water level
- _____ brake fluid level
- _____ windshield washer fluid
- _____ transmission oil level
(with engine running)

LIGHTS

- _____ headlight – high beam
- _____ headlight – low beam
- _____ tail lights
- _____ turn signals – front
- _____ turn signals – rear
- _____ brake lights
- _____ back-up lights
- _____ running lights
- _____ 4-way flashers
- _____ dash lights
- _____ passenger lights
- _____ fare box light
- _____ entrance stepwell light
- _____ lift entrance light

GAUGES

- _____ amp or volt meter
- _____ water temperature
- _____ oil pressure
- _____ speedometer
- _____ fuel
- _____ miscellaneous

EQUIPMENT CONTROLS

- _____ front/rear heater
- _____ defroster
- _____ A/C condenser fans
- _____ driver fan
- _____ windshield wipers/washers
- _____ horn
- _____ door opener

GENERAL

- _____ controls and gauge locations, labels
- _____ interior and stanchion padding
- _____ flooring installation
- _____ seating installation
- _____ doors and windows
- _____ interior and exterior workmanship
- _____ scratches, overspray, dents, rust
- _____ missing, loose, stripped nuts, bolts, screws, rivets
- _____ water leakage test
- _____ road test

REMARKS

VEHICLE CHECK-IN

DATE: _____

C & E BODY NO.: _____

OUR VEHICLE NO.: _____

ITEM	REF#	OK	DEF.	COMMENTS
BODY				
General appearance				
Body damage				
Paint				
Logo				
Numbering				
Mirrors				
Doors				
Handles - Latches				
Signs Front				
" Rear				
Other				
INTERIOR				
Headliner				
Trim				
Padding				
Flooring				
Entrance plate				
Step treads				
Handrails				
Seats				
Seat mounting				
Passenger door operation				
Mirrors				
Other				
LIGHTING				
Head lights				
Parking lights				
Marker lights				
Brake lights				
School bus lights				
Turn signals				
Interior dome lights				
Dash lights				
Stepwell lights				
Other				
CHASSIS				
All Hose routing & mounting				
Tires - wheels - Hub caps				
Exhaust system				
Front suspension				
Rear Suspension				
Steering				
Brakelines				
Frame				
Under coating				
Other				

cc to
 COACH & EQUIPMENT
 W.T. LUDDY
 BAYSTATE MAINT. DEPT.
 B. ELLIS

INSPECTED BY _____
 Signature

Cont.

ITEM	REF#	OK	DEF.	COMMENT
<u>LEAKS</u>				
Engine oil				
Engine water				
Heater lines & fittings				
Heater lines & fittings				
A/C/ lines & fittings				
Brake cylinders				
Trans. seals-gaskets				
Differential				
Axle seals				
Fuel tank & lines				
Other				
<u>DRIVE TEST</u>				
Starter action				
Gauges				
Warning lights				
Brake operation				
Steering operation				
Trans. operation				
Heater-Front				
Heater-Rear				
Defroster				
A/C-Front				
A/C-Rear				
Back-up alarm				
Speedometer-record ()				
Tachograph-record ()				
Hubodometer-record ()				
Other				
<u>ACCESSORIES</u>				
Spare tire				
Jack, Handle, Lug Wrench				
Vinal pouch				
Litter receptacle				
Wheel Chocks				
Fire Extinguisher				
First Aid Kit & Holder				
Driver Manual & Warranty Card				
Triangle reflectors				
Other				

COMMENTS

If additional comment is needed on any item, number the item and explain below.
Use page 3 if necessary.

Handicap Vehicles only

ITEM	REF#	OK	DEF.	COMMENT
Lift Installation				
Lift Operation				
Aux. pump operation				
Hydraulic system leaks				
Limit switch ---UP				
Limit switch ---DOWN				
Sheet metal around lift				
Lift door restraints				
Wheel chair locks				
Wheelchair belts				
Passenger seat belts & retractors				
(6) 30 min. road flares				
24 Unit First Aid Kit				
5 lb. Fire Extinguisher				
Other				

ADDITIONAL COMMENTS

Driver's Daily Vehicle Condition Report or Repair Order

Agency _____

Vehicle No. _____ Location _____ Date _____

Speedometer Reading _____ Repairs By: _____

Date Repairs Made _____ Location _____

CHECK ITEM NEEDING ATTENTION Driver _____

PM Scheduled: 50-Hr. 100-Hr. 200-Hr. 300-Hr. 600-Hr. 1200-Hr.

PM Scheduled: 1000-Mi. 2000-Mi. 6000-Mi. 12,000-Mi. 24,000-Mi.

SAFETY EQUIPMENT

<input type="checkbox"/>	Fire Extinguisher
<input type="checkbox"/>	Fuses
<input type="checkbox"/>	Red Flogs
<input type="checkbox"/>	Torch or Reflectors
<input type="checkbox"/>	Accident Report Form

BRAKE SYSTEM

<input type="checkbox"/>	Reservoir
<input type="checkbox"/>	Air Leak
<input type="checkbox"/>	Adjust Service Brakes
<input type="checkbox"/>	Adjust Parking Brake
<input type="checkbox"/>	Brake Drag
<input type="checkbox"/>	Brake Release Lag
<input type="checkbox"/>	Brake Release Lag

STEERING SYSTEM

<input type="checkbox"/>	Power Steering
<input type="checkbox"/>	Pump Belt
<input type="checkbox"/>	Slack in System
<input type="checkbox"/>	Wheel Shimmy
<input type="checkbox"/>	Hard Steering
<input type="checkbox"/>	Pulls to Side

ENGINE

<input type="checkbox"/>	Smoke
<input type="checkbox"/>	Lacks Power
<input type="checkbox"/>	Adjust Idle
<input type="checkbox"/>	Oil Pressure
<input type="checkbox"/>	Water Temp.
<input type="checkbox"/>	Fan Belt
<input type="checkbox"/>	Water Leak
<input type="checkbox"/>	Oil Leak
<input type="checkbox"/>	Fuel Leak

CLUTCH

<input type="checkbox"/>	Adjust
<input type="checkbox"/>	Grabbing
<input type="checkbox"/>	Noisy
<input type="checkbox"/>	Slipping

TRANSMISSION

<input type="checkbox"/>	Transmission
<input type="checkbox"/>	Aux. Transm.
<input type="checkbox"/>	Transfer Case
<input type="checkbox"/>	Oil Leak
<input type="checkbox"/>	Noisy
<input type="checkbox"/>	Hard Shifting
<input type="checkbox"/>	Disengagement
<input type="checkbox"/>	Overheating
<input type="checkbox"/>	Control Linkage

ELECTRICAL

<input type="checkbox"/>	Starter
<input type="checkbox"/>	Generator
<input type="checkbox"/>	Battery(s)
<input type="checkbox"/>	Wiring
<input type="checkbox"/>	Switches
<input type="checkbox"/>	Turn Signals
<input type="checkbox"/>	Flasher Light
<input type="checkbox"/>	Head Lights
<input type="checkbox"/>	Tail Lights
<input type="checkbox"/>	Stop Lights
<input type="checkbox"/>	Trailer Cable
<input type="checkbox"/>	Panel Lights

AXLE, REAR

<input type="checkbox"/>	Wheel Bearing
<input type="checkbox"/>	Axle Shaft
<input type="checkbox"/>	Power Divider
<input type="checkbox"/>	Gear Noise
<input type="checkbox"/>	Housing Leak
<input type="checkbox"/>	Driveline
<input type="checkbox"/>	U-Joint
<input type="checkbox"/>	Suspension
<input type="checkbox"/>	Spring U-Bolts

EXHAUST

<input type="checkbox"/>	Muffler
<input type="checkbox"/>	Pipes
<input type="checkbox"/>	Gaskets
<input type="checkbox"/>	Clamps

CAB

<input type="checkbox"/>	Windshield
<input type="checkbox"/>	Door Glass
<input type="checkbox"/>	Door
<input type="checkbox"/>	Upholstery
<input type="checkbox"/>	Floor Mat
<input type="checkbox"/>	Heater
<input type="checkbox"/>	Defroster
<input type="checkbox"/>	W. Wipers
<input type="checkbox"/>	Mirrors
<input type="checkbox"/>	Horn
<input type="checkbox"/>	W. Washer
<input type="checkbox"/>	Speedometer
<input type="checkbox"/>	Tachometer
<input type="checkbox"/>	Hourmeter

TIRES

<input type="checkbox"/>	Flat
<input type="checkbox"/>	Slow Leak
<input type="checkbox"/>	Damaged
<input type="checkbox"/>	Tread Wear
<input type="checkbox"/>	Mating

Inspection Sticker

Wash Job

Comments:

BUS DAILY PREVENTIVE MAINTENANCE INSPECTION
AS REQUESTED BY 14243 OF THE CALIFORNIA
ADMINISTRATION CODE, TITLE 5

BUS IDENTIFICATION (Finish _____)

MAKE _____ YEAR _____ BUS# _____ LICENSE# _____ DATE _____ MILEAGE: (Start _____)

(Total _____)

(Start _____)

HOURS: (Finish _____)

(Total _____)

The daily preventive maintenance inspection by the operator shall include but not be limited to the following:

- | <u>O.K.</u> | <u>NEEDS
ATTENTION</u> | |
|--------------------------|----------------------------|--|
| <input type="checkbox"/> | <input type="checkbox"/> | Maintain water & oil & all vehicle fluid levels in accordance with the manufacturer's recommendations. |
| <input type="checkbox"/> | <input type="checkbox"/> | Check emergency exit & all warning devices to determine if they are working. |
| <input type="checkbox"/> | <input type="checkbox"/> | Test horns. |
| <input type="checkbox"/> | <input type="checkbox"/> | Check driver's seat & belts for wear and securement. |
| <input type="checkbox"/> | <input type="checkbox"/> | Determine that all doors, or emergency releases and windows are in operating condition. |
| <input type="checkbox"/> | <input type="checkbox"/> | Check securement of all seats, handrails and modesty panels. |
| <input type="checkbox"/> | <input type="checkbox"/> | Check all interior and exterior lighting systems. |
| <input type="checkbox"/> | <input type="checkbox"/> | Determine that all heating, cooling and ventilating systems are working. |
| <input type="checkbox"/> | <input type="checkbox"/> | Check all glass and mirror for cracks and cleanliness. |
| <input type="checkbox"/> | <input type="checkbox"/> | Determine that windshield wipers and washers are working. |
| <input type="checkbox"/> | <input type="checkbox"/> | Determine that fire extinguishers & first aid kit are maintained and in operating condition. |
| <input type="checkbox"/> | <input type="checkbox"/> | Check radio operation (on) |

- | <u>O.K.</u> | <u>NEEDS
ATTENTION</u> | |
|--------------------------|----------------------------|--|
| <input type="checkbox"/> | <input type="checkbox"/> | Check all tires & lug nuts. If bus has hubcap, don't have to remove, just kick tire. |
| <input type="checkbox"/> | <input type="checkbox"/> | Check lift operation. |
| <input type="checkbox"/> | <input type="checkbox"/> | Perform the following brake safety check: |
| <input type="checkbox"/> | <input type="checkbox"/> | 1. Test parking brake. |
| <input type="checkbox"/> | <input type="checkbox"/> | 2. Check brake pedal for brake adjustment. |

Other Mechanical Difficulties

Service Stops

Gasoline _____ Gallons)

Oil _____ Quarts) _____ Mileage

Inspected by: _____

jhd 11.15.78

DRIVER'S WEEKLY VEHICLE REPORT

(TO BE COMPLETED EACH FRIDAY)

EACH ITEM MUST BE ANSWERED ✓ = O.K. X = PROBLEM

VEHICLE REG. # _____ VEHICLE # _____ VEHICLE MILEAGE _____ DATE _____

ENGINE

Starting
Oil Pressure
Over Heating
Stalling
Skips
Knocks
Oil Leaks
Fuel Leaks

ELECTRICAL

Battery
Horn
Wipers
Head Lights
Parking Lights
Emergency Lights
Bus Flashers
Directionals
Dashboard Lights
Lift Light
Step Light
Interior Lights
Front Heater
Rear Heater
Defroster
Alternator
Brake Lights

BRAKES

Emergency

Low
Pull
Squeal
Stick
Spongy
Leak

TRANSMISSION

Slips
Leaks
Burning
Noisy

REAR END

Noisy
Leaks
Shocks

FRONT END

Steering
Shimmy
Rattle
Shocks
Pulls

TIRES

Flat
Cut
Worn
Spare
Pressure

EXTERIOR

Windows
Mirrors
Rattles
Damage
Clean

INTERIOR

Seat Belts
Tie Downs
Seats
Clean

TIRE IRON & JACK

LIFT

Inoperable
Tilts
Lip
Fluid
Opening & Closing
Noisy
Slow
Fast
Control Cord

EMERGENCY EQUIPMENT

3 Flares
3 Reflectors
Full First Aid Kit
4 Vomit Bags
3 Chux Pads*
2 Blankets*
Fire Extinguisher - Full Charge
Flashlight
3 Mouth Gags*

MISCELLANEOUS EQUIPMENT

Registration
Punch
Map-Book
Map-Streetguide

TWO-WAY RADIO

Noisy
Poor Receive
Poor X'mit

COMMENTS/PROBLEMS

DRIVER'S SIGNATURE

*NON-RIDE VEHICLES ONLY

Weekly Maintenance Check

Van # _____ Mileage _____ Date _____

- _____ 1. Check and correct front suspension
- _____ 2. Check and correct power steering lines
- _____ 3. Check steering box mounting
- _____ 4. Check fluid levels and correct
- _____ 5. Check tire pressure
 Front _____ Rear _____ (90 PSI)
- _____ 6. Inspect heater lines for chafing
- _____ 7. Check all instruments and lights
- _____ 8. Check seat mounting
- _____ 9. Check front door operation and bracket mounting
- _____ 10. Check lift operation and lift lock

Comments:

Mechanic _____

MDSHT 3008 (1/77)

PREVENTIVE MAINTENANCE INSPECTION WORK SHEET

VEHICLE NO. _____

- OK
- ADJUSTMENT MADE
- NEEDS ATTENTION

PERFORM MONTHLY
ALL DART VEHICLES

DATE _____

MILEAGE _____

SPECIAL INSTRUCTIONS
FOR REPAIRS NEEDED _____

PREPARE FOR INSPECTION

- CHECK DRIVERS REPORT
- REVIEW MAINTENANCE HISTORY
- WASH VEHICLE

COMMENTS

START UP AND DRIVE (CHECK OPERATION OF:)

- STARTING
- PARKING BRAKE
- SERVICE BRAKE
- TRANSMISSION
- HORN
- SPEEDOMETER

REMAIN IN VEHICLE (CHECK OPERATION OF:)

- FUEL GAUGE
- OIL GAUGE
- BATTERY CHARGING GAUGE
- WINDSHIELD WASHER & WIPERS
- STEERING WHEEL FREE PLAY
- REGISTRATION
- HEAD LIGHTS, HI INDICATOR
- HEAD LIGHTS, LOW
- TURN SIGNAL, INDICATORS
- 4 WAY FLASHER, INDICATORS
- INTERIOR LIGHTS
- INSTRUMENT PANEL LIGHTS
- HEATER & DEFROSTER
- AIR CONOITIONER
- ALL WINDOW GLASS
- DOORS
- SEATS
- SAFETY EQUIP.

OUTSIDE INSPECTION (CHECK OPERATION OF:)

- HOOD
- BUMPERS, BODY DAMAGE
- ALL LIGHTS
- FUEL CAP
- FRONT END, KING PINS, WHEEL BEARINGS, TIE ROD ENDS
- OUTSIDE MIRRORS
- WHEELS & RIMS, TIGHTEN LUGS
- TIRES, CHECK WEAR, CRACKS AND PRESSURE RECORD _____ LBS. PER SQ. IN.

UNDER HOOD (CHECK OPERATION OF:)

- AIR COMPRESSOR, MOUNTING & BELT TENSION
- STEERING GEAR & SHAFT (LUBE)
- POWER STEERING HOSES & OIL LEVEL
- THROTTLE LINKAGE
- WATER PUMP & FAN BELT
- WATER PUMP & FAN HUB (LUBE)
- C/CASE BREATHER, CLEAN/CHANGE
- AIR FILTER, CHANGE
- EXHAUST SYSTEM, TIGHTEN
- ENGINE OIL, CHANGE
- OIL FILTER, CHANGE
- FUEL FILTER, CHANGE
- FUEL LEAKS, CORRECT
- RADIATOR, CHECK LEVEL
- RADIATOR, PRESSURE CHECK
- RADIATOR, CLEAN FRONT
- HOSES, CHECK & ADJUST
- ANTI FREEZE PROTECTED _____ °
- ALTERNATOR, BELT TENSION, TERMINALS, CHECK & LUBE
- BATTERY, CHECK WATER LEVEL
- BATTERY, CLEAN CABLES
- MASTER CYLINDER, FILL
- LUBRICATE ALL FITTINGS

UNDER CHASSIS

- ENGINE & TRANS. MTG. BOLTS CHECK & ADJUST
- BODY MTG. BOLTS CHECK & ADJUST
- TRANSMISSION, CHECK GEAR OIL LEVEL
- TRANSMISSION, CHECK COVER, BELL & SEAL AREAS FOR LEAKS
- EXHAUST MUFFLER, TAIL PIPE HANGERS, TIGHTEN IF LOOSE
- DIFFERENTIAL, CHECK GEAR OIL LEVEL & CLEAN BREATHER
- DIFFERENTIAL, CHECK FOR LEAKS
- BRAKES, ADJUST IF NEEDED
- SPRINGS, SHACKLES, U BOLTS, CHECK FOR CRACKS, RUST-TIGHTEN

DRIVE OFF & PARK

- ENGINE OIL, CHECK LEVEL
- HOOD LATCH, CHECK
- RECORD ALL PERTINENT INFO. IN VEHICLE RECORDS

MECHANIC SIGNATURE _____

OLDER ADULTS TRANSPORTATION SERVICE, INC.
4,000-MILE MAINTENANCE

VENDOR: All service listed on this page must be completed, checked off (x), and this page returned to the OATS driver with a copy of the bill. THIS SHEET IS NOT A BILL. Please sign below.

Actual Mileage _____
 Bus No. _____

MAINTENANCE	Check (x)	COST		
		Parts/ Materials	Labor	Total
Change engine oil.				
Replace engine oil filter (every 2nd oil change).				
Check power steering fluid level and add as necessary.				
Inspect tires for wear.				
Check fluid level in battery.				
Inspect fluid levels in the transmission and rear axle.				
Lube brake pedal linkage points and parking brake control lever				
Inspect fluid level in brake master cylinder				
Lube steering linkage ball joints and wheel stops				
Inspect all belt drives for cracks, cuts and replace as necessary.				
Check belts for tension, adjust as necessary				
Check brake and power steering hoses for deterioration and leaks. Inspect all hose connections such as clamps and couplings.				

TOTAL

Service Performed By: _____

Distribution: Area Managers (1)

OLDER ADULTS TRANSPORTATION SERVICE, INC.
8,000-MILE MAINTENANCE

VENDOR: All service listed on this page must be completed, checked off (x), and this page returned to the OATS driver with a copy of the bill. THIS SHEET IS NOT A BILL. Please sign below.

Actual Mileage _____
 Bus No. _____

MAINTENANCE	Check (x)	COST		
		Parts/ Materials	Labor	Total
Clean carburetor air filter.				
Check exhaust system for leaks, missing or damaged parts.				
Check headlight aim.				
Check cooling system for leaks, radiator cap for proper vacuum sealing and operation, & antifreeze concentration.				
Check belts and operation of control for air conditioning unit.				
Inspect seals on suspension ball joints, steering linkage pivots and U-joints.				
Lubricate body mechanisms: hood, door hinges, window latches.				
Apply solvent to carburetor choke shaft.				
Apply solvent to fast idle cam & pivot pin.				
Change oil filter				
Additional maintenance:				

TOTAL

Service Performed By: _____

Distribution: Area Managers (1), Home Office (1).

OLDER ADULTS TRANSPORTATION SERVICE, INC.

12,000-MILE MAINTENANCE

VENDOR: All service listed on this page must be completed, checked off (x), and this page returned to the OATS driver with a copy of the bill.
THIS SHEET IS NOT A BILL.
 Please sign below.

Actual Mileage _____
 Bus No. _____

MAINTENANCE	Check (x)	COST		
		Parts/ Materials	Labor	Total
Check PCV valve hose & passages for proper operation. If valve is plugged or sticking, replace.				
Remove and clean crankcase inlet air cleaner.				
Exhaust gas recirculation system: check all passages & moving parts for deposits, plugging and sticking. Check system for leaks. Replace any leaking, hardened or cracked hoses, or faulty connectors between carburetor, manifold, EGR control valve & vacuum amplifier.				
Inspect brake linings.				
Inspect front wheel bearings. Check lubricant for quantity and quality. Clean & repack if the grease is low in quantity or contaminated.				
Drain, flush & refill cooling system. (every fall only)				
Additional maintenance:				

Service Performed By: _____

TOTAL

Distribution: Area Managers (1), Home Office (1).

Revised 6/79

OLDER ADULTS TRANSPORTATION SERVICE, INC.
20,000-MILE MAINTENANCE

VENDOR: All service listed on this page must be completed, checked off (x), and this page returned to the OATS driver with a copy of the bill. THIS SHEET IS NOT A BILL. Please sign below.

Actual Mileage _____
 Bus No. _____

MAINTENANCE	Check (x)	COST		
		Parts/ Materials	Labor	Total
Check ignition cable resistance. Replace faulty, damaged or faulty cables.				
Service manifold heat control valve.				
Adjust automatic choke.				
Replace spark plugs.				
Check and adjust timing, RPM & Air-fuel mixture according to specs in service manual.				
Replace crankcase PCV valve.				
Replace fuel filter.				
Change fluid and filter for automatic transmission.				
Check distributor cap and rotor				
Inspect emission hoses for evidence of heat and mechanical damage.				
Additional Maintenance:				

TOTAL

Service Performed By: _____

Distribution: Area Managers (1), Home Office (1).

OLDER ADULTS TRANSPORTATION SERVICE, INC.

24,000-MILE MAINTENANCE

VENDOR: All service listed on this page must be completed, checked off (x), and this page returned to the OATS driver with a copy of the bill.
THIS SHEET IS NOT A BILL.
 Please sign below.

Actual Mileage _____
 Bus No. _____

MAINTENANCE	Check (x)	COST		
		Parts/ Materials	Labor	Total
Drain and refill rear axle fluid.				
Replace carburetor air filter.				
Relubricate front suspension ball joints.				
Replace carburetor air cleaner.				
Inspect rear wheel bearings. Clean and repack as necessary & whenever brake linings are replaced or brake drums resurfaced.				
Replace crankcase PCV valve.				
Additional Maintenance:				

TOTAL

Service Performed By: _____

Distribution: Area Managers (1), Home Office (1)

Revised 6/79

LEVEL A INSPECTION
(3500 MILES)

AGENCY _____ VEHICLE NO. _____ MILEAGE _____ DATE _____

UNDERCARRIAGE

- _____ Check fuel tank lines for leaks
- _____ Check differential for leaks
- _____ Check rear springs, shackles, and shocks
- _____ Check driveshaft center support and u-joint
- _____ Check transmission for leaks
- _____ Check shift and clutch linkage
- _____ Check front suspension and shocks
- _____ Check steering linkage
- _____ Check exhaust system
- _____ Lubricate

UNDERHOOD

- _____ Pressure test cooling system
- _____ Check coolant/antifreeze level
- _____ Check cooling system circulation
- _____ Check brake fluid level
- _____ Check power steering fluid level
- _____ Check battery and cables
- _____ Check starting and charging system
- _____ Check windshield water fluid

TIRES

- _____ Check tire wear
- _____ Check for nails, glass, etc.
- _____ Check for tread separation
- _____ Check air pressure
- _____ Check lug nuts for tightness

ENGINE

- _____ Check all fuel lines and connections for leaks
- _____ Check all belts for looseness or signs of wear
- _____ Check all hoses for leaks or signs of wear
- _____ Check for loose wiring or vacuum lines
- _____ Check air filter--clean
- _____ Check accelerator linkage
- _____ Change oil and filter

ACCESSORIES

- _____ Check heater output
- _____ Check air conditioner output

BRAKES

- _____ Check shoes and pads for lining wear
- _____ Check brake lines for leaks or checking
- _____ Check brake vacuum hoses
- _____ Check brake adjustment
- _____ Check brake pedal clearance
- _____ Check emergency brake

CONTROL PANEL

- _____ Check warning lights and buzzers
- _____ Check dash lights
- _____ Check interior lighting
- _____ Check gauges
- _____ Check headlamps and running lights
- _____ Check license plate light
- _____ Check dimmer switch
- _____ Check brake lights and directional signal
- _____ Check emergency flasher
- _____ Check reverse lights
- _____ Check horn
- _____ Check windshield wiper operation
- _____ Check radio operation

BODY INTERIOR

- _____ Check first aid kit
- _____ Check fire extinguisher
- _____ Check seats for tears and looseness
- _____ Check floors for tears or loose wheel-chair track
- _____ Check fare box for secureness
- _____ Check emergency exit
- _____ Check window operation
- _____ Check rearview mirror
- _____ Check for loose body bolts

BODY EXTERIOR

- _____ Check all windows
- _____ Check sideview mirrors
- _____ Check attached body parts for looseness
- _____ Check windshield wiper blades
- _____ Check for loose body bolts

IGNITION ANALYSIS

- _____ Check firing voltage (secondary circuit)
- _____ Check reserve voltage (isolate coil)
- _____ Check fuel filter
- _____ Check timing
- _____ Check idle and adjust carburetor

ROAD TEST VEHICLE

- Check acceleration
- Check braking
- Check rattles, noises
- Check steering freeplay and drift

WORK NEEDED: _____

ACTION TAKEN: _____

COMMENTS: _____

MECHANIC'S SIGNATURE _____

LEVEL B INSPECTION
(7000 MILES)

AGENCY _____ VEHICLE NO. _____ MILEAGE _____ DATE _____

UNDERCARRIAGE

- _____ Check fuel tank lines for leaks
- _____ Check differential for leaks
- _____ Check rear springs, shackles, and shocks
- _____ Check driveshaft center support and u-joint
- _____ Check transmission for leaks
- _____ Check shift and clutch linkage
- _____ Check front suspension and shocks
- _____ Check steering linkage
- _____ Check exhaust system
- _____ Lubricate
- _____ Clean, inspect, and repack wheel bearings

UNDER HOOD

- _____ Pressure test cooling system
- _____ Check coolant/antifreeze level
- _____ Check cooling system circulation
- _____ Check brake fluid level
- _____ Check brake fluid level
- _____ Check power steering fluid level
- _____ Check battery and cables
- _____ Check starting and charging system
- _____ Check windshield water fluid

TIRES

- _____ Check tire wear
- _____ Check for nails, glass, etc.
- _____ Check for tread separation
- _____ Check air pressure
- _____ Check lug nuts for tightness

ENGINE

- _____ Check all fuel lines and connections for leaks
- _____ Check all belts for looseness or signs of wear
- _____ Check all hoses for leaks or signs of wear
- _____ Check for loose wiring or vacuum lines
- _____ Check air filter--clean
- _____ Check accelerator linkage
- _____ Change oil and filter

ACCESSORIES

- _____ Check heater output
- _____ Check air conditioner output

BRAKES

- _____ Check shoes and pads for lining wear
- _____ Check brake lines for leaks or checking
- _____ Check brake vacuum hoses
- _____ Check brake adjustment
- _____ Check brake pedal clearance
- _____ Check emergency brake

CONTROL PANEL

- _____ Check warning lights and buzzers
- _____ Check dash lights
- _____ Check interior lighting
- _____ Check gauges
- _____ Check headlamps and running lights
- _____ Check license plate light
- _____ Check dimmer switch
- _____ Check brake lights and directional signal
- _____ Check emergency flasher
- _____ Check reverse lights
- _____ Check horn
- _____ Check windshield wiper operation
- _____ Check radio operation

BODY INTERIOR

- _____ Check first aid kit
- _____ Check fire extinguisher
- _____ Check seats for tears and looseness
- _____ Check floors for tears or loose wheel-chair track
- _____ Check fare box for secureness
- _____ Check emergency exit
- _____ Check window operation
- _____ Check rearview mirror

BODY EXTERIOR

- _____ Check all windows
- _____ Check sideview mirrors
- _____ Check attached body parts for looseness
- _____ Check windshield wiper blades

IGNITION ANALYSIS

- _____ Check firing voltage (secondary circuit)
- _____ Check reserve voltage (isolate coil)
- _____ Check fuel filter
- _____ Check timing
- _____ Check idle and adjust carburetor
- _____ Change plugs
- _____ Scope check (including primary and secondary ignition)

ROAD TEST VEHICLE

- Check acceleration
- Check braking
- Check rattles, noises
- Check steering freeplay and drift

WORK NEEDED: _____

ACTION TAKEN: _____

COMMENTS: _____

MECHANIC'S SIGNATURE

APPENDIX E

OUTLINE FOR WRITING TECHNICAL SPECIFICATIONS

[E.1 Writing a Specification

This chapter will provide the how of writing a set of technical specifications. As you read through this, keep in mind that each contract is different from the last one and will contain variations that you will need to work out. Always remember that any specification should cover all the materials and circumstances that are peculiar to a given project. It becomes very important that you screen all written materials carefully . . .

What is a "Technical Specification"?

The "Technical Specifications" in a set of Contract Documents represent the "contractual-technical" portion of the Contract Documents. Its purpose, in most situations, is to "define the quality and types of workmanship and materials upon which the Contract is Based." For some contracts, such as for the purchase of equipment, the Technical specifications may replace at least some of the functions of drawings, which are used to "define the physical relationships of materials upon which the Contract is based.

Where do You Begin?

The first step is to decide what you want. List informally the features you desire on the item you are receiving bids for, whether it be a bus, a radio, or a service. Use this list to begin an outline which can be used as a preliminary specification. Arrange the features into a logical order, which could be carried over into the final specification. A checklist of possible items, possibly from another set of technical specifications, may be used so you can avoid overlooking some category that needs to be included.

An example of such an arrangement can be seen in the Technical Specifications for the Transbus, prepared by UMTA. The body of the specifications was arranged in the following manner:

- Body (of the bus)
 - Shell
 - Operating components
 - Interior trim
 - Windows
 - Insulation
 - Ancillary features
- Chassis
 - Propulsion system
 - Final drive
 - Suspension
 - Steering
 - Brakes
 - General chassis
 - Interior climate control
 - Radio and public address

The arrangement is logical and could easily be expanded into a full set of specifications (as was done). All that is needed to complete the technical specifications is a format.

What Format Should You Use?

Only one format will be suggested — one that is similar to the [Construction Specifications Institute] (CSI) format. It is suggested that you arrange your Technical Specifications into three parts, similar to the one used by CSI. The three-part format would look like this:

- Part 1: General
- Part 2: Product
- Part 3: Execution

Part 1 encompasses certain aspects of the project requirements that are often included in the General Conditions. However, they belong with the Technical Specifications, because they pertain particularly to the Product . . .

The section on the Product completely describes what is to be provided by the Contractor, whether equipment or services. The more complete your description of the product, the more likely it will be that you get what you want at a good price. Do be careful not to specify the product in too much detail, because that may limit the number of bidders more than you wish to.

Part 3, Execution, covers what the Contractor does. With the exception of service contracts, the specifications are for products produced in the manufacturer's plant and delivered to the buyer in accordance with a specific schedule. Since the work is done on the Contractor's property, the buyer is not responsible for injuries. Therefore, the only execution requirements for equipment have to do with pre-delivery and post-delivery inspections . . .

Of course, for service contracts, execution is the most important factor in the Contract, so this could be the largest of the three parts.

[E.]2 Sample

A sample outline for a mythical set of Technical Specifications follows. Examine the sample as you develop your own specifications. It should be helpful.

Technical Specifications for _____

Part 1: General

Items Covered by These Specifications	Scope (Describe what this specification is all about.)
The specifications which follow . . .	
Overall Requirements	(Include all the basic criteria here. Details such as physical size and weight, capacity, range, service life, accessibility for repairs, and interchangeability need to be discussed.)
Items not Covered	(Describe all such items, tell who is to furnish them and how. Avoid use of ". . . by others" if it will be furnished as part of this contract.)
	Definitions (Define any terms not normally used, but used here. Just don't get carried away and list too many.)

	Applicable Regulations
Safety Requirements	(List requirements of local, state, or Federal laws which must be met while performing the services, or which the equipment must meet under normal use.)
Pollution Requirements	(Use when applicable. This could refer to emissions, disposal of waste, etc., [occurring during the performance of services or when the equipment] is in use.)
	Quality Assurance
Production Quality Control	(Insert a standard paragraph here, describing function and lines of responsibility. Refers mainly to production of equipment, though could be retitled and rewritten for use with a service contract.)
Organization Function	(Include range of responsibilities, including a note on how quality assurance will be achieved on supplied parts.)
Records	(Describe marking requirements for inspected items, test-data retention and availability.)
Measuring and Testing Facilities	(General comments on measuring and testing devices, plus use of standards for calibration.)
Inspection	(Note the need for a system used to keep track of status of inspection and documentation of same.)
	Warranty
Requirements	(General statement on requirement for warranty from Contractor.)
Guaranty	(Statement will vary according to what is to be furnished. Express in terms of miles, time, or whatever is appropriate.)
Detection and Repair of Defect	(Describe how [a] defect is to be corrected, [should there be one,] how parts are to be supplied, and who pays.)
Reimbursement for Labor	(Should the Public Agency incur any costs, tell how the Contractor will reimburse. Be sure to include fringe benefits and overhead costs.)
Engineers/Technical Assistance	(When you get new equipment, there may be problems. You may need some technical assistance.)
Spare Parts	(The Contractor must assure you of access to spare parts. Specially made parts can be expensive.)
Warranty after Replacement/Repairs	(A statement needs to be made about the continuance of the warranty after a defect has been corrected.)

Part 2: Product (the Transbus Specifications were chosen for this example.)

Body

Shell

Operating Components

- A. Doors
 - 1. Control Closing force
 - 2. Actuator
 - 3. Emergency operation

(Listed are the main headings . . . Break down the item to the most meaningful level. An example could be the Operating Components [See left.] For additional help, see a set of specifications you feel are good ones.)

Interior Trim

Windows

Insulation

Ancillary Features

Chassis

Propulsion System

Final Drive

Suspension

Steering

(Note: It is a good idea to include some drawings to clarify some detail. For example, drawings showing door openings and seat configuration can be most helpful.)

Brakes

General Chassis

Interior Climate Control

Radio and Public Address

Part 3: Execution

Pre-delivery Tests

(Describe how the tests will be done, by whom, and [include] something on documentation. If the Public Agency is to witness the tests, state how the arrangements will be made.)

Post-delivery Tests

(Provide for method and time limits applicable for the Public Agency to complete the tests.)

[E.]3 Final Form

Take the outline, once it is complete, and write up the details . . . You may be tired of writing by now, but it is a good idea to go over them thoroughly once again to be sure that there are no conflicting provisions and that the statements made reflect your desires adequately.

E.4 Outline Specifications for Transit Services

Part 1: General

Scope

Items Covered by these Specifications

The specifications which follow describe the services to be furnished under this Contract, including performance standards, non-performance measures, and control of the project, including accounting requirements.

Overall Requirements

Work covered by these specifications includes the furnishing of buses, drivers, and all associated supplies and services necessary to provide the following scheduled transit services:

(Here list the services desired.)

Items not Covered

The Public Agency shall furnish all other equipment and services necessary for the operation of the proposed transit services. Those items of equipment and services include, but are not limited to, the following:

(Here list the services/equipment furnished by the Public Agency.)

Definition

The following definitions of terms shall apply:

- Small buses -** Buses with a minimum rated capacity of 16 persons
- Medium buses -** Buses with a minimum rated capacity of 20 persons
- Large buses -** Buses with a minimum rated capacity of 45 persons

Applicable Regulations

Safety Requirements

Contractor shall comply with all applicable federal, state, and local laws and regulations covering transit equipment, driver education and licensing, and driving performance. These include:

(Make a list.)

Pollution Requirements

Exhaust emissions from transit equipment used in the performance of the transit services covered by this contract shall not exceed the following levels:

(Here list the regulated components of the exhaust emissions and the required maximum levels.)

Quality Assurances

Organization Function

The Contractor shall provide an adequate number of personnel within his/her organization with the authority and responsibility to assure driver and equipment performance standards as specified in these documents. The quality assurance organization shall be directly responsible to the Contractor's top management.

Quality of Services

The quality assurance organization shall have the following minimum functions:

1. Verify adherence to the time schedule.
2. Ensure that safe driving practices are observed.
3. Check that operating personnel maintain a neat and clean appearance and treat passengers with courtesy.
4. Require that transit equipment is clean and in good operating condition.

Records

Inspection records shall be maintained and made available to the Contracting Officer for his/her inspection.

Part 2: Products

Equipment Furnished

Transit Buses

(List the number and types of buses required for the services, plus any requirements for optional equipment — such as air conditioning.)

Condition of Equipment

(If you wish to establish any standards of equipment cleanliness or operating conditions, this would be the place to make those statements.)

Part 3: Execution

Performance Standards

Time Schedule

(Describe the time schedule to be followed by the buses and any deviations allowed.)

Service Standards

(Here make any appropriate statements regarding state of bus operator training, adherence to standards of safe driving, and such indicators of good customer service as courtesy, appearance of bus operator.)

Financial Records

Accounting Requirements

(Establish the Contractor Accounting requirements here that will enable you to meet your accounting commitments in connection with your contract with the Public Transit Division.)

Revenues

(Provide for the disposition of all funds collected by the Contractor in connection with the services provided under the Contract.)

Audit

(State that the Contractor shall permit you, the Public Agency, and/or the Public Transit Division to perform an audit of records connected with the project.)

Source: Reference 65.

APPENDIX F

LIFE-CYCLE COSTING METHOD

Although the total operating costs of a vehicle are from one-and-a-half to two times the cost of its purchase, only a few municipalities evaluate both operating and purchasing costs (i.e., life-cycle costs) when selecting a vehicle. For the municipalities that currently consider only the lowest bid price, a life-cycle costing model is provided in this appendix which can be formally or informally adopted as a guide to procurement decisions.

A formal use of the model . . . requires that bid proposals from competing suppliers incorporate estimates of vehicle operating costs as well as the purchase price. In this case, the municipality would have to specify exactly which costs were to be estimated by the bidder, mindful of two potential pitfalls. First, if the costs of a particular aspect of owning the vehicle are somewhat uncertain (e.g., maintenance costs), the bidder is likely to inflate the cost element above the cost that could reasonably be expected. Second, potential legal challenges to contract awards require that cost estimates have a sound basis in fact. While the Environmental Protection Agency (EPA) mileage ratings . . . provide such a basis in the case of fuel costs, estimates of maintenance costs are likely to be more subjective. Eventually, additional Federally mandated product specifications will provide a more suitable legal basis for formal life-cycle cost bidding.

Municipalities may find that an informal application of life-cycle costing is more appropriate from both legal and economic standpoints. Such an application [involves] an in-house life-cycle cost analysis to establish a set of narrowly defined vehicle performance criteria necessary to remain below an acceptable life-cycle cost ceiling. For example, the formal bid specifications could establish an average EPA-based miles-per-gallon standard assuming 60 percent city and 40 percent highway driving and a gross vehicle weight ceiling for acceptable bids. The list of specifications could be expanded to include many of the items mentioned in this report.

Even partial life-cycle cost analysis which considers only the fuel and purchasing costs provides a truer picture of the total owning cost of a vehicle than the initial cost alone. The life-cycle costing model that follows can be as simple or as complex as the cost information . . . available to the reader allows . . . The reader may use these costs in the analysis if local data [are] unavailable.

LIFE-CYCLE COST MODEL

The life-cycle costing methodology presented below consists of the four essential steps . . . Instructions and worksheets are provided, and a sample analysis is included.

Step 1: Collect Necessary Data

The life-cycle cost of a vehicle includes the purchase price, the total costs of fuel, maintenance, and insurance, as well as any other costs which may be associated with ownership.

The resale value of a vehicle at the end of its life in the fleet is a value rather than a cost and should also be included in the analysis. To compute the life-cycle cost, it is

useful to assemble all of the relevant and available information used in the analysis; Worksheet [1] is provided for that purpose. Note that some of the items of information in the Worksheet are optional, which means that a satisfactory analysis can be performed without them, although the results of the analysis will be more accurate if all costs can be estimated.

This section defines the data elements . . . required to analyze the life-cycle cost of a vehicle, and suggests sources of information for obtaining or estimating [them]. The elements to be defined are listed in Worksheet [1] along with a summarized list of information sources.

Required Data Elements

The first seven elements listed in Worksheet [1] are essential for compiling a basic life-cycle cost analysis.

1. *Purchase Price:* The purchase price of the complete vehicle, including all optional equipment, dealer preparation, and delivery, should be available from the local automobile or truck dealership.
2. *Expected Annual Mileage:* The anticipated usage of the new vehicle can be determined from historical data on the vehicle(s) it will replace. Only . . . estimated mileage is required, not a precise value . . .
3. *Number of Years the Vehicle is to Remain in the Fleet:* The anticipated life of the vehicle in the fleet can be estimated from historical data or by the appropriate department head.
4. *Expected Resale Value:* The salvage value of the vehicle when it reaches the end of its lifetime in the fleet can be estimated by department heads based upon their experience. If vehicles are typically held until fully depreciated, a salvage value of zero may be assumed.
5. *Acceptable Discount Rate:* To recognize that procurement funds could be diverted to other investments with a positive return, it is common practice to "discount" all expenses to be incurred in the future, making them comparable to initial costs incurred in the present. The selection of a discount rate is a local policy decision, although it is recommended that the rate be set at least as high as the level of interest rates available in savings bank accounts.
6. *Fuel Economy of the Vehicle in Miles Per Gallon:* The fuel economy of new passenger cars and trucks is rated by the [EPA]. These ratings may be used directly, or modified to reflect past experience in fleet fuel economy . . . Similar fuel economy standards for heavy-duty trucks and buses are not available.
7. *Price of Fuel:* [This is] the current price of fuel per gallon to the municipality . . .

Optional Information

The seven elements listed above are sufficient to complete a basic life-cycle cost analysis. It is to the advantage of the municipality, however, to consider as many of the total vehicle-owning costs as possible. If the three optional items listed in Worksheet [1] can be included, a more accurate and complete estimate of the actual life cycle cost can be made.

8. *Estimated Annual Maintenance Cost:* [This includes] charges for labor and parts, and may be estimated from the repair records of similar vehicles in the fleet . . .
9. *Annual Insurance Cost:* The estimated cost of insuring the vehicle should be based on past experience with similar vehicles.
10. *Other Miscellaneous Annual Costs:* Any special, recurring costs which may apply to specific vehicles, including the operating costs associated with optional equipment, such as [that] described in the manual sections on vehicle procurement, should be included.

Step 2: Estimate Annual Operating Costs

The annual operating cost of a vehicle can be estimated using the information from a completed Worksheet [1]. To facilitate the computation of this estimated cost, Worksheet [2] provides a step-by-step calculation procedure. Simply follow the sequence of instructions to arrive at the annual operating cost in line 9. If one or more of the optional costs from Worksheet [1] (lines 8-10) have not been estimated, enter them as zeros in Worksheet [2].

Step 3: Determine Present Value of Future Operating Costs and Salvage Value

Using information from Worksheets [1] and [2], a discounted operating cost is calculated for the entire life of the vehicle in the fleet. Using Worksheet [3], the discounted salvage value of the vehicle is then deducted from this cost to arrive at a net vehicle-operating cost. Follow the sequence of eleven instructions in Worksheet [3] to perform these calculations.

Step 4: Compute Life-Cycle Cost

The life-cycle cost of a vehicle is the sum of the purchase price and the net vehicle-operating cost, as calculated in Worksheet [3]. When comparing two or more competing bids for municipal vehicle purchase, the life-cycle costs of each alternative should be compared directly and the lowest selected, unless one of the alternatives has been considered for a different lifetime in the fleet. If this occurs, the life-cycle cost of each alternative should be divided by its assumed lifetime to arrive at an average annual life-cycle cost. These averages can then be compared, with the lowest alternative being selected for purchase.

Worksheet [4] is provided to guide the reader through the final step of calculating the life-cycle cost of a vehicle using the purchase price and assumed life from Worksheet [1], and the net vehicle operating cost from Worksheet [3] . . .

Source: Reference 64.

WORKSHEET [1]

LIFE-CYCLE COST DATA

REQUIRED INFORMATION	SOURCES
LINE	
1. \$ <input type="text"/>	• PURCHASE PRICE • DEALER: EQUIPMENT SUPPLIER
2. <input type="text"/> MI	• EXPECTED ANNUAL MILEAGE • DEPARTMENT HEADS
3. <input type="text"/> YRS.	• NUMBER OF YEARS • VEHICLE RECORDS • VEHICLE TO REMAIN IN FLEET
4. \$ <input type="text"/>	• EXPECTED RESALE (SALVAGE) VALUE OF VEHICLE AT RETIREMENT • DEALER ESTIMATE • DEPARTMENT HEADS • VEHICLE RECORDS
5. <input type="text"/> %	• DISCOUNT RATE • LOCAL POLICY
6. <input type="text"/> MPG	• VEHICLE FUEL ECONOMY • EPA MILEAGE RATING (CITY)
7. \$ <input type="text"/>	• PRICE OF FUEL PER GALLON • LOCAL FUEL DEALER
OPTIONAL INFORMATION	
8. \$ <input type="text"/>	• EXPECTED ANNUAL MAINTENANCE COST • VEHICLE RECORDS
9. \$ <input type="text"/>	• ANNUAL INSURANCE COST • VEHICLE RECORDS
10. \$ <input type="text"/>	• OTHER ANNUAL COST • VEHICLE RECORDS

WORKSHEET [2]

ANNUAL OPERATING COSTS

1. ENTER THE EXPECTED ANNUAL MILEAGE (LINE 2, WORKSHEET [1])	<input type="text"/> MI
2. ENTER THE PRICE OF FUEL PER GALLON (LINE 7, WORKSHEET [1])	X <input type="text"/> \$
3. MULTIPLY AND ENTER THE RESULT	<input type="text"/>
4. ENTER THE FUEL ECONOMY OF THE VEHICLE IN MILES PER GALLON (LINE 6, WORKSHEET [1])	<input type="text"/> MPG
5. DIVIDE THE RESULT IN LINE 3 BY THE FUEL ECONOMY IN LINE 4 AND ENTER THE RESULT	<input type="text"/> \$
6. ENTER THE ANNUAL MAINTENANCE COST (LINE 8, WORKSHEET [1])	<input type="text"/> \$
7. ENTER THE ANNUAL INSURANCE COST (LINE 9, WORKSHEET [1])	<input type="text"/> \$
8. ENTER MISCELLANEOUS ANNUAL COST (LINE 10, WORKSHEET [1])	<input type="text"/> \$
9. ADD THE COST OF LINES 5-8 AND ENTER THE RESULT	<hr/> <input type="text"/> \$
	ANNUAL OPERATING COST

WORKSHEET [3]

PRESENT WORTH OF FUTURE OPERATING COSTS AND SALVAGE VALUE

1. ENTER THE NUMBER OF YEARS THE VEHICLE IS TO REMAIN IN THE FLEET
(LINE 3, WORKSHEET [1]) YRS

2. ENTER THE ACCEPTABLE DISCOUNT RATE (LINE 5, WORKSHEET [1]) %

3. SELECT AN OPERATING COST DISCOUNT FACTOR IN TABLE A USING THE VALUES SPECIFIED IN LINES 1 AND 2.

4. ENTER THE APPROPRIATE DISCOUNT FACTOR FROM TABLE A

5. ENTER THE ANNUAL OPERATING COST (LINE 9, WORKSHEET [2]) X \$

6. MULTIPLY LINES 4 AND 5 AND ENTER THE RESULT \$ **TOTAL OPERATING COST**

7. SELECT A SALVAGE VALUE DISCOUNT FACTOR IN TABLE B USING THE VALUES SPECIFIED IN LINES 1 AND 2

8. ENTER THE APPROPRIATE SALVAGE VALUE DISCOUNT FACTOR FROM TABLE B

9. ENTER THE RESALE VALUE OF THE VEHICLE (LINE 4, WORKSHEET [1]) X \$

10. MULTIPLY LINES 8 AND 9 AND ENTER THE RESULT \$ **DISCOUNTED SALVAGE VALUE**

11. SUBTRACT THE DISCOUNTED SALVAGE VALUE (LINE 10) FROM THE TOTAL OPERATING COST (LINE 6) AND ENTER THE RESULT \$ **NET VEHICLE OPERATING COST**

**TABLE A
DISCOUNT RATE**

YR	3%	4%	5%	8%	10%
1	0.971	0.962	0.952	0.926	0.909
2	1.913	1.866	1.859	1.783	1.736
3	2.829	2.755	2.723	2.577	2.487
4	3.717	3.630	3.546	3.312	3.170
5	4.580	4.452	4.329	4.623	3.791
6	5.417	5.242	5.076	5.206	4.355
7	6.230	6.002	5.786	5.747	4.868

**TABLE B
DISCOUNT RATE**

YR	3%	4%	5%	8%	10%
1	.9709	.9615	.9524	.9259	.9091
2	.9426	.9246	.9570	.8573	.8264
3	.9151	.8890	.8638	.7938	.7513
4	.8885	.8548	.8227	.6806	.6830
5	.8626	.8219	.7835	.6302	.6209
6	.8375	.7903	.7462	.5835	.5645
7	.8131	.7599	.7107	.5403	.5131

WORKSHEET [4]

COMPUTE LIFE-CYCLE COST

1. ENTER THE PURCHASE PRICE OF THE VEHICLE (LINE 1, WORKSHEET [1])	\$ <input type="text"/>	
2. ENTER THE NET VEHICLE OPERATING COST (LINE 11, WORKSHEET [3])	\$ <input type="text"/>	
3. ADD LINES 1 AND 2 AND ENTER THE RESULT	\$ <input type="text"/>	LIFE CYCLE COST
(OPTIONAL)		
4. ENTER THE NUMBER OF YEARS VEHICLE IS TO REMAIN IN FLEET YRS	<input type="text"/> YRS	
5. DIVIDE LINE 3 BY LINE 5 AND ENTER THE RESULT	\$ <input type="text"/>	
		AVERAGE ANNUAL LIFE CYCLE COST

APPENDIX G

SMALL TRANSIT BUS PROFILES

This appendix contains basic design specifications of small transit buses. Although the focus of this report is small transit vehicles, it is useful to have information about all sized vehicles when choosing a vehicle. See: *New Bus Equipment: An Overview of the UMTA Program to Introduce Innovative Transit Buses*, January 1981, UMTA-MA-06-0013-80-1

In the small bus category are heavy-duty transit buses under 35 feet in length with seating capacity for 15 to 35 passengers. During the 1970's, utilization of these vehicles increased dramatically in small urban areas where ridership is lower. These smaller transit vehicles are used for special needs, subscription, charter, airport/mall shuttle, and feeder services.

This appendix contains examples of small buses which are currently available, or which manufacturers claim are at an advanced stage of production design and could be purchased or leased in quantity within the near future. The examples are intended to be representative and do not constitute a complete list of available vehicles.

SMALL TRANSIT BUS

Bluebird Citybird 77CB PP2904



Bluebird claims that its Citybird 2904 has been developed using the best available basic components in a straight forward design. In keeping with this design philosophy, the Citybird has a rear diesel engine contained in a "cradle mounted" assembly with the transmission, radiator, and exhaust systems. The manufacturer maintains that the complete assembly can be withdrawn from the vehicle and refitted in four hours. Standard features include air ride suspension, air

brakes, integral power steering, full open sliding windows, and air conditioning. Sales, warranty, service and parts are handled directly by the Bluebird factory in an attempt to remain easily accessible and responsive to operators. Each purchaser of Bluebird units is entitled to send two service personnel to a factory-sponsored, 40-hour maintenance school. The Bluebird Body Company estimates the Citybird's lifespan to be 10 to 12 years.

MANUFACTURER

BLUEBIRD BODY COMPANY
P.O. Box 937
Fort Valley, Georgia 31030

DESIGN SPECIFICATIONS

Dimensions	
Length	– 31.14 ft.
Width	– 96 in. (excluding mirrors and opened doors)
Height	– 115.5 in. (overall)
Wheelbase	– 180 in.
Turning Radius	– 33 ft. (from outside body corner)
Passenger Capacity	
Seated	– 31 Passengers
Standees	– 20 Passengers
Curb Weight	– 19,410 lbs.
Gross Vehicle Weight	– 27,000 lbs.
Tire Size	– 10 x 20 tube type
Propulsion System	– DDA 6V-53 turbo charged
Suspension	– Air
Passenger Windows	– Sliding and push out
Air Conditioning	– Standard – Thermo King DIM6A
Floor Height	– 34 in. (at kneeled position – 28 in.)
Step Height	
Ground to First	– 14 in.
First to Second	– 10 in.
Second to Floor	– 10 in.
Door Opening Widths (clear openings)	
Front	– 28 in.
Rear	– 34 in.
Options for the Mobility Impaired	
Kneeler	
Wheelchair Lift by Collins Industries	
Wheelchair Restraints	



SMALL TRANSIT BUS

Chance RT-50



The Chance RT-50 is a heavy-duty small bus which adheres to large bus design practices. As a result, air brakes, air suspension, and a diesel engine are standard. Advanced bus design features such as low floors and extra large side windows are also incorporated into the design and the double-wide entrance/exit doorway is standard equipment. Aircraft-type fasteners are used on the skirt panels to facilitate expedient replacement. The manufacturer claims that

support components have been selected to meet strict requirements for quality and market availability. The standard configuration includes a front-mounted engine, 12/24 dual-voltage electrical system featuring quick disconnect sectional harnesses, color-coded air line system and semi-pneumatic anti-ride bumpers. A drive line brake retarder by Telma is optional. The manufacturer's estimate of lifespan for this vehicle is 10 to 15 years.

DESIGN SPECIFICATIONS

Dimensions	
Length	— 26.5 ft.
Width	— 96 in. (excluding mirrors and opened doors)
Height	— 120 in. (overall)
Wheelbase	— 168 in.
Turning Radius	— 28.5 ft. (from outside body corner)
Passenger Capacity	
Seated	— 25 passengers
Standees	— 15 passengers
Curb Weight	— 14,500 lbs.
Gross Vehicle Weight	— 22,000 lbs.
Tire Size	— GVR 9 x 22.5 tubeless
Propulsion System	— Caterpillar Diesel 3208-175 (V8)
Suspension	— Air
Passenger Windows	— 5 fixed and 4 sliding
Air Conditioning	— Standard — Thermo King BI-M15
Floor Height	— 32 in. (at kneeled position — 29 in.)
Step Height	
Ground To First	— 14 in.
First To Second	— 9 in.
Second To Floor	— 9 in.
Door Opening Widths (Clear Openings)	
Front	— 48 in.
Options for the Mobility Impaired	
Kneeler	
Wheelchair Lift by Vapor Corp.	
Wheelchair Restraints	

MANUFACTURER
CHANCE MANUFACTURING COMPANY
1103 Ross Avenue, Dept. R
Dallas, Texas 75202



SMALL TRANSIT BUS

TMC Citycruiser T-30



The Citycruiser T-30 is a small heavy-duty transit bus designed specifically for mass transit operations. Included as standard equipment are air suspension, heavy-duty air brake system, rear mounted diesel engine, power steering, tilt steering wheel, rear vertical exhaust, 90-gallon fuel tank, three-way adjustable roof ventilators, and double-glazed windows. A test circuit is provided on the control panel to verify operation of all telltale warning lights. A wide variety

of seat styles and configurations is also available. The rear axle has wide spaced air springs for added stability. The front door is of the one-piece type, providing superior sealing capabilities against weather. The rear exit features a "sensitive treadle" controlled by a driver's lock mechanism that opens the door when a passenger stands on either step. Field technical representatives are available for troubleshooting.

DESIGN SPECIFICATIONS

Dimensions	
Length	— 31.67 ft.
Width	— 96 in. (excluding mirrors and opened doors)
Height	— 114 in. (overall)
Wheelbase	— 180 in.
Turning Radius	— 33 ft. (from outside body corner)
Passenger Capacity	
Seated	— 31 passengers
Standees	— 30 passengers (1 ½ square feet per passenger)
Curb Weight	— 19,800 lbs.
Gross Vehicle Weight	— 33,200 lbs.
Tire Size	— 10 x 20 tube type
Propulsion System	— DDA 6V-53T
Suspension	— Air
Passenger Windows	— 8 fixed
Air Conditioning	— Optional — Carrier, 70,000 BTU/HR.
Floor Height	— 34 in. (at kneeled position — 29.5 in.)
Step Height	
Ground To First	— 14 in.
First To Second	— 10 in.
Second To Floor	— 10 in.
Door Opening Widths (Clear Openings)	
Front	— 31 in.
Rear	— 31 in.
Options for the Mobility Impaired	
Kneeler	
Wheelchair Lift	
Wheelchair Restraints	

MANUFACTURER
TRANSPORTATION MANUFACTURING CORP.
c/o Hausman Bus Sales
505 North Lake Shore Drive
Suite 6106
Chicago, Illinois 60611

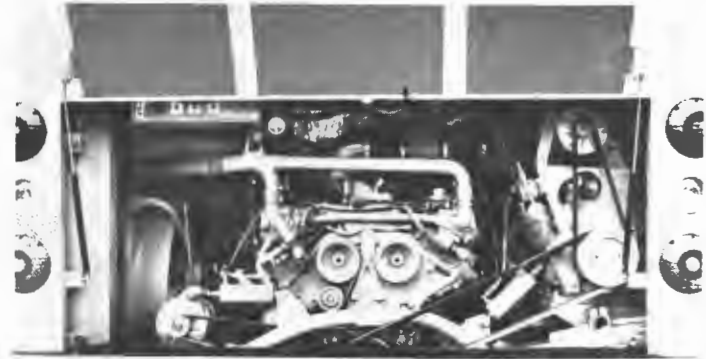

SMALL TRANSIT BUS

Skillcraft Transmaster L31



The Skillcraft Transmaster L31 is a small diesel-powered heavy-duty transit bus designed to meet UMTA's 1976 small bus performance specifications. The Transmaster features a low floor that incorporates a manual wheelchair ramp as standard equipment. This driver-operated ramp maintains a 14° angle to the ground and an 11° angle to a 9-inch curb. The engine and transmission are mounted side-by-side, coupled with a special transfer case. This engine mounting design has been combined with a very large engine

compartment, resulting in a high degree of maintenance accessibility. Consequently, Skillcraft claims that down time required for normal repair and maintenance procedures is reduced by 15 percent. A dual visual-audio diagnostic driver's instrumentation panel is also provided. The Transmaster uses a single door in its standard design. However, a version with an additional door and reduced seating capacity is available as an option. Manufacturer's estimated lifespan for the vehicle is 12 to 15 years.

MANUFACTURER

SKILLCRAFT INDUSTRIES
1270 Ogden Road
Venice, Florida 33595

DESIGN SPECIFICATIONS

Dimensions	
Length	– 32.5 ft.
Width	– 96 in. (excluding mirrors and opened doors)
Height	– 99 in. (overall)
Wheelbase	– 252 in.
Turning Radius	– 36 ft. (from outside body corner)
Passenger Capacity	
Seated	– 31 passengers
Standees	– 19 passengers (1 ½ square feet per passenger)
Curb Weight	– 16,000 lbs.
Gross Vehicle Weight	– 24,000 lbs.
Tire Size	– 8R 22.5
Propulsion System	– DDA 453T or 8.2 liter turbo charged
Suspension	– Leaf spring
Passenger Windows	– Upper fixed and lower sliding
Air Conditioning	– Standard – Thermo King 5 ton
Floor Height	– 19 in.
Step Height	
Ground To First	– 11 in.
First To Floor	– 8 in.
Door Opening Widths (Clear Openings)	
Front	– 35 in.
Options for the Mobility Impaired	
Wheelchair Manual Ramp	
Wheelchair Restraints	

SMALL TRANSIT BUS

Steyr City-Bus



The Steyr City-Bus is a small transit bus which uses front wheel drive and thus allows a continuous 12-inch low floor. Its low floor, standard driver-operated manual wheelchair ramp, and standard 49-inch clear door opening indicate that this vehicle has been designed to facilitate transit service for the mobility impaired. The manufacturer claims that the front wheel drive, combined with four wheel independent

suspension gives the Steyr City-Bus extra handling ability in snow. The engine transmission assembly is front mounted to the vehicle by only three bolts, facilitating easy removal. Steyr maintains that this engine will achieve 15 to 16 miles per gallon and estimates the vehicle's lifespan to be 10 to 12 years. The body is constructed of laminated fiberglass.

U.S. DISTRIBUTOR

TRANSBUS OF AMERICA CORPORATION

P.O. Box 1199

299 Warren Avenue

Portland, Maine 04103

DESIGN SPECIFICATIONS

Dimensions	
Length	— 19 ft.
Width	— 80 in. (excluding mirrors and opened doors)
Height	— 98.5 in. (overall)
Wheelbase	— 129.9 in.
Turning Radius	— 21.75 ft. (from outside body corner)
Passenger Capacity	
Seated	— 15 passengers
Standees	— 13 passengers (150 lbs. per passenger)
Curb Weight	— 5,700 lbs.
Gross Vehicle Weight	— 9,700 lbs.
Tire Size	— 205 R 14
Propulsion System	— Daimler-Benz OM 616 Diesel (4 cylinders)
Suspension	— Front-coil spring/rear-air
Passenger Windows	— Openable segments
Air Conditioning	— Optional — Thermo King B3M7
Floor Height	— 13 in.
Step Height	
Ground To Floor	— 13 in.
Door Opening Widths (Clear Openings)	
Front	— 47.25 in.
Options for the Mobility Impaired	
Manual Wheelchair Ramp (standard)	
Wheelchair Restraints (one (1) standard, additional restraints optional)	
Suspension	— Front-coil spring/rear-air (4 wheel independent)

