

57-03 17-8

Report No. UMTA-CA-06-0088-82-1

AUTOMATED MIXED TRAFFIC VEHICLE SYSTEM DESIGN AMTV II

Alan R. Johnston
Richard A. Marks
Paul L. Cassell

Jet Propulsion Laboratory
California Institute of Technology
Pasadena, California
(JPL Publication 82-58)



January 1982

Final Report

This document is available to the U.S. public through the
National Technical Information Service
Springfield, Virginia 22161

Prepared for

U.S. DEPARTMENT OF TRANSPORTATION

MTA LIBRARY

of Technology Development and Deployment
San Mass Transportation Administration
Washington, D.C. 20590

TL
220
.J65

NOTICES

This document was prepared by the Jet Propulsion Laboratory, California Institute of Technology, and was sponsored by the U.S. Department of Transportation through an agreement with the National Aeronautics and Space Administration. (NASA RD-152, Amendment 198.)

This document is disseminated under the sponsorship of the Department of Transportation in the interest of information exchange. The United States Government assumes no liability for the contents or use thereof.

The United States Government does not endorse products or manufacturers. Trade or manufacturer's names appear herein solely because they are considered essential to the object of this report.

TL
220
14948 .J65

JUN 08 '83

Technical Report Documentation Page

1. Report No. UMTA-CA-06-0088-82-1		2. Government Accession No.		3. Recipient's Catalog No.	
4. Title and Subtitle Automated Mixed Traffic Vehicle System Design AMTV II				5. Report Date January 1982	
				6. Performing Organization Code	
7. Author(s) Alan R. Johnston, Richard A. Marks				8. Performing Organization Report No. JPL Publication 82-58	
9. Performing Organization Name and Address Jet Propulsion Laboratory California Institute of Technology 4800 Oak Grove Dr., Pasadena, CA 91109				10. Work Unit No. (TRAIS)	
				11. Contract or Grant No. DOT-AT-60008T	
12. Sponsoring Agency Name and Address U.S. Department of Transportation Urban Mass Transportation Administration 400 7th Street, S.W. Washington, D.C. 20590				13. Type of Report and Period Covered Final Report	
				14. Sponsoring Agency Code UMTA-UTD-42	
15. Supplementary Notes					
16. Abstract The design of an improved and enclosed Automated Mixed Traffic Transit (AMTT) vehicle is described. AMTT is an innovative concept for low-speed tram-type transit in which suitable vehicles are equipped with sensors and controls to permit them to operate in an automated mode on existing road or walkway surfaces. The vehicle chassis and body design are presented in terms of sketches and photographs. The functional design of the sensing and control system is presented, and modifications which could be made to the baseline design for improved performance, in particular to incorporate a 20-mph capability, are also discussed. The vehicle system is described at the block-diagram-level of detail. Specifications and parameter values are given where available.					
17. Key Words Transit, Automation, Tram, Cable-follower, Vehicle Controller, Optical Sensor			18. Distribution Statement Available to the Public Through the National Technical Information Service Springfield, Virginia 22161		
19. Security Classif. (of this report) Unclassified		20. Security Classif. (of this page) Unclassified		21. No. of Pages 70	22. Price

Form DOT F 1700.7 (8-72)

MTA LIBRARY

METRIC CONVERSION FACTORS

Approximate Conversions to Metric Measures

Symbol	When You Know	Multiply by	To Find	Symbol
LENGTH				
in	inches	*2.5	centimeters	cm
ft	feet	30	centimeters	cm
yd	yards	0.9	meters	m
mi	miles	1.6	kilometers	km
AREA				
in ²	square inches	6.5	square centimeters	cm ²
ft ²	square feet	0.09	square meters	m ²
yd ²	square yards	0.8	square meters	m ²
mi ²	square miles	2.6	square kilometers	km ²
	acres	0.4	hectares	ha
MASS (weight)				
oz	ounces	28	grams	g
lb	pounds	0.45	kilograms	kg
	short tons (2000 lb)	0.9	tonnes	t
VOLUME				
tap	teaspoons	5	milliliters	ml
Tbsp	tablespoons	15	milliliters	ml
fl oz	fluid ounces	30	milliliters	ml
c	cups	0.24	liters	l
pt	pints	0.47	liters	l
qt	quarts	0.95	liters	l
gal	gallons	3.8	liters	l
ft ³	cubic feet	0.03	cubic meters	m ³
yd ³	cubic yards	0.76	cubic meters	m ³
TEMPERATURE (exact)				
°F	Fahrenheit temperature	5/9 (after subtracting 32)	Celsius temperature	°C

*1 in. = 2.54 (exactly). For other exact conversions and more detail on tables, see NBS Monograph 286, Units of Weights and Measures, Page 52-55, SD Catalog No. 113-113-086.

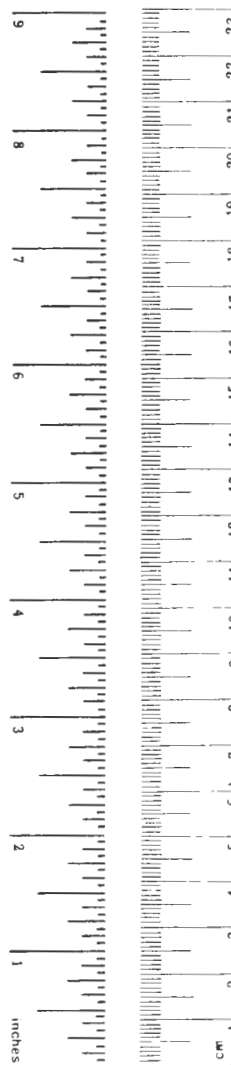

Approximate Conversions from Metric Measures

Symbol	When You Know	Multiply by	To Find	Symbol
LENGTH				
mm	millimeters	0.04	inches	in
cm	centimeters	0.4	inches	in
m	meters	3.3	feet	ft
m	meters	1.1	yards	yd
km	kilometers	0.6	miles	mi
AREA				
cm ²	square centimeters	0.16	square inches	in ²
m ²	square meters	1.2	square yards	yd ²
km ²	square kilometers	0.4	square miles	mi ²
ha	hectares (10,000 m ²)	2.5	acres	
MASS (weight)				
g	grams	0.035	ounces	oz
kg	kilograms	2.2	pounds	lb
t	tonnes (1000 kg)	1.1	short tons	
VOLUME				
ml	milliliters	0.03	fluid ounces	fl oz
l	liters	2.1	pints	pt
l	liters	1.06	quarts	qt
l	liters	0.26	gallons	gal
m ³	cubic meters	35	cubic feet	ft ³
m ³	cubic meters	1.3	cubic yards	yd ³
TEMPERATURE (exact)				
°C	Celsius temperature	9/5 (then add 32)	Fahrenheit temperature	°F

ACKNOWLEDGMENTS

The authors acknowledge the important contributions of a number of other individuals to the development of AMTV II. Special thanks are due to Ed Koch for the hydraulic system design and to Mark Nelson for initial work on the focal plane array headway sensor concept. The considerable assistance and continued support of Gerald W. Meisenholder is also gratefully acknowledged, as is the interest and technical contributions of Robert Hoyler and Duncan MacKinnon at the Urban Mass Transportation Administration, U.S. Department of Transportation.

MTA LIBRARY

CONTENTS

1.	INTRODUCTION	1-1
2.	VEHICLE CHASSIS AND BODY DESIGN	2-1
2.1	APPROACH	2-1
2.2	TRAM CHASSIS	2-2
2.3	BODY DESIGN	2-2
3.	SENSING AND CONTROL SYSTEM DESIGN	3-1
3.1	ELECTRONIC CONTROL UNIT	3-4
3.1.1	Functional Description	3-4
3.1.2	External Interfaces	3-7
3.2	HEADWAY SENSOR SYSTEM	3-7
3.2.1	Functional Description	3-7
3.2.2	Interfaces	3-18
3.2.3	Specifications and Parameter Values	3-20
3.3	MANUAL CONTROLLER	3-21
3.3.1	Functional Description	3-21
3.3.2	Interfaces	3-21
3.4	INDICATOR PANEL	3-22
3.4.1	Functional Description	3-22
3.5	SWITCH INPUTS	3-23
3.5.1	Functional Description	3-23
3.5.2	Interfaces	3-24
3.6	ROAD MARKER SENSOR	3-25
3.6.1	Functional Description	3-25
3.6.2	Interfaces	3-25
3.6.3	Specifications and Parameters	3-26

3.7	STEERING SENSOR	3-26
3.7.1	Functional Description	3-27
3.7.2	Interfaces	3-27
3.7.3	Specifications and Parameter Values . .	3-28
3.8	HYDRAULIC SYSTEM	3-29
3.8.1	Functional Description	3-29
3.8.2	Interfaces	3-32
3.8.3	Specifications	3-32
3.9	INTERFACE UNIT	3-32
3.9.1	Functional Description	3-32
3.9.2	Interfaces	3-33
3.10	MOTOR CONTROLLER	3-34
3.10.1	Functional Description	3-35
3.10.2	Interfaces	3-35
3.10.3	Specifications and Parameter Values . .	3-36
3.11	SPRING BRAKE	3-36
3.11.1	Functional Description	3-36
3.11.2	Specifications	3-36
3.12	U-TURN SENSOR	3-37
3.12.1	Functional Description	3-37
3.12.2	Interfaces	3-37
3.13	WIRE EXCITER	3-38
3.13.1	Functional Description	3-38
3.13.2	Interfaces	3-38
3.13.3	Specifications and Parameter Values . .	3-38
4.	FUTURE ADDITIONS	4-1
4.1	20-MPH CAPABILITY	4-1

4.1.1	0- to 7-mph Capability	4-2
4.1.2	7- to 10-mph Capability	4-5
4.1.3	10- to 15-mph Capability	4-5
4.1.4	15- to 20-mph Capability	4-5
4.2	LONG-RANGE HEADWAY SENSORS	4-6
4.3	STEERING SERVO UPGRADE	4-6
4.4	FAIL-SAFE DESIGN ADDITIONS	4-7
4.4.1	Dual Microprocessors	4-7
4.4.2	Dual Steering Sensors	4-7
4.4.3	Fail-Safe Road Marker Signals	4-7
4.4.4	Sudden Hard-Over Steering Failure Detection	4-7
4.5	COMPLIANT BUMPER-SWITCH	4-7
5.	CONCLUSIONS	5-1
6.	REFERENCES	6-1

Figures

1-1.	THE AMTV II CURRENTLY UNDER DEVELOPMENT, WITH THE ORIGINAL AMTV BEHIND IT	1-2
2-1.	THE COMMERCIAL TRAM USED AS THE CHASSIS FOR AMTV II	2-5
2-2.	PERIMETER CHASSIS FRAME FOR BODY BUILD-UP	2-6
2-3.	SKETCH OF THE AMTV II BODY	2-7
2-4.	VEHICLE ARCHITECTURE	2-8
2-5.	A REAR VIEW OF AMTV II	2-9
2-6.	THE INTERIOR AT THE FRONT OF AMTV II	2-10
2-7.	THE AMTV II INTERIOR LOOKING TOWARD THE REAR	2-11
3-1.	LOCATION OF THE AMTV II SYSTEM COMPONENTS	3-2

Figures (Cont'd)

3-2.	AMTV II CONTROL SYSTEM, INTERCONNECTION ROUTING	3-3
3-3.	ELECTRONIC CONTROL UNIT INTERFACES	3-14
3-4.	THE DETECTION AREAS OF THE HEADWAY SENSING SYSTEM FOR A BLACK TARGET AND FOR A RETROREFLECTIVE TARGET	3-20
3-5.	THE CONCEPT USED FOR PROPORTIONAL ACTUATION OF THE HYDRAULIC SERVICE BRAKES	3-31
4-1.	POWER SCHEMATIC FOR SWITCHING BETWEEN 0- TO 7-MPH MODE AND 7- TO 20-MPH MODE	4-3
4-2.	A PROPOSED DESIGN FOR A COMPLIANT CONTACT BUMPER SWITCH	4-9

Tables

2-1.	SPECIFICATIONS OF ELECTRIC TRAM CHASSIS	2-3
2-2.	DESIGN REQUIREMENTS FOR AMTV II BODY	2-4
3-1.	SIGNALS INPUT TO THE ECU FROM VARIOUS SENSORS	3-8
3-2.	SIGNALS OUTPUT FROM THE ECU TO SENSORS OR ACTUATORS	3-11
3-3.	POWER SUPPLY OR EXCITATION VOLTAGES INPUT TO ECU	3-13
3-4.	POWER OR EXCITATION VOLTAGE PROVIDED BY ECU TO SENSORS OR SWITCHES	3-13

SECTION 1

INTRODUCTION

This report describes the design of an automated wire-following tram which has been under development at the Jet Propulsion Laboratory (JPL) for the Urban Mass Transportation Administration of the U.S. Department of Transportation. The vehicle, which will be termed AMTV II in this report, is an improved and enclosed version of an earlier "breadboard" Automated Mixed Traffic Vehicle (AMTV I). It is intended for use in tests and demonstrations aimed toward proving the ultimate practicability of a transportation system based on similar vehicles.

The system concept, called Automated Mixed Traffic Transit (AMTT) is an innovative transit option which will be useful at sites where a low-speed tram-type service is needed. AMTT is a cost-effective option because costs for the driver dominate in a conventional bus system, and guideway costs dominate in an exclusive right-of-way Automated Guideway Transit (AGT) system. Neither of these cost elements will be present in an AMTT system.

Investigation of AMTT began at JPL in 1975, drawing on results from earlier work in transportation systems and sensor technology. The breadboard vehicle, AMTV I, was built and operated in an experimental mode in mixed traffic on a guide wire loop route at JPL (Reference 1). Figure 1-1 shows the original vehicle, AMTV I, alongside the new vehicle, AMTV II, still under



FIGURE 1-1. THE AMTV II, CURRENTLY UNDER DEVELOPMENT, WITH THE ORIGINAL AMTV BEHIND IT

development. Since that time, work on AMTT technology has continued at JPL with system studies (References 2, 3, and 4); hazard and failure analyses (References 4, 5, and 6); safety design (Reference 7); studies of sensing technology (Reference 5); development of a programmable microprocessor vehicle controller (Reference 6); and a scheduling study (Reference 8). A number of detailed investigations of AMTT applications (References 9 through 14) and a sensing technology study (Reference 15) have been performed at other laboratories during the same period. In addition to the development of AMTV II, application site studies (Reference 16), a liability study (Reference 17) and an AMTT workshop (Reference 18) were conducted and reported on as part of our current task.

The purpose of the AMTT development effort was to build a reliable, low-cost, low-speed automated tram and demonstrate it in an appropriately constrained vehicle-pedestrian traffic mix. Initial demonstration efforts would be in a pedestrian-only environment. The degree of restriction and the type of interacting traffic that are appropriate for an AMTT system are not yet well known, and thus, are prime subjects for investigation during system tests and demonstrations. In support of this general goal, a portion of the current work addressed the development of critical AMTV technology such as improved sensors, safety, reliability, and control techniques. This work has been accomplished by utilizing the results of previous work at JPL, including the original breadboard vehicle.

Section 2 of this report describes the approach taken in building the vehicle chassis and body. Sketches and photographs are shown to illustrate its appearance and configuration. Section 3 discusses the design of the sensing and control system of AMTV II, and describes subsystems and their interfaces. Section 4 outlines certain additions or modifications to the basic system design, which have been investigated and defined in a preliminary way, but have not been incorporated in the present vehicle. Section 5 presents a brief set of conclusions.

This report describes the present status of the AMTV II design in terms of block diagrams and sketches. It is a functional description of AMTV II in some detail; however, circuit diagrams and shop drawings are beyond the scope of this report.

SECTION 2

VEHICLE CHASSIS AND BODY DESIGN

2.1 APPROACH

The design of AMTV II is developed around a commercial eight-passenger electric tram (Reference 19) which is used for the chassis and running gear. A custom-built fiberglass body was attached to the tram, and new seats and trim were added, resulting in a nicely finished interior. The seating for nine passengers was obtained, rather than eight, because the conventional driver controls and a central console were removed from the front seat area. The addition of a body permitted the use of light automotive-type doors interlocked with the control system, and the inclusion of a windshield equipped with impact switches for added collision protection above the headway sensor field.

This approach was selected for its cost-effectiveness in producing a single test vehicle; it also took advantage of our earlier experience with AMTV I, which was built on a nearly identical electric tram. Disadvantages were a lack of opportunity to minimize the weight of the finished vehicle or to obtain an optimized and integrated chassis design.

The conventional steering wheel, accelerator pedal, and brake, which were left in AMTV I as an override control option both for safety backup and routine manual operation, are omitted in AMTV II. Instead, a hand-held plug-in control box, similar to those used in radio controlled model cars, will be

provided for manual control to move the vehicle from its garage area to the route loop. The observers required for safety backup during early developmental testing and demonstrations will rely on two types of stop buttons provided in the vehicle, as well as a backup toggle pull valve for manual application of the hydraulic service brakes. The observers need not sit in the left front seat.

2.2 TRAM CHASSIS

Specifications for the commercial electric tram are given in Table 2-1, and a photograph is shown in Figure 2-1.

The only significant structural modification made before adding the body shell was to remove the curved sheet-metal vertical front surface of the tram and about 3 in. of the floor immediately behind it. The steering column, pedals, and hand-operated parking brake were removed as part of this operation. According to present plans, the parking-brake handle will be remounted for initial testing but will be removed subsequently to allow unobstructed access to the front seat. Another modification was to install an all-electronic transistor chopper motor controller which will be described more fully in Section 3.

2.3 BODY DESIGN

The general requirements which were placed on the body design are listed in Table 2-2. The earlier study on the safety aspects of body design (see Reference 7) was used as a design guideline.

TABLE 2-1. SPECIFICATIONS OF ELECTRIC TRAM CHASSIS

Seating	Eight passengers on three forward facing seats
Length	130 in.
Width	50 in.
Wheelbase	80 in.
Steering Angle	31 deg maximum
Turning Circle	30 ft (tram only without custom body)
Brakes	4-wheel hydraulic
Tires	5.70 x 8 8-ply on split rim wheels
Motor	5 Hp 36 Vdc
Speed	7 mph on 36-V battery
Battery	12 250 Ah units connected in two 36-V strings of 6 batteries each
Parking Brake	Hand-operated external band-type acting on differential shaft
Weight Empty	2700 lb (estimated)

TABLE 2-2. DESIGN REQUIREMENTS FOR AMTV II BODY

-
1. Body shall provide a semi-enclosed structure with passenger-operated automotive-type doors. Doors shall not include windows.
 2. Doors shall be provided with interlock switches to indicate when each is closed and locked.
 3. Head room shall be 60 in. minimum.
 4. Conventional automotive lighting, turn signals, and brake lights shall be provided.
 5. An automotive-type energy absorbing bumper shall be provided at normal bumper height.
 6. Enclosed space shall be provided for headway sensors behind the front surface of the vehicle, and holes permitting an unobstructed field of view for each unit shall be provided.
 7. Enclosed space shall be provided for control electronics, hydraulic system components, and traction motor controller.
 8. A laminated safety-glass windshield shall be provided. Mounting shall include switches capable of detecting an impact at any point on glass before windshield breaks.
 9. Padding for passenger protection shall be provided at all potential interior impact surfaces.
 10. A contact switch strip shall be provided along both sides and front of the body.
-



FIGURE 2-1. THE COMMERCIAL TRAM USED AS THE CHASSIS FOR AMTV II

Because of the degree of torsional compliance found in the tram chassis, the body shell was mounted as a unit to a perimeter frame built of square steel tubing, shown in Figure 2-2. The perimeter frame was then attached rigidly to the middle section of the tram, flexible rubber fastenings were used at the ends. Structural integrity for the body shell was provided by a welded frame of square steel tubing.

The estimated weight of the finished body was 350 lb. A sketch is shown in Figure 2-3 and a breakdown of the fiberglass panels which make up the body are shown in Figure 2-4. Photographs of AMTV II after the completed body unit was mounted on the tram are shown in Figures 2-5, 2-6, and 2-7.

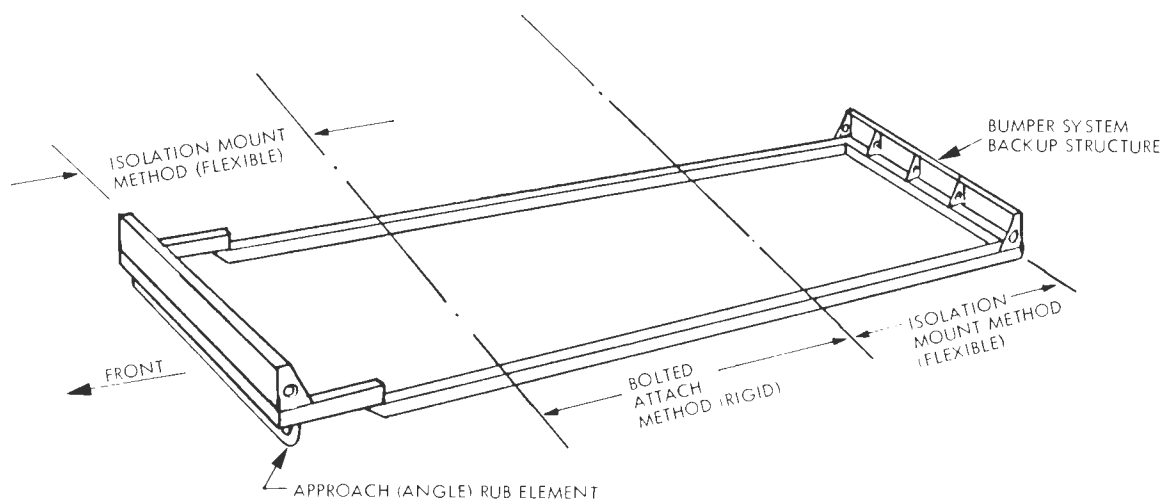

FIGURE 2-2. PERIMETER CHASSIS FRAME FOR BODY BUILD-UP

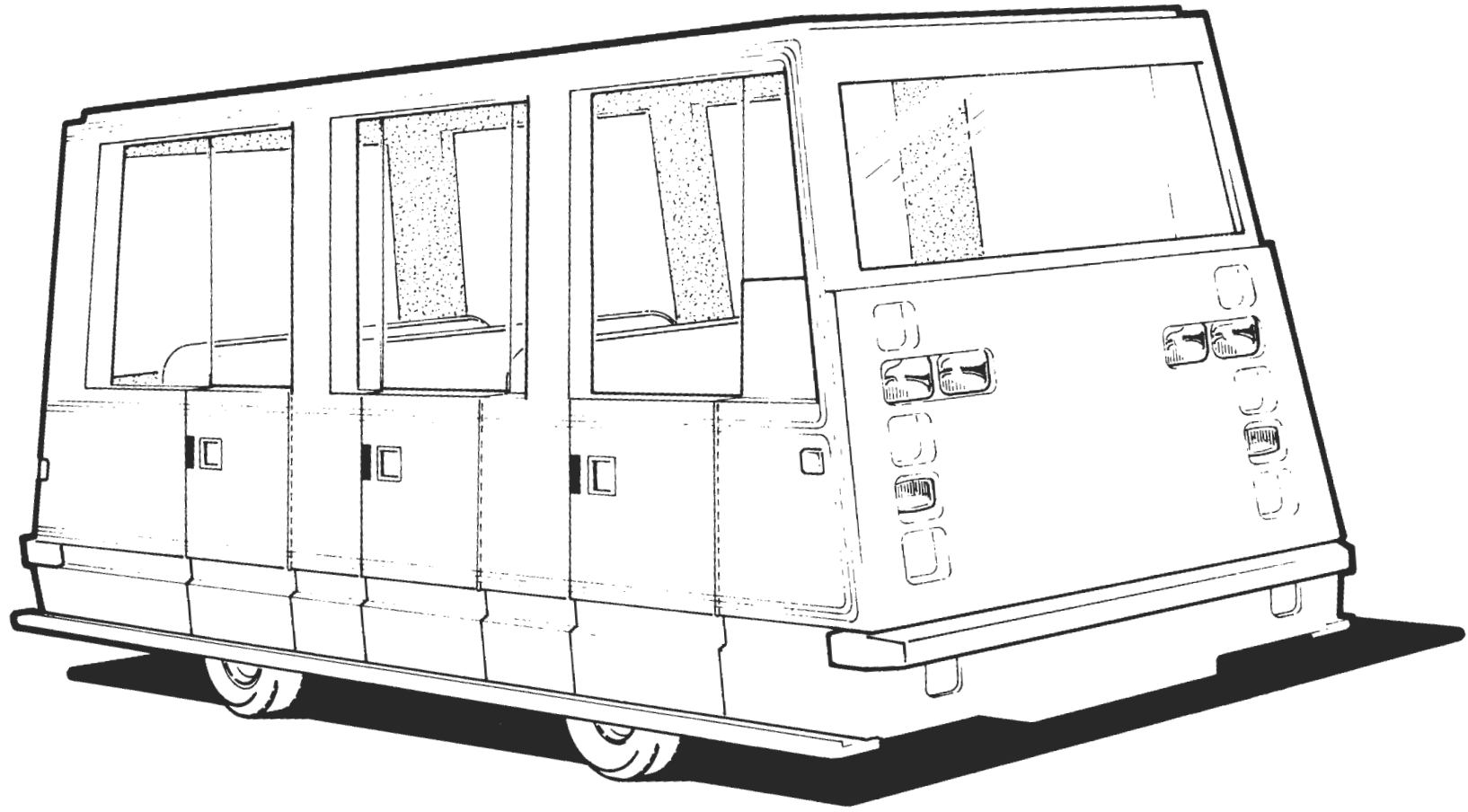

FIGURE 2-3. SKETCH OF THE AMTV II BODY

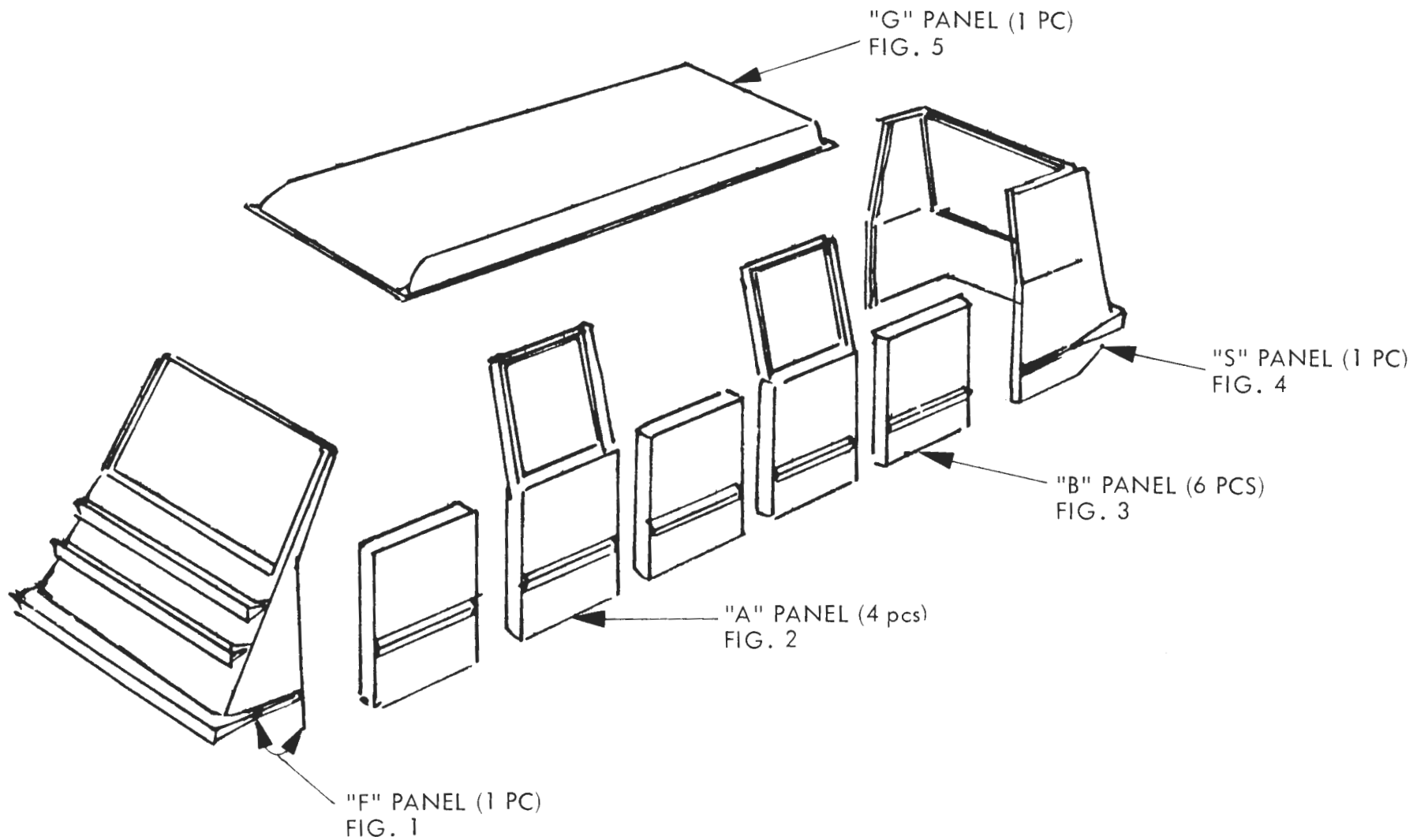

FIGURE 2-4. VEHICLE ARCHITECTURE



FIGURE 2-5. A REAR VIEW OF AMTV II



FIGURE 2-6. THE INTERIOR AT THE FRONT OF AMTV II



FIGURE 2-7. THE AMTV II INTERIOR LOOKING TOWARD THE REAR

SECTION 3

SENSING AND CONTROL SYSTEM DESIGN

This section of the report presents the functional design of the sensing and control system of AMTV II. The earlier vehicle (AMTV I) has been used as a baseline. An informal paper containing much of this material has been in use in our laboratory as a working document for some time, and has undergone several iterations as the development of the AMTV II design progressed. The following material represents the current design status.

The physical location of each of the sensing and control components in the vehicle is shown in Figure 3-1. An enclosed space between the external front surface of the vehicle and a dashboard bulkhead facing the front seat houses the microprocessor, headway sensors, and related equipment. The space under the center seat, which is not limited by the presence of wheel wells, contains one main battery string and the hydraulic system. An enclosed space behind the rear seat houses a second main battery string, and the high-current traction motor control equipment.

The block diagram in Figure 3-2 identifies the subsystems and their interconnections. The interconnections shown are functional; no attempt has been made to show individual signal channels.

Each subsystem is discussed below in terms of: (1) a

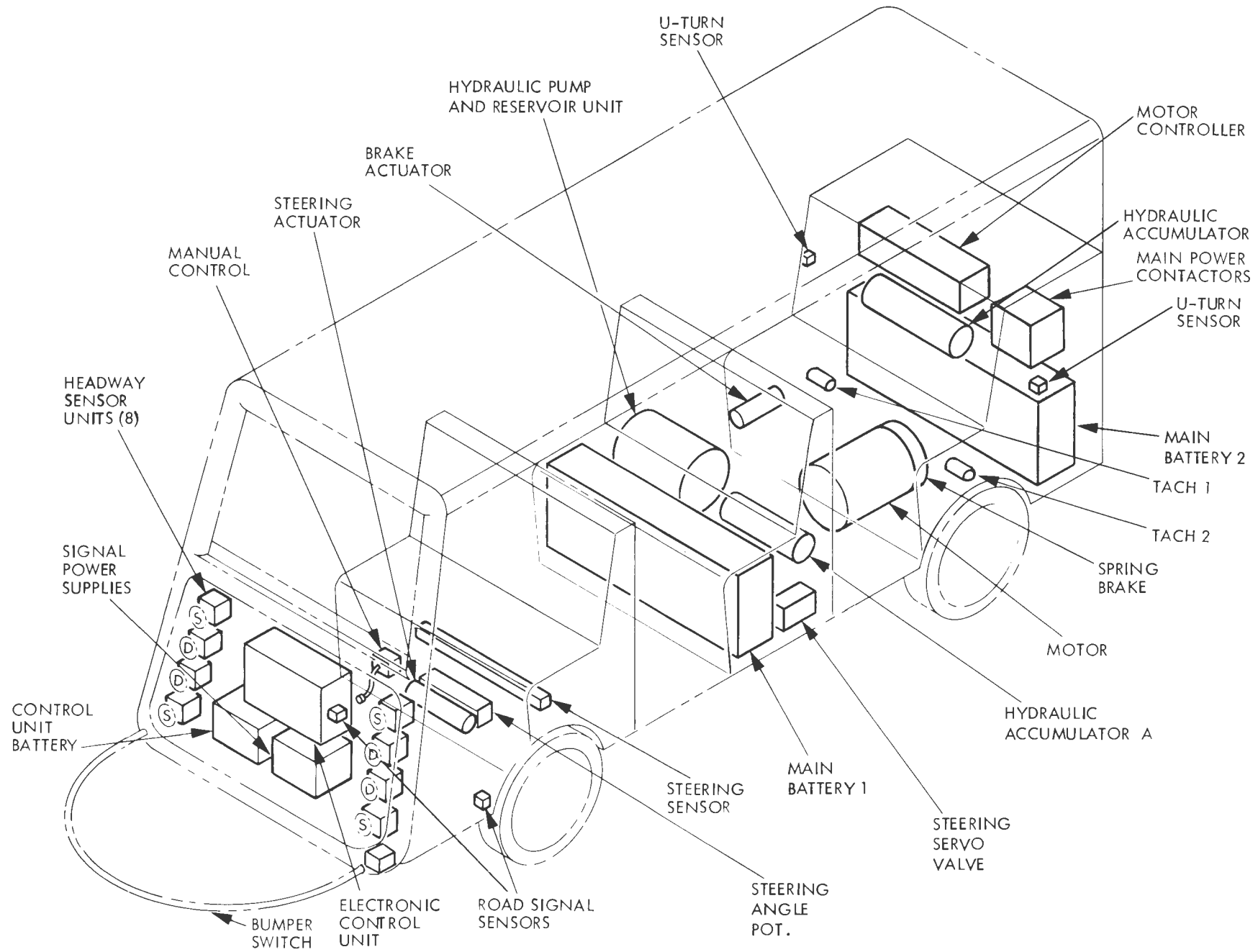

FIGURE 3-1. LOCATION OF THE AMTV II SYSTEM COMPONENTS

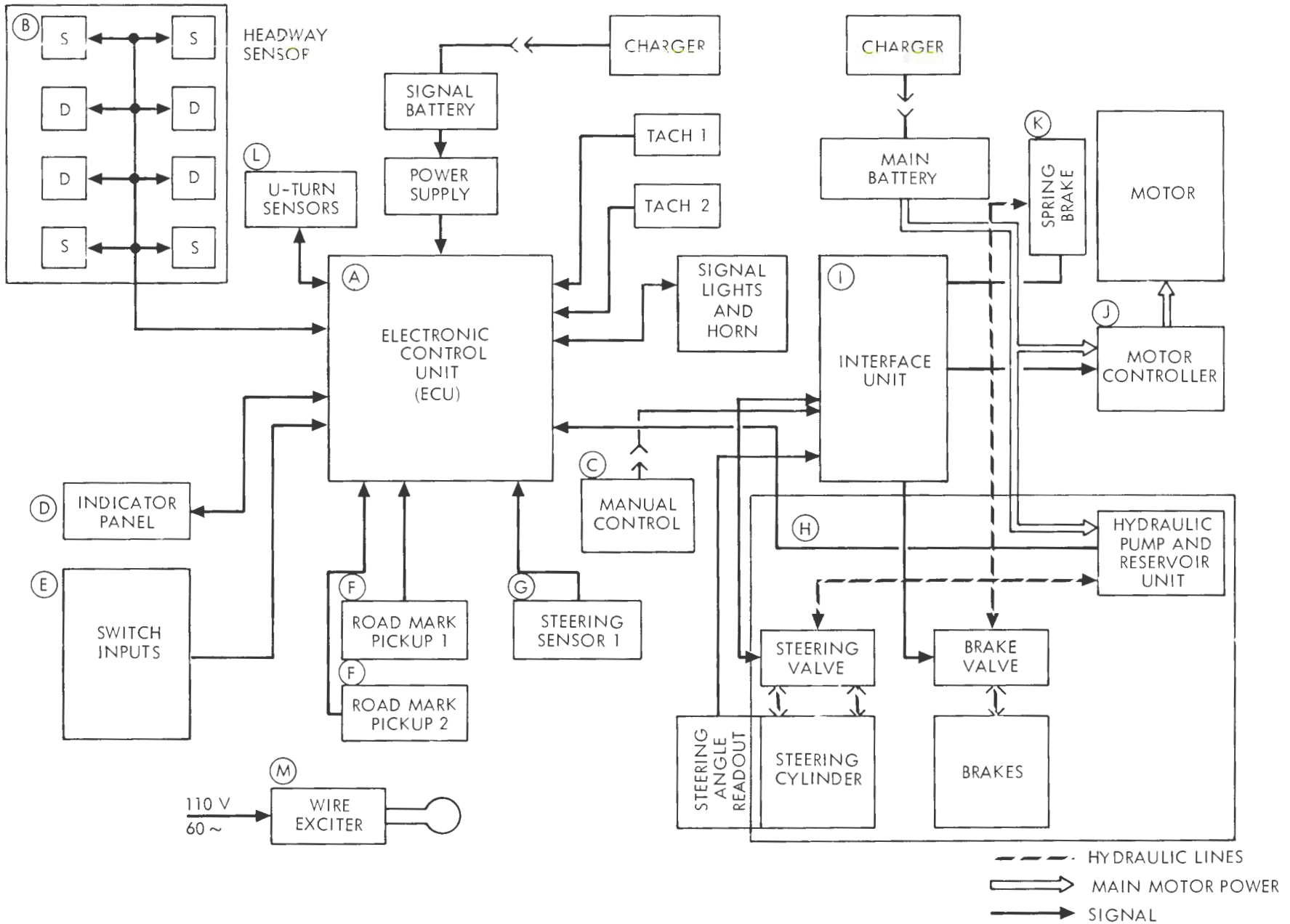

FIGURE 3-2. AMTV II CONTROL SYSTEM, INTERCONNECTION ROUTING

functional description, (2) a definition of its interfaces (inputs and outputs with other subsystems), and (3) quantitative specifications, where they are known. Several simple components indicated on the block diagram, such as horn and turn-signal lights, are not included in the subsystem descriptions.

The capital letter designations used in the succeeding paragraphs designate each subsystem; they are also used on the block diagram to facilitate cross reference. The "sub" prefix has been dropped when describing specific functional blocks (e.g., Headway Sensor System rather than Headway Sensor Subsystem).

3.1 ELECTRONIC CONTROL UNIT (A)

3.1.1 Functional Description

The electronic control unit (ECU) provides processing for sensor data and responds with appropriate motor, brake, and signal commands. The initially installed software will be that described in Reference 6, with minor modifications. Subsequent changes to incorporate additional fail-safe algorithms or to improve performance will evolve subsequently. Initial design speed in the automated mode will be 7 mph. The ECU provides a junction point for signals from all sensing and control components and provides low-voltage power for those components that require it. It is made up from digital processing cards which

are commercial STD bus hardware, together with cards of special design which also fit the STD bus card cage. The ECU is housed in two STD bus card cages with a total capacity of 24 circuit cards, which provides an ample allowance for growth. Regulated power is supplied to all circuits via the card cage power bus. The following circuit cards make up the ECU.

3.1.1.1 Digital Processing Cards

- (1) Microprocessor card incorporating a Z-80 processor and a 2.5 MHz clock with RAM and EPROM.
- (2) Counter-timer card, which provides a timing reference for the ECU program cycle.
- (3) Analog I-O cards with 16 channels A/D and 2 channels D/A on each card. These cards provide I-O for analog signals, including motor control, tachometers, steering angle, etc.
- (4) TTL I-O cards, which provide I-O for on-off signals, including headway sensors, switch inputs, forward-reverse signal, steering acquisition, etc.
- (5) Relay card, which provides control signals for actuating large relays.

3.1.1.2 Analog Sensor and Interface Cards of Special Design

- (1) Road Marker card: contains a circuit for the road marker magnet detector, and interfaces with the external pickup coil. Sets a TTL high output on

passing over a signaling magnet in the road surface, and passes the signal to the microprocessor through the TTL I/O. The microprocessor resets the output to the low state immediately after reading it.

- (2) Steering sensor card: contains the active circuits for the steering sensor. Accepts signals from coils mounted under the vehicle to detect the guidewire signal, from which it generates an analog steering command signal. The output is passed to the steering servo input and to the microprocessor analog I/O for monitoring. It also generates a complementary pair of TTL steering acquisition signals. Complementary TTL signals, one low and one high indicate presence of guide-wire excitation. A software test based on the complementary pair will be performed by the microprocessor to detect loss of power or loss of continuity of the sensor output signal.
- (3) Signal Conditioning Card: contains a "keep-alive" monitor circuit for the microprocessor; passes through ± 12 V regulated power for optical sensors, and provides ± 5 V regulated excitation for analog potentiometers.

3.1.2 External Interfaces

Characteristics of the various input and output lines are shown in Tables 3-1, 3-2, and 3-3, categorized as signal input, signal output, or power.

Refer to Figures 3-3A, 3-3B, and 3-3C for a complete listing of external interfaces. On the diagrams, signals having an external interface will pass through connectors and one or more cable harnesses to other systems; those shown with internal connection are routed to other cards within the ECU.

3.2 HEADWAY SENSOR SYSTEM (B)

3.2.1 Functional Description

The headway sensor system shall provide a redundant TTL signal to slow the vehicle if an obstacle is detected in its path within a designated primary distance range. The system also generates a second and independent redundant TTL signal to stop the vehicle if an object is detected closer to the vehicle within the secondary sensor range. Auxiliary source and detector elements provide a similar function in the primary sensor distance range, but in the direction of a turn for either a left or a right turn, if enabled by a TTL signal from the ECU. The headway sensor hardware will consist of two sets of four optoelectronic units, each mounted in a vertical column near the side of the vehicle, a total of eight modules. The location of the two

TABLE 3-1. SIGNALS INPUT TO THE ECU FROM VARIOUS SENSORS

Key	Signal Source or Name	To Card Type	ECU Interpretation or Command
1	Primary headway sensor	TTL I/O	TTL low indicates an obstruction: commands slow vehicle speed
2	Secondary headway sensor	TTL I/O	TTL low indicates an obstruction: commands stop
3	Right-turn sensor	TTL I/O	TTL low indicates an obstruction: commands slow speed
4	Left-turn sensor	TTL I/O	TTL low indicates an obstruction: commands slow speed
5	U-turn sensor	TTL I/O	Complementary TTL pair indicates presence of an obstacle along side of AMTV on inside of turn: commands stop
6	Reset - initiate	TTL I/O	Initiates control program cycle: starts automated operation
7	Hydraulic-pressure low-limit switch in brake/steering system	TTL I/O	Contact opening indicates low pressure: commands vehicle stop
8	Door open switches	TTL I/O	Six switches wired in series. Any switch open commands vehicle stop
9	Door ajar switches	TTL I/O	Six switches wired in series. Contacts will open if door not latched. Any switch open commands vehicle stop. Restart occurs after automated verbal message to passengers and delay

TABLE 3-1. (CONT'D)

Key	Signal Source or Name	To Card Type	ECU Interpretation or Command
10	Passenger stop	TTL I/O	Six switches wired in series. Any switch opened momentarily commands vehicle stop. After delay, vehicle resumes travel in automated mode
11	Emergency stop push-button switch	TTL I/O	Three switches wired in series. Any switch opened momentarily commands vehicle emergency stop. Can only be restarted by authorized person
12	Peripheral contact switch	TTL I/O	Normally open (manufacturing restriction) switch. Momentary closure commands emergency stop. Vehicle can then only be restarted by authorized person
13	Windshield impact switches	TTL I/O	Normally open (restriction caused by component design) switch. Closure commands emergency stop. Vehicle can only be restarted by authorized person
14	Contact bumper switch	TTL I/O	Normally closed switch. Momentary opening commands emergency stop. Vehicle can only be restarted by authorized person
15	Steering-angle potentiometer	Steering servo and A/D #1	1) For feedback to steering servo card 2) To detect a steering anomaly for safety monitoring

TABLE 3-1. (CONT'D)

Key	Signal Source or Name	To Card Type	ECU Interpretation or Command
16	Analog Tach. #1	A/D #1	Vehicle speed sensing. -5 to +5V A/D range, with tach gain selected at 0.5 V/mph, so that saturation occurs at no less than 1.2 times auto-mode cruise speed
17	Analog Tach. #2	A/D #2	Vehicle speed sensing. Redundant input
18	Motor current shunt	A/D #2	Used to detect a runaway condition
19	Road marker sensor coil #1	Road marker sensor card #1	Reads road marker detector coil. Used to supply controller with route information
20	Road marker sensor coil #2	Road marker sensor card #2	Reads road marker detector coil. Used to supply controller with route information
21	Steering sensor coils	Steering sensor card #1	Each sensor assembly generates an analog audio frequency signal used for determining the location of the vehicle with respect to guide wire
22	Steering reference coils	Steering sensor card #1	Each reference coil generates an analog audio frequency signal used for providing a phase reference for the steering sensor circuit and for generating the acquisition signal

TABLE 3-2. SIGNALS OUTPUT FROM THE ECU TO SENSORS OR ACTUATORS

Key	From ECU Card	To Sensor/Actuator Output Name	Interpretation by Sensor or Actuator
30,31	TTL I/O	Turn sensor enable. Two outputs: right and left	TTL low turns on sensor
32	TTL I/O	Hydraulic brake apply valve	TTL high applies brake pressure
33	TTL I/O	Hydraulic brake release valve	TTL high releases brake pressure
34	TTL I/O	Motor controller power enable contactor	TTL high closes main contactor which energizes motor controller
35	TTL I/O	Spring applied brake release	TTL high applies hydraulic pressure to brake release cylinder
36	TTL I/O	Motor controller forward-reverse	TTL low sets motor controller forward-reverse solid-state switch to forward. TTL high selects reverse
38	D/A	Motor current control	0-5 V analog output controls motor current
39	D/A	Monitor (two signals)	A software patch can route any program variable to monitor jacks for diagnostics
40,41	Relay card	Turn signal relays. Two signals right, left	Relay closure turns right or left turn signal lights on

TABLE 3-2. (CONT'D)

Key	From ECU Card	To Sensor/Actuator Output Name	Interpretation by Sensor or Actuator
42	Relay card	Brake-light relay	Relay closure turns on brake lights
43	Relay card	Horn-power relay	Relay closure sounds horn
44	Relay output	U-turn sensor enable. Two outputs: right and left	TTL low turns on sensor
45	Signal conditioner	Interface unit relay actuation	An output goes from TTL I/O to keep-alive circuit in signal conditioner card. Hard wired logic there generates an enable signal which goes directly to normally open relays in the interface unit ^a

3-12

^aSee Paragraph (I). Actuation of relays enables both the release of the spring brake and the closure of the main motor power contacts in the motor controller.

TABLE 3-3. POWER SUPPLY OR EXCITATION VOLTAGES INPUT TO ECU

Key	Power Source	Voltage and Current	Power
50	Voltage converter	+12 Vdc	Power for special-purpose circuits
51	Voltage converter	-12 Vdc	Power for special-purpose circuits
52	Voltage converter	+5 Vdc	STD BUS Power

TABLE 3-4. POWER OR EXCITATION VOLTAGE PROVIDED BY ECU TO SENSORS OR SWITCHES

Key	From ECU Card	Voltage	Supplied to
61	Signal conditioner	<u>+12</u> Vdc	Headway sensor supply power
62,63	Signal conditioner	<u>+5</u> Vdc	Excitation voltage for steering-angle readout and manual control

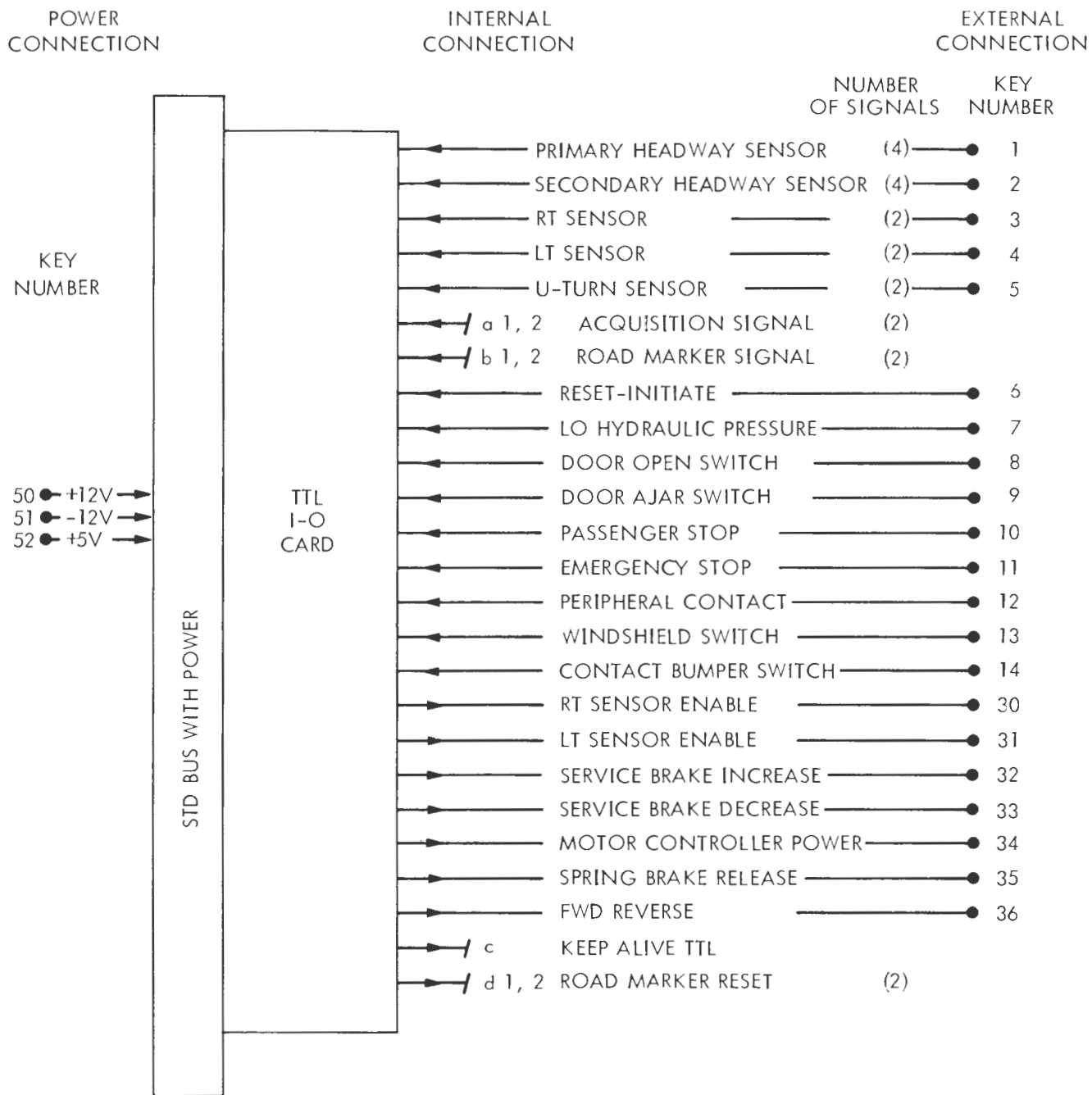

FIGURE 3-3A. ELECTRONIC CONTROL UNIT INTERFACES

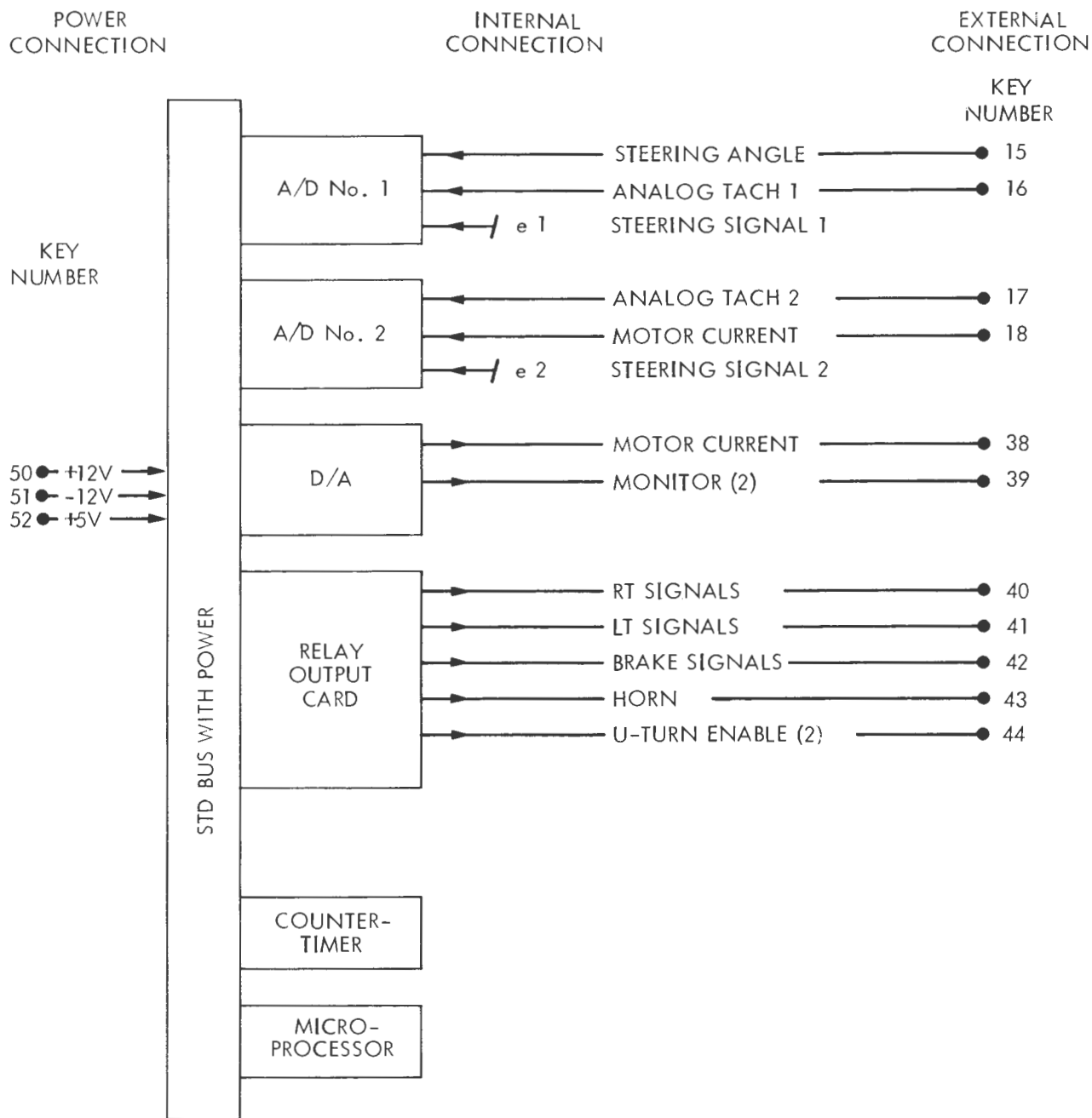

FIGURE 3-3B. ELECTRONIC CONTROL UNIT INTERFACES

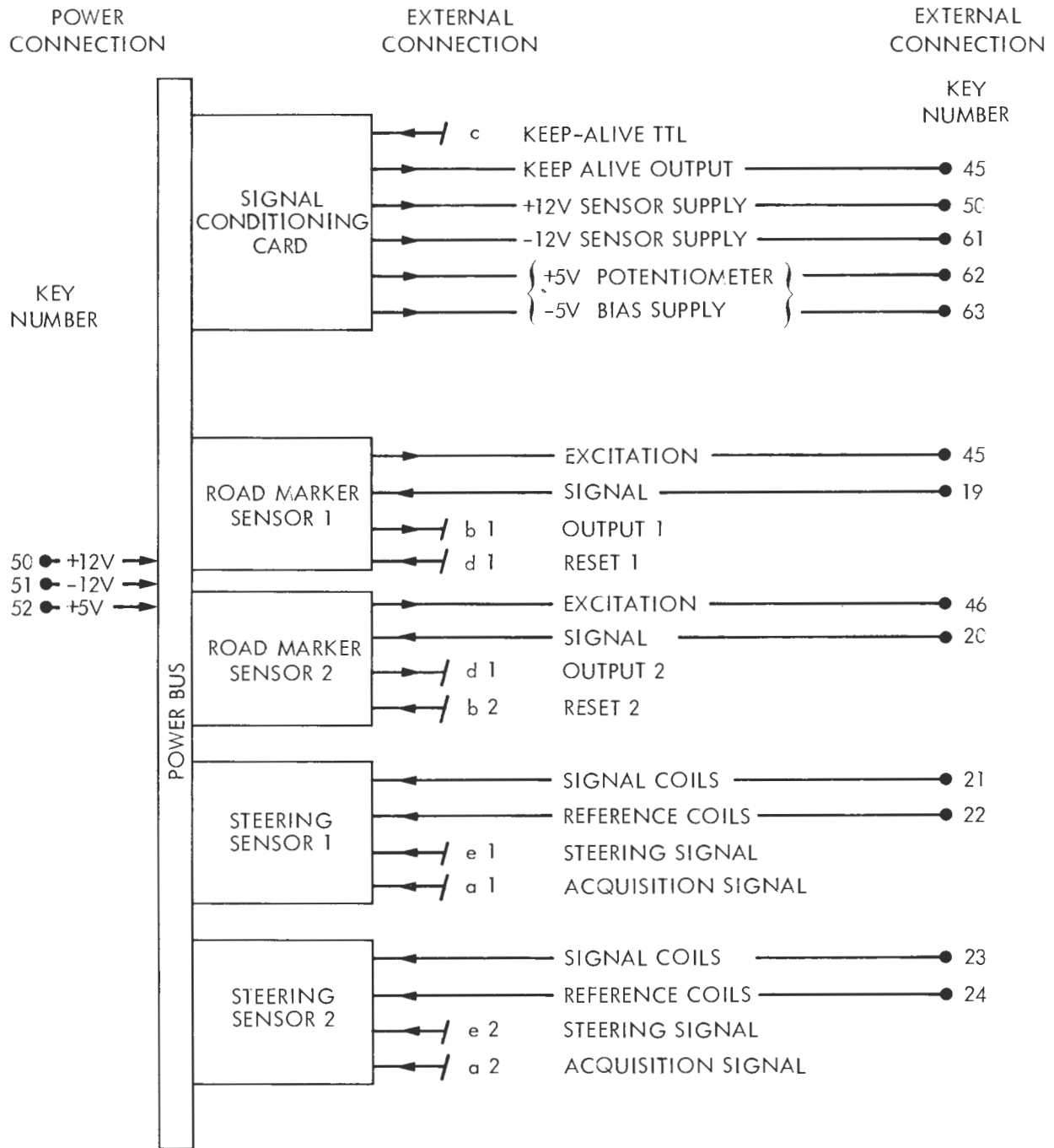

FIGURE 3-3C. ELECTRONIC CONTROL UNIT INTERFACES

sensor columns in the vehicle can be seen in Figure 3-1. In each column, two of the four units are LED source units and two are detector units. Logic must be provided in the ECU such that the power-off state of the turn sensor elements, which occurs on straight route sections, does not indicate an obstacle. The four elements in a column are mounted mechanically on a frame and together become an assembly that may be removed from the vehicle as a unit for testing or adjustment. The assembly is mounted with frangible bolts such that it can be displaced toward the rear with a reasonable force in order to minimize the chance of injury to pedestrians from the lens hoods or associated sensor parts mounted flush with the compliant front surface of the vehicle.

A near infrared (IR) optical proximity sensing concept is used. An LED source unit illuminates the field of view, and a corresponding detector unit receives light returned by diffuse reflection from an obstacle, if present. The source and detector units, similar to a camera, contain an array of LED or detector elements, respectively, in the focal plane of a lens. Each optoelectronic element is positioned in the focal plane to cover the desired field of view. Additional information on the function of the sensing system, on its design approach, and on techniques for obtaining fail-safe performance is contained in earlier reports and will not be repeated here. For further detail, the reader should refer to: (1) AMTV Technology and Safety Study, Reference 4, and (2) AMTV Headway Sensor and Safety Design, Reference 5.

sign, Reference 5.

3.2.2 Interfaces

3.2.2.1 Headway Sensor LED Source Unit

Power

+12 V $\pm 10\%$ 2.0 A Estimated unregulated 12 V power, total for all units.

Inputs

LT enable: Powers up appropriate components; TTL-level signal.

RT enable: Powers up appropriate components; TTL-level signal.

Synchronizing square wave signal - see item 3 following.

Outputs

A reference square wave from a master LED pulsing circuit is output to each detector unit for use as a phase reference, and to other source units for synchronization. TTL-level signal.

Mechanical

Each assembly consisting of a column of two source and two detector units is aligned by a common mounting frame. The relative alignment of the four optical units shall be stable to within ± 3 mrad. The complete assembly shall be mounted so that it is held in align-

ment with respect to the vehicle chassis within +1 deg. The assembly shall be mounted so that it can be displaced backwards if subjected to a force greater than 100 lb. Clearance for a displacement of at least 4 in. toward the rear shall be provided.

3.2.2.2 Headway Sensor Detector Unit

Power

+12 V 200 mA, total all units, regulated power.

+5 V 10 mA, total all units.

Inputs

- (1) Reference square wave from master source unit:
TTL-level signal.
- (2) LT enable or RT enable: powers up appropriate turn sensor detector elements.

Outputs

- (1) Primary sensor: all outputs are TTL-level signals which indicate the presence of an obstacle in the field of view of the given sensor elements. Multiple outputs are separately fed to the ECU to provide a multiply-redundant sensor function.
- (2) Secondary sensor similar to primary output, see (1) above.
- (3) LT sensor similar to primary output, see (1) above.
- (4) RT sensor similar to primary output, see (1) above.

Mechanical

Combined in assembly with source element; discussed above.

3.2.3 Specifications and Parameter Values

See References 4 and 5 for detail. The basic primary and secondary sensor fields of view are shown in Figure 3-4. Each sensor channel shall detect a black (3M Nextel Velvet 101-C10 black paint or equivalent) 8 in. wide target anywhere in the areas enclosed by the solid line on Figure 3-4. A retroreflective target shall be detected within but not outside the area enclosed by the dotted line.

The turn-sensing elements shall perform in a similar way over an area to the side, as discussed in Reference 5, Figure 3-2.

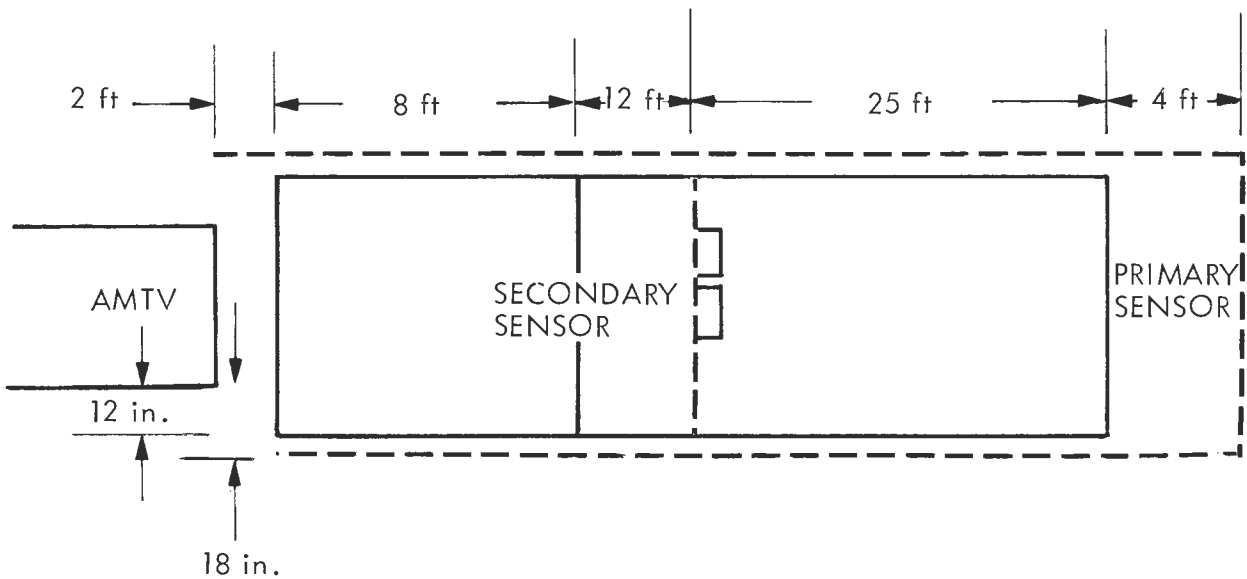

FIGURE 3-4. THE DETECTION AREAS OF THE HEADWAY SENSING SYSTEM FOR A BLACK TARGET AND FOR A RETROREFLECTIVE TARGET

3.3 MANUAL CONTROLLER ©

3.3.1 Functional Description

The manual controller shall provide a means to move AMTV II under its own power. It is required for positioning AMTV II in the laboratory and for moving it from the maintenance area to the route loop. Manual control of motor current, motor direction, steering, and brakes is required.

The controller shall consist of a plug-in box containing the necessary control devices (for example, a hand-held control for R/C model cars, or an equivalent arrangement). When the control box is plugged in, the vehicle control shall switch from the ECU to the manual input. Inputs shall be through a two-axis joystick, or similar means. A separate button shall release the holding brake, as long as the button is depressed.

3.3.2 Interfaces

Power

+5 V	Regulated Bias voltage for analog potentiometers
+ 5 V	Conditioned voltage for the switched inputs, enable, and forward-reverse.

Inputs

None

Outputs

See Interface Unit, Section 3.4.1, item (9).

3.4 INDICATOR PANEL (D)

3.4.1 Functional Description

The indicator panel shall provide an indication of the vehicle system state for an on-board observer; it provides an indication of the cause of an automatic (non-programmed) stop, through a set of indicator lights. The panel contains the auto-mode (initiate) button, which starts the automatic operating cycle, and a place to plug in the manual controller. The panel also contains the following items:

- (1) Speedometer.
- (2) Key-operated system off-on switch.
- (3) Steering offset indicator.
- (4) Sensor input indicator lights.
- (5) ECU status lights.
- (6) Auto-mode button.
- (7) Stop switch.
- (8) Light switches.
- (9) Battery voltage indicator.
- (10) Stop button: stops vehicle and interrupts automatic programmed cycle so vehicle remains stopped.
- (11) Plug-in jacks for ECU monitor function.
- (12) Hydraulic pressure gauge: physically mounted on the left side of the base of the middle seat near the hydraulic accumulator reservoir.

3.5 SWITCH INPUTS (E)

3.5.1 Functional Description

A set of switch inputs to the ECU shall provide a means for stopping the AMTV in response to several types of event or commands as follows:

3.5.1.1. Contact Switches. A tape switch is placed around the vehicle body on bumpers and side molding to detect contact. Actuation produces an emergency stop. Switch contacts are normally open, and close upon pressure; this is an inherent property of this type of switch.

3.5.1.2 Contact Bumper-Switch. A lightweight compliant bumper shall be provided at the front of the vehicle, which incorporates a switch arrangement to detect contact. These switch contacts shall be normally closed. The bumper-switch shall allow at least 2 ft of forward motion of the AMTV after actuation without damage to the bumper or injury to a pedestrian contacted by it. Actuation commands an emergency stop. This component is discussed further in Section 4.

3.5.1.3 Door-Open Switches. A switch mounted in the door frame on the hinged side provides an interlock so AMTV will not move with a door open. Actuation commands a normal stop. Opening a door past the ajar position opens the switch contacts. Switches for all doors are connected in series.

3.5.1.4 Door Ajar Switches. A magnetic reed switch mounted on the latch side of the door frame indicates when a door is unlatched. Each switch is closed when its door is closed and latched, but opens if it is unlatched. A door that is closed by its return spring against the latch, but is not latched, shall result in normal stop command, followed by a pause (approximately 30 s but actual duration is to be determined). When this occurs, following the pause a message is presented to the passengers to latch the door, after which the AMTV will move off at a safe (possibly reduced) speed. The purpose of these switches is to prevent the AMTV from being stopped indefinitely by a closed but unlatched door when no passengers are on board.

3.5.1.5 Passenger Stop Buttons. Button-actuated stop switches are provided inside the vehicle within reach of any passenger. Momentarily pressing the button commands a normal stop, followed by a pause (~ 3 s). If no additional stop input (e.g., an open door) occurs, the vehicle will move on after the pause.

3.5.1.6 Emergency-Stop Buttons. Distinctive button switches labeled "Emergency" shall command an emergency stop. This stop mode is not intended for use under normal conditions, and requires an authorized person to reset the system.

3.5.2 Interfaces

Power

A specially conditioned +5 V line is provided to all switches.

Outputs

Each switch output is conditioned appropriately to be read out by an ECU TTL card input channel.

3.6 ROAD MARKER SENSOR (F)

3.6.1 Functional Description

The purpose of the road marker sensor is to transmit one of a number of fixed messages to the vehicle ECU at predetermined points along the route. Examples of the messages are: stop, right turn, slow, etc. Two independent detectors, one on each side of the vehicle center line, are provided to allow redundancy and error detection. Each detector generates a TTL level output to the microprocessor TTL I/O when its sensing head passes over a signal magnet fixed in the road. Multiple messages are made available by reading several magnets against distance traveled using the two independent detectors. The messages are to be encoded in terms of magnet position and these codes shall be devised such that error detection algorithms can be included in the ECU. Each detector consists of two elements: (1) a sensing head mounted under the vehicle, and (2) a circuit card, which is physically located in the ECU card cage.

3.6.2 Interfaces

Sensing Head to Circuit Card

Defined by the existing sensor design used in AMTV I.
The interconnection between the two shall be made with shielded pair or coax.

Power

± 12 V and +5 V, provided from the ECU bus to the circuit card.

Input

Reset signal obtained from TTL IO.

Output

TTL signal indicating presence of magnet.

3.6.3 Specifications and Parameters

- (1) Output shall go high while pickup is over a magnet and will remain high until reset by signal from ECU.
- (2) The sensor shall be capable of detecting a signal magnet reliably at 30 mph.
- (3) Pickup coil is mounted under vehicle near front axle:
Height above road surface 3.5 ± 1 in.
Distance from vehicle center 11.5 ± 1 in.
- (4) One of the two pickups shall detect the magnets on the existing JPL-loop route.

3.7 STEERING SENSOR (G)

3.7.1 Functional Description

The steering sensor shall provide an analog signal for steering control, which is proportional to the lateral displacement of the vehicle, from a guidewire buried in the road surface. The steering sensor, together with a steering servo provides closed-loop control such that the AMTV accurately follows the guidewire. The sensor consists of two parts: (1) a pickup coil assembly mounted under the vehicle which contains passive detector coils, and (2) a circuit card, containing the active electronics. The pickup coil assembly contains two or more coils which, in combination, sense lateral displacements. A separate coil provides a reference signal from which a detection circuit derives a TTL acquisition signal to confirm the presence of the guidewire excitation. The reference signal is also used for phase detection in the analog circuitry which generates the steering signal. The steering sensor circuit card is located physically in the ECU.

3.7.2 Interfaces

Pickup Coil Assembly to Circuit Card

Two separate coil combinations require connection to the circuit card. Interconnection shall be by twisted shielded pairs. The coil impedance is approximately 1500 ohms at 10 kHz.

Power

+12 V, +5 V provided from ECU card cage power bus.

Outputs

Steering signal: -5-0+5 V analog signal to steering servo.

Output impedance: 100 ohm

Acquisition signal: a complementary pair of TTL-level signals to microprocessor TTL I/O.

Mechanical Interfaces

Pickup assembly shall be centered near the front axle, mounted 6 in. ± 1 " above nominal road surface.

3.7.3 Specifications and Parameter Values

Steering signal

- (1) Transfer function gain at center of range shall be 0.7 V/in. $\pm 20\%$.
- (2) The output signal shall remain a proportional indication of lateral displacement over a range of at least ± 5 V.
- (3) The sensor shall provide a usable (though non-linear) output signal over at least ± 16 in. displacement.
- (4) An adjustment shall be provided to bring zero output to within ± 1 in. of vehicle centerline.

Acquisition Signal

The acquisition circuit shall indicate acquisition if:

- (1) The vehicle lateral displacement is within ± 12 in. at nominal guidewire excitation amplitude.

- (2) The guidewire excitation amplitude is within $\pm 20\%$ of nominal, with the vehicle centered over the wire.

If these two conditions are not both satisfied, the sensor shall indicate a loss of acquisition. As steering control is a critical function with little opportunity for checks independent of the sensor, it is a requirement that its design provide stable control for all combinations of vehicle deflection, off nominal excitation, and other parameter variations possible within the range of acquisition. The acquisition signal is transmitted as a complementary pair. Redundant steering sensors with an ECU cross check are a desirable future development.

3.8 HYDRAULIC SYSTEM (H)

3.8.1 Functional Description

The hydraulic system provides steering actuation, a means of proportional application of the hydraulic service brakes, and releases the spring brake. The seals and fluid used in the hydraulic system and in the tram service brakes are compatible.

The system consists of the following parts:

- (1) Hydraulic pump, reservoir, and accumulator unit.

This unit provides a source of hydraulic pressure

for the actuators.

- (2) Steering actuator. Consists of a servo valve and accompanying servo circuit card (Moog 121-102), an actuation cylinder connected to the steering linkage, and linear potentiometer to provide a measure of the steering angle.
- (3) Service brake solenoid valves. The concept to be used for proportional control of the hydraulic service brakes is shown in Figure 3-5. The brake application pressure is incremented up or down as required by a command to one or the other of the two metering valves. The command is a fixed short (several milliseconds) opening pulse from the ECU to the appropriate valve, delivered in synchronism with the cycle time of the microprocessor speed control algorithm. An emergency stop command shall open and hold open the valve which increases brake pressure.
- (4) Spring brake release actuator. Consists of a solenoid valve and a cylinder to compress the spring, thus releasing the brake. The parking-brake band operating on the differential shaft is used.

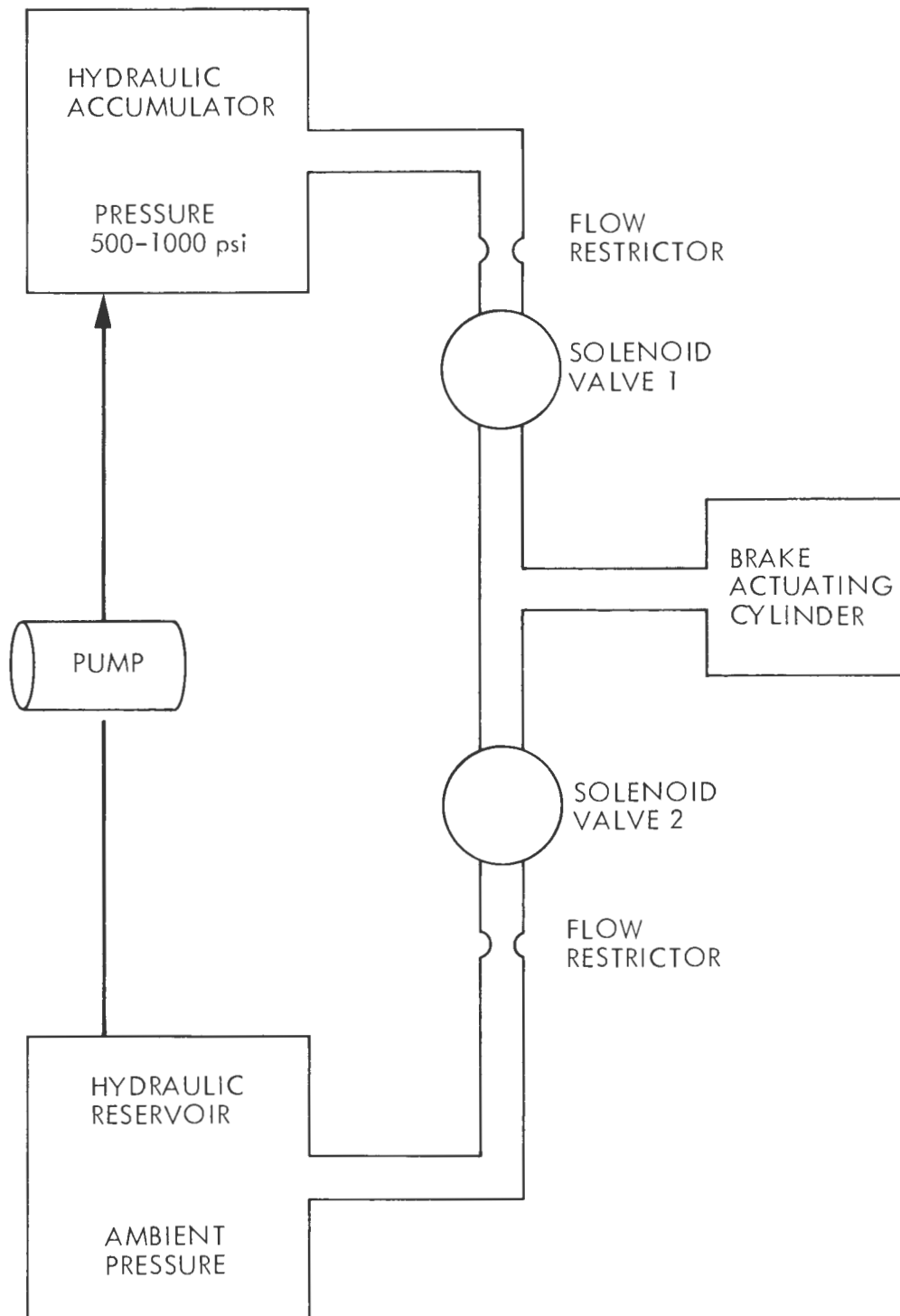

FIGURE 3-5. THE CONCEPT USED FOR PROPORTIONAL ACTUATION OF THE HYDRAULIC SERVICE BRAKES

3.8.2 Interfaces

Power

36 V, 19 A to pump motor; duty cycle approximately 5% after initial cycle.

Outputs

- (1) Linear potentiometer signal indicates steering angle; see ECU for definition.
- (2) Low-hydraulic-pressure switch output contacts close at 475 psi, open at 450 psi; open contact commands normal stop.

3.8.3 Specifications

The hydraulic supply unit and steering actuator essentially duplicate the unit on the present AMTV. The proportional service brake actuation is a new design, as is the spring brake release actuator.

3.9 INTERFACE UNIT (I)

3.9.1 Functional Description

The interface unit provides a means for switching the vehicle from automatic to manual control, and it provides special circuits as required to interface low-level control signals from the ECU to hydraulic valves and high current electrical contactors. The interface unit contains the automatic-manual relays and the steering servo card. The manual control box connects to

the interface unit.

3.9.2 Interfaces

Power

+12 V for the steering servo card.

Inputs

Steering angle from 5 k potentiometer mounted on the actuating cylinder. The following are signals from the manual control:

- (1) Steering signal; an analog signal used for manual steering (-5 to +5V).
- (2) Motor current command signal; an analog signal used for manual speed control (0 to +5V).
- (3) Forward reverse TTL level.
- (4) Deadman button switch input.
- (5) Manual enable; a contact closure activated when the manual control is plugged in.

The following are signals from the ECU:

- (1) Steering sensor signal; an analog signal -5 to +5V.
- (2) Motor current signal; an analog signal 0 to +5 V.
- (3) Service brake signal; a TTL level.
- (4) Forward Reverse signal; a TTL level.
- (5) Spring brake release; a TTL level.
- (6) Motor control power enable; a TTL level.
- (7) Keep-alive output signal; a TTL level obtained from hard-wired logic in the keep-alive circuit

in the ECU. A high level is required to operate in the automatic mode. Loss of the keep-alive signal shall cause the motor controller power-enable contacts to open, and the spring-brake solenoid valve to remove hydraulic pressure from the brake release actuator.

Outputs

The following output signals operate hydraulic valves; their current and voltage characteristics match the corresponding valve:

- (1) Steering servo valve signal.
- (2) Service brake (increment up) solenoid valve.
- (3) Service brake (increment down) solenoid valve.
- (4) Spring brake release solenoid valve.

The following signals operate the traction motor controller (see following paragraph); their characteristics shall match the controller.

- (1) Motor current
- (2) Forward reverse; TTL level.
- (3) Power enable relay actuation.

The steering angle signal is passed through the interface unit to the ECU, and serves as the feedback signal provided to the steering servo card internal to the interface unit.

3.10.1 Functional Description

The motor controller provides proportional control of motor current in response to signal inputs generated by the speed control algorithm in the ECU. The controller is also capable of supplying a proportional plugging torque which may be used for speed control and for a backup stopping function. This unit is a commercial product (Reference 20). In the future, the controller unit will also provide series-parallel switching of the two battery strings and the motor series field connections as required for a 7-20 mph mode. The 7-20 mph mode will not be implemented until after test and evaluation of the 0-7 mph mode is complete. A master relay energizes the controller and traction motor; this contact is closed by an enable signal from the ECU.

Operation of vehicle in the manual mode will also be done through the motor controller.

3.10.2 Interfaces

Power

For electronic circuits within the controller, 24 V, 5 A.

Inputs

- (1) Proportional motor current control signal; 0-5 V from ECU D/A or from manual control.
- (2) Forward-reverse; TTL level.
- (3) Power enable relay contact closure from relay - output channel of ECU.

Outputs

Traction motor current and polarity (rotation direction).

3.10.3 Specifications and Parameter Values

- (1) Configuration: Transistor chopper armature current control SCR switch for forward-reverse selection. Plugging mode for braking is incorporated.
- (2) Battery Voltage: 72 V maximum.
- (3) Current: 550 A, current limiting is provided in design.
- (4) Power Relay: Contacts normally open.

3.11 SPRING BRAKE (K)

3.11.1 Functional Description

The spring brake shall provide a fail-safe parking brake independent of the hydraulic service braking system. It is spring-applied. It is released by applying hydraulic pressure to an actuator on command from the ECU.

3.11.2 Specifications

The spring brake shall be capable of holding the AMTV

on the steepest grade encountered in the area where it will be operated, and against maximum traction motor torque. The maximum gradient is 20% for the JPL site.

3.12 U-TURN SENSOR (L)

3.12.1 Functional Description

The purpose of the U-turn sensor is to detect pedestrians or obstacles close to the side of the AMTV on the inside of a U-turn or other turn made at slow speed with hard-over or near hard-over steering angle. Ultrasonic sensors based on the Polaroid Pronto auto-focus sensor will be used; one sensor will be mounted on each side at the rear of the AMTV. An ECU algorithm will activate the unit on the inside of turn during the turn, based on steering angle information.

3.12.2 Interfaces

Power

12 \pm 2 V, 300 mA, while operating. Power shall be switched on by ECU to activate sensor.

Outputs

Detection of an obstacle produces a stop command to be indicated by a TTL complementary signal pair.

Specifications

Reference 5 should be consulted for detail on the geometry of the detection region.

3.13 WIRE EXCITER (M)

3.13.1 Functional Description

The wire exciter provides audio frequency (~10 kHz) excitation current for the guide wire. It contains an audio power oscillator an excitation level monitor, and impedance-matching circuits to couple the oscillator to the guide-wire loop.

3.13.2 Interfaces

Power

110 V 60 Hz

Outputs

Sinusoidal current to guide-wire loop. A series capacitor is used as the matching element to tune out the loop inductance. The value of the capacitance used in the JPL loop exciter is 0.2 μ fd, but this value depends on the length and geometry of the loop.

3.13.3 Specifications and Parameter Values

- (1) Current: 500 ma pk-pk \pm 10% - A monitor shall shut down exciter if current supplied to loop is not within limits.
- (2) Frequency: 9.8 kHz \pm 0.1 kHz
- (3) Output Power: 5 W (max)

SECTION 4
FUTURE ADDITIONS

Three additions to the basic AMTV II system design described above have been studied during the course of this task and are felt to offer desirable enhancements to the capability and reliability of AMTV II. These additions are:

- (1) 20-mph capability.
- (2) Compliant bumper switch.
- (3) Fail-safe design additions.

In addition to these items, continuing development and simplification of the headway sensing system is, of course, of fundamental importance to the future success of the AMTT concept. Improvements in headway sensor technology do not necessarily impact the functional design of the AMTV, although the nature of the sensing system may have an influence on the details of the vehicle design. However, sensor technology is beyond the scope of this report and is not discussed further here.

4.1 20-MPH CAPABILITY

A semi-guideway mode of operation for an AMTT system, described in an earlier report (Reference 4), may be important for sites where longer distances are involved, greater than about 1 mi. This mode involves protection of portions of an at-grade pathway by fencing or other barriers, so that other AMTVs will be the only conflicting traffic normally encountered. A cruising

speed on the order of 20 mph appears to be a reasonable possibility within the protected, semi-guideway portions of the route.

Three design modifications, described in the following paragraphs, would be necessary to allow experiments for testing this concept to be performed with AMTV II.

4.1.1 0- to 7-mph Capability

The present vehicle is geared for 7 mph maximum speed. The problem of providing 0-20 mph proportional speed control without unduly compromising the low-speed efficiency of the vehicle was investigated by Borisoff (Reference 21). The recommended approach is diagrammed in Figure 4-1. The two batteries, the transistor chopper motor controller, and electronic reversing switch are a part of the basic 7-mph design. The standard motor would be replaced with a split-series field motor, and the gearing would be changed to accommodate the 20-mph top speed. A set of high current contactors (relays) would be added to the motor controller located under the package shelf at the rear of the vehicle.

For the 0-7-mph mode, the motor would be operated at nominally 36 V in the series (long) field connection, motor speed, and power being controlled by solid-state chopper control of the applied voltage. The top speed in this mode results from the application of the 36-V paralleled battery line voltage directly to the motor through a bypass contactor. For higher speeds, the motor field connections and the two battery strings

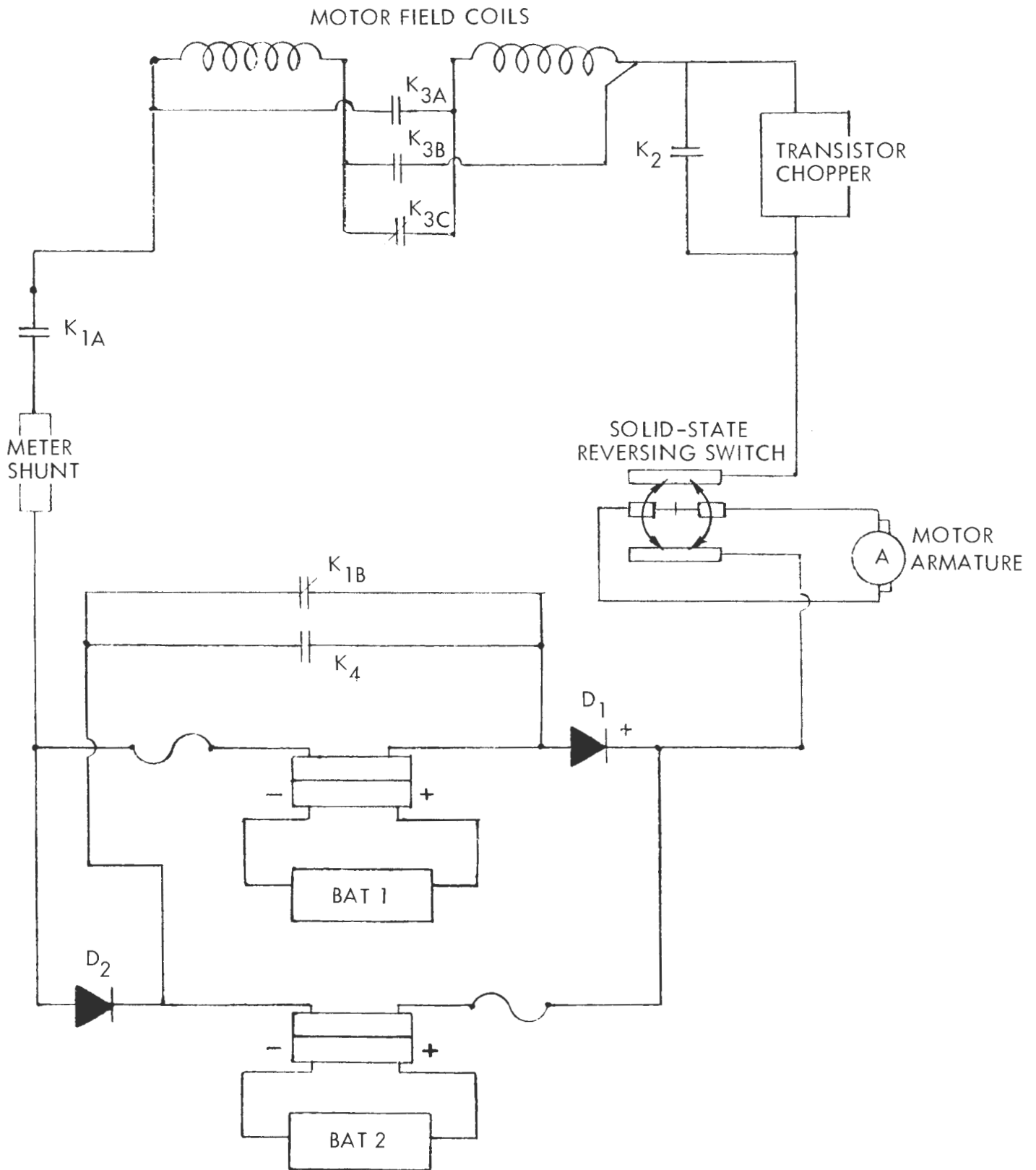

FIGURE 4-1. POWER SCHEMATIC FOR SWITCHING BETWEEN 0- TO 7-MPH MODE AND 7- TO 20-MPH MODE

would be sequentially switched, finally arriving at the parallel (short) field connection at 72 V, for an approximate 20-mph balancing speed.

By this method, the solid-state chopper operation is restricted to the 36-V paralleled battery connection and the lower-speed lower-current motor characteristic, which considerably simplifies the solid-state device application and avoids compromising the 0-7-mph operating efficiency. The higher speeds are obtained in three additional progressive steps whose motor speed/torque characteristics overlap sufficiently to keep torque transition steps to values which would not be objectionable to passengers.

Referring to Figure 4-1, in the power-off condition, the back (normally closed) contacts of the low-speed enabling contactor, K_1 , place the battery in the full series (72 V) connection, this being preferable to leaving the two battery halves connected in parallel when the vehicle is inactive.

Upon command from the guidance system, contactor K_1 actuates, dropping the battery to the 36-V paralleled mode and also completing the motor/chopper circuit, resulting in proportional motor control as the command voltage to the chopper is varied. The top speed in this 0-7-mph mode is attained by closure of chopper bypass contactor K_2 . At 4000 lb average tram service weight and 160 Wh/ton-mi specific power consumption, level running top speed motor circuit current draw would be about 70 A at 34.5 V average battery discharge voltage, that is, about

35 A per battery string.

For the high-speed mode, bypass contactor K_2 remains closed, removing the solid-state chopper from the higher speed mode currents and voltages. A coil switching algorithm would be used to sequentially operate contactors K_3 and K_4 as follows:

4.1.2 7- to 10-mph Capability

Contactors K_3 actuates to transfer the motor fields to the short field (higher speed) connection. Top or balancing speed motor current draw in this step would be about 90 A, that is about 45 A per battery unit.

4.1.3 10- to 15-mph Capability

Contactors K_3 is released to revert the motor to the long field (slower speed) connection and contactor K_4 is actuated to place the battery in the 72 V series configuration. At the balancing speed in this step, motor draw would be about 70 A, i.e., 70 A from each of the series-connected battery units.

4.1.4 15- to 20-mph Capability

Contactors K_4 remains actuated and contactors K_3 is re-actuated to place the motor in the short field connection. Balancing speed current draw would be about 100 A from the series-connected battery.

It should be noted that these are estimated current draws at the balancing speed for each condition, higher currents

being drawn during acceleration or hill climbing. Similarly, less battery current will be drawn running steady state below 7 mph, or going downhill.

The primary braking mode would be using the service brakes. The energy absorbing capacity of the motor precludes the use of plugging as the service braking mode in the higher speed regime (7-20 mph). The proportional hydraulic braking was described as part of the basic 7-mph system design. The primary fail-safe braking will be provided by the spring-applied parking brake, and a secondary backup can be obtained by plugging.

4.2 LONG-RANGE HEADWAY SENSORS

An added set of sensors would be required to detect other vehicles on the route at a distance of approximately 125 ft to permit a routine stop at the same levels of acceleration that are used at 7 mph and below. These sensors would be cooperative in nature, using the retroreflective lenses found in automotive tail lights. Dark diffusely reflective objects would be detected, as before, at 25 ft by the primary sensor channel, but in the protected route sections, such a detection would be an anomaly, commanding an emergency stop. Added sensor elements of the same type used in the primary sensor channel would be capable of providing the long range sensing capability just described.

4.3 STEERING SERVO UPGRADE

The dynamics of the steering control loop require

additional analysis and testing to ensure that adequate margins exist for reliable operation at 20 mph.

4.4 FAIL-SAFE DESIGN ADDITIONS

A number of design changes or additions have been identified as needed in earlier failure and hazard analyses, but have not yet been implemented in the basic system design. These concepts provide fail-safe responses in the event of assumed failures of any complete subsystem. AMTV II provides a framework to implement and test these concepts, which include:

4.4.1 Dual Microprocessors

Comparison of actual vehicle response to the predicted response of a model contained in a second processor is an approach which has been identified for fail-safe response to a number of failure types.

4.4.2 Dual Steering Sensors

4.4.3 Fail-Safe Road Marker Signals

4.4.4 Sudden Hard-Over Steering Failure Detection

4.5 COMPLIANT BUMPER-SWITCH

A concept for a compliant bumper-switch, shown in Figure 4-2, was developed as part of the AMTV II body design.

This concept involves a thin, lightweight "tongue" which is mounted so that it projects from the front of the vehicle close to the road surface. The structure is collapsible toward the rear and downward in two stages, first by a telescoping contact element and then by deflecting a pair of pivoted supporting arms on each side. The structure is intended to be strong enough to deflect downward without damage if stepped on. Development of a simpler, more durable concept is desirable.

The functional requirements are:

- (1) A relatively straight contact surface at least 2 ft in front of the front surface of the vehicle.
- (2) Switch indication of contact must occur with small deflection (~1 inch).
- (3) The bumper switch must collapse to or under the front of the vehicle without injury to a pedestrian contacted by it.
- (4) The configuration of the bumper switch must not allow a pedestrian to step behind it without detection.
- (5) Inadvertent contact or being stepped on shall not damage the bumper switch.

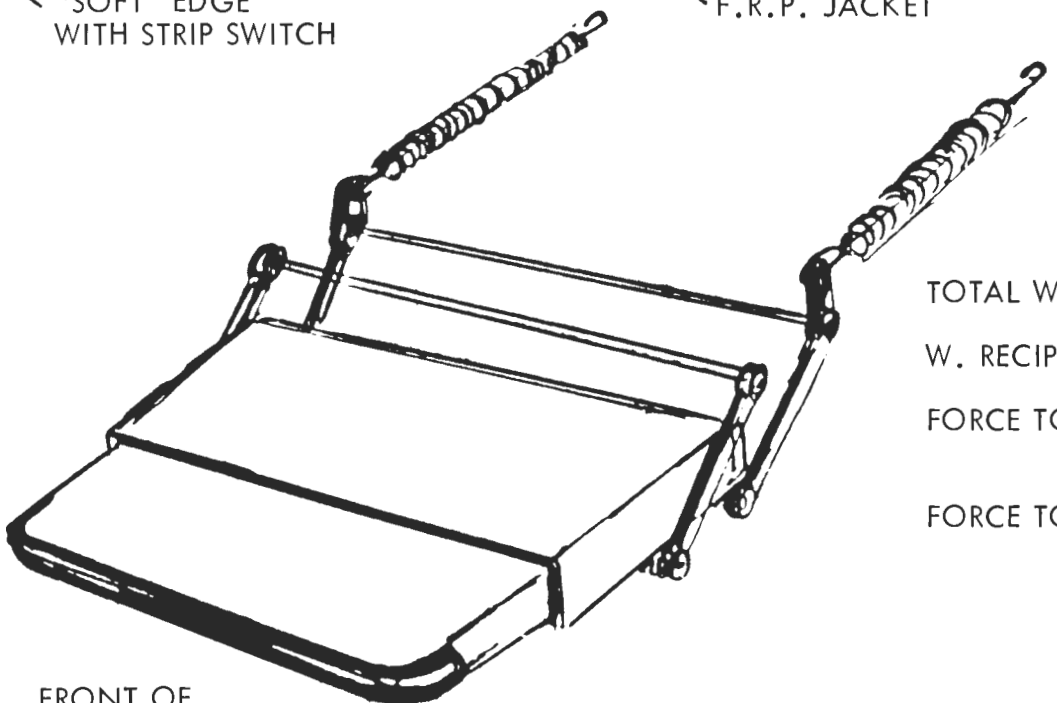
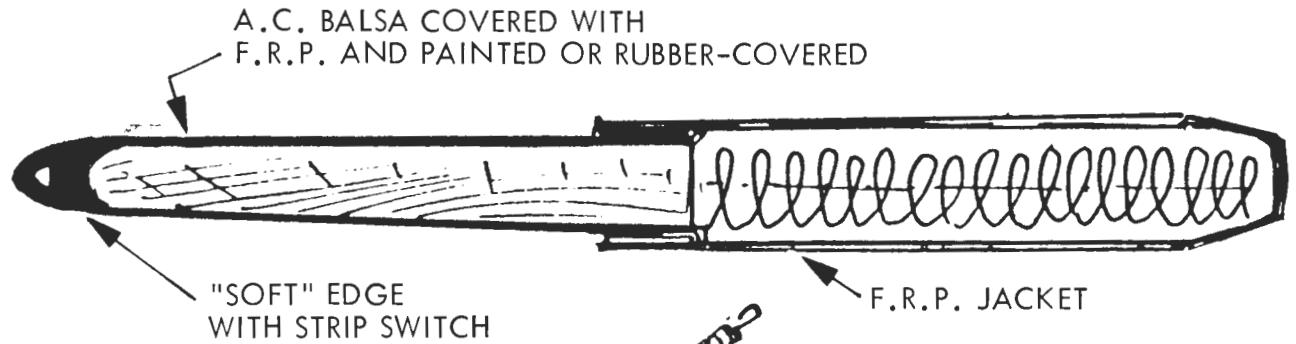

TOTAL WEIGHT: 15 LB
 W. RECIPROCATOR: 6 LB
 FORCE TO TELESCOPE: 15 LB MAX
 3 LB INITIAL
 FORCE TO ROTATE DOWNWARD: 35 LB MAX
 10 LB INITIAL

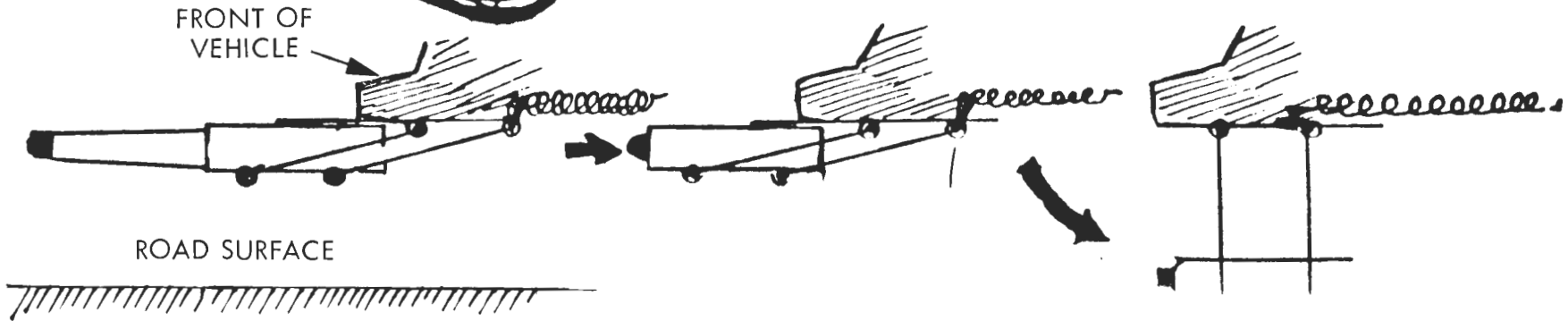

FIGURE 4-2. A PROPOSED DESIGN FOR A COMPLIANT CONTACT BUMPER SWITCH

6-7

SECTION 5

CONCLUSIONS

The foregoing sections have described the vehicle design, the sensor and control system design, and desirable modifications to extend the vehicle capability and reliability. The resulting vehicle with or without the modifications will be useful for applications experiments and for human factors testing.

It will be suitable for demonstration in a user environment under appropriate conditions. While still in a developmental phase, it will be necessary to provide observers for safety backup, either as riders or as roadside observers with override stop capability using radio control. As field experience accumulates, the observers would be gradually phased out, after the design stabilizes and is subjected to detailed safety review. Because the guidewire placement is inexpensive, and can even be surface mounted for a short-term demonstration, user environment demonstrations of the same vehicle at a number of sites appear to be feasible.

In addition to demonstration use, AMTV II can be useful for experiments in a realistic environment to aid in the development of new sensing and control technology, and in the development and test of other components of an AMTT system. The vehicle itself will be an operating test bed, and the Fortran programmable controller lends itself easily to rapid implementa-

tion and test of changes in control algorithms or parameters.

Examples of components or concepts which could be investigated readily with the new vehicle are:

- (1) Smart headway sensors, using an imaging sensor and processor to map an area in front and to each side of the vehicle.
- (2) Annunciation; processor-controlled voice messages to assist riders and interacting pedestrians.
- (3) Two vehicle interactions, using both AMTV I and AMTV II on the same route. Of particular interest will be study of possible interactions between headway sensors of opposing vehicles on the same street.
- (4) Traffic signal coupling.
- (5) Scheduling control.
- (6) Discreet marker guidance; steering control using highway lane marking buttons.

SECTION 6

REFERENCES

1. Meisenholder, G.W., and Johnston, A.R., "Control Techniques for an Automated Mixed Traffic Vehicle," Proceedings, Joint Automatic Control Conference, p. 421, San Francisco, June 1977.
2. Meisenholder, G.W., and Johnston, A.R., "Automated Mixed Traffic Vehicle Status," Proceedings, Automated Guideway Transit Conference, UMTA, Cambridge, Massachusetts, February 1978.
3. Johnston, A.R., "Automated Mixed Traffic Transit Technology Development," Presentation at Fourth UMTA R&D Conference, Norfolk, Virginia, November 19, 1980.
4. Johnston, A.R., Peng, T.K.C., Vivian, H.C., and Wang, P.K. "AMTV Technology and Safety Study," UMTA-CA-06-0088-78-1, February 1978.
5. Johnston, A.R., Nelson, M., Cassell, P., Herridge, J.T., "AMTV Headway Sensor and Safety Design," Report No. UMTA-CA-06-0088-80-1, January 1980.
6. Marks, R.A., Cassell, P., Johnston, A.R., "Automated Mixed Traffic Transit Vehicle Microprocessor Controller," UMTA-CA-06-0088-81-1, February 1981.
7. Herridge, J.T., "Design of Pedestrian Protection in the JPL Automated Mixed Traffic Vehicle," Battelle Columbus Laboratories, September 14, 1979.
8. Peng, T.K.C. and Chon, K. "Automated Mixed Traffic Vehicle Control and Scheduling Study," UMTA RD-CA-06-0088-76-1, December 1976.
9. Chung, C., Anyos, T., Ellis, H., Henderson, C., Lizak, R. and Wilhelm, J., "Automated Mixed Traffic Transit (AMTT) Market Analysis," UMTA VA-06-0056-80-3, August 1980.
10. Chung, C., "Automated Mixed Traffic Vehicle Study at Washington National Airport," Report No. UMTA-VA-06-0056-79-1, November 1979.
11. Chambliss, A.G., "The Urban Application Potential of Near Term Automated Mixed Traffic Transit," Report No. UMTA-VA-06-0056-80-2, September 1980.

12. Strickland, L.R., "Automated Guideway Transit Technology Overview," Report No. UMTA-VA-06-0041-78-1, February 1978.
13. Daniel, G., Hoyler, R., Izumi, G., MacKinnon, D., Driver, A., Sussman, D., and Chambliss, A., "Advanced Transit Technology Development," Report No. UMTA-VA-86-0056-80-4.
14. Lenard, M., "Life Cycle Costs and Application Analyses for New Systems Proceedings," Conference on Automated Guideway Transit Technology Development, Cambridge, Massachusetts, p. 329, UMTA-MA-06-0048-78-1, February 28, 1978.
15. Lockerby, C.E., "Obstacle Detectors for Automated Transit Vehicles: A Technoeconomic and Market Analysis," Contract NAS2-10143 Final Report, SRI International, Project 8134.
16. Howe, J.W., Heft, R.C., "Automated Mixed Traffic Transit: Analysis of Service Characteristics and Demonstration Site Requirements," Jet Propulsion Laboratory, Unpublished Report, November 1980.
17. Jarmus, S.C., "Liability and Insurability Considerations for AMTT," Jet Propulsion Laboratory, Unpublished Report, January, 1981.
18. Workshop Notes, "First Automated Mixed Traffic Transit (AMTT)," Vehicle Workshop, Jet Propulsion Laboratory, Unpublished Report, January 27, 1981.
19. Obtained from Taylor Dunn, Inc., Anaheim, California.
20. Obtained from EVC, Inc., El Segundo, California.
21. Borisoff, R., "Design Study for Electric Tram Speed Increase," Private Communication, March 1980.