



U.S. Department
of Transportation

**Urban Mass
Transportation
Administration**

UMTA-MA-06-0049-81-14
DOT-TSC-UMTA-82-5

S.C.R.T.D. LIBRARY

Lift-Equipped Bus Service in Seattle, Washington

**Final Report
March 1982**

TV
5022
K63

**UMTA/TSC Project Evaluation Series
Service and Methods Demonstration Program**

03438

HV
3022
.K63

NOTICE

This document is disseminated under the sponsorship of the Department of Transportation in the interest of information exchange. The United States Government assumes no liability for its contents or use thereof.

NOTICE

The United States Government does not endorse products or manufacturers. Trade or manufacturers' names appear herein solely because they are considered essential to the object of this report.

Technical Report Documentation Page

| | | | | | |
|--|--|--|--|---|-----------|
| 1. Report No. UMTA-MA-06-0049-81-14 | | 2. Government Accession No. | | 3. Recipient's Catalog No. | |
| 4. Title and Subtitle LIFT-EQUIPPED BUS SERVICE IN SEATTLE, WASHINGTON | | | | 5. Report Date March 1982 | |
| | | | | 6. Performing Organization Code DTS-243 | |
| 7. Author(s) David Koffman | | | | 8. Performing Organization Report No. DOT-TSC-UMTA-82-5 | |
| 9. Performing Organization Name and Address Crain & Associates, Inc.* 120 Santa Margarita Avenue Menlo Park, CA 94025 | | | | 10. Work Unit No. (TRAILS) UM227 /R2676 | |
| | | | | 11. Contract or Grant No. DOT-TSC-1408 | |
| | | | | 13. Type of Report and Period Covered Final Report February 1980 - July 1981 | |
| 12. Sponsoring Agency Name and Address U.S. Department of Transportation Urban Mass Transportation Administration Office of Planning, Management and Demonstrations Office of Service and Methods Demonstrations Washington DC 20590 | | | | 14. Sponsoring Agency Code UPM-30 | |
| | | | | 15. Supplementary Notes *Under contract to: U.S. Department of Transportation Research and Special Programs Administration Transportation Systems Center Cambridge MA 02142 | |
| 16. Abstract The Municipality of Metropolitan Seattle (Metro) offers extensive lift-equipped, fixed-route bus service. This report contains the results of a case study of Metro's experience, focusing on the months of June through August 1980, but including some data from the period of February 1980 to July 1981. The service was initiated in August 1979. It has been relatively reliable and well-used compared to most planning, ridership, service reliability, lift operations, policies and procedures, mechanical reliability, and costs. Implications for future lift-equipped bus services are discussed. | | | | | |
| 17. Key Words Elderly and Handicapped Transportation, Accessible Bus Service, Wheelchair Lifts, Accessibility | | | 18. Distribution Statement DOCUMENT IS AVAILABLE THROUGH SUPERINTENDENT OF DOCUMENTS U.S. GOVERNMENT PRINTING OFFICE WASHINGTON DC 20402 | | |
| 19. Security Classif. (of this report) UNCLASSIFIED | | 20. Security Classif. (of this page) UNCLASSIFIED | | 21. No. of Pages 182 | 22. Price |

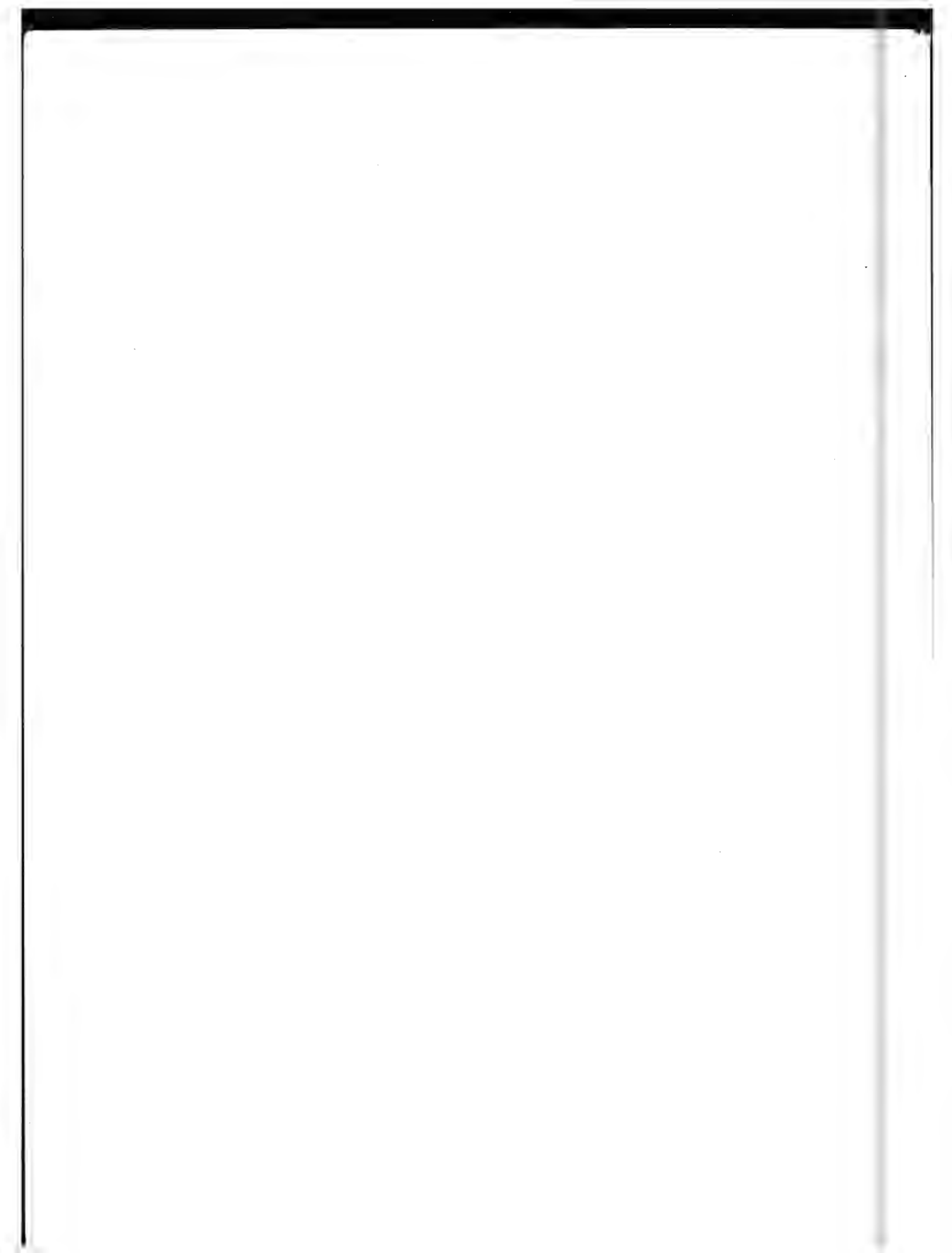

PREFACE

This case study report was prepared by Crain & Associates, Inc. at the request of the Transportation Systems Center (TSC) and the Urban Mass Transportation Administration (UMTA) under contract DOT-TSC-1408. Seattle Metro provided the data for the report and conducted surveys. The purpose of the study was to document the successful lift-equipped bus service in Seattle in order to determine the reasons for its success and the implications for future lift-equipped bus services.

The TSC project manager was Robert Casey. The project manager for UMTA was Lynn Sahaj. The principal investigator for Crain & Associates was David Koffman. He was assisted by Cindy Olander and Gerald Latter. John Crain reviewed the report, which was typed by MaryJeanne McAteer, Irene Sheiner and Ruth Campbell. Richard Blinkal provided support services.

The staff of Seattle Metro were extraordinarily helpful. The primary contact at Metro was Marilyn Watkins. Others at Metro who assisted the study include: B.J. Carol, Supervisor of Customer Assistance; Gretchen Roosevelt, Staff Assistant, Marketing Services; Jerry Dow, Manager, Transit Development; Pat Sullivan, Supervisor of Unit Repair; Emmett Heath, Management Analyst, Equipment and Facilities; Jim Burton, Manager of Equipment and Facilities; John Flug, Ridership Information; Paul Donnelly, Supervisor of Scheduling; Howie Picht, Manager of Service Control; Wayne Huston, Supervisor of Instruction; Lars Hjermstad, Consultant Coordinator, Bus Procurement; Gary Gallager, Manager of Computer Services; Mike Lewis, Supervisor of Risk Administration; Dave Buzzard, Supervisor, Arms Control & Accounts Payable; Jim Munson, Manager of Accounting; and Jane Dye, Transit Research Analyst.

METRIC CONVERSION FACTORS

Approximate Conversions to Metric Measures

| Symbol | When You Know | Multiply by | To Find | Symbol |
|----------------------------|---------------------------|----------------------------------|------------------------|-----------------|
| LENGTH | | | | |
| in | inches | 2.5 | centimeters | cm |
| ft | feet | 30 | centimeters | cm |
| yd | yards | 0.9 | meters | m |
| mi | miles | 1.6 | kilometers | km |
| AREA | | | | |
| in ² | square inches | 6.5 | square centimeters | cm ² |
| ft ² | square feet | 0.09 | square meters | m ² |
| yd ² | square yards | 0.8 | square meters | m ² |
| mi ² | square miles | 2.6 | square kilometers | km ² |
| | acres | 0.4 | hectares | ha |
| MASS (weight) | | | | |
| oz | ounces | 28 | grams | g |
| lb | pounds | 0.45 | kilograms | kg |
| | short tons (2000 lb) | 0.9 | tonnes | t |
| VOLUME | | | | |
| tsp | teaspoons | 5 | milliliters | ml |
| Tbsp | tablespoons | 15 | milliliters | ml |
| fl oz | fluid ounces | 30 | milliliters | ml |
| c | cups | 0.24 | liters | l |
| pt | pints | 0.47 | liters | l |
| qt | quarts | 0.96 | liters | l |
| gal | gallons | 3.8 | liters | l |
| ft ³ | cubic feet | 0.03 | cubic meters | m ³ |
| yd ³ | cubic yards | 0.76 | cubic meters | m ³ |
| TEMPERATURE (exact) | | | | |
| °F | Fahrenheit temperature | 5/9 (after subtracting 32) | Celsius temperature | °C |

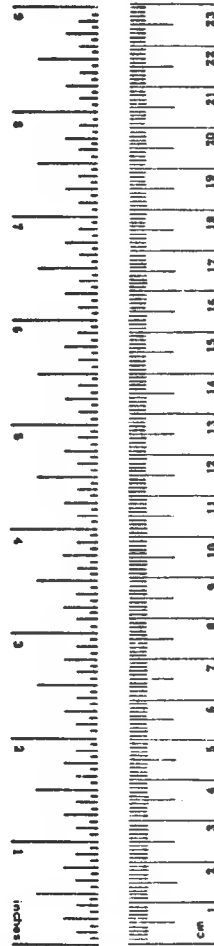

Approximate Conversions from Metric Measures

| Symbol | When You Know | Multiply by | To Find | Symbol |
|----------------------------|-----------------------------------|----------------------|---------------------------|-----------------|
| LENGTH | | | | |
| mm | millimeters | 0.04 | inches | in |
| cm | centimeters | 0.4 | inches | in |
| m | meters | 3.3 | feet | ft |
| m | meters | 1.1 | yards | yd |
| km | kilometers | 0.6 | miles | mi |
| AREA | | | | |
| cm ² | square centimeters | 0.16 | square inches | in ² |
| m ² | square meters | 1.2 | square yards | yd ² |
| km ² | square kilometers | 0.4 | square miles | mi ² |
| ha | hectares (10,000 m ²) | 2.5 | acres | |
| MASS (weight) | | | | |
| g | grams | 0.036 | ounces | oz |
| kg | kilograms | 2.2 | pounds | lb |
| t | tonnes (1000 kg) | 1.1 | short tons | |
| VOLUME | | | | |
| ml | milliliters | 0.03 | fluid ounces | fl oz |
| l | liters | 2.1 | pints | pt |
| l | liters | 1.06 | quarts | qt |
| l | liters | 0.26 | gallons | gal |
| m ³ | cubic meters | 35 | cubic feet | ft ³ |
| m ³ | cubic meters | 1.3 | cu. ft. yards | yd ³ |
| TEMPERATURE (exact) | | | | |
| °C | Celsius temperature | 9/5 (then add 32) | Fahrenheit temperature | °F |

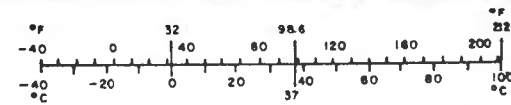

TABLE OF CONTENTS

| <u>Section</u> | <u>Page</u> |
|---|-------------|
| 1. INTRODUCTION | 1 |
| 1.1 Background | 1 |
| 1.2 Study Objectives | 1 |
| 1.3 Study Approach | 2 |
| 1.4 Time Period | 3 |
| 2. SETTING | 5 |
| 2.1 General Information | 5 |
| 2.2 Transit Service | 5 |
| 2.3 Elderly and Handicapped Transportation | 6 |
| 3. PROGRAM DESCRIPTION | 9 |
| 3.1 History | 9 |
| 3.1.1 Background | 9 |
| 3.1.2 Equipment Testing and Selection | 9 |
| 3.1.3 Service Planning | 10 |
| 3.1.4 The Driver Task Force | 11 |
| 3.1.5 Initiation of Service | 12 |
| 3.2 Extent of Service | 13 |
| 3.3 Plans for Future Service | 17 |
| 3.4 Vehicles | 17 |
| 3.4.1 General | 17 |
| 3.4.2 Wheelchair Stations and Securement | 18 |
| 3.5 The Lift | 18 |
| 3.5.1 General | 18 |
| 3.5.2 Boarding and Deboarding Operation | 23 |
| 3.5.3 Mechanical Principles | 26 |
| 3.5.4 Safety Features | 27 |
| 3.6 Policies and Procedures | 27 |
| 3.6.1 When and Where the Lift Will be Operated | 27 |
| 3.6.2 Boarding and Deboarding | 28 |
| 3.6.3 Driver Responsibilities | 30 |
| 3.7 Driver Training and Attitudes | 31 |
| 3.7.1 Training | 31 |
| 3.7.2 Attitudes | 32 |
| 3.8 Marketing and Outreach | 34 |
| 3.8.1 Public Information | 34 |
| 3.8.2 Outreach | 36 |

TABLE OF CONTENTS (Cont.)

| <u>Section</u> | <u>Page</u> |
|---|-------------|
| 4. RIDERSHIP | 39 |
| 4.1 Ridership Levels | 39 |
| 4.1.1 Boarding Counts | 39 |
| 4.1.2 Comparison with Other Systems | 40 |
| 4.1.3 Ridership by Route | 42 |
| 4.1.4 The Effect of Weather | 42 |
| 4.2 Ridership Characteristics | 44 |
| 4.2.1 Description of the Lift-User Survey | 44 |
| 4.2.2 Travel Characteristics | 45 |
| 4.2.3 Personal Characteristics | 45 |
| 4.3 Reasons For Use | 51 |
| 4.3.1 Switching From Other Modes | 51 |
| 4.3.2 New Trips | 51 |
| 4.3.3 Effectiveness of Marketing and Outreach | 51 |
| 4.4 Potential Users | 53 |
| 4.4.1 Description of the Potential User Survey | 53 |
| 4.4.2 Need for and Interest in Accessible Service | 53 |
| 4.4.3 Personal Characteristics | 54 |
| 4.4.4 Travel Characteristics | 54 |
| 4.4.5 Availability of Service | 57 |
| 4.4.6 Barriers to Use | 57 |
| 4.4.7 Conclusions from User/Potential User Comparison | 57 |
| 4.5 Explanation for Ridership Levels. | 58 |
| 4.5.1 Total vs. Proportional Lift Use | 58 |
| 4.5.2 Possible but Unlikely Reasons for High Ridership | 58 |
| 4.5.3 Likely Reasons for High Ridership | 60 |
| 4.5.4 High General Ridership and Extensive Lift Service | 60 |
| 4.5.5 Reliable Service | 60 |
| 4.5.6 Good Service Planning | 61 |
| 4.5.7 Good Marketing | 62 |
| 4.5.8 Favorable Attitude and Commitment | 63 |
| 4.5.9 Other Factors | 63 |
| 4.5.10 Opinions of Handicapped Spokespersons | 64 |
| 5. SERVICE QUALITY | 67 |
| 5.1 Reliability | 67 |
| 5.1.1 Passengers Passed Up | 67 |
| 5.1.2 Missed Assignments | 68 |
| 5.1.3 Passenger Experiences | 69 |
| 5.1.4 Complaints | 70 |

TABLE OF CONTENTS (Cont.)

| <u>Section</u> | <u>Page</u> |
|---|-------------|
| 5.2 Safety | 71 |
| 5.2.1 Waiting | 71 |
| 5.2.2 Riding the Lift | 71 |
| 5.2.3 Riding the Bus | 71 |
| 5.2.4 Accidents and Claims | 72 |
| 5.3 Ease of Use | 72 |
| 6. IMPACT ON METRO | 75 |
| 6.1 Equipment Reliability | 75 |
| 6.1.1 Frequency of Repair | 75 |
| 6.1.2 Discussion of Lift Problems | 76 |
| 6.2 Schedules | 76 |
| 6.3 Cost | 78 |
| 6.3.1 Capital Cost | 79 |
| 6.3.2 Start-up Costs | 79 |
| 6.3.3 Operating Costs | 80 |
| 6.3.4 Cost per Trip | 84 |
| 7. CONCLUSIONS | 87 |
| 7.1 Ridership | 87 |
| 7.2 Equipment Reliability | 87 |
| 7.3 Service Reliability | 88 |
| 7.4 Planning and Implementation | 88 |
| 7.5 Cost Effectiveness | 89 |
| 7.6 Implications for Other Transit Systems | 89 |
| 7.6.1 Ridership | 89 |
| 7.6.2 Mechanical Reliability | 89 |
| 7.6.3 Service Reliability | 90 |
| 7.6.4 Planning and Implementation | 90 |
| APPENDIX A ACCESSIBLE SERVICE TRAINING OUTLINE. | A-1 |
| APPENDIX B DRIVER SURVEY. | B-1 |
| APPENDIX C LIFT BULLETIN. | C-1 |
| APPENDIX D LIFT-USER SURVEY | D-1 |
| APPENDIX E POTENTIAL USER SURVEY. | E-1 |
| APPENDIX F CARD USED IN LIFT USE COUNTS | F-1 |
| APPENDIX G REPORT OF NEW TECHNOLOGY | G-1 |

TABLE OF CONTENTS (Cont.)

FIGURES

| <u>Figure</u> | | <u>Page</u> |
|---------------|--|-------------|
| 3-1 | ACCESSIBLE BUS COVERAGE | 14 |
| 3-2 | INTERIOR LAYOUT OF ACCESSIBLE BUS | 19 |
| 3-3 | WHEELCHAIR POSITIONS WITH SECUREMENT DEVICES | 20 |
| 3-4 | RIDING THE LIFT IN A WHEELCHAIR | 21 |
| 3-5 | RIDING THE LIFT IN A STANDING POSITION | 22 |
| 3-6 | DUCK TO ENTER | 22 |
| 3-7 | LIFT OPERATING CONCEPT AND CONTROLS | 24 |
| 3-8 | RUN CARD DECAL | 24 |
| 3-9 | LIFT OPERATION - BOARDING SEQUENCE | 25 |
| 3-10 | MECHANICAL PRINCIPALS OF LIFT-U LIFT | 26 |
| 3-11 | FLYER COACH WITH ACCESSIBILITY MARKINGS | 28 |
| 3-12 | METRO'S INSTRUCTIONS TO LIFT USERS | 29 |
| 3-13 | TIMETABLE FOR ACCESSIBLE SERVICE | 35 |
| 3-14 | LIST OF ACCESSIBLE STOPS | 37 |
| 4-1 | PLOT OF LIFT USE AND TOTAL REVENUE RIDERS | 43 |

TABLES

| <u>Table</u> | | |
|--------------|--|----|
| 2-1 | METRO SERVICE CHARACTERISTICS, 1974-79 | 7 |
| 3-1 | FREQUENCY OF ACCESSIBLE BUS COVERAGE | 15 |
| 3-2 | FRACTION OF SERVICE ACCESSIBLE BY ROUTE (APRIL 1980) | 16 |
| 3-3 | DRIVER OPINION OF LIFT OPERATION TRAINING | 32 |
| 3-4 | RESULTS OF DRIVER SURVEY | 33 |
| 3-5 | DRIVER COMMENTS | 34 |
| 4-1 | LIFT USE COUNTS | 39 |
| 4-2 | COMPARISON OF PROPORTIONAL LIFT USAGE | 41 |
| 4-3 | LIFT USE BY ROUTE | 43 |
| 4-4 | TOTAL BUS TRIPS BY PURPOSE | 46 |
| 4-5 | TRANSFERS BY PURPOSE | 46 |
| 4-6 | LIFT USER TRAVEL CHARACTERISTICS | 47 |
| 4-7 | TRAVEL CHARACTERISTICS BY FREQUENCY OF USE | 48 |
| 4-8 | USE AND AVAILABILITY OF OTHER MODES | 49 |
| 4-9 | LIFT USER PERSONAL CHARACTERISTICS | 50 |
| 4-10 | REASONS FOR SWITCHING TO BUS | 51 |
| 4-11 | WHAT CAN YOU NOW DO OR DO MORE OFTEN | 52 |
| 4-12 | HOW USERS LEARNED ABOUT ACCESSIBLE SERVICE | 52 |
| 4-13 | POTENTIAL USERS' ABILITY TO USE STAIRS | 53 |
| 4-14 | INTEREST IN USING LIFT BUSES | 54 |
| 4-15 | COMPARISON OF POTENTIAL USERS AND USERS | 55 |
| 4-16 | INCOME OF POTENTIAL USERS | 56 |
| 4-17 | TRAVEL CHARACTERISTICS OF POTENTIAL USERS AND USERS | 56 |

TABLE OF CONTENTS (Cont.)

| <u>Table</u> | | <u>Page</u> |
|--------------|---|-------------|
| 5-1 | LIFT PASSENGERS PASSED UP | 67 |
| 5-2 | ACCESSIBLE RUNS SERVICED BY A NON-ACCESSIBLE COACH . . | 68 |
| 5-3 | REPORTED REASONS FOR FAILURES TO BOARD | 69 |
| 5-4 | WHAT LIFT USERS DID AFTER BEING UNABLE TO BOARD | 70 |
| 5-5 | FEATURES REQUIRING CHANGE OR PRESENTING A PROBLEM . . . | 73 |
| 6-1 | FREQUENCY OF REPAIR | 75 |
| 6-2 | ON-TIME PERFORMANCE | 77 |
| 6-3 | SCHEDULED RECOVERY TIME | 78 |
| 6-4 | START-UP LABOR COSTS | 80 |
| 6-5 | STAFF AND OPERATOR TIME TO MAINTAIN 163-BUS ACCESSIBLE SERVICE | 81 |
| 6-6 | REPAIR LABOR AND COST FOR LIFTS | 82 |
| 6-7 | ANNUAL REPAIR COST FOR LIFTS AND OTHER SYSTEMS | 82 |

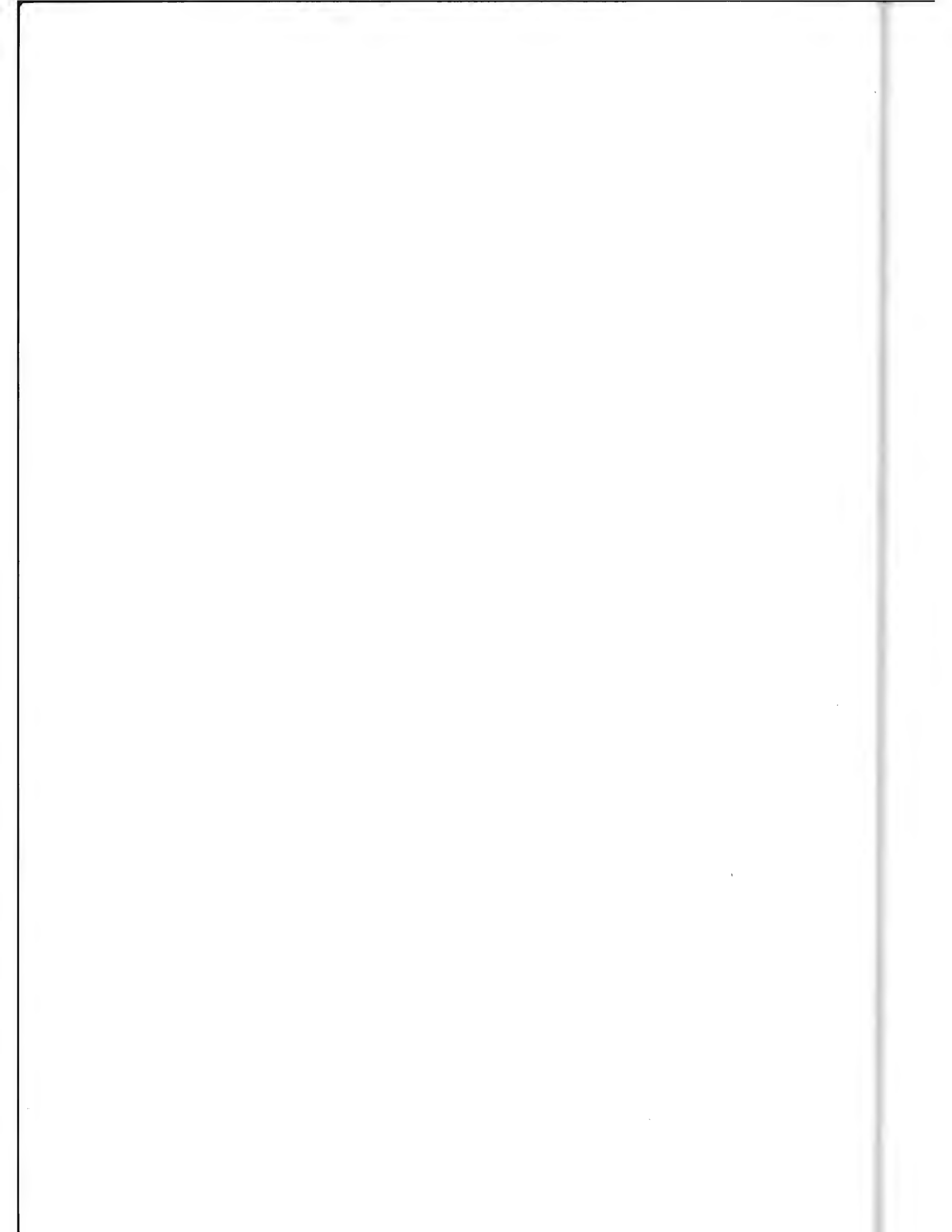

EXECUTIVE SUMMARY

INTRODUCTION

The Municipality of Metropolitan Seattle (Metro) initiated fixed-route, accessible bus service beginning in August 1979. The service has been very successful in terms of reliability and ridership, especially compared to many other accessible bus services. In order to provide information to other transit operators, and to inform the national debate over accessible transit, the Transportation Systems Center (TSC) and the Urban Mass Transportation Administration (UMTA) approached Metro about participating in a case study documenting Metro's experience. Metro agreed to participate, and to perform data collections with UMTA funding. TSC selected Crain & Associates to perform the case study.

The case study was to be based on following operations for three months in the summer of 1980, plus available data from the period preceding that. Metro conducted surveys of lift users, potential users, and drivers on accessible runs, and provided data on maintenance, ridership and schedule reliability. Most of the analysis is based on the time period and data sources just mentioned. During the report preparation, review and revision process, service expanded considerably. The report takes note of these changes where feasible.

SETTING

Metro provides transit service to most of King County, Washington (1979 population 1,231,500), including the city of Seattle. Metro operates 194 routes using a fleet of 1,047 coaches, including 151 articulated buses and 109 electric trolley buses. In August 1981 Metro had 259 lift-equipped buses and 16 lift-equipped trolley buses. Revenue ridership in 1980 was 66 million. In addition to lift-equipped, fixed-route buses, Metro funds a subsidized taxi program for the low-income elderly and handicapped. This program, The Taxi Scrip Program, provided over 50,000 rides in 1980, at prices 40% to 60% below normal taxi rates. Metro also subsidizes lift-equipped van service operated by social service agencies in parts of the county poorly served by transit and taxis.

PROGRAM DESCRIPTION

History

Metro has had a policy of accessibility on all newly purchased buses since April 1978. Even before that, in 1977, it was decided to install lifts on 109 new trolley buses then on order. These actions were taken before they were required by Federal regulations. A lift-selection process was begun after 10 test buses with lifts were found unacceptable. This process included handicapped representatives and involved traveling to sites where various lifts were in use. As a result Metro chose to use lifts made by Lift-U-Inc., also based in Seattle. Detailed criteria were developed for choosing routes to be made accessible, including providing at least hourly accessible service, preference for high-patronage routes, and balance across the service area. As service levels increased, some additional policies were adopted, including a 15% spares ratio and a requirement that all runs on an accessible route which are out at noon should be accessible. A Driver Task Force was formed, consisting of 8 to 10 drivers who met bi-weekly on Metro's time. The task force acted as a means of communication between drivers and management, and made recommendations on policy and procedures relating to lift use. All bus stop zones on accessible routes were checked for accessibility; the resulting list is available to lift users in printed form and through the telephone information office. Service was increased gradually, reaching a level of 23 routes served by 143 buses in February 1980. The next major addition came at the end of January 1981, when accessible service was provided on 42 routes using 259 buses. As of July 1981 lift-equipped trolley bus service was also being phased in, and accessible service was provided on 45 routes.

Service During the Period Studied

Between June and September 1980, when most of this evaluation was conducted, Metro offered wheelchair accessible service on from 23 to 26 of its routes, serving all parts of its service area, using 163 buses. Because of a system-wide equipment shortage, only 90 buses were scheduled for peak accessible service. Twenty accessible buses were available as spares. On weekdays, half of the accessible routes had approximately hourly accessible service and half had approximately half-hourly or more frequent accessible service, accounting for about half of all scheduled bus trips on the 23 routes. Accessible service comprised about 17% of peak scheduled coaches on all 194 routes. Weekend service was slightly less frequent.

Plans for Future Service

Metro is continuing with its policy of buying only lift-equipped coaches. In late 1981 or 1982 Metro expects to receive 202 lift-equipped articulated buses ordered from MAN of

West Germany. In addition 109 recently acquired trolley buses are being retrofitted with lifts. By the summer of 1982, all ten trolley routes will be fully accessible.

Vehicles

All accessible buses received so far are "new look" Flyers, either 35 or 40 feet long, and 102 inches wide (the wider of two standard widths). Each bus has two wheelchair securement areas, formed by folding up the first forward-facing seats, plus parts of side-facing seats. Wheelchairs can be secured by a clamp, mounted at the back of the securement area, which is designed to close around the window-side wheel when the wheelchair backs into the clamp, as well as by straps on both sides which hook on the frame of a chair. Wheelchairs must be secured on both sides using the straps, or a combination of one strap and the clamp. Seatbelts are provided. Their use is optional.

The Lift

Metro has ordered front-door Lift-U lifts on all its accessible buses. The lift can be ridden in a wheelchair or standing up, although standing passengers must duck to pass through the door opening. Metro has installed padding over the door opening to prevent injuries. Lift operation is relatively simple. One two-position toggle switch moves the lift up and down. Two other toggle switches must be depressed simultaneously to stow the lift. The lift platform is stowed under the front steps of the bus, where its outer 11 inches form the bottom steps. In use the platform moves out and swings up over the steps. Not counting passenger actions, lift cycle time is 30 seconds. The lift has various safety features, including a hinged safety gate on the outer edge of the platform and interlocks between the lift power and the bus door, brake and accelerator.

Policies and Procedures

The lift will be operated only at designated accessible stops on designated accessible runs, even though accessible buses are often used for other service. The backwards boarding position is recommended but not required for wheelchair users. Lift users are to board or deboard after other passengers. Drivers do not normally assist lift users in using the lift. However, most wheelchair users do require assistance in using the tie downs.

Driver Training and Attitudes

Of about 1,900 drivers, all 250 extra board drivers and about 200 regular drivers had been trained to operate accessible service by the end of 1980. All new operators receive lift training. If a driver wishes to sign up for an accessible run, he or she must have completed the lift training before beginning

to operate that run. The training is a two-hour program, conducted on an accessible coach with groups of four or fewer drivers. The training includes role playing, discussion, and handouts. In January 1981 a 33-minute videotape was added which shows handicapped people in different types of wheelchairs, and explains how they wish to be treated.

Drivers on accessible runs are generally supportive of the service. However, 66% described the mechanical reliability of the lift as fair or poor. Also, 62% noted that lift users need assistance tying down most of the time. The most frequently volunteered comments were generally positive remarks (22%) and a need for more recovery time in schedules (11%).

Marketing and Outreach

The lift service has not been advertised, although it has received a lot of news coverage. Most of Metro's marketing has been informational. The public learns about accessible service through seeing the accessible buses, accessibility data in schedules, lift decals at bus stops, posters on-board the buses, the telephone information service, and mailings to about 150 individuals and organizations on a mailing list. The telephone information service provides information about accessible routes and schedules, and will identify the nearest accessible stop to a caller's origin and destination. Between September 1979 and December 1980 Metro conducted 24 outreach demonstrations, during which an accessible bus was taken to schools, group residences, agencies and other locations to show it in operation and give potential riders a chance to practice using the lift.

RIDERSHIP

Ridership Levels

Lift use has been quite high compared to most other accessible bus systems. Between February and October 1980, average daily boardings were estimated at 56.* Lift use by route is roughly related to total ridership by route. Bad weather (mostly rain in Seattle) appears to depress lift use levels. To compare Seattle's lift use with data from other transit systems, the measure "proportional lift use" was used. This measure, defined as lift use as a percentage of revenue ridership on accessible routes, is intended to allow reasonable comparisons among systems offering different amounts of accessible service and serving different types of areas. Seattle's proportional lift use, .07%, is matched by Champaign-Urbana,

*After service was increased, average daily boardings rose to 125 between April and July 1981.

Illinois and AC Transit (Oakland/Berkeley, California). However it is greater than most others, including some recently-implemented systems such as Palm Beach, Florida (.04%) and Orange County, California (.03%).

Ridership Characteristics

A survey of 73 lift users showed that most lift use is by a relatively small group. Forty-eight percent of respondents accounted for 84% of reported trips. Thirty percent of lift users make 9 or more one-way bus trips per week. Most users wheel to the bus stop (86%), transfer at least some of the time (67%), and live two or more blocks from an accessible bus stop (80%). Frequent users make most of their trips for work (28%), recreation or visits (21%), personal business (16%) and shopping (16%). Infrequent users make most of their trips for shopping (36%), recreation or visits (27%) and personal business (19%).

The lift users are relatively young (84% under age 55). Many (49%) use electric wheelchairs. Only 33% ever travel with an attendant. The most frequently used other transportation modes are rides with friends or relatives (76% of respondents) and taxicabs (58%). Only 12% ever drive themselves. Thirty-eight percent use the bus for trips formerly made by getting rides, most of them in order to be more independent. Nineteen percent use the bus for trips formerly made by taxi, and 16% for trips formerly made by driving, both mostly to save money.

Potential Users

Metro interviewed 72 people who have difficulty using steps and who expressed some interest in using transit. These "potential users" were older than the users (44% over age 55) and less able to get around--69% travel with an attendant at least some of the time. The potential users live as close or closer to bus service than the users, but many have no accessible bus service near their home (25%) or do not know if there is accessible service there (32%). Lack of service is perceived as an important reason for not riding the bus. Seventy-two percent of potential users also identified physical barriers between home and the bus stop.

Explanation for Ridership Levels

Ridership in Seattle has been very high compared to what many people have come to expect from accessible bus service in most cities. Nevertheless, it may still be the opinion of many observers that 56 or even 125 average daily uses should be considered very light usage when compared to transit use statistics for services other than accessibility. Since this report is primarily concerned with evaluating Metro's experience in comparison with other accessible services, it refers to lift use in Seattle as "very high." Some readers may wish to understand this as a shorthand for "very high compared to other accessible services."

Ridership is very high in terms of total lift use. In terms of proportional lift use, two other systems match Seattle; several others are considerably below Seattle but not so far below as would be suggested by total lift use. Seattle's high proportional lift use does not appear to be due to an unusually high incidence of wheelchair users in the population. Weather and geography do not appear particularly favorable to lift-use either. It seems unlikely that especially easy-to-serve origins and destinations of potential lift users offer an explanation.

Several factors were observed which probably do explain Seattle's high proportional lift use. First, the Seattle service is much more reliable than most accessible services implemented so far. Systems such as St. Louis, three in Connecticut, and WMATA have many more denied trips and accessible runs served by non-accessible equipment than does Seattle. Second, the service was well-planned. Service levels were increased gradually; a substantial spares ratio was maintained; and implementation focused on high-ridership routes, which, it was believed, would also attract the highest levels of lift use. Also at least one major concentration of wheelchair users was served on a very usable route. Third, the service was carefully marketed. Metro avoided overselling it. Marketing consisted of news coverage, useful information, and outreach demonstrations. Fourth, management, staff and drivers have all shown a very positive attitude and a high degree of commitment to making the service work.

The factors just listed distinguish Seattle from many less successful systems. However, there are some recently-implemented systems, with no apparent major difficulties, which, nevertheless, have much lower proportional lift use than Seattle. Two such systems are Palm Beach, Florida and Orange County, California. Based on discussions with people knowledgeable about those systems and with handicapped spokespersons in Seattle, three additional factors emerge. These are a relatively accessible environment (compared to Palm Beach); the very strong support for, and participation in planning accessible, fixed-route service (compared to Palm Beach and Orange County); and the lack of any comparable, competing accessible transportation in Seattle (such as exists in Orange County).

All the factors in the preceding two paragraphs are believed to account for high proportional lift use in Seattle. This, combined with extensive accessible service and a high general level of transit use in Seattle, accounts for the relatively high levels of total lift use observed.

SERVICE QUALITY

Service Reliability

From the lift users' point of view, the service has been relatively reliable. Between February and October 1980, an average of 1.7% of passengers were passed up due to equipment malfunctions and an average of 0.7% were passed up due to overload conditions. Between June and September 1980, an average of 0.75% of scheduled accessible runs were served by non-accessible equipment. Although problems are relatively rare, 74% of lift users reported being unable to board at least once, of whom 73% said they just waited for the next bus.

Safety

Most lift users report feeling safe while waiting, while riding the lift, and while riding on the bus. There have been four or five accidents or incidents involving possible injury to lift users. The most serious incident involved a person rolling off the end of the lift. She has a claim pending against Metro, although she did not appear to be seriously injured. The remaining accidents have been comparatively minor. The evaluation contractor was not able to review any detailed records of incidents or claims. Metro staff feel their experience with accidents and claims with lift users is similar to their experience with the able-bodied.

Ease of Use

The most difficult problems in using the lift buses are getting to and from the wheelchair positions on the bus and operating the tie-down devices. Many lift users require assistance from the driver in these operations. The problems identified by the greatest number of lift users are a need for more curb cuts and a need for more bus service.

IMPACT ON METRO

Equipment Reliability

Metro staff describe the lifts as very reliable and improving. Between June and September 1980, the average lift required a repair once every 4,200 bus-miles, or once for every 11.3 lift boardings. There was one lift-related service interruption for every 35.3 lift boardings. The average time to repair a lift is estimated at 1.2 hours. An early problem was the operation of the lift safety gate. An improved design, retrofitted on all the lifts, has since solved this problem. The exposed position of the lift underneath the bus has also caused some problems, including dirt in the mechanism and damage in accidents.

Schedules

There has been no measurable impact on schedules or on-time performance. No extra recovery time was added to schedules because of accessible service. Possible reasons for the lack of impact may include the amount of recovery time already in the schedules, the fact that peak service has a lower fraction of service accessible than off-peak service, and the fact that the Flyer coaches are faster than others and can make up lost time more easily. Most drivers (84%) feel that operating the lift causes them to be behind schedule for the current trip only. However, the most frequently volunteered negative comment by drivers (11%) was that more recovery time is needed.

Cost

The Lift-U lifts added \$5,700 to the cost of the first 143 accessible coaches ordered, and about \$7,250 to the cost of later accessible coaches. Other accessibility features are estimated to have cost \$500 per bus. Total capital costs for accessibility on the 163 buses in use in the summer of 1980 are estimated at \$1,040,000.

Start-up costs were estimated for labor only. For the 163-bus level of service in place during the summer of 1980, start-up labor costs are estimated at \$171,000 for about five person-years of effort. There are continuing start-up costs for additional increments of accessible service, particularly for driver training, lift troubleshooting and installation monitoring.

Operating cost was estimated for maintenance and other staff time. There do not appear to have been any additional costs for insurance. Total staff time to maintain current service levels are estimated at two full-time equivalents costing \$61,500 per year. The major item is increased scheduling effort. According to the staff, the cost to maintain the less extensive amount of service provided with 163 buses in the summer of 1980 would not be appreciably less. Repairs on the lifts are estimated to require a little over one full-time equivalent mechanic for the 163 accessible buses, costing \$38,092 per year, or \$234 per coach per year. Adding in preventive maintenance, trouble calls and parts, total maintenance cost is estimated at \$497 per bus per year and about \$81,500 for 163 buses, or about 2.4 full-time equivalents. Combining maintenance and other staff time, total operating cost for 163 buses comes to \$143,000 per year.

Cost per trip was estimated with and without capital cost. For ridership, the figure 20,500 boardings per year was used, based on average use in the period February to October 1980. Operating cost per unlinked trip (i.e., cost per lift use), excluding capital, works out to \$6.98. Based on an estimate of 0.4 transfers per linked trip, the operating cost per linked trip is \$9.77. Capital cost was annualized using a discount factor of 10% and a life of 10 years. Annualized capital cost for 163 buses is then about \$170,000. This makes the operating plus capital cost per unlinked trip equal to \$15.27, and the same measure per linked trip equal to \$21.38. As of July 1981 it is believed that the cost per trip has fallen considerably (to \$11.12 for operating plus capital cost per unlinked trip) due to increased ridership and constant costs for staff time. In the long run, it is impossible to predict whether the cost per trip will rise or fall.

CONCLUSIONS

1. Seattle has experienced the highest total lift use of any city and high proportional lift use compared to many, but not all, other systems due to the extent and reliability of the service, good service planning and marketing, commitment on the part of Metro, the strong support and participation of the handicapped community, and a lack of any major competing accessible service.
2. The evaluation did not uncover any specific set of actions or circumstances contributing to the relatively high lift use figures in Seattle which could not be matched in other locations. Consequently, except for such externalities as significant environmental travel barriers or the existence of a major competing accessible service, there is no identified reason why other sites could not reach or exceed Seattle's level of proportional lift use, or why larger systems could not reach or exceed Seattle's level of total lift use. However, the possibility exists that some as yet unidentified factors may significantly influence the level of lift use. If this is the case, lift use statistics might be significantly higher or lower in many other locales compared to those in Seattle.
3. Seattle's lift users are younger than the general handicapped population. Many use electric wheelchairs. Few travel with an attendant. Most of the lift use is accounted for by a minority of frequent users, who use the service mostly to go to work, for recreation and visits, and to go shopping.

4. The Seattle service has been relatively reliable for users compared to most other accessible bus services in operation. Users have difficulty maneuvering in the bus and using the tie-downs. Users would like more curb cuts and more bus service.
5. Service reliability has been made possible by reliable equipment, an adequate spares ratio, consistent assignment of vehicles, and a slow buildup of service.
6. The Lift-U lifts have been mechanically reliable compared to earlier lift installations. Metro has done a good job of maintenance and has received good warranty service from Lift-U.

1. INTRODUCTION

1.1 BACKGROUND

This case study has been conducted by Crain & Associates, Inc. for the Transportation System Center (TSC). In connection with its responsibility for evaluating projects for the Service and Methods Demonstration (SMD) program of the Urban Mass Transportation Administration (UMTA), TSC carries out research on transportation developments related to the objectives of the SMD program. Transportation for disadvantaged groups, including the elderly and handicapped, is one of the major emphases of the SMD program. TSC has conducted and is now conducting evaluations of SMD projects demonstrating wheelchair-accessible bus service, and has conducted and sponsored case studies of locally-initiated wheelchair-accessible bus services. These case studies and evaluations are intended to inform the ongoing national debate over the appropriateness, feasibility and cost effectiveness of meeting handicapped transportation needs by means of providing accessible, fixed-route bus service.

The Municipality of Metropolitan Seattle (Metro) initiated fixed-route, accessible bus service as a result of local planning efforts, before such service became a requirement of Federal regulations. The service is extensive, reliable and well-used compared to many such services in other cities. Therefore, TSC and UMTA determined that it would be valuable to policy makers and other transit operators to document Metro's experience. Metro agreed to work with Crain & Associates to provide the information needed. UMTA provided financial assistance to Metro for the necessary data collections and staff time.

1.2 STUDY OBJECTIVES

Until recently, experience with lift-equipped bus service was mostly negative. The equipment was unreliable, service quality to passengers was poor, and ridership was minimal. Seattle was the first major transit operator in the United States to report what it felt was a successful lift-equipped bus service. The lift ridership levels reported were many times those experienced by any other operator. Moreover, Metro was solidly behind a program of full accessibility, regardless of the state of federal regulations. This case study was undertaken, therefore, to learn the reasons for Seattle's success. Was something done differently in Seattle than elsewhere? Could the experience be repeated, or is some unique feature of Seattle, Metro, or the handicapped community responsible?

1.3 STUDY APPROACH

To answer the questions just posed, the study undertook to document all aspects of the lift-equipped bus service in Seattle, focussing particularly on three months; June, July and August, 1980. Fortunately, Metro has very good records on many aspects of its operations in general and the lift service in particular. Metro staff were extremely cooperative in making these records available, helping to interpret them, and doing special computer runs when necessary. In addition to basic service data such as maps, timetables, and descriptions of equipment, the following Metro records were especially important:

1. Lift-use counts. Carried out once every month or two. Used to measure lift use and service reliability from users' point of view.
2. Schedule checks. Standing schedule checks carried out routinely by the Scheduling Department. Special computer tabulations of on-time performance of accessible and non-accessible runs were provided to measure the impact of lift service on schedule adherence.
3. Accounting records. Output from the accounting system for June, July and August 1980, showing labor hours and costs for each category of equipment repair, including lift repairs, was used to estimate maintenance costs for the lift and three other mechanical systems.
4. Repair records. A computerized listing of all repairs and service interruptions for June through September 1980, summarized by type of problem and bus type, was used to estimate frequency of repair for the wheelchair lift.

In addition to providing these records, Metro staff were available for interviews which were conducted during five site visits and dozens of telephone calls. Metro also conducted three surveys for this case study. They were:

1. A lift-user survey. Seventy-three lift users were interviewed by telephone or in person about their travel by bus and other modes, experiences with the lift, personal characteristics, and suggestions for change.
2. A survey of potential lift users. Seventy-two people were interviewed who have difficulty using steps or cannot use steps at all, and who

indicated an interest in riding Metro. They were questioned about their travel, personal characteristics, reasons for not using the lift, and suggestions for change.

3. A driver survey. All drivers on accessible runs received a mail-back survey asking about their experiences with lift service.

Finally, it was necessary to put Seattle Metro's experience in context by comparing it with the experience of other operators. Recent implementations of accessible service were chosen, which have been among the more successful ones before Seattle. The comparison focussed on lift ridership figures, and factors which would help explain the differences in observed ridership.

1.4 TIME PERIOD

The study was originally intended as a "slice of time" study, which would follow the lift service for three months in 1980 (June, July and August). The great majority of analyses presented here are based on these three months, and other months when the amount of lift service was essentially the same. While the process of report preparation, review and revision has been going on, however, the service has expanded considerably. The report takes note of these changes where feasible, but the earlier time period and service remain the primary subject matter.

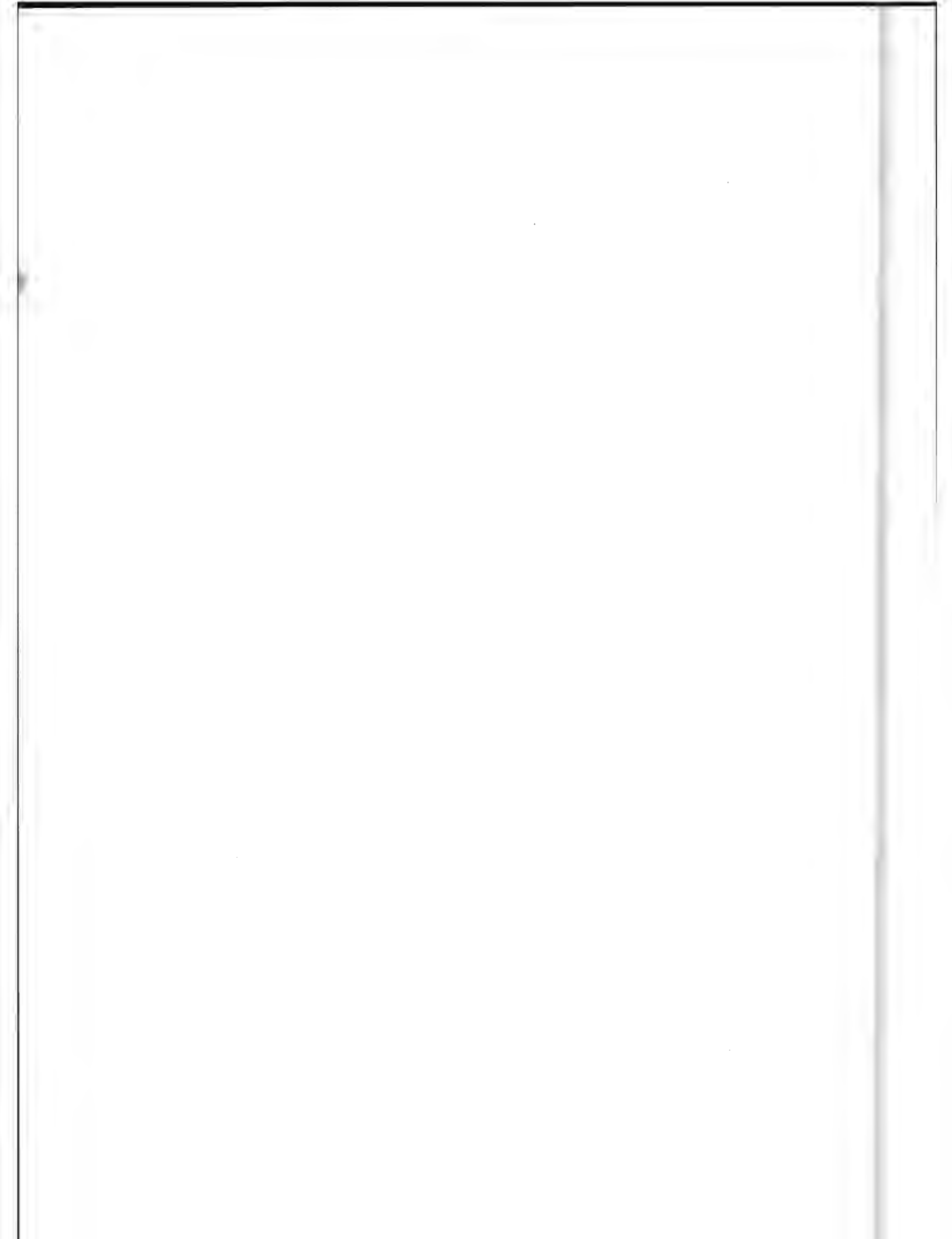

2. SETTING

2.1 GENERAL INFORMATION

Seattle, Washington is located in northwestern Washington, on Puget Sound. The terrain is hilly. The climate is relatively mild and moist. Days with temperatures above 90° in the summer, or below 32° in the winter are few. Precipitation averages 36 inches per year, of which 82% is concentrated between October and April. Winter snowfall averages a total of 9 inches; snow seldom remains on the ground more than one or two days at a time.

Seattle is the major city in King County, which covers 2,128 square miles, including 38 incorporated cities. The 1979 population of King County was estimated to be 1,231,500, mostly concentrated in the western third of the county. Development patterns within the service area vary from dense urban to sparsely populated rural.

2.2 TRANSIT SERVICE

Transit service is provided by the Municipality of Metropolitan Seattle (Metro). Metro operates transit service in most areas of King County, except some of the least densely populated rural areas. The majority of service is oriented toward the Seattle CBD, where transfer connections can be made to other parts of the system. Frequency of service varies from every ten minutes in areas close to the CBD to every 60 minutes, or only at peak hours, in the suburban and outlying areas.

The basic one-zone fare is \$.50; two-zone trips cost \$.75 while trips within the downtown area are free. Elderly and handicapped pay \$.15 for one or two zones at any time of day. Youth pay only the regular one-zone fare for any trip. Guide dogs and lap dogs ride free; all other animals pay the base for the human accompanying them (e.g., a dog accompanied by a senior or disabled person pays \$.15). Transfers are free and are good for one hour with no restriction on direction. Monthly passes cost \$19 for regular one-zone trips, \$28.50 for two-zone trips, and \$2 for elderly and handicapped.

Metro operates 194 routes using a fleet of 1047 coaches, including 151 articulated buses and 109 electric trolley buses. In August of 1981, Metro had 259 lift-equipped buses and 16 lift-equipped trolleys. (As of 1979, the 10 trolley bus routes were served by diesel buses pending renovation of the overhead

power network. During late 1980 Metro began restoring trolley bus service.) Twenty-one permanent park-and-ride lots are located throughout Metro's service area providing 8452 parking stalls. Thirty interim (temporary) park-and-ride lots provide 2274 additional parking stalls. Passenger shelters have been installed at 1026 of Metro's 7,800 bus stops. Metro's 1980 operating expenditures were \$77 million.

In 1980, Metro carried over 66 million passengers, an increase of 17% over the previous year. The growth rate is expected to be much lower for the next two or three years. Table 2-1 shows the growth rate in passengers, vehicle hours, and vehicle miles for 1974-1980. Express trips accounted for 21.6% of 1979 average weekday bus hours. Fifty-eight percent of average weekday ridership was in the AM and PM peak hours (four hours). Reduced fare passengers (elderly or disabled people) accounted for 14% of the total ridership.

Most neighborhoods within the Seattle city limits feature sidewalks and curbs except for the area north of 85th Street, parts of the southeast section, and West Seattle. In suburban and rural areas, paved sidewalks are rarely seen outside of business and shopping areas. The City of Seattle is following an aggressive curb cut program in the CBD, neighborhood shopping and business centers, and the hospital area.

2.3 ELDERLY AND HANDICAPPED TRANSPORTATION

Based on national statistics, Metro's service area would include approximately 68,000 transportation handicapped persons, of whom about 2,000 would be wheelchair users.* Metro's Elderly and Handicapped Transportation Policy calls for serving this population with fully accessible fixed-route transit, as well as a Special Transportation Service Program (STSP) to supplement transit where inadequate. The STSP is funded by up to 5% of Metro's UMTA Section 5, Tier I allocation. The City of Seattle, King County, the Puget Sound Council of Governments and citizen committees participated in program planning. This program was formally adopted by the Metro Council in September, 1978. The purpose of the STSP is to provide access to Metro's facilities and services, provide transportation when Metro's facilities and services are inadequate, and to integrate transit with other transportation resources by making use of existing taxi and van services. The program is open to people who are age 65 and older

*National Survey of Transportation Handicapped People, UMTA, Washington, D.C., 1979. Transportation-handicapped were estimated as 5.5% of non-institutional population in mass transit areas. Of transportation handicapped surveyed, 3% were in wheelchairs.

TABLE 2-1. METRO SERVICE CHARACTERISTICS, 1974-79

| | 1974 | 1975 | 1976 | 1977 | 1978 | 1979 | 1980 |
|------------------------------------|------------|------------|------------|------------|------------|------------|------------|
| <u>Annual Operating Statistics</u> | | | | | | | |
| Total Revenue | | | | | | | |
| Passengers | 35,468,000 | 38,001,000 | 41,464,000 | 44,905,000 | 49,460,654 | 56,259,153 | 66,071,730 |
| Total Revenue | | | | | | | |
| Vehicle Hours | 1,576,306 | 1,725,000 | 1,778,000 | 1,803,000 | 1,870,129 | 2,023,838 | 2,269,442 |
| Total Revenue | | | | | | | |
| Vehicle Miles | 21,289,687 | 23,337,269 | 24,092,678 | 24,301,151 | 25,573,365 | 27,619,332 | 31,691,419 |

7

or handicapped. An additional low income requirement (at or below 70% of the state median household income) was also imposed. In April 1980 the low income restriction was removed for disabled people; however, in September 1981 it was reinstated. The STSP offers a cab fare subsidy (taxicab scrip) county-wide. In the south and northeast rural and suburban portions of the county, where both taxi and transit service are limited or non-existent, the program works through two nonprofit van operators to increase the availability of transportation.

When eligible people register they receive a Metro Reduced Fare Permit which allows them to ride the bus at a reduced fare, with an STSP identification number on the back. The pass costs \$1.00 and is good for the person's lifetime. People already possessing a reduced fare permit simply have an identification number added at no fee.

The Taxicab Scrip Program was implemented December 1, 1978. Registered people can purchase a \$10.00 booklet of taxi scrip for \$4.00 and use the scrip to pay regular cab fare with any participating cab company.* The three major cab companies in King County, plus a number of the smaller companies and independent operators, accept Metro scrip. Two companies operate lift-equipped taxi vans in addition to their regular sedan fleets. There are no limits on frequency or trip purpose of scrip use. In 1979, the program's first full year of operation, 3,700 people registered and took over 19,000 cab rides using scrip with an average fare of \$3.97. The program cost Metro \$30,500 in 1979. In 1980 over 50,000 rides were taken by scrip users. The average fare was \$5.40; the program cost Metro \$165,000 in scrip subsidies.

Metro support of the van programs began in April 1979, in the south portion of the county, and September 1979, in the northeast. Two agencies operate 16 lift-equipped vans. People within the van service areas who wish a ride call the agency one to three days in advance to reserve a place. Metro pays the agencies a portion of the trip cost for each person carried who is registered for the STSP. Passenger fares and other funding sources, including the Seattle-King County Division on Aging, King County Developmental Disabilities Board, United Way, and Community Services Administration pay the remaining cost of transportation. In 1980, 33,000 Metro-supported rides were given at a cost to Metro of \$73,000.

*The price was originally set at \$6.00, then reduced to \$4.00 in June 1980. As of September 1981, Metro raised the price to \$5.00.

3. PROGRAM DESCRIPTION

This chapter begins with a chronological account of the program in three sections: history (Section 3.1), the extent of service in place during the period studied (Section 3.2), and plans for future service (Section 3.3). The following four sections provide a more detailed discussion of particular aspects of the program, namely the equipment used (Sections 3.4 and 3.5), policies and procedures (Section 3.6), driver training and attitudes (Section 3.7), and marketing and outreach (Section 3.8).

3.1 HISTORY

3.1.1 Background

Metro has been planning for accessible fixed-route service since 1977. A 1976 Elderly and Handicapped Transportation Study had recommended concentrating on paratransit. However, in working with citizens and representatives of public agencies following the study, a new consensus in favor of accessible, fixed-route service emerged. In 1977 a decision was made to install lifts on 109 new trolley buses which were being ordered as part of a renovation program of ten electric trolley bus routes.

In April 1978 Metro officially adopted a policy that all new buses would be accessible, in addition to which up to 5% of Metro's UMTA Section 5 assistance would be spent on special service. At that time, the 504 regulations requiring fixed-route accessibility were still not final, although draft regulations had been published. There was no state requirement for accessibility either. Thus Metro's action reflects an independent commitment, and a desire, in the words of a staff member, to "get the jump on Federal regulations."

3.1.2 Equipment Testing and Selection

In order to test lift-equipped service, ten AM General diesel buses were ordered with lifts manufactured by Transportation Design and Technology, Inc. (TDT) of San Diego. The ten test coaches arrived in August, 1978. However, the lifts installed in the coaches were determined to be unacceptable in terms of usability by the disabled and Metro's operational concerns, so the ten test buses were never used for accessible service.

Metro then started a nationwide investigation of the wheelchair lifts available for installation in transit coaches suitable for regular transit service. Representatives of the Washington Coalition of Citizens with Disabilities actively participated in the search. An observer from Flyer Industries, Ltd. of Canada, which had recently been awarded a contract for 143 new diesel coaches, also participated. The search resulted in selection of the lift manufactured by Lift-U-Inc. of Seattle, which is now being used in accessible service. The Lift-U lift had been designed by a former Metro staff member, and was in use on a special bus serving Center Park, a Federally-subsidized accessible housing development in Seattle. Flyer agreed to install the lifts on the order of 143 diesel coaches, which began arriving in the spring of 1979. A second order of 116 Flyers with Lift-U lifts was also placed. Of the second order, 20 arrived in the summer of 1980 and were put into service. Negotiations with the supplier of the 109 trolley buses resulted in an agreement to delete the TDT lifts which had been ordered from all but 30 trolley buses which were already in production. Most of the trolley buses have now been retrofitted with Lift-U lifts.

3.1.3 Service Planning

Metro Staff, with the active participation of citizens, and staff of King County and the City of Seattle Department of Human Resources, developed criteria for the route assignment of the ten lift-equipped diesel test coaches. The criteria specified such things as safety, service level, patronage, geographic coverage and connections with trolley routes, which would be accessible after retrofitting 109 AMG trolley buses with lifts. The trolley routes were being served by buses on a temporary basis. Since they would be accessible once trolley service was resumed, they were excluded, for the most part, from the route selection process described below.

Route selection for the Flyer coaches started using the criteria developed for the "ten-bus" test program. However, it soon became clear that with the much larger number of vehicles involved, a different approach would be required. Emphasis was on creating a balanced and integrated system which would allow people dependent on the lifts to go anywhere Metro goes within the limits set by the amount of accessible equipment and geographic conditions.

Three factors emerged as the most important in selecting routes. These were:

1. Hourly headways. Accessible service should be provided at approximately one-hour headways on selected routes to provide a convenient level of service

while spreading accessible buses to as many routes as possible.

2. High patronage. Mobility-impaired people live scattered throughout the general population. Therefore, the more people riding a bus, the more disabled people are likely to ride it.
3. Balance and spread of service areas. The combination of routes selected should cover as much of Metro's service area as possible to be capable of serving a range of transportation needs.

These factors produced a priority list of routes to be made accessible. The routes to be made accessible with the initial 143 buses included route 7, which is a trolley route. Route 7 was considered a special case because it serves Center Park, an accessible housing development, and several popular destinations as well. In the summer of 1980 planning began for the assignment of the second order of Flyer coaches, scheduled to begin operating accessible service in January 1981. The same factors were used to prioritize routes. However, to eliminate operational problems experienced in the first year of accessible service, Metro staff adopted the following additional principles:

1. Each maintenance base should have at least 15% spare accessible coaches.*
2. All routes with Flyer coaches assigned to them should be accessible.
3. All runs which are out at noon should be accessible.

Notice that these principles did not apply to planning most of the service discussed in this report. They were applied to all service beginning in January 1981.

3.1.4 The Driver Task Force

A Driver Task Force was established as a support and resource group consisting of 8 to 10 operators, representing all the operating bases, who volunteered because of their interest in accessible service. The operators attended the Task Force meetings once every two weeks, on Metro's time, beginning immediately after the start of accessible service. After about a year, the Task Force members decided to discontinue regular meetings because there were no longer significant problems

*Metro hopes to be able to lower the spares ratio as they gain experience with the accessible equipment.

with the service. The members continued to communicate with each other for some time, and were frequently detailed to perform special tasks concerning accessibility.

The Task Force provided recommendations for service, equipment and procedure improvements and assisted in driver/management communications. The members also gathered information from other drivers and were available as an information resource at each base. The Task Force wrote articles about accessible service, discussing policies, problems, successes, and commendations from riders. The articles were included in the Base Operations Bulletin, an information sheet on matters concerning the drivers, which is posted periodically at each base. Members of the Task Force also participated in outreach demonstrations. They also met directly with disabled passengers who had concerns or suggestions about the program. Division 587 of the Amalgamated Transit Union took a strong position that this Task Force play an active role in making changes or additions to the program.

Metro has formed driver task forces on a variety of issues over the years. They are self-governing groups, with elected leaders. In management's opinion, the Driver Task Force on accessibility was a particularly active and effective group. One of its members was a driver who was detailed to work fulltime on the accessibility program, and who acted as liaison between the Task Force and the administrative staff. She continued to work on accessibility issues until January 1981, a year and five months after initiation of accessible service. The Task Force had a high level of visibility and support among the drivers. Of drivers on accessible service surveyed, 69% were aware of the Task Force and felt that it had been beneficial.*

3.1.5 Initiation of Service

After the planning for initial service was completed and the buses were due to arrive, there appeared to be a need for a coordinator for the implementation stage. A project manager for implementation was named and given authority to implement the already planned policies. The project manager's function included keeping staff at all levels informed of plans and giving immediate attention to their problems and concerns. She was responsible for bringing the union into the process early. Metro was able to get the union to agree to an important change in work rules in return for agreeing to sponsor and listen to the task force of drivers described in the previous section.

Activities in the period immediately prior to initiation of accessible service included a program of marking accessible bus zones, preparation of timetables, agreement with local 587 of the Amalgamated Transit Union about driver responsibilities,

*See note on Driver Survey in Section 3.7.1

operator training, orientation for other Metro personnel (service supervisors, coordinators and telephone information operators), a low-key publicity effort, distribution of a Lift Bulletin to those on a mailing list, and outreach demonstrations of the use of the lift. Experience in demonstrating the lift showed the need to modify the tie-down apparatus and add head guards over the door frames. All these activities are on-going, and are described in more detail in subsequent sections of the report.

Each zone on a route scheduled for accessible service was examined with a lift coach to determine if the zone is accessible. If the zone meets the criteria, a sign post wheelchair emblem is wrapped around the post. The emblem is reflectorized and visible from all sides. Some reasons for a zone failing to meet the criteria would be lack of room for the lift to extend, coach stopped in an unsafe position in traffic in order to use the lift, obstacles to deploying the lift such as shrubs, fences, or street or sidewalk crown. Initially the zones determined to be accessible were marked with a blue paint mark on the ground in a spot where the lift could be correctly and safely deployed. This paint mark was for the operator to assist in coach/lift alignment. However, once operators became more familiar with the physical requirements of lift use, the paint mark was replaced with the sign post emblem, which is more quickly recognized by operators and the public.

Accessible service began with two routes in August 1979, increasing to six routes in September 1979. Service was added throughout the winter of 1979-80, reaching a level of 23 routes after all 143 buses in the initial order of accessible Flyers had been received. One more route and 20 more buses were added during the summer of 1980. With the fall service change in September 1980, accessible service became available on 26 routes. On January 31, 1981, following receipt of all the buses in the second order of 116 Flyers, service was added to 16 more routes for a total of 42. By July 1981, lift-equipped trolley buses had taken over from diesel buses on the one trolley route already implemented (route 7); a total of 45 routes were accessible.

3.2 EXTENT OF SERVICE

Between June and September 1980, when most of this evaluation was conducted, Metro offered wheelchair accessible service on from 23 to 26 of its routes, serving all parts of its service area, as shown in Figure 3-1. On weekdays, half of these had approximately hourly accessible service and half had approximately half-hourly or more frequent accessible service, accounting for about half of all scheduled bus trips on the 23 routes. Accessible service comprised about 17% of peak scheduled coaches on all 194 routes. Weekend service was slightly less frequent. Table 3-1 and 3-2 summarize the frequency of service and fraction of service which was accessible on each route.

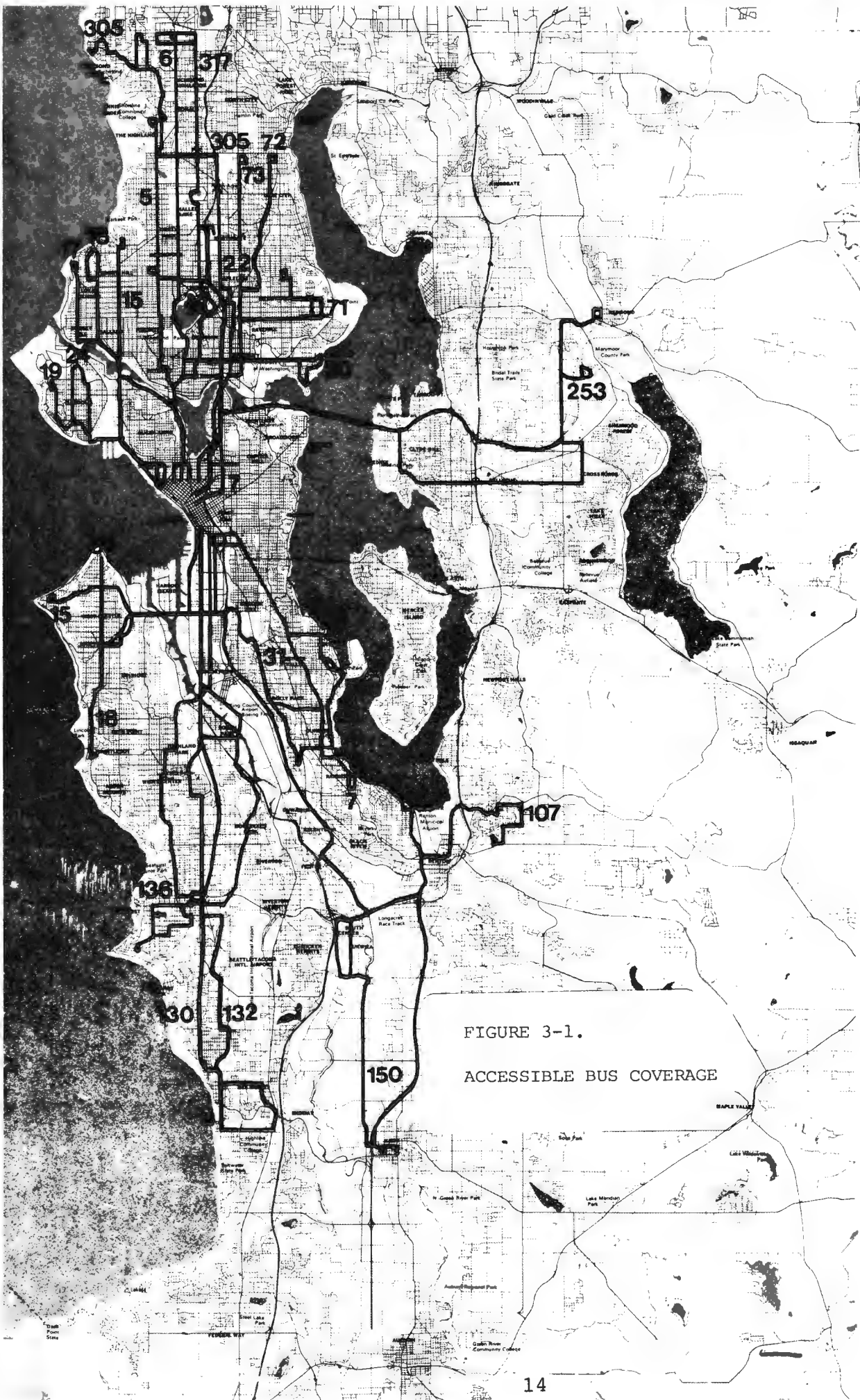

FIGURE 3-1.
ACCESSIBLE BUS COVERAGE

TABLE 3-1. FREQUENCY OF ACCESSIBLE SERVICE BY ROUTE
(SUMMER 1980)

| Route | WEEKDAY | | | | | | | SATURDAY | | | SUNDAY | | |
|-----------|--------------|-------------|----------------------|---------|--------|--------|--------------|-------------|-----------------|--------------|-------------|-----------------|--|
| | First Bus | Last Bus | Avg. Headway (Mins.) | | | | First Bus | Last Bus | Avg. Headway | First Bus | Last Bus | Avg. Headway | |
| | | | AM-Peak | PM-Peak | Midday | Eve | | | | | | | |
| 5 | 5:25 | 1:15 | 21 | 27 | 32 | 39 | 7:30 | 1:15 | 37 | 6:30 | 1:15 | 30 | |
| 6 | 5:55 | 1:15 | 28 | 19 | 39 | 30 | 6:30 | 1:15 | 30 | 6:30 | 1:15 | 30 | |
| 7 | 5:15 | 2:10 | 30 | 24 | 22 | 29 | 6:30 | 1:40 | 25 | 6:30 | 2:10 | 30 | |
| 15 | 5:45 | 1:05 | 37 | 32 | 56 | 30 | 7:45 | 1:05 | 42 | 6:39 | 1:05 | 43 | |
| 16 | 5:40 | 1:15 | 18 | 24 | 39 | 30 | 6:30 | 1:15 | 30 | 6:30 | 1:15 | 30 | |
| 17 | 6:25 | 1:15 | 37 | 20 | 51 | 52 | 9:15 | 1:15 | 53 | 6:45 | 1:15 | 53 | |
| 18 | 5:30 | 1:05 | 53 | 24 | 45 | 30 | 6:30 | 1:05 | 30 | 6:30 | 1:05 | 30 | |
| 19 | 5:55 | 11:30 | 1 trip | 36 | 78 | 56 | 8:00 | 1:05 | 60 | 6:30 | 11:30 | 60 | |
| 22 | 5:59 | 12:06 | 39 | 1 trip | 42 | 59 | 6:30 | 12:15 | 44 | 6:30 | 12:15 | 46 | |
| 24 | 5:55 | 11:30 | 31 | 46 | 49 | 52 | 6:45 | 1:05 | 61 | 6:30 | 11:30 | 60 | |
| 31 and 39 | 6:38 | 5:46 | 13 | 34 | 50 | 34 | 7:20 | 5:20 | 55 | - | - | - | |
| 30 | 5:55 | 1:01 | 18 | 27 | 30 | 60 | 6:46 | 1:01 | 35 | 6:43 | 1:01 | 36 | |
| 55 | 6:25 | 12:15 | 22 | 32 | 33 | 37 | 6:30 | 1:15 | 36 | 6:30 | 1:15 | 32 | |
| 71 | 6:10 | 5:41 | 15 | 1 trip | 1 trip | - | 6:45 | 12:00 | 30 | 6:45 | 12:00 | 30 | |
| 72 | 6:58 | 9:15 | 30 | 45 | 129 | 75 | 6:38 | 12:15 | 42 | 7:15 | 12:15 | 60 | |
| 73 | 6:46 | 12:39 | 10 | 15 | 15 | 50 | 6:20 | 11:39 | 35 | 6:30 | 11:45 | 60 | |
| 107/108 | 5:36 | 5:40 | 32 | 23 | 72 | 23 | - | - | - | - | - | - | |
| 130 | 6:37 | 7:30 | 1 trip | 1 trip | 100 | 1 trip | 6:30 | 8:30 | 105 | 6:30 | 7:30 | 111 | |
| 132 | 7:12 | 12:00 | 29 | - | 150 | 60 | 7:00 | 12:00 | 79 | 7:30 | 11:30 | 76 | |
| 136 | 5:56 | 1:05 | 31 | 32 | 105 | 54 | 7:00 | 12:00 | 60 | 7:00 | 1:05 | 64 | |
| 150 | 6:24 | 11:59 | 64 | 33 | 56 | 75 | 6:33 | 11:33 | 60 | 7:33 | 11:33 | 60 | |
| 155 | 6:12 | 10:08 | 52 | 52 | 86 | 60 | 9:38 | 7:08 | 62 | 12:43 | 5:20 | 62 | |
| 253 | 7:11 | 8:00 | 32 | 1 trip | 47 | 99 | - | - | - | - | - | - | |
| 305 | 7:42 | 11:15 | 23 | 38 | 60 | 90 | 7:30 | 11:45 | 76 | 7:00 | 11:15 | 72 | |
| 317 | 7:20 | 5:50 | 40 | 45 | 59 | 45 | 7:08 | 11:47 | 59 | 7:08 | 7:47 | 59 | |

15

TABLE 3-2. FRACTION OF SERVICE ACCESSIBLE BY ROUTE (APRIL 1980)

| Route | WEEKDAY TOTAL | | AM PEAK | | PM PEAK | | SATURDAY | | SUNDAY | |
|--------------|---|-----------------|--------------------|-----------------|--------------------|-----------------|------------------------------|-----------------|--------------------|-----------------|
| | Trips (Acc/Tot) | % Acc. Trips | Trips (Acc/Tot) | % Acc. Trips | Trips (Acc/Tot) | % Acc. Trips | Trips (Acc/Tot) | % Acc. Trips | Trips (Acc/Tot) | % Acc. Trips |
| 5 | 94/193 | 49% | 8/22 | 36% | 9/23 | 39% | 72/87 | 82% | 67/83 | 80% |
| 6 | 77/105 | 73 | 10/19 | 53 | 11/18 | 61 | 76/76 | 100 | 76/76 | 100 |
| 7 | 102/220 | 46 | 10/32 | 31 | 10/31 | 32 | 68/167 | 41 | 48/115 | 42 |
| 15 | 68/117 | 58 | 8/16 | 50 | 9/17 | 53 | 54/78 | 69 | 55/79 | 69 |
| 16 | 73/104 | 70 | 10/10 | 53 | 9/18 | 50 | 77/77 | 100 | 77/77 | 100 |
| 17 | 46/91 | 51 | 4/12 | 33 | 2/13 | 21 | 47/75 | 63 | 45/73 | 62 |
| 18 | 77/112 | 69 | 6/16 | 38 | 8/15 | 53 | 78/82 | 95 | 79/79 | 100 |
| 19 | 32/79 | 43 | 2/8 | 25 | 4/10 | 40 | 37/77 | 48 | 38/79 | 49 |
| 22 | 51/95 | 54 | 6/9 | 67 | 5/11 | 45 | 51/76 | 67 | 48/72 | 67 |
| 24 | 35/82 | 43 | 4/10 | 40 | 1/8 | 13 | 38/76 | 50 | 38/79 | 48 |
| 30 | 55/96 | 58 | 4/16 | 25 | 4/10 | 40 | 78/78 | 100 | 76/76 | 100 |
| 31 | 27/61 | 44 | 7/10 | 70 | 4/12 | 33 | 25/50 | 50 | - | - |
| 39 | Service on this route provided by Routes 31 and 7 | | | | | | | | | |
| 55 | 56/122 | 46 | 8/17 | 47 | 5/20 | 25 | 63/94 | 67 | 78/78 | 100 |
| 72 | 49/79 | 62 | 6/10 | 60 | 6/11 | 55 | 46/67 | 69 | 34/41 | 83 |
| 107 | 22/62 | 35 | 5/10 | 50 | 2/12 | 17 | No accessible service | | | |
| 130/132 | 49/119 | 41 | 7/15 | 47 | 5/23 | 22 | 48/76 | 63 | 46/77 | 60 |
| 136 | 36/118 | 31 | 3/15 | 20 | 4/18 | 22 | 37/78 | 47 | 37/79 | 47 |
| 150 | 37/64 | 58 | 4/6 | 67 | 3/7 | 43 | 34/55 | 62 | 35/49 | 71 |
| 253 | 17/66 | 36 | 4/17 | 24 | 2/16 | 13 | Does not operate on weekends | | | |
| 305 | 34/49 | 69 | 4/7 | 57 | 5/10 | 50 | 30/38 | 79 | 29/37 | 78 |
| 317 | 23/48 | 40 | 3/9 | 33 | 4/6 | 67 | 36/36 | 100 | 36/36 | 100 |
| Total | 1060/2082 | 51% | 123/286 | 43% | 112/309 | 36% | 995/1443 | 69% | 942/1285 | 73% |

3.3 PLANS FOR FUTURE SERVICE

Metro is continuing with its policy that all new buses which it buys will be lift-equipped. The 109 recently-acquired electric trolley buses are being retrofitted with lifts. Plans call for 8 of 10 trolley routes to have all day-base runs* accessible after September 1981, the remaining 2 trolley routes to have all day-base runs accessible after February 1982, and all trolley service to be accessible by the summer of 1982. In early 1980 Metro placed an order for 202 articulated buses from MAN of West Germany, which will also be equipped with lifts. The articulated buses are expected to begin arriving in late 1981 through 1982.

Many bus stop zones need improvements. To be fully accessible, a zone must have a curb cut at the corner, or no curb, and a paved walkway easily negotiated in a wheelchair from the corner to the bus stop. However, some zones not meeting these standards but which can safely be used, are marked with the accessibility decal. Zones not meeting the standards have been given priority ratings from one to four reflecting the importance of making them fully accessible. Local jurisdictions have been asked to make the necessary changes, such as curb cuts, paved walkways from the nearest corner, loading pads, and culvert covers. The City of Seattle has an aggressive curb cut program, and has committed itself to spending \$800,000 in F.A.U.S. funds on curb cuts and other bus zone improvements. So far there are still priority-one zones which remain to be brought up to the standard for full accessibility.

3.4 VEHICLES

3.4.1 General

Most of this evaluation was conducted during the late summer of 1980, when Metro had a total of 163 accessible buses with front-door lifts. The buses were manufactured by Flyer Industries, Ltd. of Winnipeg, Canada. They are all of the older, "new look" design. Thirty-five are 35-foot buses with seating for 39 passengers when neither wheelchair station is in use. The remainder are 40-foot buses with seating for 45 passengers when neither wheelchair station is in use. All are 102 inches wide, which is the wider of two standard coach widths.

Of the 163 accessible buses, 53 had to be scheduled for non-accessible service due to a system-wide equipment shortage.

*A day-base run is any run which is out at noon.

Peak scheduled service required 90 buses, leaving 20 as spares. This would indicate a spares ratio of 22%. However, the effective spares ratio was probably lower, because the accessible buses were often used as spares for non-accessible service. In addition, some bases had a smaller percentage of spares than others. No base was to have less than 10% spares.

The buses are identifiable as being accessible by the international accessibility symbol on the front and near the front door, and the legend "Wheelchair Lift Equipped" on the front. In addition the Flyer buses are easily distinguished from the rest of Metro's fleet by their general appearance.

3.4.2 Wheelchair Stations and Securement

Each bus has two wheelchair stations, in the same space as the first forward-facing seat on either side. These seats fold up, leaving the space for the wheelchair and forming the surface to which the wheelchairs are secured. In addition, parts of the side-facing seats also fold up to provide room for wheelchairs. If both wheelchair positions are occupied the seating capacity of the bus is reduced by seven. No seating for passengers was lost in reconfiguring the bus interior to provide the two wheelchair stations. The interior layout is diagrammed in Figure 3-2.

There are two systems used for securing wheelchairs. One is the "claw clamp" attached to the fold-up seat which provides the back of each wheelchair station (see Figure 3-3). In theory this clamp locks around one wheel of the chair, closing automatically when the wheel is backed firmly into it. The vertical lever, clearly visible in Figure 3-3, releases the clamp. In practice many electric wheelchairs do not fit into the clamp, or else the wheelchair users find it difficult to use. Moreover, securing the chair on only one side proved inadequate to prevent movement.

The second securement system was designed and installed by Metro after the limitations of the claw clamps were discovered during the early stages of service implementation. It consists of two straps ending in S-shaped hooks. The hook can be attached to some part of the frame of a wheelchair; then the strap is pulled tight to hold the chair in place. Chairs are required to be secured on both sides, either by straps on both sides, or else by the clamp on one side and a strap on the other side. A seat belt is also available; however its use is optional.

3.5 THE LIFT

3.5.1 General

All of Metro's accessible buses are equipped with lifts manufactured by Lift-U-Inc. of Seattle, Washington and installed by Flyer. The process leading to selection of the Lift-U lift

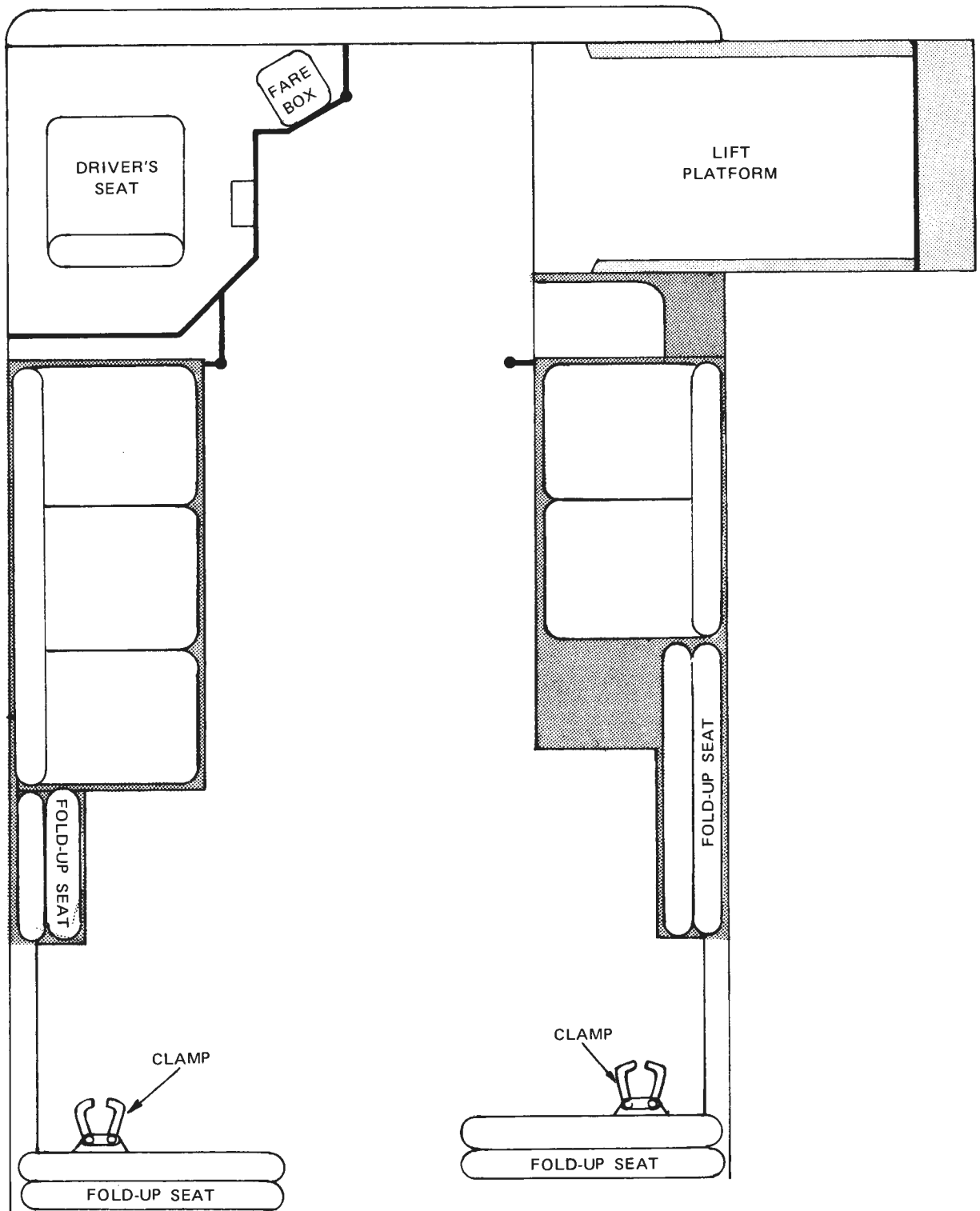

FIGURE 3-2. INTERIOR LAYOUT OF ACCESSIBLE BUS



FIGURE 3-3
WHEELCHAIR POSITIONS
WITH SECUREMENT
DEVICES

was described in Section 3.1.2. The lift has side railings, and can be used by a person in a wheelchair (see Figure 3-4) or a person standing up (see Figure 3-5). Most people who ride the lift standing have to duck to pass through the bus door opening, since the vertical clearance is only five feet (see Figure 3-6). Metro has installed padding over the door opening, on the inside and outside of the bus, in order to prevent injuries to standing lift users. The usable area of the lift platform is approximately 48 inches long and 29 inches wide. When deployed the lift extends four feet from the side of the bus.



FIGURE 3-4. RIDING THE LIFT IN A WHEELCHAIR



FIGURE 3-5. RIDING THE LIFT
IN A STANDING POSITION



FIGURE 3-6. DUCK TO ENTER

3.5.2 Boarding and Deboarding Operation

The Lift-U lift differs in its design and operation from the lifts of most other U.S. manufacturers now in widespread transit use. The lift mechanism is separate from the bus steps, except for the bottom step, which is formed by the outer 11 inches of the stowed platform. Figure 3-7 illustrates the operating concept, including the lift positions when stowed and in use. The numbering in the figure is for the boarding sequence. Position 1 is the stowed position. The controls, which are simple compared to many lift controls, are illustrated in Figure 3-7.

Each accessible bus has a decal summarizing lift operation applied to the run card holder, which is always clearly visible to the driver. The decal is shown in Figure 3-8. In order to board a passenger, the operator turns on the lift power (not shown) and holds the middle toggle switch in the DOWN position. The platform moves from position 1 (stowed) out to position 2 and then down to the ground in position 3. After the passenger has boarded the lift, the operator holds the middle toggle switch in the UP position, causing the platform to move back up through position 2 to position 4 level with the bus floor. After the passenger is in the bus, the operator presses both STOW switches simultaneously, causing the lift to move back down to position 2 and then to position 1 (stowed). The boarding sequence is further illustrated in the photographs in Figure 3-9.

In order to unload a passenger, the operator holds the middle toggle switch in the UP position. The platform moves from position 1 (stowed) out to position 2 and then up to position 4, where it is even with the bus floor. After the passenger has moved out onto the lift, the operator holds the middle toggle switch in the DOWN position, causing the platform to move back down through position 2 to position 3, on the ground. After the passenger has gotten off the platform, the operator presses both STOW switches simultaneously, causing the lift to move back up to position 2 and then to position 1 (stowed). Figure 3-7 summarizes the boarding and deboarding procedures.

The lifts in use in Seattle are set to move between the bus floor (position 4) and the ground (position 3) in about seven seconds. Movement between the stowed position (1) and the ground (position 3) takes about 11 seconds; and between the stowed position (1) and the bus floor (position 4) about 12 seconds. The loading or unloading sequence (lift cycle time) adds up to about 30 seconds, not counting time for passenger actions. The lift cycle time is adjustable using hydraulic flow valves. According to Lift-U the cycle time can be set as low as 20 seconds or as high as 60 seconds.

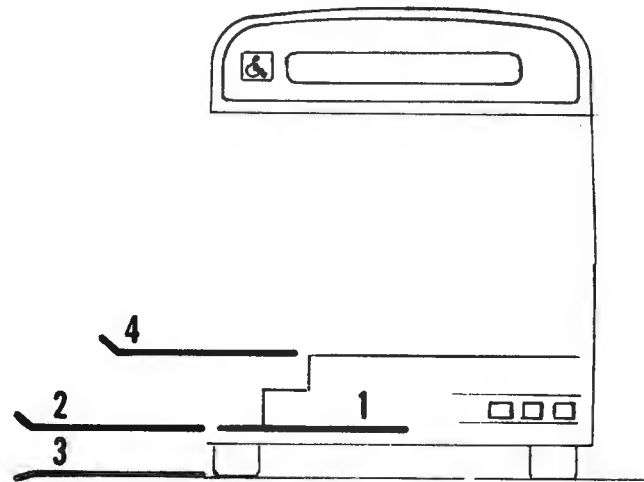

LIFT POSITIONS

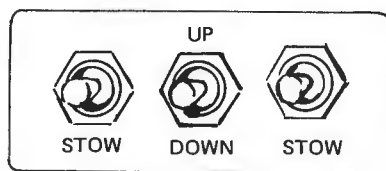

LIFT CONTROLS

24

| | CONTROL ACTION | LIFT POSITIONS | PASSENGER |
|------------|----------------|----------------|-----------------|
| Boarding | — | 1 | Waiting |
| | Press Down | 2,3 | On Platform |
| | Press Up | 2,4 | Enters Bus |
| | Press Stow | 2,1 | — |
| Deboarding | — | 1 | On Bus |
| | Press Up | 2,4 | On Platform |
| | Press Down | 2,3 | Leaves Platform |
| | Press Stow | 2,1 | — |

FIGURE 3-7. LIFT OPERATING CONCEPT AND CONTROLS

LIFT OPERATION

1. Set emergency brake
2. Put coach in neutral
3. Activate 4-way flashers
4. Activate lift-power switch

TO DEBOARD PASSENGERS

- a. Press UP switch
- b. Passenger on ramp
- c. Press DOWN switch
- d. Passenger deboards
- e. Press both STOW switches

TO BOARD PASSENGERS

- a. Press DOWN switch
- b. Passenger on ramp
- c. Press UP switch
- d. Passenger enters coach
- e. Press both STOW switches

5. De-activate lift-power switch

FIGURE 3-8. RUN CARD DECAL



FIGURE 3-9. LIFT
OPERATION--BOARDING
SEQUENCE

3.5.3 Mechanical Principles

The mechanical principles of the lifts are illustrated in Figure 3-10, which is taken from Lift-U-Inc.'s promotional brochure. A chain drive turns four sprockets, two on either side, which are attached to the side arms and raise the platform when it is deployed as illustrated. To lower the lift, the chain is let out, and the platform is lowered by gravity. The thread screw-jack, or worm gear, moves the platform assembly in and out of the stowed position under the bus steps. The lift is electrically controlled and hydraulically driven. Hydraulic power is obtained from the power steering system.

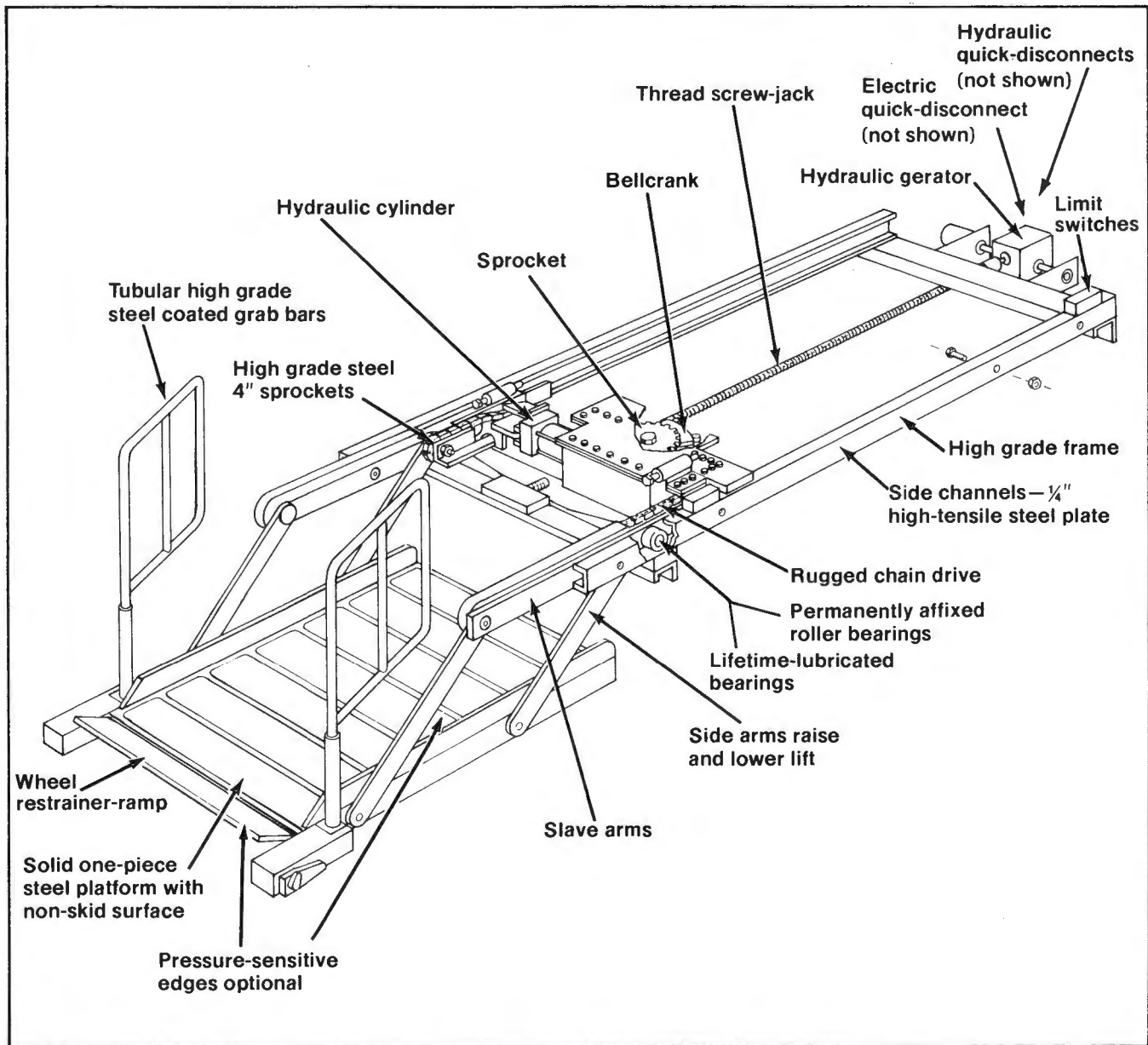

FIGURE 3-10. MECHANICAL PRINCIPLES OF LIFT-U LIFT

3.5.4 Safety Features

The end of the lift has a seven-inch safety gate, a lip which is raised whenever the lift is not stowed or deployed on the ground. The gate is intended to prevent a wheelchair from rolling off the lift. As delivered to Metro, the safety gate was controlled by a hair trigger switch on the underside of the lift. This device proved unreliable in operation. It has been replaced by a mechanism which allows the gate to drop when slack in the chain drive is sensed and the lift is below the position from which it can be stowed (position 2 in Figure 3-7). When lowering the lift to the ground, the operator must keep the DOWN switch depressed two full seconds after the platform is on the ground. On releasing the DOWN switch the gate will then drop. Since receiving the first order of lifts, Metro has modified the safety gate to increase its angle.

There is also a system of interlocks with the main lift power switch. The lift cannot be turned on until the bus door is open. Turning on the lift power sets interlocks with the door, the accelerator, and the brake. Until the lift is stowed, the door cannot be closed, the brake cannot be released, and the accelerator will not work. Turning on the lift power automatically sets the brake if it was not already set.

There is no interlock to prevent stowing the lift with a passenger on it. However, such an action would have to be very deliberate on the part of the driver, as stowing the lift requires simultaneously depressing two switches, separated by a third switch between them, and keeping the switches depressed. Moreover, according to Metro's lift engineer, it is very unlikely that the stow mechanism would successfully operate with weight on the platform.

3.6 POLICIES AND PROCEDURES

3.6.1 When and Where the Lift Will be Operated

The lift is to be operated only on runs designated accessible on the time tables, and only at bus stops designated accessible. As noted before, 53 accessible coaches were scheduled for non-accessible service, due to general equipment shortage. In addition, accessible spares are sometimes used as spares for non-accessible service. Handicapped passengers can easily identify the accessible coaches by their general appearance and by the presence of the international accessibility decal on them, and the legend "wheelchair lift equipped" on the front of the buses (see Figure 3-11). Nevertheless, drivers are not supposed to board passengers with the lift except on designated accessible runs, although some handicapped people continue to request such service. Similarly, handicapped passengers occasionally want to use the lift at stops



FIGURE 3-11. FLYER COACH WITH ACCESSIBILITY MARKINGS

not considered accessible by Metro. While some drivers accede to such requests, others stick to the official policy. These points have been an occasional source of misunderstanding and complaints by handicapped passengers.

3.6.2 Boarding and Deboarding

Lift passengers are instructed to board and deboard after other passengers. The backwards boarding position is recommended but not required, to minimize maneuvering within the bus. Attendants may ride the lift with the handicapped passenger. Non-wheelchair users may use the lift if they cannot climb the bus steps. Foot prints painted on the lift show standing lift users where to stand to avoid bumping their heads on the door frame. Figure 3-12 is a sample of Metro's instructions to lift users.

the lift

makes Metro accessible

You Can Use The Lift

If you are physically unable to climb bus steps you may use the lift. (Example: those using wheelchairs, crutches or those who have a heart condition). Bring a friend if you need assistance in getting on or off the lift. Metro drivers will give you verbal instructions to use the equipment, but must remain in the driver's seat to operate lift controls.

To Catch The Bus

Look for the symbol (in the upper right hand corner of this bulletin) denoting lift-equipped buses. Wait near the front of the bus zone so the driver can see you.

Getting On

1. When the bus arrives, allow other passengers to get on or off, then tell the driver you want to use the lift. Wait five feet from the front door as the lift is lowered.

2. When the short ramp on the front of the lift drops down, you can board. Move on to the platform facing either direction, however, for ease in situating wheelchairs in tie-down area Metro recommends backing onto the lift to be in position to back into tiedowns. If you are accompanied by an attendant or friend, he or she may ride the lift with you.

3. *Wheelchair Passengers* — prevent your chair from rolling while riding the lift. The ramp will swing up to form a safety gate as the lift is raised.

Standing Passengers — stand on the footprints behind the white line, and hold handrails. The ramp will swing up to form a safety gate as the lift is raised.

4. When the lift stops at floor level, move onto the bus. Tell the driver where you wish to get off.

Standing Passengers — watch your head as you move through the doorway — there is only a five foot clearance.

Tying Down

Each bus has two wheelchair areas near the front. Two kinds of tiedowns are provided for any wheelchair model. Metro recommends that you also have a seat-belt on your chair.

If both tiedown areas are occupied by persons who must remain there, you may board the bus only if you can transfer to a bus seat and collapse your chair. You may not remain in a non-secured wheelchair while the bus is moving.

Tiedown instructions:

1. Back into the area and maneuver the rear wheel of your chair into claw clamp. The clamp will automatically close when the wheel hits the plate at the back of the clamp. (To unlock the clamp, push down on the knob by your rear wheel.)

2. The driver will help secure the red cargo strap to the other side of your chair.



Look for this symbol...

3. If your rear wheel will not fit into the claw clamp, both red cargo straps must be secured to your chair.
4. The seat belt provided is optional.

When the bus comes to your stop, the driver will release your chair from the tiedowns.

Getting Off

1. A block before your stop, signal the driver you wish to get off by pulling the cord.

2. Allow other passengers to get off first. When the lift is in position, move to the front of the bus.

3. Move onto the lift platform. *Wheelchair Passengers* — prevent your chair from rolling while riding the lift. *Standing Passengers* — move to the outer edge of the platform, standing on the footprints. Watch your head as you move through the doorway.

4. When the lift reaches the ground, the ramp will drop down. Move off of the platform.

Bus Fare

15¢ with Reduced Fare Permit

50¢ full-fare, one zone

75¢ full-fare, two zone

Route and Schedule Information:

Route and schedule information is updated regularly in "The Lift Bulletin" which is available in the Customer Assistance Office, 821 Second Avenue, Seattle, WA 98104. Metro bus timetables have symbols next to each trip that is equipped with a lift. If you need specific information on lift-equipped buses, call a Metro information operator at 447-4800 (24 hours a day).



(10/80)

FIGURE 3-12. METRO'S INSTRUCTIONS TO LIFT USERS

3.6.3 Driver Responsibilities

Driver responsibilities have been worked out in great detail, beginning during the planning phase and continuing up to the present time. The detailed responsibilities and procedures are spelled out in the training outline reproduced here as Appendix A. It is based on contributions from the accessibility planning staff, the driver training program, and the Driver Task Force on accessibility (see 3.1.4 above).

In the course of normal operations, drivers are not supposed to assist passengers in boarding or deboarding. Drivers are supposed to inform wheelchair users that the preferred boarding position is backwards, which minimizes the amount of maneuvering inside the bus. The backwards boarding position is not officially mandatory, since it is not possible for some people or in some situations. Nevertheless, some drivers appear to have tried to enforce a backwards boarding policy at all times.

Most passengers do require assistance getting into and out of the tie-down, and providing such assistance is a driver's responsibility. Many passengers also have difficulty maneuvering between the door and the wheelchair position, although drivers are not required to assist in this operation. Initially, the drivers were directed to require wheelchair passengers to wear the seat belt provided in the wheelchair position. This policy generated some complaints by passengers who considered it discriminatory, since non-wheelchair passengers are not required to wear a seat belt. As of March 1980, the policy was modified to allow wheelchair passengers to use their own seat belt instead of Metro's. As of June 1980, it was decided that people in wheelchairs who need seat belts already have them, so seat belt use was made optional. Both of these optional policies, backwards boarding and seat belt use, have been matters of continuing confusion.

Drivers were initially required to check the lift by "exercising" it prior to pulling out on a run. Due to lack of time and room at the maintenance bases, this responsibility was shifted to the mechanics. They are now supposed to exercise the lift as part of the daily fueling and washing process. Other driver responsibilities include:

1. Calling the coordinator when a lift passenger cannot be boarded, and informing the passenger what action (if any) will be taken.
2. Asking the passenger where he or she wishes to deboard, and stopping the bus at the correct position to operate the lift at that stop.

3. Asking non-disabled passengers occupying the fold-up seats to move to other seats so that the wheelchair can be secured.

If both wheelchair positions are occupied, another wheelchair passenger may be boarded if one of the wheelchair passengers is willing and able to transfer to a regular seat, and collapse and secure the chair. Drivers are not required to assist in this operation.

3.7 DRIVER TRAINING AND ATTITUDES

3.7.1 Training

Metro employs approximately 1,900 drivers, including about 700 part-time drivers and about 250 extra board drivers (all full time). Before operating accessible service an operator must qualify by completing Metro's lift training. All extra board drivers have been given the training, since they must be available to operate any assignment, including accessible ones. In addition about 200 regular drivers have completed the training. All new operators receive lift training. In addition, instructors are available at each operating base during sign-ups to provide review training if requested.

The training program was developed with some input from community agencies who deal with disabled citizens. Union personnel reviewed the training program, as well as the plans for accessible service. The 2-hour session is delivered to groups of one to four drivers. A lift-equipped coach serves as the classroom. A wheelchair is used as a training tool. All drivers are required to operate the lift and play the role of a wheelchair passenger by boarding, deboarding and riding in a wheelchair. There is a discussion period. Driver and passenger responsibilities are explained and handout materials are distributed. An outline of the training is reproduced in Appendix A.

After January 1981 a 33-minute videotape was added to the training. Metro's instruction department produced this videotape, which features handicapped people in different types of wheelchairs and explains how they wish to be treated, after the Human Rights Commission filed a complaint with Metro asking that handicapped persons be involved in the training process. The possibilities of using handicapped volunteers or a single paid handicapped trainer were considered but found to be infeasible or undesirable. However, the videotape has been approved by the commission as satisfying its concerns.

Most drivers appear to find the training adequate: 56% describe it as good and 20% as excellent. Detailed responses are shown in Table 3-3*.

*These figures are based on a mail-back survey distributed by Metro to all drivers on accessible runs in late October 1980. The questionnaire is reproduced in Appendix B.

TABLE 3-3. DRIVER OPINION OF LIFT OPERATION TRAINING

| <u>Opinion</u> | % of Regular Drivers (n=194) | % of Extra-Board Drivers (n=167) | % of All Drivers* (n=370) |
|----------------|---------------------------------------|---|---------------------------------|
| Excellent | 21% | 20% | 20% |
| Good | 61 | 49 | 56 |
| Fair | 17 | 28 | 21 |
| Poor | 1 | 3 | 2 |

* Includes part-time drivers

3.7.2 Attitudes

The drivers seem generally supportive of the service, although not without reservation and not without exception. Some things which stand out as receiving less than the highest marks in Table 3-4 include the safety of the lift for non-wheelchair passengers, the driver training, and the mechanical reliability of the lift, which scores rather poorly. Few drivers actually see significant lift use on their runs. On an open-ended comment question, tabulated in Table 3-5, the most frequent comments were supportive of the service. A significant minority had complaints, however, including a need for more recovery time.

TABLE 3-4. RESULTS OF DRIVER SURVEY

| | <u>Excellent</u> | <u>Good</u> | <u>Fair</u> | <u>Poor</u> | <u>(n)</u> |
|---|------------------|-------------|-------------|-------------|------------|
| Safety of lift for wheelchair users | 35% | 52 | 11 | 2 | 366 |
| Safety of lift for non-wheelchair handicapped | 20% | 45 | 22 | 12 | 352 |
| Lift Mechanical reliability | 3% | 31 | 43 | 23 | 370 |
| Ease of Operation by Driver | 40% | 43 | 12 | 4 | 367 |
| Lift Operation & Sensitivity Training | 21% | 56 | 21 | 2 | 374 |

| <u>How Often Do Wheelchair Users Need Assistance Tying Down?</u> | <u>% (n=371)</u> | <u>How Do Wheelchairs Fit Into the Wheel Locks?</u> | <u>% (n=369)</u> |
|--|------------------|---|------------------|
| Never | 2% | Most fit easily | 49% |
| 1/4 of the time | 14 | Many fit, but with difficulty | 47 |
| 1/2 of the time | 21 | Very few fit | 4 |
| 3/4 of the time | 29 | | |
| Always | 33 | | |

| <u>Average Use of the Lift</u> | <u>% (n=370)</u> | <u>Driver Task Force Beneficial?</u> | <u>% (n=328)</u> |
|--------------------------------|------------------|--------------------------------------|------------------|
| Less than 1 a week | 45% | Yes | 80% |
| Less than 1 a day | 26 | No | 20 |
| Once a day | 15 | | |
| Twice a day | 11 | | |
| 3 times a day | 3 | | |
| 4 or more times a day | 1 | | |

| <u>Behavior of non-disabled passengers</u> | <u>Never</u> | <u>Seldom</u> | <u>Often</u> | <u>Always</u> | <u>(n)</u> |
|--|--------------|---------------|--------------|---------------|------------|
| Complain about lift? | 54% | 39 | 4 | 2 | 347 |
| Move out of fold-up seats? | 5% | 10 | 34 | 51 | 349 |
| Help wheelchair passengers? | 28% | 41 | 25 | 5 | 348 |
| Move out of the way? | 4% | 10 | 40 | 46 | 342 |

TABLE 3-5. DRIVER COMMENTS

| <u>Comment</u> | <u>% of Drivers (n=381)</u> |
|--------------------------------|-----------------------------|
| General positive remarks | 24% |
| Need more recovery time | 11 |
| Benefit to user | 8 |
| Maintenance needed | 5 |
| Improve equipment | 6 |
| Prefer separate service | 6 |
| Waste of money | 3 |
| Unreliable | 3 |
| Little use of lift | 4 |
| Other (max. of 2% per comment) | 15% |

3.8 MARKETING AND OUTREACH

3.8.1 Public Information

Metro has not used advertising, paid or not, to promote the accessible service. The decision not to advertise was based on a desire to avoid "overselling" the service while it was being phased in. In line with Metro's philosophy that lift service is an integral part of regular service, accessible information is incorporated in every route information piece available to non-disabled riders. The service has received a lot of news coverage. Other channels through which the public learns about accessible service include:

1. International accessibility symbols and the words "wheelchair lift-equipped" on the lift-equipped buses and accessibility symbols on bus stop signs where the lift can be used;
2. Timetables for accessible routes have an accessibility symbol on the cover, and indicate accessible trips by an "L" on the schedule (see Figure 3-13).

Route

17

Serving

Loyal Heights, Sunset Hill,
Seattle Pacific University,
Downtown Seattle

Route Map & Timetable

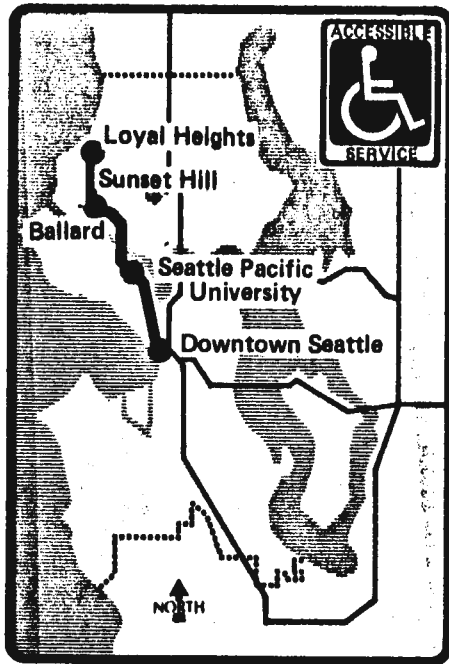

Effective May 24 thru Sept. 12, 1980

WEEKDAY READ ACROSS →

| Sunset Hill | Ballard | Downtown Seattle | | |
|----------------------------|-------------------------------|---------------------------|--------------------------|-------------------|
| Loyal Ave NW & View Ave NW | Ballard Ave NW & NW Market St | 15th Ave NW & NW Laary Wy | Dexter Ave N & Fulton St | 1st Ave & Pike St |
| 5:16 | 5:26 | 5:29 | 5:38 | 5:50t |
| L 5:47 | 5:58 | 8:01 | 8:09 | 8:25tt |
| L 8:18 | 8:29 | 8:32 | 8:40 | 8:56tt |
| 8:33 | 8:45 | 8:48 | 8:57 | 7:15D |
| L 8:49 | 7:01 | 7:04 | 7:13 | 7:31tt |
| — | — | 7:25 | 7:34 | 7:52 |
| 7:14 | 7:28 | 7:29 | 7:38 | 7:58t |
| L 7:26 | 7:38 | 7:41 | 7:50 | 8:08 |
| 7:38 | 7:50 | 7:53 | 8:02 | 8:20 |
| 7:50 | 8:02 | 8:05 | 8:14 | 8:32tt |
| L 8:03 | 8:15 | 8:18 | 8:27 | 8:45 |
| L 8:28 | 8:40 | 8:43 | 8:51 | 9:07t |
| L 8:58 | 9:10 | 9:13 | 9:21 | 9:37tt |
| 9:28 | 9:40 | 9:43 | 9:51 | 10:07t |
| 9:58 | 10:10 | 10:13 | 10:21 | 10:37tt |
| L 10:28 | 10:40 | 10:43 | 10:51 | 11:07t |
| L 10:58 | 11:10 | 11:13 | 11:21 | 11:37tt |
| L 11:28 | 11:40 | 11:43 | 11:51 | 12:07t |
| 11:58 | 12:10 | 12:13 | 12:21 | 12:37tt |
| 12:29 | 12:40 | 12:43 | 12:51 | 1:07t |
| 12:59 | 1:10 | 1:13 | 1:21 | 1:37tt |
| L 1:29 | 1:40 | 1:43 | 1:51 | 2:07t |
| L 1:59 | 2:10 | 2:13 | 2:21 | 2:37tt |
| 2:38 | 2:49 | 2:52 | 3:00 | 3:17t |
| 3:01 | 3:11 | 3:14 | 3:22 | 3:40tt |
| L 3:28 | 3:38 | 3:39 | 3:47 | 4:05Ctt |
| L 3:37 | 3:47 | 3:50 | 3:58 | 4:16Ct |
| 4:11 | 4:21 | 4:24 | 4:32 | 4:50Ct |
| L 4:41 | 4:51 | 4:54 | 5:02 | 5:20Ct |
| 5:01 | 5:11 | 5:14 | 5:22 | 5:40t |
| 5:11 | 5:21 | 5:24 | 5:32 | 5:50tt |
| 5:31 | 5:41 | 5:44 | 5:52 | 8:10tt |
| 5:57 | 8:08 | 8:09 | 8:18 | 8:30t |
| L 8:22 | 8:31 | 8:34 | 8:41 | 8:55tt |
| L 8:52 | 7:01 | 7:04 | 7:11 | 7:25t |
| L 7:22 | 7:31 | 7:34 | 7:41 | 7:55tt |
| 7:52 | 8:01 | 8:04 | 8:11 | 8:25t |
| L 8:22 | 8:31 | 8:34 | 8:41 | 8:55tt |
| 8:52 | 9:01 | 9:04 | 9:11 | 9:25t |
| 9:22 | 9:31 | 9:34 | 9:41 | 9:55tt |
| 9:52 | 10:01 | 10:04 | 10:11 | 10:25tt |
| L 10:22 | 10:31 | 10:34 | 10:41 | 10:55tt |
| L 10:52 | 11:01 | 11:04 | 11:11 | 11:25tt |
| L 11:22 | 11:31 | 11:34 | 11:41 | 11:55tt |
| 11:52 | 12:01 | 12:04 | 12:11 | 12:25 |
| 12:52 | 1:01 | 1:04 | 1:11 | 1:24 |

AM — Lighter Type
PM — Darker Type

WEEKDAY READ ACROSS →

| Downtown Seattle | | | Ballard | Sunset Hill |
|------------------------|--------------------|--------------------------|-------------------------------|----------------------------|
| 1st Ave S & Jackson St | 4th Ave & Union St | Dexter Ave N & Fulton St | Ballard Ave NW & NW Market St | Loyal Ave NW & View Ave NW |
| — | — | 4:58 | 5:05 | 5:14 |
| L — | — | 5:27 | 5:36 | 5:45 |
| 5:34 | 5:45B | 5:57 | 6:06 | 6:15 |
| 6:04 | 6:15B | 6:27 | 6:36 | 6:45 |
| L 6:37 | 6:45 | 6:57 | 7:06 | 7:15 |
| 7:01 | 7:10 | 7:23 | 7:32 | 7:43 |
| L 7:12 | 7:21 | 7:34 | 7:43 | 7:52 |
| L 7:41 | 7:50 | 8:03 | 8:12 | 8:21 |
| 8:13 | 8:22 | 8:35 | 8:44 | 8:53 |
| 8:43 | 8:52 | 9:05 | 9:14 | 9:23 |
| L 9:12 | 9:21 | 9:35 | 9:45 | 9:54 |
| L 9:42 | 9:51 | 10:05 | 10:15 | 10:24 |
| L 10:12 | 10:21 | 10:35 | 10:45 | 10:54 |
| 10:42 | 10:51 | 11:05 | 11:15 | 11:24 |
| 11:12 | 11:21 | 11:35 | 11:45 | 11:54 |
| 11:42 | 11:51 | 12:05 | 12:15 | 12:24 |
| L 12:12 | 12:21 | 12:38 | 12:47 | 12:56 |
| L 12:42 | 12:51 | 1:08 | 1:17 | 1:26 |
| 1:12 | 1:21 | 1:38 | 1:47 | 1:56 |
| 1:42 | 1:51 | 2:08 | 2:17 | 2:26 |
| L 2:12 | 2:21 | 2:38 | 2:47 | 2:57 |
| L 2:42 | 2:51 | 3:08 | 3:17 | 3:27 |
| L 3:12 | 3:21 | 3:38 | 3:47 | 3:57 |
| 3:41 | 3:51 | 4:07 | 4:18 | 4:29 |
| 4:01 | 4:11 | 4:27 | 4:38 | 4:49 |
| 4:05 | 4:15 | 4:31 | 4:42 | 4:53 |
| 4:17 | 4:27 | 4:44 | 4:55 | 5:07 |
| 4:30 | 4:40 | 4:57 | 5:08 | 5:20 |
| 4:43 | 4:53 | 5:10 | 5:21 | 5:33 |
| 4:55 | 5:05 | 5:22 | 5:33 | 5:45 |
| 5:00 | 5:10 | 5:27 | 5:38 | 5:50 |
| 5:11 | 5:21 | 5:38 | 5:49 | 6:01 |
| L 5:28 | 5:38 | 5:53 | 6:04 | 6:16 |
| L 5:48 | 5:58 | 6:13 | 6:24 | 6:34 |
| 6:08 | 6:14 | 6:31 | 6:42 | 6:52 |
| L 6:38 | 6:44 | 6:58 | 7:05 | 7:14 |
| 7:04 | 7:15B | 7:27 | 7:36 | 7:45 |
| L 7:34 | 7:45B | 7:57 | 8:06 | 8:16 |
| 8:04 | 8:15B | 8:27 | 8:36 | 8:45 |
| 8:34 | 8:45B | 8:57 | 9:06 | 9:15 |
| 9:04 | 9:16B | 9:27 | 9:36 | 9:46 |
| L 9:34 | 9:45B | 9:57 | 10:06 | 10:16 |
| L 10:04 | 10:15B | 10:27 | 10:36 | 10:46 |
| L 10:34 | 10:45B | 10:57 | 11:06 | 11:16 |
| 11:04 | 11:15B | 11:27 | 11:36 | 11:45 |
| 12:04 | 12:15B | 12:27 | 12:36 | 12:45 |
| 1:04 | 1:15B | 1:27 | 1:36 | 1:45 |

FIGURE 3-13. TIMETABLE FOR ACCESSIBLE SERVICE

3. Posters inside the buses provide courtesy tips concerning accessible service.

Metro's 24-hour telephone information service answers questions about accessible service. In addition to route and schedule information, telephone operators identify which stops are accessible, and the nearest accessible stops to a caller's origin and destination. Figure 3-14 is a sample of the list of accessible stops used by the information operators. It, and the instructions to lift users shown in Figure 3-12, are sent to people who call for information and people on Metro's accessibility mailing list.

3.8.2 Outreach

Lift-equipped buses are taken to schools, group residences, agencies and other locations to demonstrate the operation of the lift, and give potential riders a chance to practice using the lift. Between September 1979 and December 1980, 24 such demonstrations were given.

As individuals and organizations interested in accessible service have been identified during the planning and implementation of the service, they have been added to a mailing list. The roughly 150 individuals and organizations on the list receive a bulletin which explains the lift service, notes changes, and identifies all accessible routes and bus stops. Appendix C contains the October 1980 bulletin. A new bulletin is sent at least once every schedule change (three times a year) and whenever significant modifications to accessible service have been made.

ACCESSIBLE ZONES ON ROUTE 7

NORTHBOUND 62-PRENTICE TO UNIV. DIST.

| | | |
|----------------|---------------------|-----|
| 62 Ave. S. | -Prentice | Yes |
| S. Prentice | -64 Ave. S. | Yes |
| 64 Ave. S. | -S. Ryan | No |
| " | -S. Cooper | No |
| " | -Waters Ave. S. | No |
| Waters Ave.S. | -S. Norfolk | No |
| " | -S. Pilgrim | Yes |
| " | -S. Roxbury | Yes |
| " | -S. Carver | Yes |
| 57 Ave. S. | -Waters Ave. S. | Yes |
| Rainier Ave.S. | -Seward Pk. Ave. | Yes |
| Rainier Ave.S. | -54 Ave. S. | Yes |
| " | -52 Ave. S. | Yes |
| " | -S. Fisher Pl. | Yes |
| " | -S. Henderson St. | Yes |
| " | -S. Rose St. | Yes |
| S. Rose St. | -Rainier Ave. S. | Yes |
| Rainier Ave.S. | -S. Kenyon | Yes |
| " | -S. Holden | Yes |
| " | -S. Fontanelle | Yes |
| " | -S. Othello | Yes |
| " | -S. Myrtle | Yes |
| " | -S. Willow | Yes |
| " | -S. Holly | Yes |
| " | -S. Morgan | Yes |
| 46 Ave. S. | -S. Graham | No |
| Rainier Ave.S. | -S. Graham | Yes |
| " | -S. Spencer | Yes |
| " | -S. Juneau | Yes |
| " | -S. Orcas | Yes |
| " | -S. Lucille | Yes |
| " | -S. Brandon | Yes |
| " | -39 Ave. S. | Yes |
| " | -S. Hudson | Yes |
| " | -S. Ferdinand | Yes |
| " | -S. Edmunds | Yes |
| " | -S. Alaska | Yes |
| " | -S. Oregon | Yes |
| " | -S. Genesee | Yes |
| " | -S. Dakota | Yes |
| " | -S. Andover | Yes |
| " | -S. Charlestown | Yes |
| " | -S. Court | Yes |
| " | -S. Walden | Yes |
| " | -S. Byron | Yes |
| " | -S. Mt. Baker Blvd. | Yes |
| " | -S. McClellan | Yes |
| " | -25 Ave. S. | Yes |

| | | |
|-------------------------------|----------------|-----|
| Rainier Ave.S. | -S. Walker | Yes |
| " | -S. Plum | Yes |
| " | -S. Grand | Yes |
| " | -21 Ave. S. | Yes |
| " | -S. Atlantic | Yes |
| " | -S. Bush | Yes |
| " | -S. Charles | No |
| " | -S. Dearborn | Yes |
| " | -S. Weller | Yes |
| S.Jackson St.-Boren | Av.S.(14 S.) | Yes |
| " | -12 Ave. S. | Yes |
| " | -10 Ave. S. | Yes |
| " | -8 Ave. S. | Yes |
| " | -Maynard Av.S. | Yes |
| " | -5 Ave. S. | Yes |
| Downtown Zones Are Accessible | | |
| Pike St | 9th Ave | yes |
| E. Pike St. | -Terry | Yes |
| E. Pike St. | -Minor | Yes |
| E. Pine St. | -Summit | Yes |
| E. Pine St. | -Harvard | Yes |
| Broadway | -E. Olive Wy. | Yes |
| " | -E. Howell | Yes |
| " | -E. John | Yes |
| " | -E. Harrison | Yes |
| " | -E. Mercer | Yes |
| E. Roy St. | -10 Ave. E. | Yes |
| 10 Ave. E. | -E. Aloha | Yes |
| " | -E. Prospect | Yes |
| " | -E. Highland | Yes |
| " | -E. Galer | Yes |
| " | -E. Blaine | No |
| " | -E. Howe | Yes |
| " | -E. Boston | Yes |
| " | -E. Miller | Yes |
| " | -E. Roanoke | Yes |
| E. Roanoke | -Broadway E. | Yes |
| Harvard Ave.E. | -E. Edgar | Yes |
| " | -E. Hamlin | Yes |
| " | -E. Shelby | Yes |
| " | -E. Allison | Yes |
| " | -E. Martin | Yes |
| N.E. Camous Pk.Wy. | -11 Ave. NE. | Yes |
| N.E. Camous Pk.Wy. | -Brooklyn | Yes |
| 15 Ave. NE. | -N.E. 41 | Yes |
| " | -N.E. 42 | Yes |
| " | -N.E. 43 | Yes |
| N.E. 45 | -Univ. Wy. NE. | Yes |
| N.E. 45 | -12 Ave. NE. | Yes |
| 11 Ave. N.E. | -NE. 45 | Yes |
| 12 Ave. N.E. | -NE. 47 | Yes |

(Terminal)

FIGURE 3-14. LIST OF ACCESSIBLE STOPS

37/38

2/2/80
revised 5/24/80
10/27/80

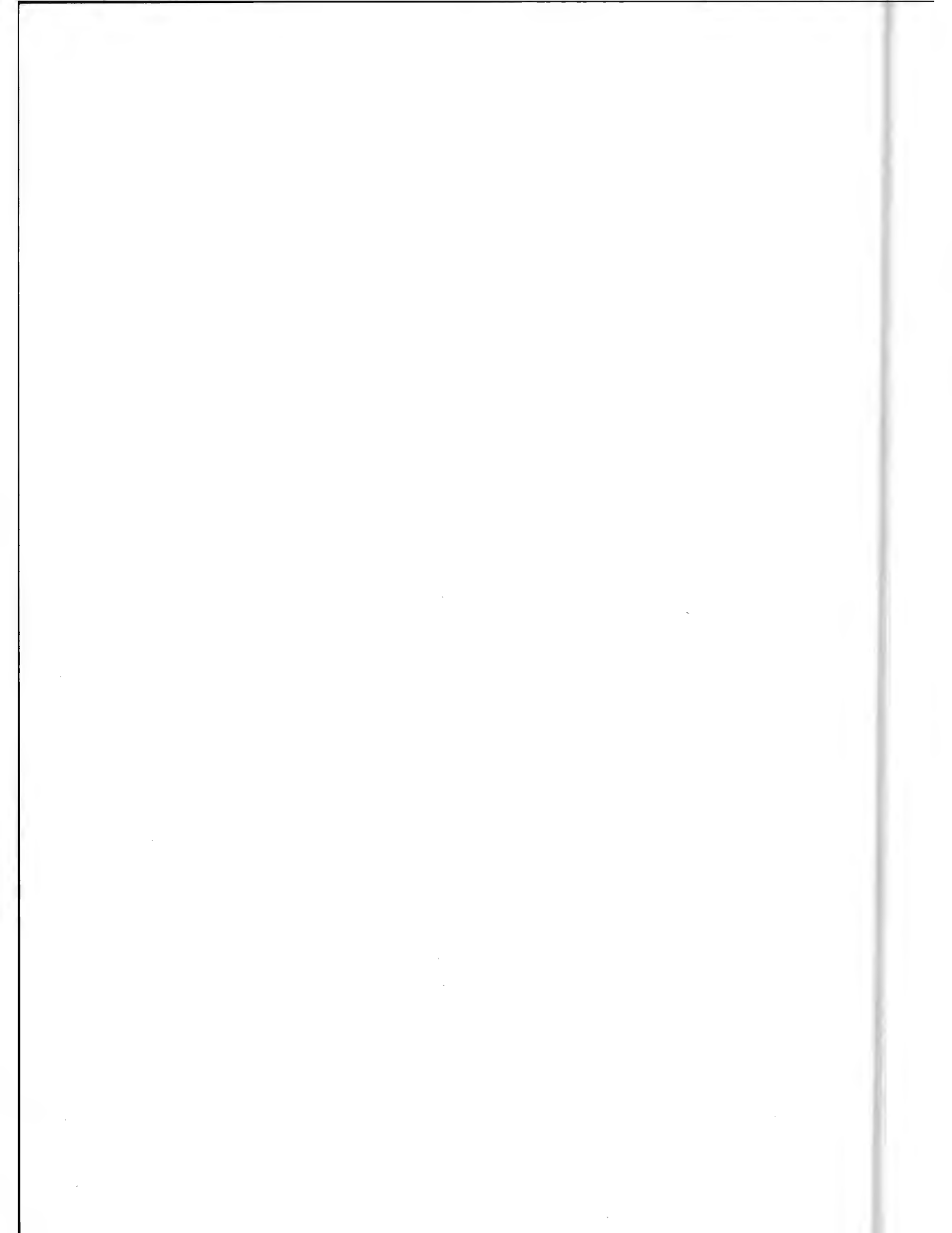

4. RIDERSHIP

4.1 RIDERSHIP LEVELS

4.1.1 Boarding Counts

Ridership levels for the Seattle accessible bus service are much higher than those achieved in most other U.S. cities. Table 4-1 shows the results of nine lift-use counts taken by Metro.* The amount of service offered increased only slightly over most of the period studied. Once the 23-route level of service was reached, ridership climbed to a plateau where it remained until October 1980. The dip in October may indicate a seasonal decline. The last three lines of Table 4-1 show increased ridership with the addition of accessible service on 16 more routes on January 31, 1981. This information is presented for the sake of completeness, although no analysis on it has been undertaken.

TABLE 4-1. LIFT USE COUNTS

| Dates | Days Counted | Average Boardings Per Day | | | Accessible Routes |
|--------------------|-----------------|---------------------------|---------|-------|----------------------|
| | | Weekday | Weekend | Daily | |
| Feb 23-Mar 2, 1980 | 9 | 39 | 37 | 38 | 23 |
| Mar 29-Apr 6 | 9 | 73 | 25 | 59 | 23 |
| May 17-23 | 4 | 64 | 46 | 59 | 23 |
| Jul 19-24 | 4 | 74 | 53 | 68 | 24 |
| Aug 16-21 | 4 | 71 | 41 | 62 | 24 |
| Oct 14-19 | 4 | 54 | 46 | 52 | 26 |
| Feb 28-Mar 5, 1981 | 4 | 94 | 87 | 92 | 42 |
| Apr 25-30 | 5 | 111 | 80 | 102 | 42 |
| Jul 11-16 | 4 | 158 | 115 | 145 | 45 |

*Metro does not perform regular daily passenger counts for total ridership or lift use. Lift use is counted on an irregular basis. On the days chosen for the counts, all drivers on scheduled accessible runs receive a card as part of their "paddle" on which they are asked to record total lift use, passengers passed up due to lift malfunctions, passengers passed up due to overloads, and the number of wheelchair and standing lift users. The cards are returned by interdepartmental mail. Generally, more than 90% of drivers on scheduled accessible runs return their cards. It is assumed that most of those not returning a card had no lift users to report. Appendix F shows a sample of the card.

There have probably been a few more boarding attempts than are shown here. As shown in Chapter 6, one or two passengers a day make unsuccessful boarding attempts, either due to lift equipment problems or overload conditions. However, as shown in Table 6-4, following an unsuccessful boarding attempt, most lift users wait for the next bus. Then they would usually get counted as a successful boarding.

4.1.2 Comparison with Other Systems

This section compares lift use in Seattle with that observed on accessible services in other transit systems. Since transit systems and the areas they serve differ in many ways, it is important to present ridership in a form which can be meaningfully compared from one location to another. In this analysis, lift use as a percentage of total ridership on accessible routes ("proportional lift use") is proposed as a measure which should be reasonably comparable from one city to another, assuming equally reliable and well-promoted service. This measure is based on the notion that the contribution of wheelchair users (92% of lift users in Seattle) to ridership on accessible routes should be related to the proportion of the total population which they represent. Comparing the percentage of lift users among transit riders should account for many of the obvious major sources of variation in simple lift use counts, such as total population in the area served, the amount of service offered on accessible routes, and the overall rate of transit usage or mode split in different cities. There are still reasons why the proposed measure will differ from city to city, and examining the likely reasons for observed differences should yield some insights. Examples of factors which would affect the proportional lift use include: the incidence of wheelchair users in the population; differences in wheelchair users' origins and destinations from those of the general population; service reliability and marketing; and the natural environment (weather and terrain). These are discussed at greater length in Section 4.5.

In Seattle, for 23 routes, on which 43% of trips were accessible, wheelchair boardings equaled 0.07% of revenue ridership.* Table 4-2 shows similar figures for other transit systems which offer accessible service. Compared to the other systems, total daily lift use in Seattle is very high. However, in terms of proportional lift use, Champaign-Urbana has an even higher level of lift use than Seattle. The Champaign figures are high despite the fact that they include the winter months, when conditions would discourage wheelchair use. However, Champaign has flat terrain, and may have a higher-than-average proportion of handicapped in its population due to the presence of special facilities and programs at the University of Illinois. AC Transit's proportional lift use may be approximately equal to Seattle's, and even the total use count may be higher than Seattle's was in 1980

*Revenue ridership is based on Metro's estimate of total 1980 ridership of 66,071,730, times the percentage of revenue collected on accessible routes on one day in July 1980 (35.1%), divided by 300.

TABLE 4-2. COMPARISON OF PROPORTIONAL LIFT USAGE

| <u>System</u> | <u>Percent Accessible</u> | <u>Total Daily Passengers on Accessible Routes</u> | <u>Daily Lift Boardings</u> | <u>Lift Use as % of Ridership on Accessible Routes</u> |
|------------------------------|---------------------------|--|-----------------------------|--|
| AC Transit (34 routes) | n/a | 129,600 | 94 (July 15, 1981) | .07% |
| Champaign (3 routes) | 90% | 3,000 | 2.3 (July 1980-May 1981) | .08% |
| Palm Beach | 100% | 10,900 | 4.0 (Oct 1980-Mar 1981) | .04% |
| Hartford | 84% | 45,100 | 5.2 (Sept 1980) | .01% |
| New Haven | 86% | 25,500 | 5.9 (Sept 1980) | .02% |
| Stamford | 90% | 4,400 | 1.2 (Sept 1980) | .03% |
| Seattle (23 routes) | 43%* | 77,300 | 56 (Feb-Oct 1980) | .07% |
| Orange County (13 routes) | 90% | 30,500 | 10.0 (July 1980-Jan 1981) | .03% |

*Percent of peak trips

Sources: AC Transit--Personal communication with Carol Weinstein, AC Transit
 Champaign--Champaign-Urbana Transit District, through on-going C&A evaluation of SMD project
 Hartford, New Haven & Stamford--Charles River Assocs., "Fixed Route Accessible Bus Service in Connecticut: A Case Study", UMTA/TSC Evaluation Series, March 1981
 Orange County--Personal communication with Linda Roxburgh Creed, Orange County Transit District
 Palm Beach--Personal communication with Larry Englisher, Multi-systems, Inc.

(although not higher than Seattle's 1981 lift use). Possible factors at work for AC Transit might include good weather, mostly flat terrain, and a very active handicapped population. In any event, it is clear that the Seattle system is one of the most successful so far implemented. Section 4.5 provides a more detailed discussion of this matter.

4.1.3 Ridership by Route

There is considerable variation in lift use levels among the accessible routes. Because many buses serve more than one route, ridership can be estimated only for route combinations. Table 4-3 shows average weekday lift use for 13 combinations which include lift-equipped service. Several routes account for most of the reported lift use. Four of the five highest-ridership combinations serve accessible housing projects, a cerebral palsy residential center, or a cerebral palsy training center. However, it is known from a survey of lift users that only 30% of trips are made by residents of special housing for the handicapped. Therefore it is not necessarily the case that the high ridership on these routes is solely due to serving the special locations mentioned.

Another hypothesis is that handicapped transit use should be highest on the routes with highest general ridership. A plot of lift use against general ridership, shown in Figure 4-1, appears to show a relationship. However, if the point representing the highest ridership route (route 7) is removed from consideration, the apparent relationship disappears. With route 7 removed from the analysis, a regression of lift use on ridership explains only 0.7% of the observed variation in lift use among routes. The lack of any clear explanation for which routes are most heavily used may stem from the very small number of individuals who account for most lift use.

4.1.4 The Effect of Weather

Lift use seems to vary with weather. Unfortunately the lift-use counts do not provide enough data for firm conclusions on this point. In the period March through August, ridership on 10 weekdays with generally good weather averaged 74 boardings; only one weekday with bad weather (i.e., rainy or stormy) was counted, and it had 39 boardings. Four weekend days with generally good weather averaged 64 boardings, while five weekend days with bad weather averaged 33 boardings. Although statistically

*Ridership by route combination was estimated from the percentage of total revenue collected on each accessible route combination on the second Wednesday of July 1980, and a preliminary Metro staff estimate of system-wide average daily revenue ridership of 228,000.

TABLE 4-3. LIFT USE BY ROUTE

| <u>Routes</u> | <u>Average week-day lift use (18 weekdays)</u> | <u>Percent of daily lift use</u> | <u>Cumulative percent of daily lift use</u> |
|---------------|--|----------------------------------|---|
| 7 | 16.4 | 28 | 28 |
| 6/16 | 12.1 | 20 | 48 |
| 317 | 6.6 | 11 | 59 |
| 5/55 | 5.4 | 9 | 68 |
| 22/305 | 5.3 | 9 | 77 |
| 18 | 3.9 | 7 | 84 |
| 72 | 3.7 | 6 | 90 |
| 15 | 1.5 | 3 | 93 |
| 19/136 | 1.4 | 2 | 95 |
| 17/130/132 | 1.1 | 2 | 97 |
| 150 | 0.8 | 1 | 98 |
| 30 | 0.7 | 1 | 99 |
| 107/253 | 0.6 | 1 | 100 |
| TOTAL | 59.5 | 100% | |

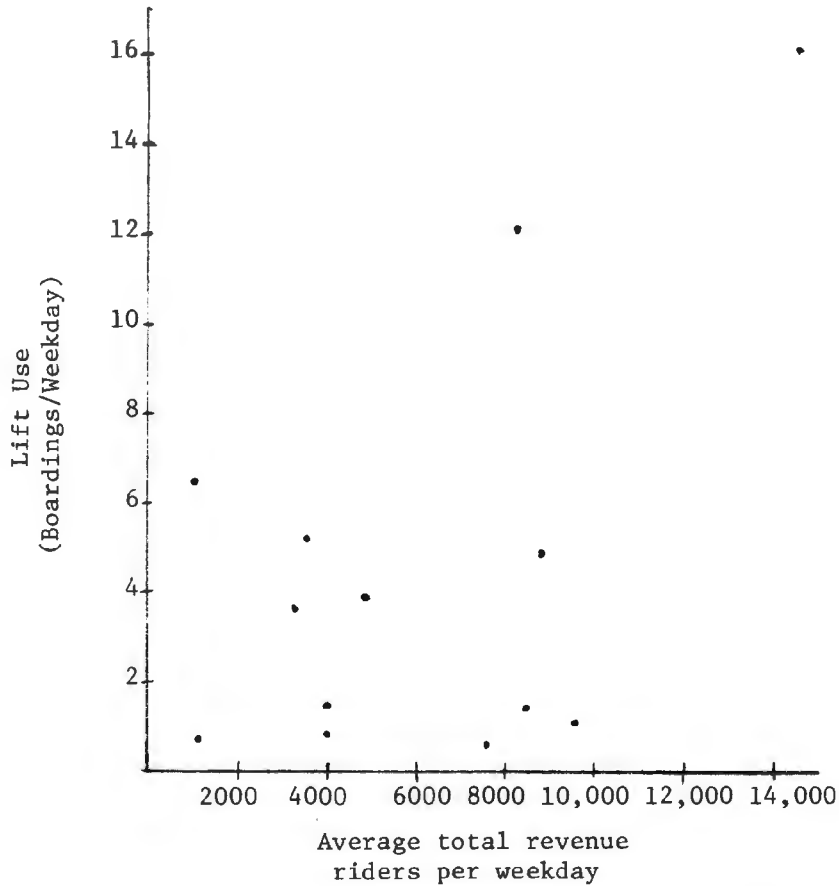

FIGURE 4-1. PLOT OF LIFT USE AND TOTAL REVENUE RIDERS

inconclusive, due to the small number of observations, these results agree with common sense, and also with reported behavior by the lift users. Of the 73 lift users interviewed, 15 or 21% said they do not ride the bus on rainy days. Instead, they either drive (7%), get a ride (4%), take a taxi or van service (3%), or don't travel at all (7%). Presumably many who do ride on rainy days do so less often.

Lift users seem much like other people in that they prefer not to or are less able to go distances outside in the rain. Whereas 59% of lift users said they can wheel or walk 10 blocks or more in good weather, only 25% said they could do this in bad weather. The percentage able to go three blocks or less increases from 22% to 39% as the weather turns bad.

4.2 RIDERSHIP CHARACTERISTICS

This section reports results of Metro's fall 1980 lift-user survey.

4.2.1 Description of the Lift-User Survey

The lift-user survey was conducted in two parts. First, as part of the four-day August lift-user count, drivers on accessible assignments were supplied with mail-back, self-administered survey cards, which they were asked to give to all lift users on the days of the counts. The card, which is reproduced in Appendix D, asked for basic information about the users and their trips, and a phone number at which to contact them for a longer interview. Forty-nine cards were returned, of which 22 were from lift-users and included a correct telephone number. These numbers were combined with 95 phone numbers from Metro's accessibility mailing list. During late October and early November interviewers called numbers from the combined list and administered the telephone survey reproduced in Appendix D. In all, 73 completed interviews were obtained.

The lift-user survey was not a random-sample survey, but rather a survey of all lift users who could be located and interviewed. Therefore one cannot be sure that the characteristics of the sample fairly represent those of the complete lift-using population. Nevertheless, several features of the sample make it plausible that the sample characteristics approximate those of at least the more active users.

First, there is the total sample size of 73. Average daily lift use at the time of the survey was only 52 boardings, or probably less than 30 passengers. Since many riders make regular trips (59% of those surveyed make three or more one-way

trips per week), we may conclude that the sample includes a very substantial fraction, perhaps a majority, of all lift users.

A second result supports this argument further. Table 4-4 shows respondents' reported trip frequencies, in one-way trips per week plus transfers. The total reported trip making implies an average of 100 boardings per day. Even assuming that respondents were reporting use based on the more active months just preceding the survey, the reported boardings still exceed actual lift use counts by 61% (daily boardings for April-August averaged 62). Two conclusions follow: respondents have over reported their use of lift buses; and, even allowing for substantial over reporting, the sample probably accounts for more than half of all lift use.*

4.2.2 Travel Characteristics

Tables 4-4 through 4-8 report various travel characteristics from the lift-user survey. The results show that most users make several trips per week. Although more users make trips for shopping, recreation and personal business than other purposes, many users make regular work trips, many involving transfers. As a result work trips account for 25% of reported trips, followed by recreational trips (22%), shopping trips (19%) and personal business trips (17%). These percentages are dominated by the trip purposes of the most frequent users. Among those who reported fewer than five trips per week ("non-frequent users" in Table 4-7), most trips are for shopping (36%), recreation or visits (27%) and personal business (19%). Lift users make considerable use of transfers; 31% of reported trips require one or more transfers. In all, 80% of users come two or more blocks to the bus stop, mostly by wheelchair. A slight majority of both frequent and non-frequent users come three or more blocks. Most users travel without an attendant (67%), and the great majority of trips are made by users who travel without an attendant (83%). Roughly half of users (45%) are also registered for Metro's taxi scrip program; more frequent users than non-frequent users reported being registered for the scrip program, although the sample size is too small to make the difference statistically significant. Frequent users also appear to make more use of taxis and rides from friends or relatives, and to have less ability to use or access to a car for driving themselves. This is consistent with the results which show that getting rides and taking taxis are the most frequent source for bus trips shifted from other modes.

4.2.3 Personal Characteristics

The most notable characteristics shown in Table 4-9 are the high percentage of users with electric wheelchairs, and the relatively young age profile of users. In age profile the lift users are more similar to the general transit-riding public than to the general handicapped population. Regarding the use

*It is also possible that Metro's counts understate lift use somewhat, since roughly 10% of drivers do not return the cards used for the counts. The amount of such undercounting is unlikely to account for all or even most of the difference between the counts and the survey results.

TABLE 4-4. TOTAL BUS TRIPS BY PURPOSE

| <u>Purpose</u> | <u>Reported total trips/week</u> | <u>Reported transfers/week</u> | <u>Reported boardings/week</u> | <u>Percent of trips</u> | <u>Percent of boardings</u> |
|-------------------|----------------------------------|--------------------------------|--------------------------------|-------------------------|-----------------------------|
| Work | 125 | 90 | 215 | 25% | 31% |
| Shop | 96 | 24 | 120 | 19 | 17 |
| School | 34 | 0 | 34 | 7 | 5 |
| Recreation | 111 | 46 | 157 | 22 | 22 |
| Personal Business | 83 | 23 | 106 | 17 | 15 |
| Medical | 31 | 19 | 50 | 6 | 7 |
| Other | 20 | 0 | 20 | 4 | 3 |
| TOTAL | 500 | 202 | 702 | | |

TABLE 4-5. TRANSFERS BY PURPOSE

| <u>Purpose</u> | <u>Percent of trips made using:</u> | | | <u>Average Transfers/Trip</u> |
|-------------------|-------------------------------------|-------------------|--------------------|-------------------------------|
| | <u>No Transfers</u> | <u>1 Transfer</u> | <u>2 Transfers</u> | |
| Work | 50 | 27 | 22 | .7 |
| Shop | 74 | 26 | - | .3 |
| School | 100 | - | - | - |
| Recreation | 65 | 29 | 6 | .4 |
| Personal Business | 81 | 11 | 8 | .3 |
| Medical | 49 | 45 | 6 | .6 |
| Other | 100 | - | - | - |
| TOTAL | 68 | 23% | 9% | .40 |

TABLE 4-6. LIFT USER TRAVEL CHARACTERISTICS

| <u>One-way trips per week</u> | <u>Percent of users (n=73)</u> |
|-------------------------------|------------------------------------|
| Fewer than 1 | 17% |
| 1-2 | 19 |
| 3-4 | 18 |
| 5-6 | 8 |
| 7-8 | 8 |
| 9-10 | 7 |
| More than 10 | 23 |

| <u>How get to bus stop</u> | <u>Percent of users (n=71)</u> |
|--------------------------------|------------------------------------|
| Wheel | 86% |
| Drive | 10 |
| Walk | 3 |
| Get ride | 1 |

| <u>How long used buses</u> | <u>Percent of users (n=71)</u> |
|----------------------------|------------------------------------|
| 1-3 months (Aug-Oct 1980) | 11% |
| 4-6 months (May-Jul) | 25 |
| 7-9 months (Feb-Mar) | 15 |
| 10-12 months (Nov-Jan) | 27 |
| 14 months (Sept 1979) | 22 |

| <u>Ever transfer</u> | <u>Percent of users (n=72)</u> |
|----------------------|------------------------------------|
| Yes | 67% |
| No | 33 |

TABLE 4-7. TRAVEL CHARACTERISTICS BY FREQUENCY OF USE

| Trip Purpose | Percent of users*(n=72) | Percent of trips (500 trips/wk) | Percent of trips by frequent users** (422 trips/wk) | Percent of trips by non-frequent*** users (77 trips/wk) |
|----------------------|-------------------------|---------------------------------|---|---|
| Work | 27% | 25% | 28% | 10% |
| Shop | 58 | 19 | 16 | 36 |
| School | 11 | 7 | 7 | 3 |
| Recreation/ visit | 58 | 22 | 21 | 27 |
| Personal business | 38 | 17 | 16 | 19 |
| Medical | 19 | 6 | 7 | 5 |
| Other | 11 | 4 | 5 | - |

| Distance from home to accessible stop | Percent of users(n=72) | Percent of frequent users** (n=33) | Percent of non-frequent users*** (n=39) | Percent of trips (498 trips/week) |
|---------------------------------------|------------------------|------------------------------------|---|-----------------------------------|
| Less than 1 block | 7% | 3% | 10% | 3% |
| About 1 block | 13 | 18 | 8 | 17 |
| About 2 blocks | 29 | 27 | 31 | 30 |
| 3 or more blocks | 51 | 52 | 51 | 50 |

| Travel with attendant | Percent of users(n=72) | Percent of frequent users (n=32) | Percent of non-frequent users (n=40) | Percent of trips (482 trips/week) |
|-----------------------|------------------------|----------------------------------|--------------------------------------|-----------------------------------|
| Yes | 26% | 13% | 38% | 12% |
| Sometimes | 7 | 3 | 10 | 5 |
| No | 67 | 84 | 53 | 83 |

*Responses add to more than 100% due to multiple responses.

**Those making five or more bus trips per week.

***Those making fewer than five bus trips per week.

TABLE 4-8. USE AND AVAILABILITY OF OTHER MODES

| Mode | Percent using other mode | | | Percent who have switched some trips to bus |
|-------------|--------------------------|---------------------------|--------------------------------|---|
| | All users (n=72) | Frequent users* (n=32) | Non-frequent** users (n=40) | |
| Driving | 19% | 12% | 25% | 16% |
| Rides | 73 | 76 | 70 | 38 |
| Taxi | 48 | 58 | 40 | 19 |
| Agency | 22 | 22 | 23 | 11 |
| Van service | 26 | 25 | 28 | 6 |

| <u>Car availability for driving</u> | <u>Percent of users(n=73)</u> | <u>Percent of frequent* users (n=33)</u> | <u>Percent of non- frequent users** (n=40)</u> |
|---|-----------------------------------|--|--|
| No license | 71% | 76% | 68% |
| Always | 18 | 9 | 25 |
| Sometimes | 1 | 1 | - |
| Never | 10 | 12 | 8 |

| <u>Registered for scrip</u> | <u>Percent of users(n=73)</u> | <u>Percent of frequent* users (n=33)</u> | <u>Percent of non- frequent users** (n=40)</u> |
|-----------------------------|-----------------------------------|--|--|
| Yes | 45% | 52% | 40% |
| No | 55 | 48 | 60 |

*Those making five or more bus trips per week.

**Those making fewer than five bus trips per week.

TABLE 4-9. LIFT USER PERSONAL CHARACTERISTICS

| <u>Aids used</u> | <u>Percent of users* (n=72)</u> | <u>Percent of trips** (498 trips)</u> |
|---------------------|---------------------------------|---------------------------------------|
| Manual wheelchair | 57% | 60% |
| Electric wheelchair | 49 | 39 |
| Crutches | 6 | - |
| Cane | 1 | -*** |
| None | 1 | 2 |

| <u>Housing type</u> | <u>Percent of users (n=72)</u> | <u>Percent of trips (498 trips)</u> |
|---------------------|--------------------------------|-------------------------------------|
| Private | 67% | 68% |
| Handicapped housing | 29 | 30 |
| Nursing home | 4 | 2 |

| <u>Age</u> | <u>Percent of users (n=72)</u> |
|--------------|--------------------------------|
| Less than 20 | 4% |
| 20-34 | 47 |
| 35-54 | 32 |
| 55-64 | 8 |
| 65+ | 8 |

*Responses add to more than 100% due to multiple responses.

**Tabulated according to first aid listed.

***Less than 0.5%.

of canes and crutches, the figures in Table 4-9 should be compared to Metro's boarding counts, which show that 8.6% of boardings are made standing rather than in a wheelchair.

4.3 REASONS FOR USE

4.3.1 Switching From Other Modes

As reported in Table 4-8, many users make trips on the bus they used to make on other modes. Table 4-10 shows the reasons respondents gave for switching to the bus. For people formerly travelling by getting rides or using a social agency service, increased independence is the most important reason. For people formerly travelling by driving or by taxi, expense and (related to expense) saving gas are most important.

TABLE 4-10. REASONS FOR SWITCHING TO BUS
(% of Respondents Giving Each Reason)

| Reason | Former Mode | | | | |
|-----------------------------|-----------------|-----------------|----------------|-----------------|----------------------|
| | Drive (n=12) | Rides (n=28) | Taxi (n=14) | Agency (n=8) | Van Service (n=4) |
| Independence | 8% | 79% | 21% | 75% | 25% |
| Less expensive | 33 | 14 | 57 | 25 | 25 |
| Save gas | 50 | - | - | - | - |
| No answer/not sure/other | 8 | 7 | 21 | - | 50 |

4.3.2 New Trips

It is not known precisely how many new trips lift-users are making as a result of accessible bus service. However, in response to a question on whether there is anything they can now do, or do more often, as a result of the service, respondents gave the information reported in Table 4-11.

4.3.3 Effectiveness of Marketing and Outreach

Some data on the effectiveness of the marketing and outreach programs are available from the surveys of lift users and non-users. Users were asked how they learned about the service. Their responses are shown in Table 4-12.

Of the 73 users interviewed, 21 or 29% said that a Metro transit representative had trained them in the proper use of the lift. Of these, 15 or 71% felt the training was essential in helping them to use the lift. Of 73 "potential users" (see Appendix E) interviewed, 33 or 45% had seen or taken part in a

TABLE 4-11. WHAT CAN YOU NOW DO OR DO MORE OFTEN

| <u>Activity</u> | <u>Percent of users (n=73)</u> | <u>Percent of responses (n=118)</u> |
|-----------------|--------------------------------|-------------------------------------|
| Be independent | 25% | 15% |
| Shop | 23 | 14 |
| Entertainment | 14 | 8 |
| Visit | 12 | 8 |
| Get out more | 12 | 8 |
| Get a job | 8 | 5 |
| Go to school | 7 | 4 |
| Recreation | 5 | 3 |
| Nothing | 19 | 12 |

TABLE 4-12. HOW USERS LEARNED ABOUT ACCESSIBLE SERVICE

| <u>How learned</u> | <u>Percent</u> |
|-----------------------|----------------|
| Word of mouth | 25% |
| Saw bus | 21 |
| Newspaper | 18 |
| Social service agency | 17 |
| Television | 15 |
| Bus demonstration | 6 |
| Radio | 3 |
| Other | 7 |

(Multiple responses allowed: 71 users gave 80 responses)

demonstration of the lift, of whom 28 or 85% felt that they would be able to use the lift when making a trip after the demonstration. Those who saw or took part in a demonstration found it very useful; however, the demonstrations do not seem to have been an important factor in attracting riders.

4.4 POTENTIAL USERS

4.4.1 Description of the Potential User Survey

Seattle Metro conducted a survey in November 1980 in which 72 potential users of the accessible bus service were interviewed by telephone or in person. Twenty-eight were contacted from Metro's accessibility mailing list. The remaining 44 returned a mailback card, distributed through ten social service agencies, on which they indicated a difficulty using stairs and an interest in using the bus, and provided a telephone number for the complete interview. The sample includes 11 people who live in a United Cerebral Palsy residential center. The phrase "potential user" is used rather than "non-user" to emphasize that all the respondents had at least some degree of need for and interest in accessible bus service. The mailback card and questionnaire are included in Appendix E.

Given the sampling method used, there is no assurance that the survey respondents fairly represent all potential users. Nevertheless, they are a substantial group who have identified themselves as potential users. Therefore, their characteristics, the reasons they give for not now using the bus, and the changes they would like to see, are of interest in attempting to increase the use of the accessible service.

4.4.2 Need for and Interest in Accessible Service

Of the 72 people surveyed, 85% have extreme difficulty using stairs or cannot use stairs at all (Table 4-13). Therefore nearly all the potential users would need the lift if they were to ride the bus. All of the respondents indicated some interest in accessible service; 71% of them indicated at least one trip purpose for which they would definitely like to use the bus. As shown in Table 4-14, this interest extends across all trip purposes.

TABLE 4-13. POTENTIAL USERS' ABILITY TO USE STAIRS

| <u>Ability to use Stairs</u> | <u>Percent of people (n=72)</u> |
|------------------------------|---------------------------------|
| Moderate difficulty | 15 |
| Extreme difficulty | 26 |
| Can't use stairs | 58 |

Fifty-three percent of the potential users indicated that they "plan to start using the lift buses in the future." On the other hand, 57% of respondents said that at least one reason for not using the lift buses in that they "prefer to use other

TABLE 4-14. INTEREST IN USING LIFT BUSES

| <u>Trip purpose</u> | <u>Percent of respondents making trips for purpose</u> | <u>Percent of those making trips for this purpose who would like to use lift buses</u> | <u>Percent of respondents who would like to use lift bus for this purpose</u> |
|---------------------|--|--|---|
| Work | 31 | 52 | 15 |
| Shop | 78 | 62 | 46 |
| School | 18 | 58 | 10 |
| Recreation/visit | 72 | 60 | 38 |
| Personal/business | 49 | 61 | 39 |
| Medical | 65 | 66 | 38 |
| Other | 17 | 91 | 14 |

means of transportation." Regarding door-to-door service, about the same percentage, 50%, would like to see door-to-door service in addition to accessible fixed-route service, but only 38% would like to see door-to-door service if it replaced fixed-route service.

4.4.3 Personal Characteristics

As shown in Table 4-15, the potential users differ from the respondents to the user survey ("users" for short) in being older than the users, and in making more use of aids other than wheelchairs. These factors might account for a somewhat lower trip rate but do not explain a total lack of bus use. Regarding personal mobility, 47% of potential users said they cannot go out of the house without help; 58% always travel with an attendant, compared to only 26% of the users. No difference in housing arrangements between potential users and users is apparent from the survey responses. The potential users are a fairly low-income group--69% of those who gave their income reported it as under \$10,000 per year (Table 4-16).

4.4.4 Travel Characteristics

Table 4-17 shows the potential users to be a reasonably mobile group of people, although they do not travel nearly as much as the users. The difference in trip rates is probably due, at least in part, to the difference in age distributions already noted. The sample sizes are too small for statistical conclusiveness; however, the potential users appear to drive somewhat more than the users. The potential users definitely make less use of taxis than the users. This is consistent with the lower scrip registration rate for potential users noted previously.

TABLE 4-15. COMPARISON OF POTENTIAL USERS AND USERS

| <u>Age</u> | <u>Percent of potential users (n=72)</u> | | <u>Percent of users (n=72)</u> |
|------------|--|--|--------------------------------|
| Under 20 | 6% | | 4% |
| 20-34 | 28 | | 47 |
| 35-54 | 22 | | 32 |
| 55-64 | 22 | | 8 |
| 65+ | 22 | | 8 |

| <u>Aids used</u> | <u>Percent of potential users (n=72)</u> | | <u>Percent of users (n=73)</u> |
|---------------------|--|--|--------------------------------|
| Manual wheelchair | 58% | | 56% |
| Electric wheelchair | 40 | | 48 |
| Crutches | 13 | | 6 |
| Cane | 11 | | 1 |
| Braces | 7 | | 5 |
| Walker | 4 | | 3 |
| None | 3 | | 2 |
| Other | 1 | | 1 |

| <u>Travel with attendant</u> | <u>Percent of potential users (n=72)</u> | | <u>Percent of users (n=72)</u> |
|------------------------------|--|--------------------|--------------------------------|
| | <u>Now</u> | <u>If used bus</u> | |
| Yes | 58% | 49% | 26% |
| Sometimes | 11 | 17 | 7 |
| No | 26 | 33 | 67 |

| <u>Housing</u> | <u>Percent of potential users (n=72)</u> | <u>Percent of users (n=73)</u> |
|---------------------|--|--------------------------------|
| Private housing | 63% | 67% |
| Handicapped housing | 33 | 29 |
| Nursing home | 4 | 4 |

| <u>Registered for Scrip Program</u> | <u>Percent of potential users (n=72)</u> | <u>Percent of users (n=73)</u> |
|-------------------------------------|--|--------------------------------|
| Yes | 31% | 45% |
| No/no answer | 69 | 55 |

TABLE 4-16. INCOME OF POTENTIAL USERS

| <u>Annual household income</u> | <u>Percent of potential users (n=58)</u> |
|--------------------------------|--|
| Under \$5,000 | 43% |
| \$5,000-\$10,000 | 26 |
| \$10,000-\$20,000 | 19 |
| \$20,000-\$30,000 | 10 |
| Over \$30,000 | 2 |

TABLE 4-17. TRAVEL CHARACTERISTICS OF POTENTIAL USERS AND USERS

| <u>How often go places around town</u> | <u>Percent of potential users (n=72)</u> | <u>Percent of users (n=73)</u> |
|--|--|--------------------------------|
| 4 or more times a week | 42% | 79% |
| 2-3 times a week | 36 | 14 |
| About once a week | 8 | 3 |
| 2-3 times a month | 4 | 1 |
| Once a month or less | 7 | 3 |
| Don't travel at all | 3 | - |

Travel by Purpose and Mode

| <u>POTENTIAL USERS Purpose</u> | <u>Percent making trips by:</u> | | | | | | | <u>All Modes</u> |
|--------------------------------|---------------------------------|--------------|-------------|------------|---------------|-------------------|--------------|------------------|
| | <u>Driving</u> | <u>Rides</u> | <u>Taxi</u> | <u>Van</u> | <u>Agency</u> | <u>Walk/Wheel</u> | <u>Other</u> | |
| Work | 17% | 11% | 1% | 3% | 4% | 1% | 1% | 31% |
| Shop | 22 | 39 | 10 | 4 | 11 | 13 | 4 | 78 |
| School | 7 | 1 | - | 4 | 3 | 1 | 3 | 18 |
| Recreation/ visit | 22 | 51 | 7 | 1 | 1 | 6 | 6 | 72 |
| Personal/ business | 13 | 22 | 7 | 6 | 7 | 10 | 3 | 49 |
| Medical | 15 | 24 | 10 | 8 | 15 | 7 | 7 | 65 |
| Other | 1 | 13 | - | 3 | 3 | - | - | 17 |
| All purposes | 29 | 63 | 16 | 12 | 18 | 19 | 14 | |
| <u>USERS</u> | | | | | | | | |
| All purposes | 19 | 73 | 48 | 26 | 22 | not asked | | |

4.4.5 Availability of Service

In considering service availability it is important to distinguish between bus service in general and accessible bus service. Regarding bus service in general, the potential users do not live further from bus service than do the users--41% live within a block of a bus route, compared to 20% of users; and 41% live three or more blocks from a bus route, compared to 51% of users. However, 25% of the potential users say no lift-equipped buses serve the stop nearest their home, and 32% don't know whether one does or not. The potential users do perceive limited accessible service as an important reason for not presently riding the bus. In responding to possible explanations for not riding, two explanations which were among the most popular were, "the bus stop is not convenient to your home" (58%) and "the bus doesn't go where you want to go" (54%). Only 8% said that they were not aware of the service. Similarly in responding to possible changes to the service which would make the potential users "a lot more likely to use the bus," the three at the top of the list were: "You didn't have to transfer between buses" (48%), "The bus went closer to the places you need to go" (45%), and "The bus stop was nearer to your home" (41%). More frequent service, on the other hand, would make only 28% a lot more likely to use the bus. The fact that 49% identified "waiting outdoors for the bus is too tiring or uncomfortable" as a reason for not using the bus indicates that many people find any amount of waiting a problem.

4.4.6 Barriers to Use

The most important barriers appear to be between the bus stop and potential users' origins and destinations, rather than on the bus itself. As with the users, the potential users expressed a desire for improvements to various features of the lift buses. Yet, of 33 potential users who had seen or taken part in a demonstration, 85% felt they would be able to use the lift when making a trip. Between home and the nearest bus stop, however, 72% of respondents identified one or several obstacles which would prevent them from getting to the stop in good weather. These obstacles included: hills (41% of respondents), curbs (39%), intersections (38%), rough surfaces (28%), lack of sidewalks (6%), steps and distance (4% each). Only 28% said there were no such obstacles between their home and the nearest bus stop. Hills cannot be eliminated but the others can. If all obstacles were removed, only 20% of the respondents would still find it "fairly difficult" to "impossible" to get to the nearest bus stop in good weather.

4.4.7 Conclusions from User/Potential User Comparison

The potential users appear to have somewhat less need of the bus than users, both because they travel less, and because

they drive themselves more. The potential users probably have a harder time getting to and from a bus stop, both because of less personal mobility and intervening barriers. In addition the non-users appear to lack bus service. Additional accessible bus service and a continuing program of accessibility improvements to streets and sidewalks will probably make some of the potential users into users. Many, however, probably have trips which cannot be made easily by bus or will continue to find getting to and from the bus stop too difficult.

4.5 EXPLANATION FOR RIDERSHIP LEVELS

Ridership in Seattle has been very high compared to what many people have come to expect from accessible bus service in most cities. Nevertheless, it may still be the opinion of many observers that 56 or even 125 average daily uses should be considered very light usage when compared to transit use statistics for services other than accessibility. Since this report is primarily concerned with evaluating Metro's experience in comparison with other accessible services, it refers to lift use in Seattle as "very high." Some readers may wish to understand this as a shorthand for "very high compared to other accessible services."

4.5.1 Total vs. Proportional Lift Use

Two measures of lift use are used in this discussion. One is total lift boardings; the other is proportional lift usage as defined in Section 4.1.2. As discussed in that section, it is only when measured as total lift boardings that Seattle lift use really stands out as exceptional. When measured as proportional lift use, the Seattle experience is less exceptional than indicated by the absolute numbers. At least two other systems (AC Transit and Champaign-Urbana) equal or exceed Seattle's proportional lift use. However, even in terms of proportional lift usage, the Seattle ridership is still higher than that of most other accessible bus systems.

4.5.2 Possible but Unlikely Reasons for High Ridership

Before going on to examine the factors which are proposed as reasons for high ridership in Seattle, we consider several other factors which might cause differences in proportional lift use (and therefore ridership) among cities. First, the incidence of wheelchair users (and others who cannot use steps) might be higher in some cities than it is elsewhere. Unfortunately there has been no research which would conclusively establish the range of variation in handicapped incidences. The results of the National Survey of Transportation Handicapped People,* and

*National Survey of Transportation Handicapped People, UMTA Washington, D.C., 1978.

surveys carried out by Crain & Associates and others for particular localities, suggest that the range of variation from city to city is no more than a factor of two--from about 3.6% to 7.6% for all transportation handicapped. According to the National Survey results, the highest incidence occurs in the southern and mountain states. The Pacific Northwest is predicted by the National Survey to have a somewhat below-average incidence. A Crain & Associates survey in Portland, Oregon (which is similar in many ways to Seattle) showed a non-institutional incidence of 5.5%*, or about the national average for mass transit areas as measured by the National Survey. A similar result (5.2%) was obtained for the Oakland/Berkeley service area of AC Transit**, whose accessible bus service has experienced proportional lift usage equal to Seattle's. Whether or not these results carry over to the incidence of wheelchair users cannot be said for certain. A few places are known as centers of handicapped programs or handicapped activism and might be expected to have a higher-than-average incidence of wheelchair users. Examples are Berkeley, CA (served by AC Transit) and Champaign-Urbana. Seattle, however, has no such reputation. All in all, there is no reason to think that Seattle has an unusually large population of wheelchair users.

Favorable weather and topography might also explain high proportional lift use. Seattle does not have a hard winter, as do some other locations. However, the climate is very rainy, and rain does appear to discourage lift use. Seattle is also very hilly, which is definitely a problem for potential lift users. It does not appear that natural conditions would account for especially high proportional lift use.

It is possible that the Seattle system happens to serve the origins and destinations of wheelchair users especially well. Put differently, the trips of Seattle wheelchair users may be more easily served by transit than those of wheelchair users in other cities. The existence of a major accessible housing project in Seattle may support this hypothesis, as is pointed out in Section 4.5.6 below. Other than this project and one other, Metro staff concluded that the handicapped live dispersed throughout the region. Because wheelchair users are such a small percentage of the population (0.15% based on national results) chance concentrations are bound to occur, making certain routes more useful than others to wheelchair users. These concentrations are not generally known, however. Most of Metro's accessible routes were chosen on the basis of high general ridership

*John Crain and W. Courington, Incidence Rates and Travel Characteristics of the Transportation Handicapped in Portland, Oregon, Crain & Associates for UMTA/TSC, Report No. UMTA-OR-06-0004-77-1, April 1979.

**Crain & Associates, "AC Transit Elderly and Handicapped Planning Study," Menlo Park, CA April 1979.

rather than suspected concentrations of handicapped origins and destinations. To sum up, the hypothesis of favorable origins and destinations cannot be completely ruled out as contributing to high proportional lift use, not only in Seattle but also in Oakland/Berkeley and Champaign-Urbana. However, the hypothesis seems fairly unlikely. Moreover, there is no direct evidence in its favor and, as shown in the next few sections, there are sufficient other factors to account for Seattle's level of proportional lift use.

4.5.3 Likely Reasons for High Ridership

In the course of documenting the Seattle accessible bus service, several factors have emerged as the most likely reasons for high ridership. These are:

1. A relatively high overall level of transit use combined with extensive lift-equipped service
2. Relatively reliable service
3. Good service planning
4. Good marketing
5. A very favorable attitude on the part of management, staff and drivers toward the service

Each of these factors, plus some others, are considered in the following sections.

4.5.4 High General Ridership and Extensive Lift Service

This is not an explanation for high proportional lift use, but it is an explanation for high total lift use. Seattle* is the only system so far with extensive lift service, a high overall level of transit use, and good-quality, well-planned and marketed, reliable service. The last three factors are proposed as reasons for high proportional lift use. This level of proportional lift use, combined with high general ridership and extensive lift service produced the exceptional level of total lift use observed.

4.5.5 Reliable Service

The Seattle equipment is more reliable than that used in many accessible systems. It is particularly more reliable than early designs, such as used in St. Louis, one of the first sites to offer accessible service. In St. Louis, between August 1977 and August 1978 an average of 11.3% of all attempted lift

*Joined by AC Transit while this report was in preparation.

boardings were denied,* compared with 1.7% in Seattle. Even in some more recently-installed systems, reliability is much poorer than in Seattle. For example, Connecticut Transit reported 7% of attempted boardings denied in Hartford and New Haven, and 17% in Stamford during the June-September 1980 period; and WMATA reported 11% denied boardings during the same period.** The low denial rate in Seattle, and fairly frequent service, may explain why 73% of those denied boarding in Seattle are willing to just wait for the next bus. This last statistic means that Seattle lift users are able to complete their trip by bus all but 0.4% of the time.

Another measure of reliability is missed accessible runs, i.e., scheduled accessible runs not served with accessible equipment. In Seattle, fewer than 1% of scheduled accessible runs were not served as scheduled during the period studied. In stark contrast, mechanical problems in St. Louis accumulated so that between 6% and 40% of scheduled accessible runs were missed during various periods. In Connecticut, a very low spares ratio has resulted in 12% of accessible runs being missed in Hartford, and 9% in New Haven and Stamford. This unreliability may explain why the Connecticut services show a lower proportional lift use rate (.01% to .03% of total ridership) than Seattle (.07%). One large system with recent experience is WMATA, which reports missing about 20% of scheduled accessible runs.** This may help explain why WMATA's lift use is only about one tenth as high as Seattle's despite about the same amount of service.

Two other systems which appear to have reliable service are Palm Beach and Champaign. Palm Beach reports no missed trips; no data on denied boardings are available. In Champaign about 1% of attempted boardings are being denied. Champaign has higher proportional lift use than Seattle (.08%). Palm Beach's proportional lift use rate of .04% is considerably less than Seattle's. Possible reasons are discussed in Section 4.5.9.

4.5.6 Good Service Planning

Good service planning has contributed to ridership in two ways: by making it possible for service to be reliable, and by focusing on high-volume routes. Regarding the first point, service levels were increased slowly, and never exceeded levels that could be provided reliably. A substantial spares ratio was always kept.

*Teixeira, Diogo, Frank Varker and Robert Bowlin, Applied Resource Integration Ltd., Accessible Bus Service in St. Louis, UMTA/TSC Project Evaluation Series, February 1980.

**Data supplied by Robert Casey, TSC; compiled from evaluation studies in progress.

On the second point, in planning accessible service, many systems have relied on identifying routes which serve identifiable "elderly and handicapped destinations," or which have high levels of reduced-fare ridership. Metro staff concluded that the handicapped live scattered through the city. Therefore routes usable to a large number of general riders are most likely to be useful to many handicapped riders (see Section 3.1.3). Such an assumption would appear consistent with the results of the lift-user survey, which show that lift-users' trip making and personal characteristics are more similar, in many ways, to those of the general transit riding population than to those of most elderly or transportation handicapped persons.

An effort was also made to serve several locations of obvious importance. The major example of such a location is Center Park, an accessible, subsidized housing development built in the late 1960s by Model Cities. Route 7 was made accessible in order to serve Center Park. Route 7 has had the highest level of lift use of any route made accessible. This appears to be partly due to the presence of Center Park on the route. Route 7 is also the route with the highest level of general ridership of all routes made accessible, and serves several popular destinations, including downtown, the University of Washington, and the Broadway retail district.

Another concentration of the handicapped is a United Cerebral Palsy (UCP) residential center which houses 100 people who use wheelchairs. Three routes (22, 305 and 317) pass near the center. Although it is four blocks without sidewalks from the center to a bus stop, some of the residents are known to ride the buses. Also served (by route 6) is a UCP training center near downtown. UCP operates its own transportation service, but does encourage its clients to ride the buses. Route 5 serves several nursing homes. Altogether, 29% of lift users interviewed live in special housing for the handicapped, and 4% in nursing homes.

In summary, while generally following the principle of maximizing lift use by serving high-volume routes, Metro has also been able to take advantage of some concentrations of handicapped residences and destinations.

4.5.7 Good Marketing

No comparison of marketing efforts in Seattle to those elsewhere has been made. Nevertheless, it is clear that Metro has done a good, careful job of marketing the lift service. Part of this is the close and cordial relationship Metro has developed with the handicapped community. As discussed earlier, Metro marketing did not include any advertising, although there has been considerable news coverage of the service. Metro's marketing has consisted primarily of useful information targeted at potential users. Examples include the detailed instructions on how to use

the lift service (Figure 3-11); integration of lift service information into the function of the regular telephone information service, including the ability to identify specific bus stops at which the disabled can board and deboard (Section 3.8.1); the lift demonstrations and the lift bulletin (Section 3.8.2). The marketing effort was not geared to convincing people to use the service. Instead it was designed to help those who were able to use the service and wanted to use it to do so effectively and without mishap. Metro has avoided the pitfall of overselling the service while it was still developing, which can lead to bad experiences and a poor reputation among users and potential users.

4.5.8 Favorable Attitude and Commitment

Metro's management, staff and drivers have shown a high degree of commitment to making accessible service work. This commitment is reflected in a favorable attitude on the part of staff and drivers. A particularly noticeable example is the Driver Task Force (Section 3.1.4) which met on Metro time and provided an important link between staff and the operators. Other signs of management's commitment are the extensive work put into lift selection and testing (Section 3.1.2); the careful approach to service planning employed, including maintenance of a high spares ratio (Section 3.4.1); and the great detail with which policies and procedures were worked out (Section 3.6). The most convincing evidence (but also the hardest to document) to those who worked on this evaluation was the positive attitude and commitment on the part of staff at all levels which was encountered. The positive attitude of the drivers toward most aspects of the service is documented in Section 3.7. Driver attitudes are particularly important in retaining users, especially if users experience any sort of difficulties in their initial attempts at using the lift. Positive attitudes, and the relative reliability of the service, may explain why 73% of those denied boarding in Seattle are willing to just wait for the next bus.

4.5.9 Other Factors

Two systems which appear to offer reliable service, but have much lower proportional lift use than Seattle, are Palm Beach and Orange County. What reasons can be found for this? One is the support of the handicapped community. The handicapped community in Seattle has been very strong in support of accessible service, and has participated actively in its planning and implementation. In contrast, the handicapped community in Palm Beach has had very little involvement with the transit operator.* In Orange County the handicapped community has been far from unanimous in support of fixed-route accessibility.

*Larry Englisher, Multisystems, Inc; based on evaluation work in progress.

Another factor is the presence of a competing service in Orange County. Orange County also operates a Dial-a-Lift service which carries six times as many wheelchair passengers as the accessible fixed-route service.* Metro does have a taxi scrip program, including some wheelchair-accessible taxi-vans; however this service is fairly expensive compared to fixed-route bus service. A third factor is the presence of barriers on streets and sidewalks. No information is available to suggest that there are more or fewer than average barriers in Seattle or Orange County. In Palm Beach, according to the evaluator of the accessible-bus SMD project, high-speed auto routes and a lack of sidewalks and traffic signals in many of the low density areas served make access to the system difficult.

4.5.10 Opinions of Handicapped Spokespersons

Five spokespersons of the Seattle handicapped community were interviewed by telephone to get their opinions on the reasons for Seattle's relatively high ridership. All use wheelchairs and have been actively involved in bringing accessible service to Seattle. Four have been members of Metro's steering committee for the accessible service. The fifth is unconnected with Metro and was involved in bringing a suit against Metro in the middle 1970s to force their acquisition of accessible buses. None of the individuals interviewed had had extensive experience in other cities, but most were familiar with other places, e.g., St. Louis, from trips or reports of friends.

Individuals varied in the degree that they stressed one point or the other, but there was general agreement that the service was a success and the following factors were very important in making it one:

- Involvement of the disabled community in all phases of providing the service, i.e., defining needs, choosing a lift, planning routes and level of service, implementation, and monitoring
- A good combination of origins and destinations served by the service, plus curb cuts and accessible buildings in the communities
- Reliable and safe service
- Positive attitudes and commitment of Metro personnel to make the service work, openness to suggestions by the disabled community, and willingness to involve handicapped persons in the planning process

*Orange County Transit District, "Section 504 Annual Status Report," December 1980.

In addition, some spokespersons emphasized the fact that Metro was a young and dynamic organization. The presence of personnel not firmly set in their ways was viewed as important in Metro's willingness to respond to the needs of the handicapped community. However, an equally important factor that some spokespersons noted was the advocacy role played by the handicapped community. The Seattle community was virtually unanimous in its decision to pursue accessible mainline service instead of a separate transportation system for the handicapped. The crucial combination here is the willingness of the disabled community to insist on their civil rights and the openness of Metro and the Seattle political system to do something about their demands.

Other points mentioned by one or two persons include:

- Except for subsidized taxicabs, there was no handicapped and elderly transportation prior to the accessible service. Thus it was possible to rally a lot of support for this system.
- Seattle weather, while not ideal, is not a barrier to using the service.
- There is a strong desire among the disabled advocates for integration of disabled persons into the mainstream, causing them to push for accessible transit service instead of a separate system.
- The lift was selected carefully after an inspection of the equipment other transit properties were planning to use.
- The organization of the Seattle disabled community is not unusual, but their agreement on the need for accessible service was very important.
- The drivers are not perfect but generally show competence in operating the lift and cooperate with users.
- Service is sufficiently reliable to use without needing a car or backup transportation.
- Consciousness raising by early advocates was very important in encouraging the disabled to speak out for the service.

- The handicapped and elderly survey around 1975 was important for creating an awareness of needs.

Some of the spokespersons discounted the role of publicity in the system ridership and noted a need for more publicity and outreach training in how to use the system. No one was sure if handicapped persons in Seattle took more trips in general than their counterparts in other cities.

5. SERVICE QUALITY

This chapter examines reliability and ease of use of the lifts from the passengers' point of view. Mechanical reliability, repair records, ease of driver operation, and impact on schedules are treated in Chapter 6, "Impact on Metro." Generally, although the service has had some problems, and lift users have had some occasion for complaints, the service has been very reliable compared to what has been observed in some of the other sites which have been documented.

5.1 RELIABILITY

5.1.1 Passengers Passed Up

As part of the six lift-use counts described in Section 4.1.1, drivers recorded the number of lift passengers passed up due to an overload condition or lift malfunction.* The results are shown in Table 5-1.

TABLE 5-1. LIFT PASSENGERS PASSED UP

| <u>Dates</u> | <u>Overloads</u> | | <u>Malfunctions</u> | |
|-----------------------------|------------------|-------------------|---------------------|-------------------|
| | <u>Pass./Day</u> | <u>% of Pass.</u> | <u>Pass./Day</u> | <u>% of Pass.</u> |
| Feb. 23-Mar. 10, 1980 | 0.2 | 0.6% | 1.2 | 3.3% |
| Mar. 29-Apr.6 | 0.4 | 0.9 | 1.2 | 2.4 |
| May 17-23 | 0.5 | 0.9 | 2.0 | 3.7 |
| July 12-24 | 0.5 | 0.8 | 0.5 | 0.8 |
| August 16-21 | 0.3 | 0.4 | 0.5 | 0.9 |
| Oct. 14-19 | 0.5 | 1.0 | 0.5 | 1.0 |
| Feb. 28 - Mar. 5, 1981** | 0.8 | 0.8 | 2.0 | 2.2 |
| Apr. 25-30 | 1.3 | 1.3 | 0.8 | 0.8 |
| July 11-16 | 1.3 | 0.9 | 3.3 | 2.4 |

*In a few cases, passengers passed up due to assignment of non-accessible equipment were reported in the "malfunction" category. The term "overload" can refer to both wheelchair positions being occupied or to a bus being too crowded to load a passenger in a wheelchair.

**Accessible service increased from 26 to 42 routes on January 31, 1981.

They indicate that relatively few passengers are passed up due to overloads or malfunctions. The rate of malfunctions dropped markedly beginning in July 1980, indicating that Metro had achieved some success in getting rid of initial "bugs" by that time. As might be expected, the rate of overloads was relatively stable or slightly increasing. The last three lines in the table show the effect of the major increase in accessible service on January 31, 1981. The rate of malfunctions increased to a level almost equal to that observed in the first phase of lift service. The increasing rate of overloads may reflect the continued rise in lift usage, including an increased rate of use on the routes which already had accessible service before 1981.

5.1.2 Missed Assignments

One reason why a passenger might be passed up is that a non-accessible coach may have been assigned to a designated accessible run. This happens occasionally due to reasons such as lack of functioning accessible coaches (often due to non-lift related problems), or accessible spares having been previously assigned to non-accessible service. Over the four months from June through September 1980, an average of .75 accessible runs per day were served by a non-accessible coach (see Table 5-2 for detail).* Averaging together weekdays and weekends, there were about 95 daily scheduled accessible assignments during this period, so about 0.8% of accessible assignments were missed.

TABLE 5-2. ACCESSIBLE RUNS SERVICED BY A NON-ACCESSIBLE COACH

| <u>Runs/Day</u> | <u>% of Days</u> |
|-----------------|------------------|
| 0 | 53% |
| 1 | 25 |
| 2 | 16 |
| 3 | 3 |
| 4 | 2 |

When the major accessible service increase was implemented in early 1981, the rate of missed assignments rose temporarily, because many of the new buses required non-lift related warranty

*This analysis is based on dispatch records kept by Metro showing which coach was assigned to each run every day. The number of runs designated accessible which were assigned non-accessible coaches was tabulated for all the days from June to September by Crain & Associates.

service. In the lift-use counts conducted by Metro for four days between February 18 and March 5, 1981, an average of 2.75 scheduled accessible runs were reported served by non-accessible equipment each day.* Since the amount of lift service had nearly doubled, however, this still represents a low rate of missed assignments. In the next lift-use counts, for five days between April 25 and 30, 1981, the rate of reported missed assignments was only 0.25 per day.

5.1.3 Passenger Experiences

These reported rates all seem quite low. For a regular user, however, they are high enough to guarantee an occasional problem. Of the 73 lift users surveyed in November 1980, 54, or 74% had been unable to board at least once. The reasons they reported are shown in Table 5-3.

TABLE 5-3. REPORTED REASONS FOR FAILURES TO BOARD

| <u>Reason</u> | <u>Pct. of Respondents</u> | <u>Pct. of Respondents Encountering More Than Once</u> |
|---------------------------------------|----------------------------|--|
| Lift Inoperative | 52% | 41% |
| Bus too crowded | 28 | 24 |
| No lift on bus | 25 | 18 |
| Driver refused | 24 | 14 |
| Cars in the way | 7 | 6 |
| Unable to maneuver onto lift | 7 | 4 |
| Wheelchair positions already occupied | 7 | 4 |
| Driver didn't know how to use lift | 6 | 0 |
| Other | 7 | 0 |

*This figure is based on voluntary reporting by drivers on scheduled accessible assignments. Over 90% of drivers returned the cards used for reporting; nevertheless, there may be some underreporting of missed assignments (see note, Section 4.1.1).

It should be remembered that passengers wishing to board will often not be in a position to know the actual reason they were not able to board. For example, the distinction between "bus too crowded" and "wheelchair positions already occupied" may be a hard one to make. Likewise, the category "driver refused" may represent a variety of reasons behind the refusal, including cases of attempting to board at stops or on runs other than those designated accessible.

When lift passengers are unable to board, or are denied boarding, what do they do? In most cases, Metro takes no special action, such as sending a supervisor to give the person a ride. Of 59 lift users surveyed who had been unable to board at one time or another, the vast majority, 43, or 73% said that they just waited for the next bus. Table 5-4 shows all the responses.

TABLE 5-4. WHAT LIFT USERS DID AFTER BEING UNABLE TO BOARD

| | <u>% (n=59)</u> |
|---------------------|-----------------|
| Waited for next bus | 73% |
| Took a taxi | 7 |
| Didn't make trip | 5 |
| Got a ride | 3 |
| Other | 12 |

5.1.4 Complaints

In the ten months from January to October 1980, passengers made a total of 133 complaints related to lift service. The rate of complaints dropped continuously over this period, so that for the five most recent months complaints averaged 9 per month. Initially the majority of complaints were concerned with equipment problems. Most recently most complaints were over the design of the service, e.g., schedules, routes, shelters, etc. (49% in the five most recent months) and operations, primarily missing the deboarding stop (33% in the five most recent months). Complaints about equipment were insignificant for the last five months (a total of two), and complaints about drivers have never been significant (eight in ten months).

5.2 SAFETY

Safety is of special importance for lift users in three matters: waiting for the bus, riding the lift, and staying in place while the bus is in motion.

5.2.1 Waiting

Safety while waiting for the bus is a concern of all bus riders, but especially for lift users, because they may feel more vulnerable than non-handicapped people, and because they often have to wait longer than non-handicapped people. However, 91% of the lift users surveyed described feeling safe while waiting for the bus as "little or no problem;" 7% described it as a "moderate problem," and 1% (one respondent) described it as a "serious problem."

5.2.2 Riding the Lift

On the subject of riding the lift, 96% described safety as "little or no problem." However, 11% of respondents reported a moderate or serious problem immobilizing their wheelchairs while riding the lift. Three respondents said they needed help. When asked about the importance of various changes, however, many lift users felt there was room for improvement in the lift design in areas related to safety, including a wider safety gate (8%) (see more below), smoother operation (3%), a wider lift (8%), and general improvements in safety and maintenance (18%).

5.2.3 Riding the Bus

Adequately securing wheelchairs so they cannot move around on the bus has been a concern from the start, and a matter of changing designs and policies. As originally designed, the securement mechanism consisted of one claw clamp, which automatically closes around the window-side wheel when the passenger backs the chair into the clamp. This arrangement prevents motion toward the aisle; motion in the direction of the window was thought not to be a problem.

After the first accessible buses were delivered, tests showed that both sides should be secured, and that some chairs did not fit into the claw clamp, or did so only with difficulty. Metro mechanics solved the problem by installing modified motorcycle "cargo straps," which hook onto the frame of a chair and are then tightened. There are two straps in each securement position. The aisle-side one is always used; the window-side one is required if the claw clamp is not or cannot be used.

Each securement position also has a seat belt. Metro originally required its use, but later made it optional. (See further discussion in Section 3.6.3, "Driver Responsibilities.")

The securement arrangements, while sometimes inconvenient or hard to use (see 5.3, "Ease of Use") do appear to provide a safe and secure ride. Of the 73 lift users interviewed, all but one described feeling safe on the moving bus as "little or no problem." One lift user described it as a "moderate problem."

5.2.4 Accidents and Claims

Metro staff indicate there have been four accidents or incidents involving possible injury to lift users since the inception of the lift service. One of these has developed into a claim against Metro. Current settlement negotiations prevent release of information about the claims because such information could affect the outcome. The other accidents have been comparatively minor, involving things such as a person's fingers getting pinched while operating the securement devices.

Complete reports are filed on all accessible service incidents, although these are not summarized in a form which could be used for this evaluation. Metro staff feel that accidents and claims relating to lift service have been minimized through an intense interdepartmental cooperation to foresee and adjust service to the needs of the handicapped. Metro staff feel that, considering the level of lift usage, the frequency of accidents or claims is well below that experienced with able-bodied passengers boarding and alighting.

5.3 EASE OF USE

While the accessible service is quite clearly very usable and generally well-designed in the view of most users, many, nevertheless, identified features that could be made more convenient or less difficult to use. The features requiring change or presenting a problem to the most lift users are identified in Table 5-5. The most pressing need is for more curb cuts. Also, under the headings "Getting to/from home/destination bus stop," many respondents mentioned a need for more curb cuts.

TABLE 5-5. FEATURES REQUIRING CHANGE OR PRESENTING A PROBLEM

| Feature | % of Respondents Saying Feature Either Requires Change or is a Problem (n=73) | % of Respondents Saying Feature is Very Important to Change or a Serious Problem (n=73) |
|---|--|---|
| Curb cuts | 95% | 88% |
| Number of routes | 92 | 87 |
| Number of buses | 87 | 73 |
| Tie downs | 55 | 28 |
| Driver assistance | 49 | 21 |
| Interior arrangement | 48 | 19 |
| Getting to/from home bus stop | 45 | 18 |
| Getting to/from desti- nation bus stop | 41 | 10 |
| Lift design | 39 | 18 |
| Crowding | 38 | 22 |
| Weather | 33 | 6 |

In addition to a general desire for more service, the area that seems most susceptible to improvement is the process of getting to and from the wheelchair positions, and securing and unsecuring the wheelchairs. Whenever a respondent indicated that a feature posed a problem or required a change, the interviewer asked, "What is the nature of the problem?" or "What changes would you like to see?" On the subject of the tie downs, some lift users regard it as a problem that the driver or someone else has to help them tie down (28% of all respondents).* Others focused on the

*In interpreting these percentages, bear in mind that they represent volunteered comments rather than responses to direct questions, as in Table 5-5.

difficulty of using the tie down straps (15%) and of fitting into the claw clamps (14%). On related issues, users remarked on difficulty maneuvering in the narrow aisle (18%),* the location of the wheelchair position (13%), and a need for more wheelchair positions (11%). On the issue of weather, 19% requested more shelters. Difficulty getting to and from the bus stop seems primarily due to distance and traffic (mentioned by 26%), in addition to the lack of curb cuts already mentioned.

Regarding the lift design, most comments were directed towards generally improved maintenance (18%). Several respondents (11%) remarked on problems with the safety gate getting in the way as a result of not dropping down all the way when the lift is fully lowered. The hair trigger switch which caused the gate to lower was a constant maintenance problem. A new design for lowering the safety gate has been installed by Metro maintenance (see 3.5.4).

*The most difficult maneuvering problem is negotiating the turn between the lift and the aisle. Space is restricted in the vicinity of the driver's seat. In addition, wheelchairs easily get stuck on a pole located directly at the top of the stairwell, between the stairwell and the first side-facing seats.

6. IMPACT ON METRO

This chapter discusses equipment reliability from Metro's point of view rather than users, the impact of lift service on schedule reliability, and the cost of lift service.

6.1 EQUIPMENT RELIABILITY

Generally Metro is very pleased with the lift. Although there were some problems with the lifts initially, Metro staff feel that lift reliability has improved. Engineering and repair supervisory staff described the lift reliability with terms ranging from "pretty sound" and "relatively good," to "excellent" and "exceptional."

6.1.1 Frequency of Repair

Table 6-1 shows the number of "bad orders" and "trouble calls" written in the months June through September 1980.* A bad order is written whenever a coach needs repair. A trouble call is written for any problem which interrupts revenue service. During the four months for which data were tabulated, lift-related problems accounted for 6% of all bad orders and trouble calls combined, and 12% of all trouble calls.

TABLE 6-1. FREQUENCY OF REPAIR

| <u>Month</u> | <u>Bad Orders and Trouble Calls</u> | <u>Trouble Calls Only</u> |
|--------------|---|-------------------------------|
| June | 157 | 52 |
| July | 178 | 56 |
| August | 174 | 70 |
| September | <u>144</u> | <u>40</u> |
| TOTAL | 653 | 218 |

The 163 accessible coaches averaged about 1000 miles of total service per week. Since the months shown in Table 6-1 include 17 weeks, the implied frequency of repair is once per 4200 bus-miles, with a service interruption once per 12,700 bus miles. During the period in question, we estimate there were approximately 108,000 route-miles of accessible service offered per week.

*Tabulated from computerized maintenance records provided by Metro.

Therefore, the repair frequency would be once per 2800 miles of accessible service.

In terms of lift boardings, at about 63 boardings per day between June and September, there was one lift repair for every 11.8 lift boardings, and one lift-related service interruption for every 35.3 lift boardings. It is not known how many lift-related service interruptions occurred as a result of an attempted lift use. However, at least some of the service interruptions were independent of attempted usage since, otherwise, one interruption per 35.3 boardings would imply a malfunction for 2.8% of boardings, which is considerably higher than the rate shown in Table 5-1 for the period June to September 1980.

The analysis of repair costs presented in 6.3.3 below shows a total of 590 maintenance hours charged to lift repairs in June, July and August. Based on the total of 509 bad orders and trouble calls shown in Table 6-1, for those months, an average time to repair of 1.2 hours is implied.

6.1.2 Discussion of Lift Problems

Metro has not kept any records of the nature of lift problems or repairs. However, several knowledgeable staff members provided their impressions of the most frequent problems. During the early stages of implementation, the operation of the safety gate and related systems was very troublesome. These systems have now been redesigned and are no longer a significant problem. The lift mechanism and the stowed platform are located underneath the right front of the bus chassis. The clearance between the lift and the ground is only seven inches, which occasionally causes the bus to bottom out. For this reason or others, the worm gear which moves the platform in and out of the stowed position has gotten cracked a few times. Also, dirt in the tracks on which the platform rides in and out of the stowed position occasionally causes the lift to jam up. Jiggling the lift by hand or cleaning out the dirt usually solves this problem. Finally, the lift is prone to damage from accidents involving the right front of the bus. Sometimes the entire assembly has had to be replaced.

6.2 SCHEDULES

Lift operations do not appear to have had any significant effect on schedules or on-time performance. No extra recovery time was added to schedules because of accessible service. Metro's scheduled recovery time has been adequate to absorb delays given the level of demand which has been experienced.

Evidence for the lack of impact on on-time performance comes from point checks made by Metro checkers, as summarized in Table 6-2.* The data shown are for accessible and inaccessible trips on accessible routes only between May 27 and September 12 (i.e., the summer sign-up). During this time daily boardings averaged 63. Since there were about 1033 accessible trips per day (averaging

*Summarized from computer tabulations provided by Metro's scheduling department.

over a whole week), a little less than 6% of the accessible trips observed should have had a lift use. The figures in Table 6-2 for all accessible routes may indicate a very slight increase in trips between three and four minutes late; however, the number of trips involved (1.1%) does not approach the 6% of trips which probably had a lift use. Even more significant, the figures for route 7, the route with the heaviest lift use, show no increase in the number of late trips.

TABLE 6-2. ON-TIME PERFORMANCE

| <u>Minutes Late</u> | <u>All Accessible Routes</u> | | <u>Route 7</u> | |
|---------------------|---|--|--|--|
| | <u>% of Non-accessible Trips (n=20,348)</u> | <u>% of Accessible Trips (n=9,418)</u> | <u>% of Non-accessible Trips (n=2,185)</u> | <u>% of Accessible Trips (n=1,671)</u> |
| Less than 1* | 38.6% | 38.3% | 35.7% | 38.5% |
| 1- 2 | 26.6 | 26.9 | 26.7 | 24.6 |
| 3- 4 | 16.4 | 17.5 | 16.9 | 15.4 |
| 5- 6 | 8.9 | 9.0 | 9.7 | 8.8 |
| 7- 8 | 4.4 | 3.8 | 5.0 | 5.4 |
| 9-10 | 2.1 | 2.1 | 2.4 | 2.5 |
| 11-12 | 1.1 | 1.0 | 1.4 | 1.9 |
| 13-14 | 0.6 | 0.4 | 0.8 | 0.8 |
| 15-16 | 0.4 | 0.3 | 0.7 | 0.5 |
| 17-18 | 0.2 | 0.2 | 0.1 | 0.4 |
| 19-20 | 0.2 | 0.2 | 0.1 | 0.3 |
| More than 20 | 0.5 | 0.4 | 0.5 | 0.8 |

In the opinion of the drivers, the schedule impact of lift use is somewhat greater but still not great. Of 306 drivers surveyed, 84% agreed that use of the lift caused them to be behind schedule for the current trip only. Since most drivers estimated the time to board a wheelchair passenger as from 1-3 minutes (45%) or from 4-5 minutes (49%), a somewhat greater total impact than that revealed in Table 6-2 would be implied.

There are several factors which may contribute to the lack of observed schedule impact. First, Metro's scheduled recovery times may be more than adequate. The amount of recovery time in Metro's schedules was estimated for a sample of nine routes with accessible service. It was estimated that, during the summer sign up, the average layover was 15 minutes and the average time between layovers was an hour and 18 minutes (not including the layover).

*Includes early

Detail is provided in Table 6-3. In addition, a slightly higher fraction of off-peak trips than peak trips are accessible, and lift users may prefer to ride in the off-peak. Since off-peak trips probably have fewer schedule problems than peak trips, the result could be to hide some schedule impact from lift use in Table 6-2. Finally, Metro personnel feel that the Flyer coaches, which are used on accessible service, are faster than the coaches used in non-accessible service, and can therefore get back on schedule more easily.

TABLE 6-3. SCHEDULED RECOVERY TIME

| <u>Route</u> | <u>Avg. length of layover</u> | <u>Avg. platform time between layovers</u> |
|--------------|-----------------------------------|--|
| 5 | 13.5 mins | 84.0 mins |
| 6 | 12.1 | 50.7 |
| 7 | 14.0 | 71.5 |
| 17 | 22.9 | 111.1 |
| 18 | 16.0 | 75.4 |
| 19 | 14.2 | 92.7 |
| 107 | 19.0 | 137.8 |
| 150 | 19.2 | 109.5 |
| 317 | 7.9 | 53.1 |

6.3 COST

Cost has been estimated for capital, start-up and operations. Start-up costs are one-time costs which do not have to be repeated to maintain service. Operating cost includes staff time and other expenses which can be expected to continue indefinitely. Finally, a cost per trip has been estimated, first based on operating cost only, and then including amortized capital cost. All the estimates are based on the 163-bus level of service during the summer of 1980. The effects of later service additions are discussed but not formally estimated.

6.3.1 Capital Cost

The accessibility features of Metro's Flyer coaches include:

- Lift-U lift (1)
- Headpad over door (1)
- Fold-up seats (4)
- Cargo straps (4)
- Claw clamps (2)
- Special pullcord (2)

The lift is by far the most expensive item. Its installed cost to Metro is estimated as \$5700 on the original order of 143 coaches. Flyer estimates the installed cost of a Lift-U lift as of late 1980 as \$7000 to \$7500. Of the remaining items, Metro buys, modifies and installs the tie-down straps. They cost \$12 a pair. The headpad was originally installed by Metro, but is now being supplied by Flyer. The Flyer representative considers its cost and the cost of the remaining items as insignificant compared to the cost of the lift. For the sake of completeness, we have assumed that these items add \$500 to the price of a coach.

Using the \$5700 figure for the initial 143 coaches and \$7250 for the remaining 20 used during the study period, and adding \$500 per coach for miscellaneous items, the total capital cost for accessibility on 163 coaches is approximately \$1,040,000.

6.3.2 Start-up Costs

The labor component of start-up cost has been estimated based on interviews with Metro staff. Additional start-up costs which have not been estimated include: printing, use of buses for zone marking and outreach (about 300 vehicle-hours), use of camera to produce ID's at outreach sessions, and miscellaneous materials. One non-labor cost which was estimated is about \$1000 for approximately 5,000 reflectorized stickers applied to bus stop poles to mark them as accessible.

As far as possible the start-up costs shown are those which apply to the 163-bus level of service during the summer of 1980. Costs for much earlier accessibility planning efforts, not directly related to the service actually implemented, were not included. Examples are the "ten-bus" test program, and general elderly and handicapped planning efforts going back to 1975. On the other hand, many of the activities shown apply to additional accessible service beyond the 163-bus level. Such activities include lift selection, developing the training program, outreach, marketing/driver relations, the driver task force, and customer relations training.

Table 6-4 shows start-up time and approximate labor costs by activity. The cost figures, in very round numbers, include fringe benefits and distributed paid time off. The activity category is fairly self-explanatory, with the exception of "Marketing/customer relations." This activity represents a full-time driver detailed to developing accessible service, whose activities included working on the zone marking and outreach programs, serving on the driver task force, and acting as a liaison between staff and drivers.

TABLE 6-4. START-UP LABOR COSTS

| <u>Activity</u> | <u>Person-Months</u> | <u>Cost</u> |
|--|----------------------|------------------|
| Lift selection | 4 | \$15,000 |
| Planning | 6 | 15,000 |
| Develop training program | 6 | 20,000 |
| Train drivers | 6 | 15,000 |
| Zone marking | 2 | 5,000 |
| Outreach | .5 | 1,000 |
| Marketing/driver relations | 17 | 38,000 |
| Driver task force | 4 | 9,000 |
| Lift trouble-shooting & maintenance development | 8 | 30,000 |
| Customer relations training | 1 | 3,000 |
| Other staff time | 6 | 20,000 |
| | <u>60.5</u> | <u>\$171,000</u> |

Accessible service additions beyond the 163-bus level have involved and will continue to involve additional start-up costs. In particular, there are continuing start-up costs for driver training, zone marking and lift trouble-shooting. The major categories are driver training and lift trouble-shooting. By the time full accessibility is reached, about three times as many drivers will have to be trained as had to be for the initial service level. Lift trouble-shooting, including installation monitoring, continues to require a full-time engineer, particularly on the electric trolley buses and articulated buses.

6.3.3 Operating Costs

Operating cost has been estimated under the categories of maintenance and other staff time. Another operating cost, insurance, was considered. However, according to Metro staff,

insurance costs and reserves set aside against claims have not increased due to accessible service. Table 6-5, which is based on figures supplied by Metro, shows the estimated annual staff time and cost (excluding maintenance) for the 163-bus level of service. The scheduling department feels that accessible service takes staff time because the accessible equipment needs to be assigned to the correct assignments at each sign-up (three times each year). Planning time is required because of continuing service adjustments. Operations control must handle incidents involving accessible service. There is a continuing marketing function in explaining service changes to old users and the service in general to new users. Finally, all newly-hired drivers are being trained for accessible service.

TABLE 6-5. STAFF AND OPERATOR TIME
TO MAINTAIN 163-BUS ACCESSIBLE SERVICE

| <u>Activity</u> | <u>Full-time Equivalents</u> | <u>Annual Cost*</u> |
|--------------------|------------------------------|---------------------|
| Scheduling | 1.0 | \$38,000 |
| Planning | .1 | 3,500 |
| Operations control | .1 | 3,500 |
| Marketing | .3 | 10,000 |
| Driver training | 0.5 | 6,500 |
| TOTAL | 2.0 | \$61,500 |

Annual maintenance costs have been estimated based on accounting records supplied by Metro for June, July, and August 1980. A cost per lift was estimated based on 163 coaches, the number operating during the summer of 1980. The number of operating coaches was used, as opposed to the peak number of coaches in use on accessible runs (90), because all coaches were used on accessible runs at various times, because charges were not accounted separately according to type of service, and because repair needs can develop as a result of lack of use.

There are four elements to maintenance cost: repair labor, preventative maintenance labor, trouble calls, and parts. Reasonably accurate records are kept of repair costs, and of the number of trouble calls. The figures on repair labor and cost are summarized in Table 6-6.

*Includes salaries, fringe benefits and paid time off.

TABLE 6-6. REPAIR LABOR AND COST FOR LIFTS

| | <u>Repair Cost (\$)</u> | <u>Repair Labor Hours</u> |
|---|-------------------------|-------------------------------|
| Three months total | \$ 9,523 | 590 |
| Est. annual total | 38,092 | 2362 |
| Annual per coach | 234 | 14.5 |
| Est. daily total (based on 260 workdays per year) | 147 | 9.1 |

The dollar figures shown include labor, overhead, overtime, and distributed paid time off. They do not include time which was paid by Lift-U as part of the warranty arrangement.* The hours worked are equivalent to slightly more than one full-time mechanic. In order to provide a feeling for the size of the repair cost for lifts, comparable annual costs were tabulated from Metro's records for three other major mechanical systems, and for the entire vehicle, as shown in Table 6-7. All costs are for the same 163 accessible Flyer coaches.

TABLE 6-7. ANNUAL REPAIR COST FOR LIFTS AND OTHER SYSTEMS

| <u>System</u> | <u>Est. Annual Cost</u> | <u>Cost/Coach</u> | <u>% of Total</u> |
|----------------------|-----------------------------|-------------------|-------------------|
| Lifts | \$ 38,092 | \$234 | 10% |
| Windshield Wipers | 16,784 | 103 | 4 |
| Brakes | 135,128 | 829 | 34 |
| Engine | 37,716 | 231 | 9 |
| Entire vehicle | \$400,980 | \$2460 | 100% |

*According to the Lift-U Vice President for Marketing, warranty service has cost Lift-U about \$50 per lift. He feels that the cost would be higher were it not that most of the lift components are purchased rather than manufactured by Lift-U. Therefore they are covered under warranties from their various suppliers. Warranty cost has not been added to maintenance cost because it is already included in the purchase price of the lift.

The lift repair cost is much lower than reported in many other transit systems, but is still a major part of total repair costs. As a percentage of purchase cost, annual lift repair cost is 4.1%, compared to all maintenance costs, which are 2.7% of the vehicle purchase cost annually.

Metro's accounting records indicate a total of \$776 annually for lift parts on the 163 coaches (based on expanding three months of data). This figure seems very low. One reason is that repairs requiring major parts have mostly been made by Lift-U up until now.

Preventive maintenance consists of three parts: daily cycling of the lift, a 1000-mile lube, and the F inspection, a 27,000-mile lube and inspection. Cycling the lift is scheduled as part of the fueling and washing of the buses. Although it must take a couple of minutes, no extra time or personnel have been scheduled for the task by Metro. The 1000-mile lube takes about ten minutes and is required about once a week on each coach (about .7 hours per coach per month). The F inspection takes an hour to an hour and a half, and is required about every seven months (about .2 hours per coach per month). Allowing for the lift cycling, a reasonable estimate of total preventive maintenance time per coach was considered to be about one hour per month per coach. From records supplied by Metro's accounting department, it was estimated that an average hour of maintenance labor costs Metro \$16.13, allowing for paid time off, fringe benefits, and time and a half for over-time.* One hour per month would cost about \$194 per year.

When a lift problem interrupts revenue service (a "trouble call") additional time is required, either by a supervisor, or driver of a replacement coach, or a mechanic making a road call. About one hour of time per trouble call has been assumed. There were 218 lift-related trouble calls in four months, according to Metro's records, implying 654 labor hours annually. These are estimated to have cost Metro approximately \$10,500, which is \$64 per coach per year.

The total estimated lift-related maintenance cost per coach per year is therefore:

| | |
|------------------------|-------|
| Repair labor | \$234 |
| Preventive maintenance | 194 |
| Trouble calls | 64 |
| Parts | 5 |
| TOTAL | \$497 |

*Theoretically, a higher rate could be used to represent the true resource cost. When Metro performs repairs covered under warranty, it charges \$23.68 per hour for maintenance labor. This figure is meant to cover not only direct labor costs, but also the cost of fixed facilities, management, accounting and other aspects of overhead. The lower figure has been used here to make the analysis comparable to those conducted for other systems with accessible service.

Total labor on repairs, preventive maintenance and trouble calls is about 31 hours per coach per year, or 2.4 full-time equivalents for the 163-coach accessible fleet. In addition, Metro employs a full-time lift engineer whose time was included in the calculation of start-up cost. Much of his time was spent troubleshooting the first lifts during the first year of accessible service and designing the preventive maintenance program. In recent months his time has been taken up with the installation of more recent orders. His time does not appear to represent a continuing element of maintenance cost, but a start-up cost associated with each increment of new accessible service.

Rounding maintenance cost up to \$500 per coach, annual total operating cost for the 163-bus level of service is estimated as:

| | |
|---------------------------------|---------------|
| Maintenance (163 buses @ \$500) | \$81,500 |
| Other staff time | <u>61,500</u> |
| TOTAL | \$143,000 |

6.3.4 Cost per Trip

Cost per trip has been calculated based on the six lift-use counts conducted before the major service increase in January 1981. The six counts show average daily boardings of 56.3, or 20,500 per year. The first of these counts was conducted only shortly after the 23-route level of service was reached, and is lower than any count taken since. Further, lift use on the routes which were accessible before January 1980 has continued to rise in more recent counts. Therefore, 20,500 boardings per year is a very conservative figure on which to base a cost per trip estimate.

Using the figure computed at the end of the last section, operating cost per unlinked trip is:

$$\$143,000 \div 20,500 = \$6.98.$$

According to the results of the lift-user survey presented earlier (see Table 4-5), the average linked trip requires 1.4 links (0.4 transfers).^{*} Therefore, the operating cost per linked trip would be:

$$\$6.98 \times 1.4 = \$9.77.$$

Capital cost can be added to the cost per trip by using an annual capital recovery factor. Metro staff has annualized capital cost using a discount rate of 10% and a life of 12 years. For the sake of comparability with another, recent SMD evaluation, annualization is figured here at 10% over 10 years, which results

^{*}A "linked trip" is a complete trip by a person, without regard to the number of transfers made to complete the trip. If a passenger transfers once, he or she has made two "unlinked trips," but only one "linked trip," consisting of two segments, or "links."

in an annual capital recovery factor of .163.* Using the \$1,040,000 capital cost derived in Section 6.3.1, annualized capital cost is about \$170,000. Then, operating plus capital cost per unlinked trip is:

$$(\$143,000 + \$170,000) \div 20,500 = \$15.27,$$

while the operating plus capital cost per linked trip is:

$$\$15.27 \times 1.4 = \$21.38.$$

In future years there will be some factors tending to increase the cost and some tending to decrease it. On the downward side, very little additional staff time will be needed with higher levels of service. In fact, the estimate of \$61,500 used here for the 163-bus level of service is based on current Metro experience with 259 accessible diesel buses and 16 electric trolley buses on 45 routes. However, Metro staff agreed that staff time is fairly independent of service level. In addition, it is possible that productivity (i.e., lift uses per vehicle) will increase due to: 1) increased use of all routes as a more and more complete network is provided, and 2) implementation of nine more trolley bus routes, which are among the most heavily used routes in the system.

On the upward side, there are still many low-productivity routes remaining to be implemented. Also, as more additions are made to the fleet, the price of the lifts will increase.** As the lifts get older, maintenance costs can be expected to increase. In the short run, it seems almost certain that the cost per trip will decrease.*** In the long run, considerably more analysis would be required to determine whether cost per trip is more likely to go up or down.

*A life of 12 years gives a capital recovery factor of .147.

**This might really be considered an effect of inflation rather than a cost of increased service. If costs in constant dollars are considered, this effect ought to be much reduced. On the other hand, lifts for trolley buses and articulated buses may actually be more expensive.

***Based on estimates by Metro for July 1981, the operating plus capital cost per unlinked trip is estimated at \$11.12. This includes \$61,500 in staff time, \$264,500 in annualized capital cost, and \$137,500 in repair cost per year. Annual ridership is estimated at 41,700 based on three lift-use counts at the current level of service.

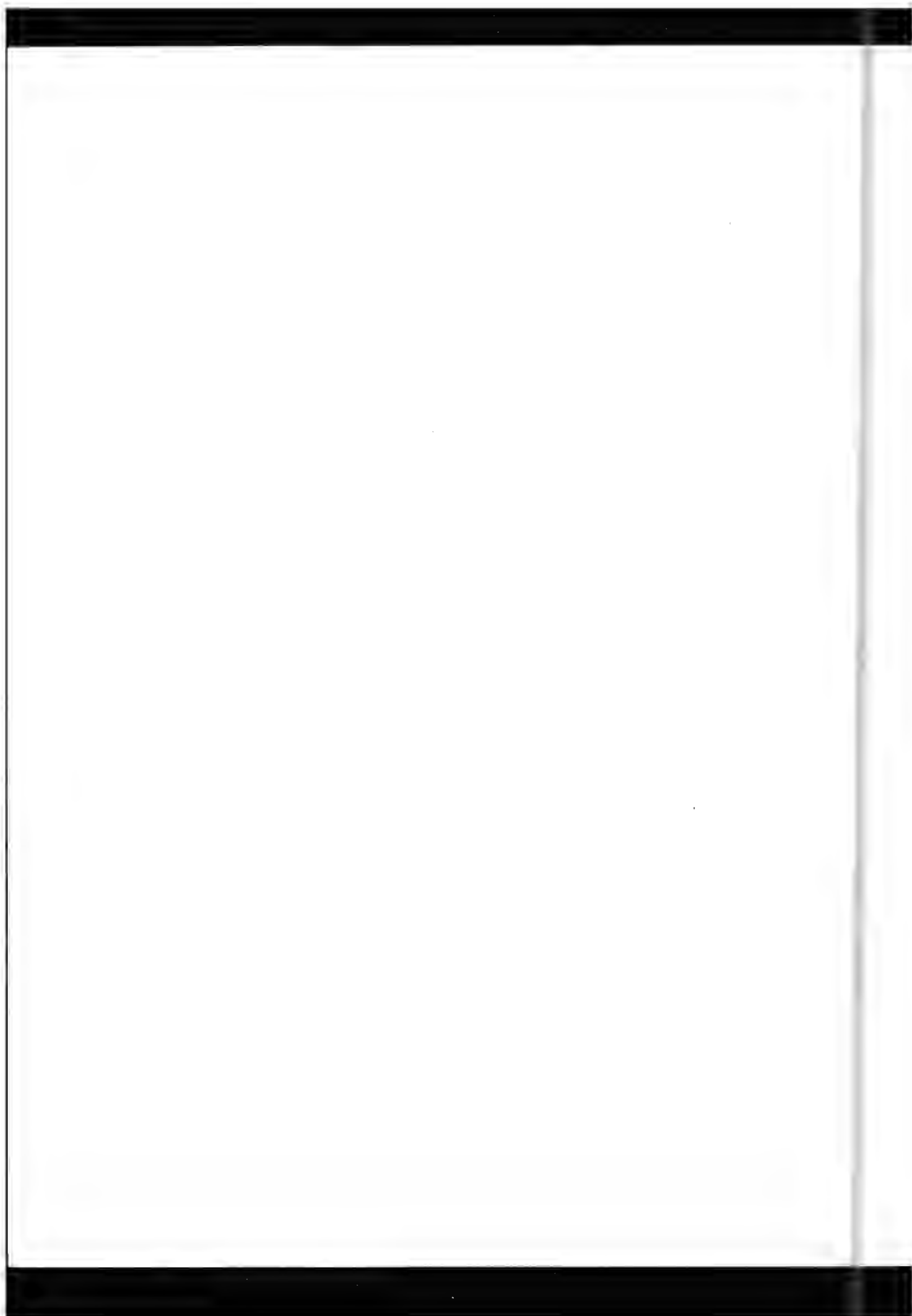

7. CONCLUSIONS

Based on the analysis presented in the foregoing chapters, this chapter attempts to answer some of the basic questions posed by Metro's experience with accessible service.

7.1 RIDERSHIP

Why has lift ridership in Seattle been several times greater than on any other system (with one, recent, possible exception)? The analysis of proportional lift use in Chapter 4 suggests that the reasons are mostly quite simple. At the time the study began, no other major transit operator had implemented accessible service as reliable and extensive as Seattle's. Comparable-sized programs had been implemented in Washington, D.C., St. Louis, Los Angeles and Connecticut. However, all have been plagued by difficulties providing reliable service. Other programs (and to some extent Connecticut's) have been on systems much smaller in size than Metro's, or with much lighter ridership in general. Small amounts of service (as in Champaign for example) are unlikely to generate high total lift use. Light general ridership (as in Orange County for example) indicates a service area which is hard to serve by transit or else a population which does not like to use transit. Both situations are likely to carry over to the handicapped population and result in light lift use.

Reliable service also appears to be a major reason for high proportional lift use (as opposed to total ridership) in Seattle. Several other factors also appear important, including good service planning and marketing, the strong support of the handicapped community for fixed-route accessibility, and a lack of any comparable competing accessible transportation. The key factors analyzed in this case study, which are discussed in the following sections, are equipment reliability, service reliability, and planning.

7.2 EQUIPMENT RELIABILITY

Chapter 6 showed that the Lift-U lifts used in Seattle have had a low failure rate. Unfortunately the limited scope of the study has not permitted us to find a definite reason for this low failure rate. Metro appears to have done an

excellent job of maintaining the lifts. They have received good warranty service from Lift-U, which is also located in Seattle. The Lift-U lift is of a fairly simple design, and built mostly of purchased rather than specially-manufactured parts. These features may make it more reliable or easier to maintain than other lifts, although there is no evidence available to confirm or deny such a hypothesis. The most straightforward explanation is that the passage of time and experimentation with various lift designs over the last several years has enabled Lift-U, as well as other lift manufacturers, to finally produce a more reliable product than was used in earlier implementations. This hypothesis is supported by reports of relative reliability from transit operators who have recent installations of lifts from most of the major manufacturers.

7.3 SERVICE RELIABILITY

Chapter 5 documented the relative reliability of the Seattle lift service from users' point of view. One reason for reliable service is the mechanical reliability just discussed. Another reason is the maintenance of an adequate spares ratio, exceeding 10% at each operating base (raised to 15% as of January 1981). Still another reason, which may be inferred although it was not documented, is that Metro's dispatchers have been particularly conscientious in seeing to it that designated accessible runs are served by functioning accessible buses. Their ability to do so was enhanced by the conservative service planning discussed below.

7.4 PLANNING AND IMPLEMENTATION

Several features of the planning and implementation process stand out. These include: the degree of involvement by the handicapped community; the involvement of drivers through the Driver Task Force; a very low-key, informational marketing effort; a policy of designating only as much service as accessible as could be reliably provided; the amount of attention given to working out detailed policies and procedures; and a focus on high-ridership routes. All except the last contributed to good relations among lift users, drivers and management. The policy of concentrating on high-ridership routes and serving special housing for the handicapped probably contributed directly to high levels of lift use.

7.5 COST EFFECTIVENESS

The cost-per trip figures calculated in Chapter 6 are very low compared to similar calculations for other accessible services. The operating cost per linked trip of \$9.77 is comparable to costs for some paratransit systems. The major reason for the observed level of cost effectiveness is the high ridership already discussed. The mechanical reliability and ease of repair of the lift have also kept down costs.

7.6 IMPLICATIONS FOR OTHER TRANSIT SYSTEMS

7.6.1 Ridership

If several conditions are met, other transit systems might achieve lift use levels similar to Seattle's. These conditions include: extensive accessible service, high general ridership on accessible routes, reliable service, careful service planning, strong support among the handicapped for fixed-route accessibility, and a lack of widespread alternative accessible transportation. Systems with lighter ridership than Metro might still expect lift use as a percentage of ridership on accessible routes in the same range as Metro's if the remaining conditions are met. This hypothesis is supported by the fact that early counts of lift-users riding AC Transit buses exceed early Metro counts (with about the same amount of service offered) and that the Champaign-Urbana Mass Transit District reports lift use which is higher as proportion of total ridership on the accessible routes than is Metro's.

Nevertheless, there is the possibility that unique or unknown factors, undetectable in an evaluation of the type conducted, contributed to the level of lift use in Seattle. Consequently, even if the accessible service was planned and executed in a similar fashion, some cities might experience much lower lift use both in total and proportional terms. By the same token, the possibility cannot be ruled out that some cities might experience even higher lift use than Seattle.

7.6.2 Mechanical Reliability

Regarding the mechanical reliability of the lift, it is possible that Metro's close proximity to and long-established working relationship with Lift-U contributed to the success of Metro's maintenance program. There is no reason to think, though, that other operators would not receive good support from Lift-U. Moreover, recent models of most other lifts are also reported to be very reliable. Of course, any transit operator which is having difficulty maintaining its regular, non-accessible fleet may anticipate similar problems with accessible equipment.

It is conceivable that the lack of a hard winter in Seattle has made maintenance easier, not only for the lifts but for equipment in general. Nevertheless, many transit systems manage to keep their buses running during hard winters. Recent reports of reliable operation from Champaign-Urbana, Illinois seem to confirm that a lift can be mechanically reliable during a hard winter as well.

7.6.3 Service Reliability

Given mechanically reliable equipment, there seems to be no reason why any other transit operator could not provide reliable service, given that an operator is presently able to provide reliable service to the general population. Unfortunately, in times of financial difficulties, many operators are finding it difficult to keep service dependable. If an adequate spares ratio cannot be maintained, or if accessible vehicles are likely to be forced to cover for inoperable, non-accessible ones, then service reliability will suffer. The best response is probably to implement no more accessible service than can be consistently and dependably provided, given a realistic assessment of each operator's situation.

7.6.4 Planning and Implementation

Metro's approach to planning and implementation worked well in Seattle. Should it be copied in other cities? Some elements of the process might be unnecessarily elaborate, especially in smaller cities, and some might not work in a different situation. The elements which appear most transferable are involvement and a good relationship with the handicapped community, conservatism in the quantity of service initially provided, and a focus on high-ridership routes. Some operators of heavily-used systems might feel that accessibility on their highest ridership routes would be impractical. Nevertheless, it is almost certainly an important part of a plan to provide service to the greatest number who need accessible service. Metro was able to serve at least one known major concentration of wheelchair users, which happened to be located on a very high-ridership route. In another site, such a concentration might occur on a less heavily-used route. A body such as the Driver Task Force might be unnecessary in some small operations, and might not be feasible in a property where driver-management relations are already difficult. Precise working out of procedures might be unnecessarily formal in small systems. In larger systems it appears a good idea if practical.

APPENDIX A
ACCESSIBLE SERVICE TRAINING OUTLINE



ACCESSIBLE SERVICE TRAINING

TYPE: Video Cassette/ Demonstration

Time: Approximately 1½ hours

Three operators per training session.

Introduction

- a. Attendance
- b. Explain scope of training
- c. Hand Out
 1. Operator's Manual for the Flyer Coach/
Accessible Service

Classroom Training

- a. Video-Cassette on Accessible Service, depicting handicapped passenger using the Lift.

Familiarization

- a. Practical experience on a coach at an Accessible Bus Zone.
 1. Includes role playing. Operators use wheelchairs to board, tie-down and deboard coach. Promotes accurate empathy for physical challenges facing wheelchair passengers. Provides practice for giving verbal instructions and appropriate use of outside speaker system.

Summary

- a. Accessible Service Public Relations.

LIFT-U - LIFT OPERATION

DESCRIPTION

The lift is track mounted and when in "STOW" position, part of the platform is the bottom step. By positioning selector switches, the operator can deploy the lift, raise or lower the platform and stow the lift. Normally, hydraulic power diverted from the power steering system powers the lift.

The wheelchair platform is attached to the open end of the frame with four parallel chain synchronized arms that can rotate sufficiently to raise the platform to the coach floor level, or to ground surface level as desired. A SAFETY GATE is provided on the platform to prevent a wheelchair from rolling off.

LIFT OPERATION

1. Set emergency brake
2. Put coach in neutral
3. Activate 4-way flashers
4. Activate lift-power switch

TO DEBOARD PASSENGERS

- a. Press UP switch
- b. Passenger on ramp
- c. Press DOWN switch
- d. Passenger deboards
- e. Press both STOW switches

TO BOARD PASSENGERS

- a. Press DOWN switch
 - b. Passenger on ramp
 - c. Press UP switch
 - d. Passenger enters coach
 - e. Press both STOW switches
5. De-activate lift-power switch

NOTE: Activating 4-way (hazard) flashers first will prevent unnecessary delay to following coaches.

ACCESSIBLE SERVICE

INTRODUCTION

- A. Why accessible coaches and service.
 1. Metro Transit guidelines require that all transit service will be accessible to the disabled community. All coaches are to be lift equipped.
 2. Metro is a public agency charged with providing transportation to King County residents. It desires to serve all residents where reasonably possible.
 3. The disabled population in King County is more than 63,000. A part of those people are currently using transit.
- B. What is the plan for accessible service?
 1. Implementation of accessible service will be completed by the gradual phasing-in of particular routes and runs.
 2. Operator requirements and responsibilities, in part, are intended to be used as foundation data for the establishment of future policies and procedures.
 3. During the formative stage, an operator task force represents operators to formulate operator feedback and recommendations regarding accessible service.
 4. Operator support systems are in place at the time actual service is implemented.
 - a. Outreach program to educate mobility impaired passengers in use of accessible coaches.
 - b. Complete and thorough briefings of all service supervisors and coordinator personnel.
 - c. Customer Assistance Office personnel ready to provide assistance in dealing with difficult passenger situations and/or passengers.

Accessible service is new to transit and the public. Operator input on use of the equipment, any additional schedule requirements, the performance of the lift and the passenger reactions will be invaluable in making the system-wide implementation very smooth.

An Operator Task Force was formed and is responsible for gathering information.

The Customer Assistance Office has a Lift Bulletin for the public which is mailed or given out on request.

STOPPING NEAR THE CURB

CAUTION: The accessible lift extends out approximately five (5) feet from the coach when deployed.

When loading or unloading passengers, the operator should position the coach at a distance from the curb that will permit patrons to make a normal step between coach and the curb.

- a) If, for any reason, the coach is unable to stop near the curb, the stop should be made far enough away so that the passenger would be required to step onto the street when boarding or alighting.
- b) In rural areas where there are no curbs and there is insufficient room to pull the coach completely off the roadway, passenger stops are to be made with the coach remaining in the traffic lane.

TYPES OF WHEELCHAIRS

There may be a wide variety of wheelchair types which will board the coach.

1. Types of wheelchairs.
 - a. Large motorized.
 - b. Custom-made chairs with different size wheels and frames.
 - c. Chairs with permanently reclining backs.
 - d. Standard size wheelchairs with modifications.
 - e. Motorized chairs with oversize wheels and spokes.
 - f. Scooter - "Steno Chair on a scooter."
 - g. Cart - "Battery powered flat cart."

SEAT BELTS

1. A seat belt is not a tie-down device and should not be used as a tie-down for a chair.
2. The seat belt is optional. However, people in wheelchairs who need seatbelts usually have them.

TIE-DOWN DEVICES

1. Clamp & cargo straps.

The chairs must be secured on both sides using the combination of the crab-claw clamp and a red cargo strap, or both red cargo straps if not using the claw clamp.

WHO CAN USE THE LIFT

Anyone who for some reason cannot, or should not, climb bus steps may use the lift:

1. People confined to wheelchairs.
2. People requiring the assistance of walkers, crutches, canes, etc.
3. People who walk unassisted, but cannot exert themselves or bend their legs enough to climb steps

(e.g., because of a heart condition or severe arthritis).

Some disabled passengers routinely travel with attendants to assist them. If you are operating an accessible route and run you may allow the disabled passenger to have the attendant accompany them while riding on the lift. This applies to wheelchair passengers as well as disabled standees. This is the only instance that two people will be allowed to ride the lift together. Caution the attendant about the limited doorway head clearance. Passengers accompanied by attendants are still required to use the tie-down devices on their wheelchairs.

*Note: The lift is not to be cycled for grocery carts, strollers or any other similar items.

LIFT USE

The only time the lift should be used is:

1. If the operator's route and run has been designed "Accessible."
2. The operator is qualified on the lift operation.
3. The intending passenger is in a designated accessible zone.

PASSENGERS IN WHEELCHAIRS

Metro offers three types of service for passengers in wheelchairs who wish to ride:

1. Non-lift and non-tie-down equipped coaches, (i.e., 200's, 500's, 700's, and 800's). A passenger in a wheelchair may ride these coaches only if the passenger can board and de-board the coach by him/herself or with a companion's assistance. They must be able to transfer to a seat and collapse their chair.
2. Tie-down equipped coaches, (i.e., AMG's and Artic's). These coaches are equipped with one crab-claw clamp under the seat opposite or behind the rear door. A passenger in a wheelchair may ride these coaches only if the passenger can board and de-board the coach by him/herself or with a companion's assistance. They may either secure their chair in the claw-clamp and remain in their chair for the ride or transfer to a seat and collapse the chair.
3. Lift and tie-down equipped coaches, (i.e., Flyer coaches and AMG trolleys). A passenger in a wheelchair may board a lift-equipped coach that is assigned to a designated accessible route/run. The passenger must be able to:
 - a. Board the lift platform by him/herself or with a companion's assistance.
 - b. Prevent the chair from rolling while on the moving platform by him/herself or with a companion's assistance.
 - c. Maneuver into the tie-down areas by him/herself or with a companion's assistance.

The operator must check the securement of tie-downs and assist the passenger, if necessary, before moving the coach.

ZONE DESIGNATION

Buz zones on accessible routes are being marked with a reflectorized wheelchair emblem if that zone is accessible. This emblem, wrapped around the post right beneath the sign, will replace the blue paint marks previously used to identify an accessible zone.

The downtown zones served by accessible routes are marked with the accessible emblem on the sign posts. This is to end the ongoing confusion about "free ride" area zones all being accessible zones.

If you are operating an accessible route/run in the CBD, whenever possible pull to the head of the zone and use 4-way flashers when deploying the lift. This will allow coaches behind you to continue on schedule as you board or deboard passengers in wheelchairs.



These stickers sometimes disappear, so if you notice one missing, from a sign post that is supposed to have one, please send an incident/Service Report to facilities maintenance at Dearborn and identify the stop.

People in wheelchairs are not as visible as people standing around them. Please keep an eye open for intending wheelchair passengers. The disabled public has been informed in the newsletter to be watching for their bus. They were informed that the second or third bus in line is not required to make a second stop at the head of the zone.

OPERATOR RESPONSIBILITY

Though accessible coaches may be operating on non-designated routes and runs, the lifts are not to be used (regardless of the operator's qualifications or the passenger's requests). Operators receiving passenger complaints for refusing to deploy the lift on non-designated routes and runs will not have them entered into their records, but may be subject to RDA's for operating the lifts when not properly authorized.

REPORT PROCEDURE

All incident/Service Reports and accident reports pertaining to accessible service should be so designated by writing "Accessible Service" on the report.

PASSENGER COMPLAINTS

If an operator is in compliance with Metro Policy, the operator does not have to justify accessible service procedure to a complaining passenger. The complaining passenger should be politely referred to the Customer Assistance Office.

STUDENT OPERATORS

Until such time when the Instruction Department can train student operators in wheelchair lift operation, the student operators are not required to operate the lift when training on a run featuring accessible service. If a student is operating when the lift needs to be used, the regular operator should take over from the beginning to the end of the lift operation.

BUS FARE

Fare for lift passengers is the same as for regular passengers (aids or attendants pay regular fare):

1. 15¢ with Reduced Fare Permit.
2. 50¢ full fare, one-zone.
3. 75¢ full fare, two-zone.

ROUTE AND SCHEDULE INFORMATION

Route and schedule information is updated regularly in "The Lift Bulletin," which is available in the Customer Assistance Office, 821 Second Avenue, Seattle, WA, 98104. Metro bus timetables have symbols next to each

trip that is equipped with a lift. Specific information can be obtained from Metro Information (447-4800).

OVERLOADS

In the event of an overload condition on the coach and intending passengers, including passengers in wheelchairs, are being passed up, the coordinator is notified according to standard procedures for reporting an overload.

WHEELCHAIR OVERLOAD

If the overload condition applies only to the fact that both tie-down areas are occupied by passengers in wheelchairs who must remain there, the lift will be cycled only if the intending wheelchair passenger can transfer to a seat and collapse his/her chair or one of the wheelchair passengers on the coach will transfer to a regular seat and collapse his/her chair.

STANDARD OVERLOAD PROCEDURE

DO NOT jeopardize yourself, your passengers, motorists or pedestrians by carrying a load that you cannot safely handle.

When your coach is overloaded and additional riders cannot be accommodated safely, operators are to immediately call the Coordinator giving your route, run number, direction, location and number of standing passengers.

Please note that you should not board so many passengers that your view to the front doorway is blocked. Passengers should be advised not to stand or sit in the stairwells when the coach is in motion. It is important that you are able to see the right side mirror.

You should make every effort to see that passengers move to the rear of the coach so as many people as possible can be accommodated.

LIFT MALFUNCTIONS

Lift malfunctions are to be reported to the coordinator by the operator. An accessible designated coach must be replaced by another accessible coach if a coach change is at all possible. The operator must inform intending lift passengers of the malfunction, but must not board these passengers, unless as per current policy for collapsible wheelchairs. Wheelchair passenger stranded by a lift malfunction may be deboarded by use of the emergency ramps only. (Ramps will not be used to board wheelchair passengers.)

You may check your lift prior to service if desired but it is not required.

BOARDING PROCEDURES

Boarding wheelchair passengers, the operator should:

1. Allow other passengers to get on or off first.
2. Ask if person has used lift before.
3. Caution wheelchair passengers and other passengers to stay 5 feet clear of front door so they are clear of lift while cycling. Caution wheelchair passenger not to board lift until operator says it is safe to do so. (Lift extends 4 feet from side of coach when fully deployed.)
4. Direct wheelchair onto lift and make sure wheelchair is situated in proper position. It is preferred that the wheelchair back onto the lift to minimize the maneuvering required to position the wheelchair for securing once it is on the coach (especially with a crowded bus), but this is not mandatory. Other factors (limited visibility, limited mobility, etc.) may necessitate loading in a "front-first" position - operator should use discretion. Caution passenger, once on the lift, to set brake and grasp handrail, watching clearance between hands on handrail and doors as lift operates. Make sure safety gate is functioning to prevent wheelchair from rolling off lift.

NOTE:

Wheelchair passengers may board the lift forwards or backwards. It is not mandatory that they back onto the lift.

5. Cycle lift up. Assist wheelchair passenger, if necessary, to manage sharp turn upon entering coach.
6. The operator will secure coach by setting parking brake, then will have to leave the seat to:
 - a. Make sure wheelchair is secured before moving coach.
 - b. Assist wheelchair passenger with tie-down devices (clamp, cargo straps and seat belt), if passenger needs help. These devices must be used by passenger; an unsecured wheelchair on a moving coach is a safety hazard to other passengers as well as the wheelchair passenger. The operator may not move the coach until the wheelchair is properly secured. Operator should be sure to attach cargo strap hooks to the frame of the chair, not the wheels. Attaching straps to the wheels can be dangerous and puts undue strain on the chair.

NOTE:

Operators are not required to:

1. Leave the coach to assist passengers.
2. Lift disabled passengers and/or chairs in any manner (except in extreme emergencies).
3. Deploy lift for other than needing wheelchair passengers and standees.
4. Deploy lift when overload condition exists.
7. If wheelchair jump seats are occupied by other passengers, the operator is to politely ask them to move to other seats so that the wheelchair passenger may be secured. Coach may not be moved until chair is secured.
8. Operator should ask where passenger wants off so coach can be positioned to cycle the lift at that stop.

Some wheelchair passengers do not have good verbal skills and may have difficulty communicating their desired stop to the operator. It has been suggested to those people that they have their destination on a card to show the operator in addition to watching carefully for their stop.

STANDEES

When standees need to use the lift, the operator should:

1. Direct the standee to stand on painted footprints and grasp handrail in center area.
2. After lift has cycled up, caution passenger to duck head upon entering coach.

NOTE:

If the lift is particularly jerky, in cycling, providing an unstable platform for standee while being raised or lowered, the operator is to avoid using the lift for standees. In this event, the passenger is to be advised that the lift on this particular coach is not safe for standing use and will receive mechanical attention. The operator must B.O. the coach upon returning to the base.

When operating lift equipped coaches at night (or at any time when headlights are used) the lift tends to be jerky because of the increased electrical drain.

DEBOARDING PROCEDURE

1. Check to see if wheelchair passenger needs assistance in releasing tie-down devices.
2. Allow other passengers to get off first and, when the lift is in position, have wheelchair passenger move onto lift.
3. Make sure wheelchair passenger stays clear of cycling lift. The operator may have to give guiding assistance to get chair around sharp corner and onto lift. Make sure chair is positioned appropriately (facing out door, not backing in, is preferred for disembarking) and brakes are set before cycling lift down.
4. Move wheelchair passenger onto the lift platform, as passenger sets brakes and grasp handrails. If standing, have passenger move to the outer edge of the platform (watching doorway clearance), stand on the footprints, and grasp handrails.
5. Caution any intending passengers on the street to stay clear of lift as it is being extended.
6. Stow the lift before allowing other passengers to board.

If you are operating an accessible run and are unable to board an intending wheelchair passenger due to lift failure or incorrect equipment, call the coordinator immediately.

The coordinator will then inform you as to what action is being taken so you can inform the intending passenger.

In the event of not being able to board a wheelchair passenger due to an overload, the coordinator should be notified as usual in the case of overloads and the intending wheelchair passenger will have to wait for the next regularly scheduled accessible trip.

EMERGENCY PROCEDURES FOR ACCESSIBLE SERVICE

EMERGENCY RAMPS

In the event of lift breakdowns, stranded wheelchair passengers will be deboarded by means of the wooden emergency ramps located in the maintenance departments of all five operating bases. Ramps will not be used to board lift passengers; these passengers must wait until the breakdown has been corrected or until the next designated accessible service is available.

GENERAL EMERGENCY PROCEDURE

In the event an accessible coach is involved in an accident and there is no imminent danger resulting, do not remove wheelchair passengers. If the wheelchair passenger is injured, wait for Aid Car Personnel to treat and remove the individual.

EXTREME EMERGENCY/WHEELCHAIR EVACUATION

The operator should remove the wheelchair passenger from a coach, only if it is more dangerous to leave the passenger on the coach. Examples of such situations are where the coach is in imminent danger of:

1. Fire
2. Explosion
3. Bomb threat
4. Traffic hazard, or
5. Physical peril (i.e., coach perched on a cliff).

In these situations, the operator should deboard the wheelchair passenger using the following methods (listed in order of preference):

1. Use the lift as per regular instructions. If not at a curb or in a curb lane, the operator should have another person stand on the right side of the coach to halt any traffic which may attempt to pass on that side of the coach. Accompany the wheelchair passenger to a secure location.
2. Use the Emergency Ramp as per regular instructions. The ramp should be considered only when time is available for its delivery and use.
3. Lift the wheelchair passenger (while still in the chair), with the help of others and carry off the bus through the front door. Use the back door if the front is inaccessible. Always carry the wheelchair off backwards.
4. Lift the passenger (without the chair) with the help of others and carry off the bus through the front door. Use the back door if the front is inaccessible.
5. Lift the impaired passenger, with the help of others, and evacuate through one of the emergency windows.

WHEELCHAIR EVACUATION/NO HELP AVAILABLE

In the event an operator is alone and unable to enlist the help of others, evacuation of a wheelchair passenger is best accomplished by:

1. Checking with the passenger for the best way to carry him/her and proceeding accordingly.
2. If the passenger is unconscious, the best carry method is to drape the passenger's arms over the operator's shoulders and, with the passenger facing the operator's back, carry him/her to safety.

EMERGENCY EVACUATION SUMMATION

1. Use Lift
2. Use Emergency Ramp
3. Lift Wheelchair Through Doors
4. Lift Passenger Through Doors

5. Lift Passenger Through Window
6. Carry Passenger Off On Back. (When operator alone and no help available.)

WHEELCHAIR LIFT/EMERGENCY RAMPS

Should a lift break down, emergency ramps for deboarding "stranded" wheelchair passengers are located in the maintenance departments at each of the five operating bases. District supervisors dispatched by the coordinators will bring the emergency ramps.

ACCESSIBLE SERVICE
PUBLIC RELATIONS

Obstacles to mobility impaired people. Courage is required of disabled people to deal with and overcome various obstacles. Being sensitive can provide positive assistance.

A. Physical obstacles.

1. Stairs, curbs, access to buildings, steep streets, street surfaces, width of doorways, getting to and from bus zones, etc. Sometimes passengers have gone to great lengths just to get to the bus stop.

B. Attitudes that create obstacles.

1. Lack of awareness.
2. Embarrassment.
 - a. People who are threatened by being in the company of disabled people.
3. Overly helpful people who damage self-esteem of disabled person.
4. Unhelpful people who stand by while disabled person struggles. A lack of sensitivity to the circumstances of others.
5. People who ignore the needs and limitations of disabled persons.
6. Persons who are deliberately resentful about disabled people.

C. When you are in doubt about whether a person needs help - ask. Do not assume, allow the person to choose if he/she desires help and the type of help needed.

D. Things that influence the attitudes of disabled and nondisabled people.

1. Positive experiences, negative experiences.
2. Fear
 - a. of failure

- b. of rejection
- c. of being physically hurt
- 3. Involvement
 - a. Association can develop understanding.
 - b. People dislike or fear that about which they have no knowledge or familiarity.
 - c. Indirect involvement (reading, being told about) usually produces minimum investment.
 - d. Direct involvement (first hand contact or experience) usually produces maximum investment.
- 4. Time - getting used to a new idea.

Dealing with the Public.

- A. Lack of information can create confusion and no cooperation.
 - 1. Telling passengers what is happening and why.
 - 2. Politely referring any complaining passenger to Metro CAO. The operator does not have to justify accessible service to complaintant, refer person to CAO.
- B. The adjustment period.
 - 1. Everything new seems to take longer.
 - 2. Passenger's attention will be directed to lift usage because of newness.
 - a. New experience seeing and using lift.
 - b. New experience riding with wheelchair passengers.
 - 3. Most disabled persons do not have riding experience. They will need to develop good riding habits by consistent treatment and instructions from operators.
 - 4. Most regular passengers do not have riding experience with disabled passengers. They

will need consistent encouragement and instructions from operators.

5. Setting and reinforcing limits regarding acceptable and nonacceptable behavior when riding the bus. Equal expectations of all passengers, disabled or not.

C. Getting the jump seats vacated.

1. Constructive ways to make a request.
 - a. Avoiding demands.
 - b. Polite requests.
 - c. Remaining neutral in your request. ("The company would like people to make these seats available, etc.")
2. In the event of a refusal.
 - a. Coach does not move until wheelchair is secured in proper place.
 - b. Last resort is removal by service supervisor.

D. Passenger confrontations.

1. The need to be alert to any antagonistic interchange between passengers concerning the disabled passengers.
 - a. Intervening before situation escalates.
 - b. Overt hostility may be initiated by anyone, disabled or nondisabled.
2. Refusing to do that which you deem unsafe.
 - a. Use of "I" message in refusing. ("I'm sorry. For your safety the company does not allow me to do _____ etc.")
 - b. Explain company regulations which govern the limits of an operator's responsibility.
 - c. Be alerted to sympathetic phrases used by the passengers including the disabled.

FLYER COACH WHEELCHAIR LIFT TROUBLE SHOOTING

Problem: Lift won't deploy. (Check rear door interlock)

Solution: Let engine run four minutes to build up hydraulic pressure (any time after coach has been shut down), then attempt to operate lift again.

Recheck lift operation procedure, checking in particular the following steps:

1. Transmission is in neutral.
2. Lift power switch has been activated.

Check hydraulic fluid level. A simple preliminary check can be made by turning the steering wheel to see if the power steering is working (both the steering and the lift operate on the same hydraulic system). To accurately check the fluid level, one must open the rear engine compartment and "eyeball" the fluid level through the glass window in the steering/lift reservoir behind the right tail light. Check for hydraulic fluid on the ground under reservoir or under the lift.

Check for physical damage to lift mechanism under front of coach.

CAUTION: Lift to ground clearance is only 7 inches on operator's side of empty coach and 7½ inches on front door side!

Problem: Lift gets stuck during initial deployment or stowing.

- Solution:**
1. Manually push doors aside if this is causing the jamming.
 2. Jiggle and shake technique:
Manually grasp handrails and jiggle lift. Ramp sometimes sticks in stowing tracks/channels under coach and must physically be freed. This operation may take two people: one to operate control switches, the other to jiggle and shake the lift.

3. If lift is stuck in "down" position and won't stow, then move to "Up" position and recycle.
4. If lift is stuck in "up" position and won't stow, then move to "down" position and recycle.
5. Check hydraulic system (details above).
6. Manually stow lift (if not seriously jammed) by turning bolt on underside of coach, beneath operator. Call coordinator for assistance.

Problem: Safety gate won't drop.

- Solution:
1. Step on gate.
 2. Check safety gate hinge for gravel or other debris jamming the hinge.
 3. Wiggle "dog ears" at corners of lift ramp to free ramp of jamming debris.

Lift malfunction - Disembarking.

1. Make sure wheelchair passenger is secure, explain difficulty and that you are calling for assistance.
 - a. Do not lift passenger and/or wheelchair yourself. This may result in injury to you or passenger.
2. Call coordinator, report malfunction, request portable ramp to be dispatched; receive further instruction regarding coach change.
3. Inform your passengers about delay, explain what is happening. You may give transfers if passengers elect to take another bus.

Lift malfunction - Boarding.

1. Boarding - inform intending passenger that lift is malfunctioning and that you are requesting assistance.

- a. Do not lift passenger and/or wheelchair yourself. This may result in injury to you or passenger.
2. Call coordinator, report malfunction and receive further instructions regarding coach change.
3. Inform your passengers if coach is to be held up. You may offer transfers.

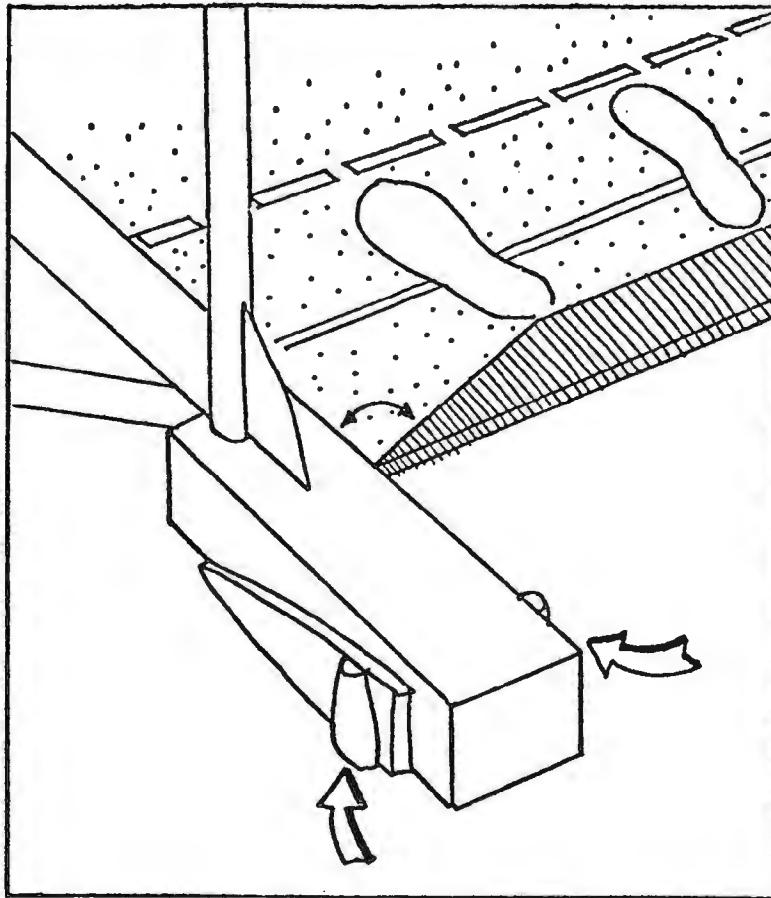

"Dog Ears" (at corners of lift ramp) mechanically drop safety gate when tripped by edges of channel guides (stowing tracks) during stowing. May jam with debris and need to be wiggled free

SAFETY GATE OPERATION

In order to improve the reliability of the safety gate, Lift-U is changing the circuit for the gate. There have been problems with the present gate switch located on the bottom of the platform, and with the actuator wire for this switch. The actuator wire and the switch are both being removed.

The new circuit will include the "below stow" and "slack chain" switches, so the safety gate will not lower until two conditions are met:

1. The platform must be below the "stow" level.
2. Main chain must be "slack."

After the platform is on the ground surface, hold the "Down" switch for two (2) seconds before releasing the switch. This will satisfy Condition #2 and the safety gate will then lower.

Coaches are being retrofitted by Lift-U on an ongoing basis. This new safety gate circuit will eliminate the gate's tendency to malfunction at various stages of the cycle.

Please continue to write B.O. slips on any lift malfunctions so maintenance and Lift-U can correct problems with the lifts and compile accurate "lift-malfunctions" records.

When cycling the lift to the "up" position, release the "up" button as soon as the lift is all the way up and even with the floor of the bus. Keeping the button on longer than necessary causes a build up of pressure on the chain. Relief valves are now being installed to alleviate this pressure problem. When the relief valve engages it sometimes makes a "chattering" noise, this is not a sign of a malfunction.

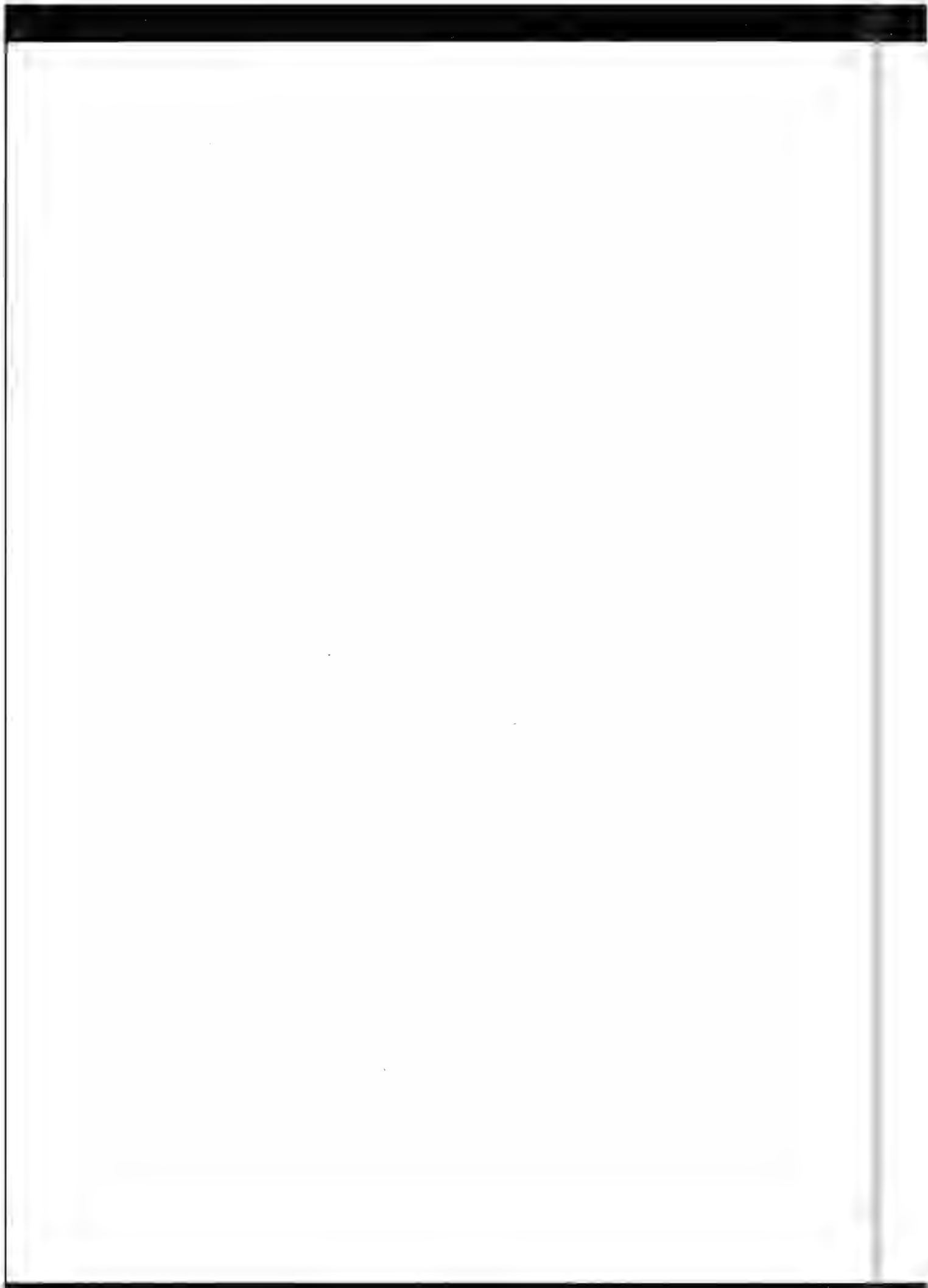

APPENDIX B
DRIVER SURVEY

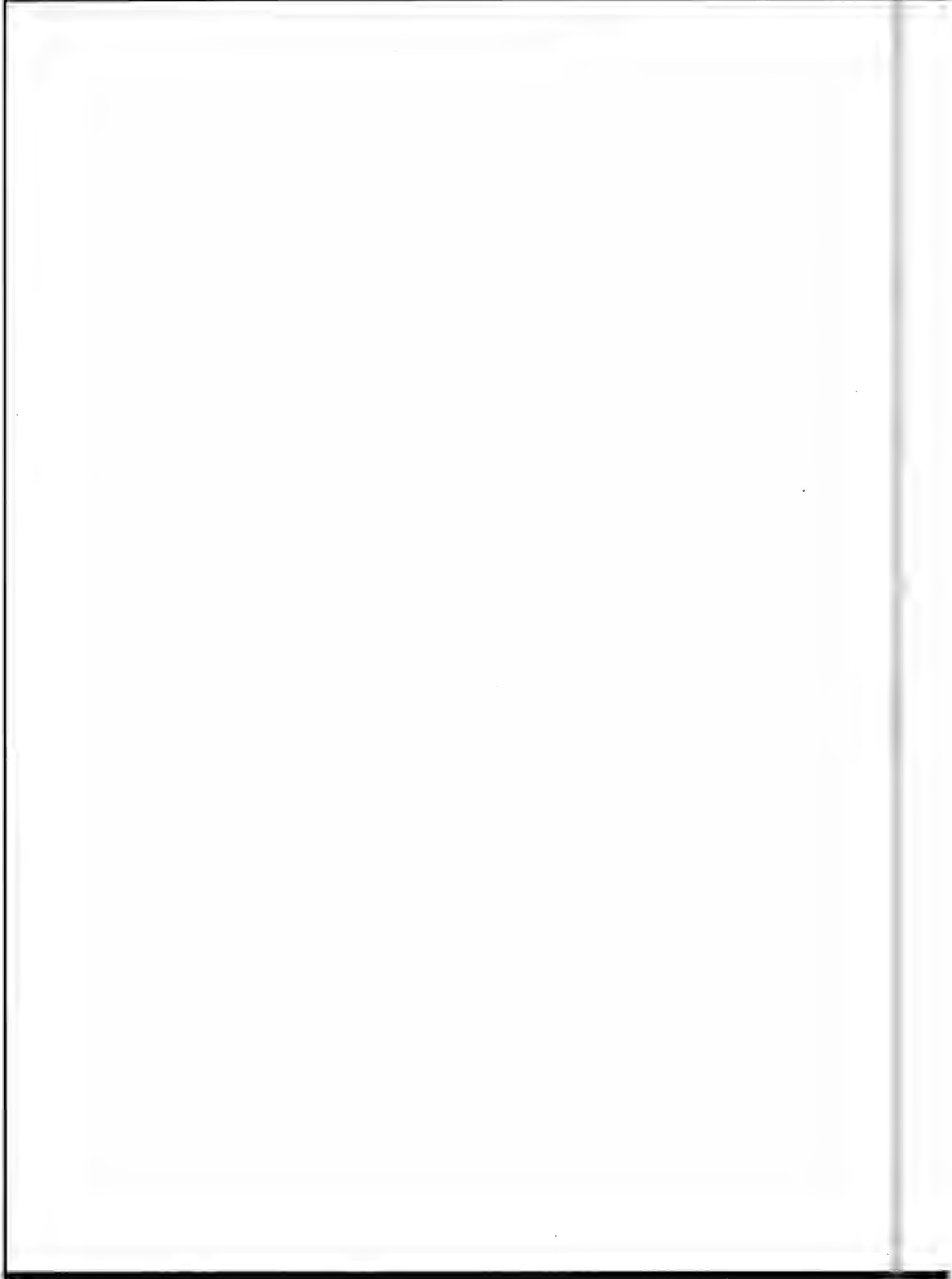

DRIVER SURVEY -- ACCESSIBLE SERVICE

THIS SURVEY WILL BE USED BY AN INDEPENDENT EVALUATOR TO EVALUATE METRO'S ACCESSIBLE SERVICE. PLEASE PLACE THIS SURVEY IN THE ATTACHED ENVELOPE AND MAIL WHEN COMPLETED. NO STAMP IS NECESSARY.

| | | |
|---|---|---|
| 1 | 2 | 3 |
|---|---|---|

PLEASE CHECK APPROPRIATE BOXES.

1. HAVE YOU EVER DRIVEN ON A DESIGNATED ACCESSIBLE RUN? ___(4)
 1 YES 2 NO → (IF THE ANSWER IS NO, YOU NEED NOT FILL OUT THE REST OF THIS SURVEY.)

2. WHAT IS YOUR DRIVER CLASSIFICATION? ___(5)
 1 REGULAR DRIVER 2 EXTRA BOARD DRIVER 3 PART-TIME DRIVER

3. PLEASE RATE THE LIFT IN THE FOLLOWING AREAS:
 (Fill in each blank with a 1, 2, 3, or 4; 1=Excellent, 2=Good, 3=Fair, 4=Poor)
 - A. SAFETY FOR WHEELCHAIR USERS _____ ___(6)
 - B. SAFETY FOR USE BY NON-WHEELCHAIR HANDICAPPED _____ ___(7)
 - C. MECHANICAL RELIABILITY _____ ___(8)
 - D. EASE OF OPERATION BY DRIVER _____ ___(9)

4. HOW OFTEN DO WHEELCHAIR USERS NEED ASSISTANCE TO TIEDOWN? ___(10)
 1 NEVER
 2 1/4 OF THE TIME
 3 1/2 OF THE TIME
 4 3/4 OF THE TIME
 5 ALWAYS

5. HOW DO WHEELCHAIR WHEELS FIT INTO THE WHEEL LOCKS? (Please check one) ___(11)
 1 MOST WHEELS FIT IN EASILY
 2 MANY FIT, BUT WITH DIFFICULTY
 3 VERY FEW FIT.

6. TO LOAD A WHEELCHAIR PASSENGER (DEPLOYMENT OF LIFT TO LEAVING ACCESSIBLE ZONE) TAKES ME: ___(12)
 1 1-3 MINUTES 3 6-10 MINUTES
 2 4-5 MINUTES 4 MORE THAN 10 MINUTES

7. EFFECT OF LIFT USAGE ON SCHEDULE:
 - A. LITTLE OR NO IMPACT ON SCHEDULE (EASY TO COMPENSATE) 1 YES 2 NO ___(13)
 - B. IF I USE THE LIFT I AM BEHIND SCHEDULE FOR THE REMAINDER OF THAT TRIP ONLY 1 YES 2 NO ___(14)
 - C. IF I USE THE LIFT I AM BEHIND SCHEDULE FOR THAT TRIP AND SUBSEQUENT TRIPS 1 YES 2 NO ___(15)

8. AVERAGE USE OF THE LIFT IS:

- 1 LESS THAN ONCE A WEEK
- 2 LESS THAN ONCE A DAY
- 3 ONCE A DAY
- 4 TWICE A DAY
- 5 THREE TIMES A DAY
- 6 FOUR OR MORE TIMES A DAY

9. PLEASE RATE THE FOLLOWING: (1=NEVER; 2=SELDOM; 3=OFTEN; 4=ALWAYS)
NON-DISABLED PASSENGERS...

- A. COMPLAIN ABOUT THE LIFT _____
- B. MOVE READILY OUT OF FOLDUP SEATS WHEN NECESSARY _____
- C. USUALLY HELP THE WHEELCHAIR PASSENGERS _____
- D. STANDING PASSENGERS MOVE READILY OUT OF THE WAY FOR
WHEELCHAIR PASSENGERS _____

10. DO YOU FEEL THAT THE DRIVER TASK FORCE ON ACCESSIBLE SERVICE HAS BEEN BENEFICIAL? _____

- 1 YES
- 2 NO

11. DO YOU FEEL THAT THE LIFT OPERATION & SENSITIVITY TRAINING WAS:

- 1 EXCELLENT
- 2 GOOD
- 3 FAIR
- 4 POOR

12. WHAT ACCESSIBLE ROUTE OR ROUTES DO YOU REGULARLY DRIVE?

ROUTE _____
ROUTE _____
ROUTE _____

13. PLEASE WRITE IN ANY COMMENTS OR GENERAL FEELINGS ABOUT METRO ACCESSIBLE SERVICE.

THANK YOU FOR YOUR HELP.

(6)

(7)

(8)

(9)

(10)

(11)

(12)

(23)

(26)

(29)

(32)

(33)

APPENDIX C
LIFT BULLETIN

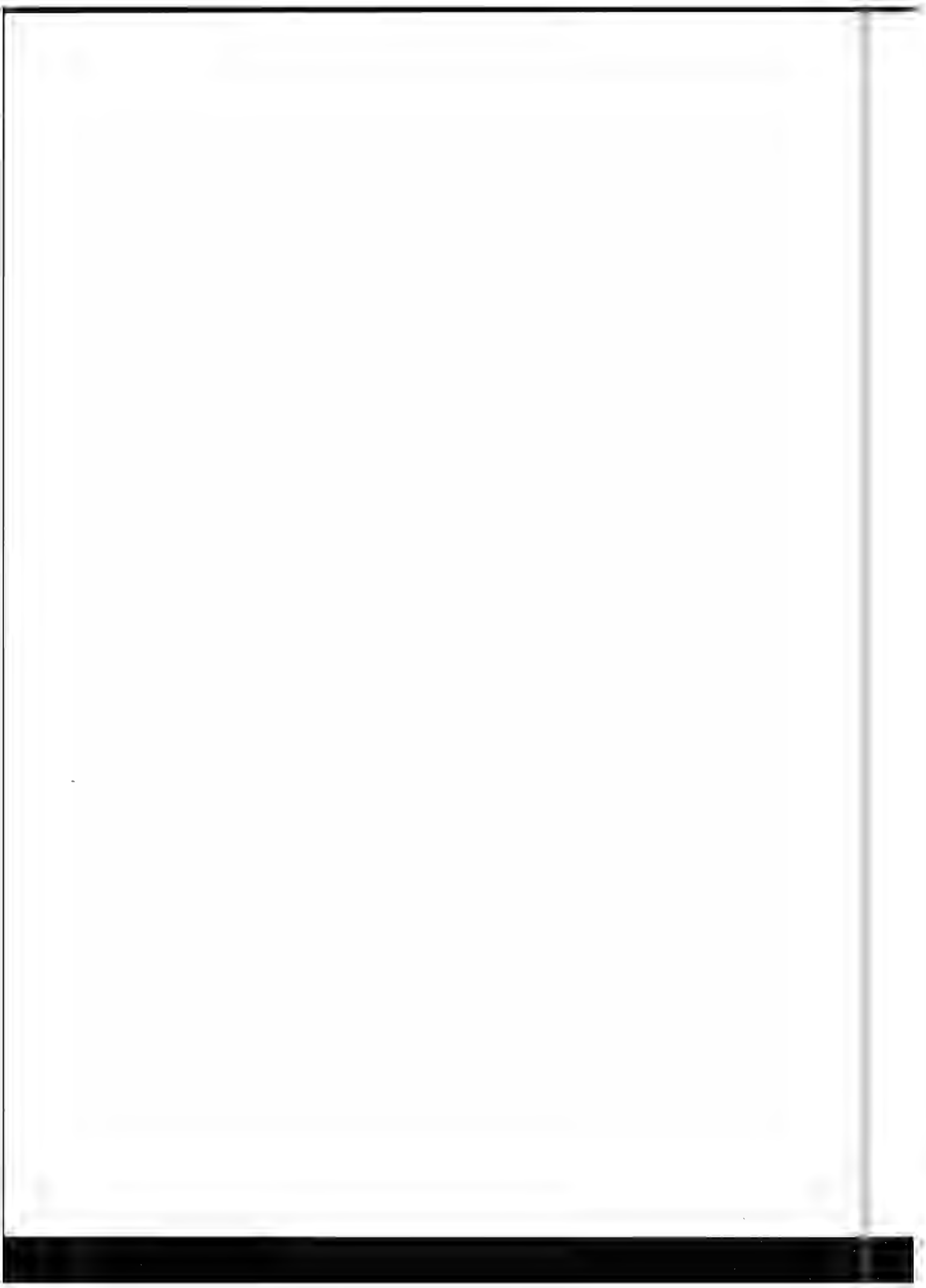



Exchange Bldg. • 821 Second Ave., Seattle, Washington 98104

May 21, 1980

Dear Rider:

On May 24, 1980, Metro will offer accessible service on a total of 24 routes. Approximately hourly service will be available on these routes: 5, 6, 7, 15, 16, 17, 18, 19, 22, 24, 30, 31, 39, 55, 72, 107, 130, 132, 136, 150, 155, 253, 305 and 317. In addition to adding route 155 to the list of accessible routes, two more special routes will offer accessible service: Seattle Parks Special and the Bel-Hop shuttle bus serving downtown Bellevue.

Service changes happen three times a year. At these times new timetables are issued to reflect any changes in schedules or routes. Please be sure you have a current timetable. Timetables are printed with accessible trip information and are available at the Metro Customer Assistance Office, Second Avenue and Marion Street. They are also available at: Northgate Mall, University of Washington Bookstore, University of Washington HUB (on campus), Downtown Library, Boeing Plant II Cafeteria, King County Courthouse, King County Administration Building, Ferry Terminal, Amtrak, Southcenter Mall, Sea-First Bank Building (3rd Avenue and 4th Avenue entrances), City Light, Pier 70, Pacific Northwest Bell, Seattle Convention and Visitors Bureau, and the Municipal Building. Timetables for routes in your area are also available at most 7-11 stores, all Bartell Drugstores and all libraries. Timetables can be mailed on request by phoning 447-4800.

Service Additions - At service change times we endeavor to add more accessible routes or trips; however, due to equipment shortages and service over-extension in some areas, Metro is not able to increase accessible service as quickly as desired. Trolley service is planned to start sometime in 1981. At that time, as trolley buses are equipped with lifts, accessible trolley service will start. The trolley routes will provide good service to Capitol Hill, major hospitals and Queen Anne hill. We will keep you posted on trolley service.

Bus Stops - Knowing the location of the closest accessible bus stop makes your bus travel easier, so lists of these stops are available. The stops marked "yes" are accessible and stops marked "no" on the lists did not meet accessibility criteria at this time. Please plan to use an accessible stop so the driver can safely pick you up or let you off. Wheelchair access emblems are wrapped around the sign post beneath the sign to make it easier for you and your driver to recognize these stops. Bus stops in the downtown area for accessible routes are also marked with an emblem. If a bus stop or route you wish to use is not accessible, please call 447-4824 to see if we can place that stop or route on the "to be accessible" list.

When waiting for a bus at a downtown stop, be watching for your bus since two or three buses pull into a zone at one time. The driver may not be able to see you if she/he is the second or third bus back especially if there are a lot of people waiting at the stop. The second or third bus back is not required to stop again at the head of the zone for safety reasons. As the first, then second, and third bus leave the bus stop, a second stop by one of these may cause rear-end collisions. Second stops also prevent the next group of buses from entering the zone, interrupt the flow of traffic and make it difficult for buses to keep their time schedules. Please be watching for your bus so the driver can safely and quickly pick you up and get you to your destination on time.

- OVER -

Communicating with the Driver - If your verbal skills are not good and you are concerned about communicating your destination to your driver, a card with your desired stop printed or typed on it will help you and your driver communicate. Show this card to your driver when you get on so she/he will be aware of your destination. Drivers have a lot of things to do and watch for as they drive so you must watch for your stop and signal in time for the bus to safely stop at the bus stop. The card is just a helpful way to communicate your destination and it will ease any discomfort your drivers may have if they can't understand you. When drivers are trained on the lift usage, they are informed that some people may use a card to communicate destinations. The best way to describe your stop is to state the street the bus is on, the closest cross-street and even a "landmark." (Example: Aurora Avenue N. and N. 85th Street by the Jack-In-The-Box.) The reason a "landmark" helps is that often your driver may not be familiar with the area and "landmarks" are quickly recognized.

Lift Procedures - If you are able to and prefer to transfer from your chair onto a seat, please do so; however, your chair must then be folded and held next to you. When riding the bus in your chair, you must use the devices provided for securing your chair. Seatbelts are optional.

During peak riding hours, some of these routes are very busy and often the buses are crowded. In the event a bus is so crowded that intending passengers are passed up, you will have to wait for the next scheduled lift bus, so whenever possible, especially during the rush hours, give yourself plenty of time to get to your destination. If you can schedule your bus rides for non-peak times, we would recommend you do so.

In order to help accessible bus service run smoothly and safely for everyone it is important that passengers in wheelchairs riding Metro follow the passenger guidelines for accessible service. If you have difficulty boarding the lift platform or you are unable to prevent your chair from rolling while on the platform, you must bring a friend to assist you. The driver is not required to help you get on or off the platform. Zones that are not accessible have failed at this time to meet the criteria for accessibility. Please do not wait at a non-accessible zone or request to de-board at a non-accessible zone. Zone lists are available at the Customer Assistance Office to help you plan your trips.

If you have questions about accessible service, please call Gretchen Roosevelt at 447-5808 (or write to Metro Customer Assistance Office, M/S 76, 821 Second Avenue, Seattle, Washington 98104). Your comments will help us to continue making improvements in our accessible service. Please call 447-4800 for schedule information or assistance after 5:00 p.m.

Thank you for riding.

Very truly yours,



B. J. Carol, Acting Manager
Marketing and Customer Information Division

BJC:grt

SPECIFIC SERVICE INFORMATION - May 24, 1980 Service Change

Route 7 As you may notice on the summary of accessible trips, weekend accessible service on route 7 has been increased considerably. This is a heavily used route and the additional accessible trips have been needed.

Route 31 During the summer there will be construction work at Veterans' Hospital which will prevent the route 31 from looping through the hospital grounds. If you plan to travel on this route be aware that you will not be able to board or de-board at the hospital entrance bus zone. As soon as construction is complete and service is back on regular route, we will let you know.

Route 72 Due to schedule and through-route revisions on route 72, the number of weekday accessible trips has been reduced.

Bel-Hop The Bel-Hop Shuttle is a free bus, lift-equipped, which serves the downtown Bellevue district. Timetables for this route are also available.

Seattle Parks Special

The Seattle Parks Special route operates Sundays and holidays to major Seattle parks from Memorial Day through Labor Day. The north route stops at ten parks and several museums. The south route stops at about nine parks and some beaches in West Seattle. Timetables with maps are available and the buses on the Parks Special routes are lift-equipped.

GR:nt

NUMBER OF SCHEDULED ACCESSIBLE TRIPS
SUMMARY

| Route | SEPTEMBER 79 | | | FEBRUARY 80 | | | MAY 80 | | | SEPTEMBER 80 | | |
|---------|------------------------|----|----|------------------------|-----|-----|------------------------|----------------|-----|------------------------|--|--|
| | <u>weekday/Sat/Sun</u> | | | <u>weekday/Sat/Sun</u> | | | <u>weekday/Sat/Sun</u> | | | <u>weekday/Sat/Sun</u> | | |
| 5 | | | | 94 | 72 | 67 | 92 | 64 | 73 | | | |
| 6 | 37 | 41 | 41 | 77 | 76 | 76 | 77 | 76 | 76 | | | |
| 7 | | | | 102 | 68 | 48 | 107 | 103 | 81 | | | |
| 15 | | | | 68 | 54 | 54 | 73 | 55 | 56 | | | |
| 16 | 37 | 42 | 42 | 73 | 77 | 77 | 74 | 77 | 77 | | | |
| 17 | | | | 46 | 47 | 45 | 41 | 43 | 43 | | | |
| 18 | | | | 77 | 78 | 79 | 80 | 83 | 79 | | | |
| 19 | | | | 32 | 37 | 38 | 32 | 38 | 39 | | | |
| 22 | | | | 51 | 51 | 48 | 51 | 51 | 48 | | | |
| 24 | | | | 35 | 38 | 38 | 37 | 39 | 39 | | | |
| 30 | | | | 55 | 78 | 76 | 76 | 66 | 64 | | | |
| 31 | | | | 27 | 25 | 0 | 31/39-43 | 25 | 0 | | | |
| 55 | | | | 56 | 63 | 78 | 66 | 63 | 72 | | | |
| 72 | | | | 49 | 46 | 34 | 27 | 53 | 41 | | | |
| 107 | | | | 22 | 0 | 0 | 30 | 0 | 0 | | | |
| 130/132 | | | | 49 | 48 | 46 | 130 17 132 28 | 20 18 24 26 | | | | |
| 136 | | | | 36 | 37 | 37 | 39 | 38 | 38 | | | |
| 150 | | | | 37 | 34 | 35 | 38 | 33 | 32 | | | |
| 155 | | | | | | | 33 | 20 | 12 | | | |
| 253 | | | | 17 | 0 | 0 | 29 | 0 | 0 | | | |
| 305 | | | | 34 | 30 | 29 | 34 | 29 | 30 | | | |
| 317 | | | | 23 | 18 | 18 | 23 | 18 | 18 | | | |
| TOTALS | 74 | 83 | 83 | 1060 | 977 | 923 | 1147 | 1018 | 962 | | | |



Municipality of Metropolitan Seattle

Exchange Bldg. • 821 Second Ave., Seattle, Washington 98104

June 18, 1980

**University District/
Downtown Seattle**
Local Service via Eastlake Ave E
Includes Routes 8, 22, 71, 72, 73, & 305

Route
72 Serving
Lake City, Maple Leaf,
University District,
Downtown Seattle

Route Map & Timetable



Dear Riders:

The current University District/Down-
town Seattle timetable is incorrectly
marked for Accessible trips on Route 72.
Please refer to the Route 72 timetable
for correct information concerning
accessible trips, with the exception of
the Saturday trip from 3rd and Main at
5:29 p.m. (which is not an accessible
trip, but was marked as one).

In addition to Gray Top Cab Co., Farwest
Cab Co. now has a lift equipped van-cab.
Both cab companies dispatch their vans
through their regular service phone
number and both companies accept Metro
Taxi Scrip.

Very truly yours,

B. J. Carol
Project Manager
Accessible Service Program

BJC:grq



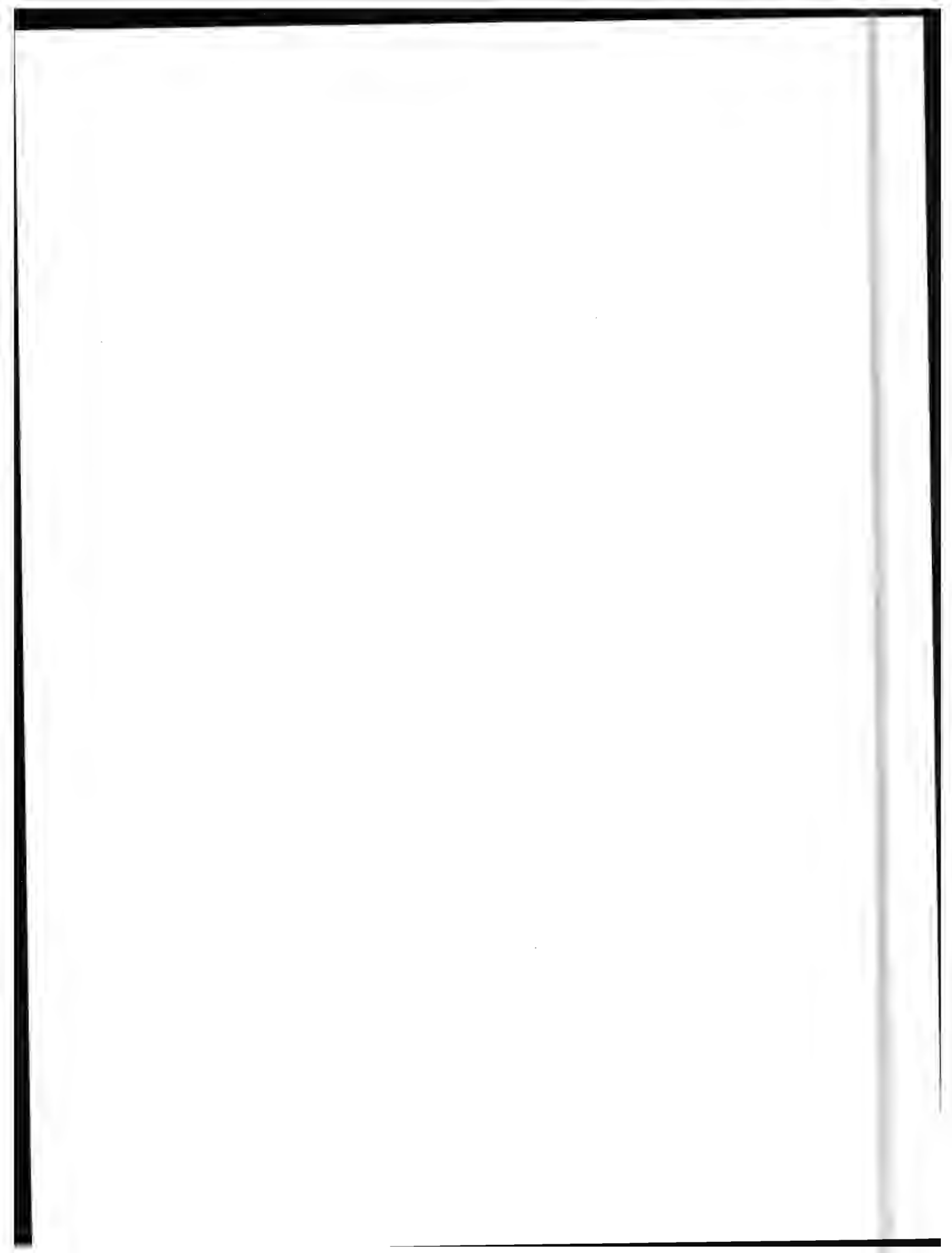

APPENDIX D
LIFT-USER SURVEY

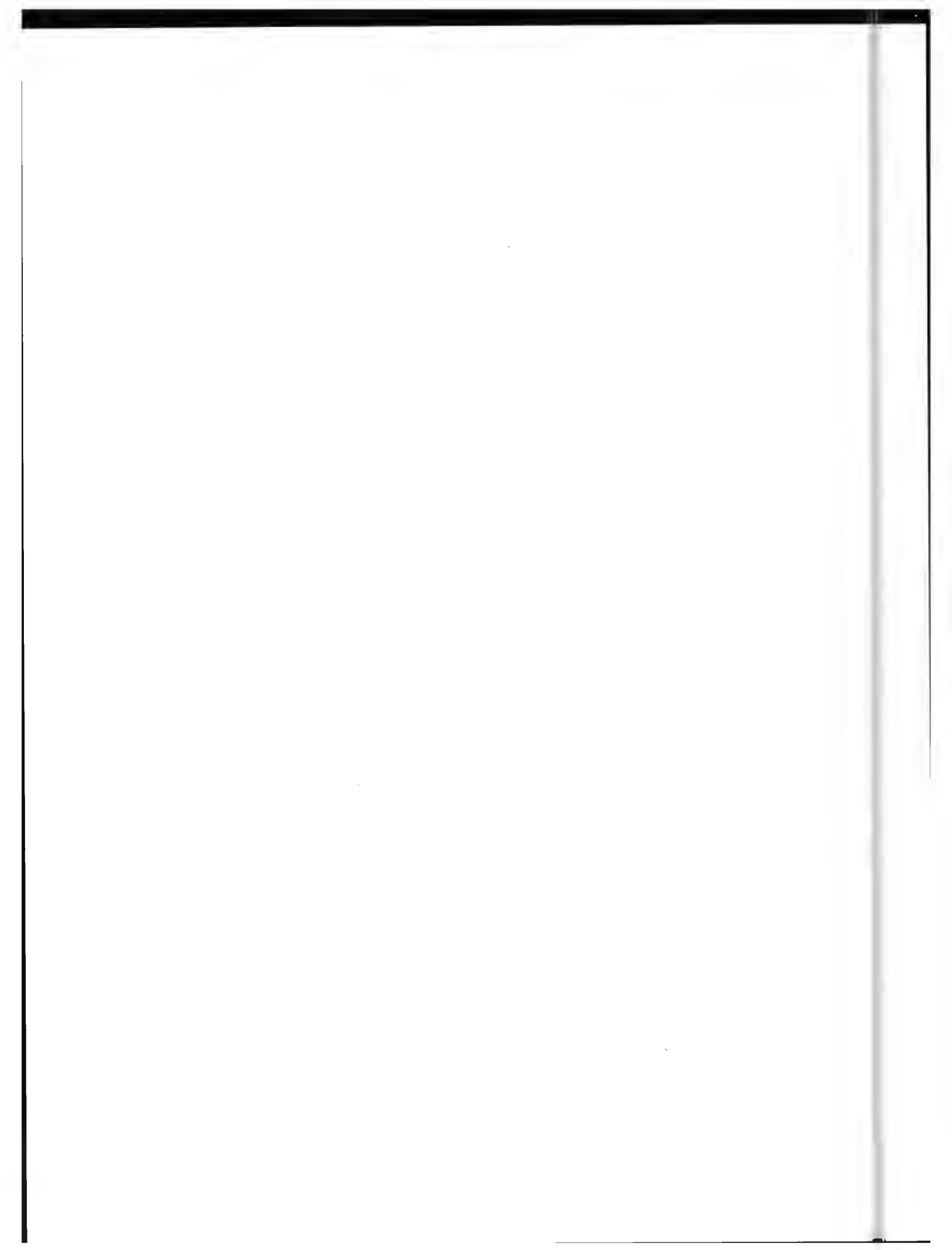

LIFT USER SURVEY MAIL BACK CARD

METRO LIFT USER SURVEY



PLEASE HELP METRO SERVE YOU BETTER BY COMPLETING THIS CARD. (IF YOU HAVE ALREADY COMPLETED ONE CARD, YOU DO NOT NEED TO COMPLETE ANOTHER ONE.) WHEN YOU ARE FINISHED, JUST PUT IT IN THE MAIL. NO STAMP IS NECESSARY. THANK YOU FOR YOUR HELP!

1. ABOUT HOW MANY ONE-WAY RIDES DO YOU TAKE ON METRO BUSES IN AN AVERAGE WEEK?

- ___ LESS THAN ONE ___ 3 TO 4 ___ 7 TO 8
___ 1 TO 2 ___ 5 TO 6 ___ 9 TO 10 ___ MORE THAN 10

2. DO YOU RIDE THE BUS TO...

- ___ WORK? ___ SHOP? ___ RECREATION OR TO VISIT PEOPLE?
___ SCHOOL? ___ CONDUCT PERSONAL BUSINESS?
___ OTHER? ___ MEDICAL OR REHABILITATION APPOINTMENTS?

3. WHAT AIDS DO YOU USE WHEN YOU RIDE THE BUS?

- ___ MANUAL WHEELCHAIR ___ CANE ___ NONE
___ ELECTRIC WHEELCHAIR ___ CRUTCHES ___ OTHER:
___ WALKER ___ BRACES

4. HOW FAR DO YOU GO FROM YOUR HOME TO AN ACCESSIBLE BUS STOP?

- ___ LESS THAN ONE BLOCK ___ ABOUT TWO BLOCKS
___ ABOUT ONE BLOCK ___ THREE OR MORE BLOCKS

5. AGE: ___ UNDER 20 ___ 20-34 ___ 35-54 ___ 55-64 ___ 65+

6. DO YOU EVER TRANSFER TO ANOTHER BUS? ___ YES ___ NO

WE WOULD LIKE TO FIND OUT MORE ABOUT YOUR EXPERIENCES USING METRO BUSES. IF YOU WOULD BE WILLING TO TALK TO ONE OF OUR METRO SURVEY TEAM, PLEASE FILL IN YOUR PHONE NUMBER:

PHONE NO. _____ WHO SHOULD WE ASK FOR? _____

IF YOU DO NOT HAVE A PHONE OR WOULD PREFER A PERSONAL VISIT, PLEASE FILL IN YOUR HOME ADDRESS. WE WILL CONTACT YOU AND MAKE AN APPOINTMENT TO SEE YOU.

ADDRESS: _____
NO. STREET APT. OR ROOM NO. CITY

BEST TIME FOR US TO CALL OR MAKE AN APPOINTMENT TO VISIT:

- DAY OF WEEK: ___ THURSDAY TIME OF DAY:
___ MONDAY ___ FRIDAY ___ MORNING
___ TUESDAY ___ SATURDAY ___ AFTERNOON
___ WEDNESDAY ___ SUNDAY ___ EVENING

Thank You. Just Put This Card in the Mail. No Stamp is Needed.

SURVEY OF SEATTLE METRO LIFT USERS

Respondent's Name _____

Respondent's Phone: _____

Respondent's Address: _____

CALL RECORD

| Date | Time | Outcome |
|------|------|---------|
| | | |
| | | |
| | | |
| | | |
| | | |
| | | |
| | | |

(ASK FOR RESPONDENT BY NAME IF SUPPLIED, AND READ INTRODUCTION TO RESPONDENT.)

INTRODUCTION: Hello, my name is _____, and I'm calling for Metro transit. We would like to ask you about your use of the lift on accessible Metro buses. Have you ever used the lift to get on or off the bus? ___ Yes (*GO TO Q.1*) ___ No.

IF NO, Do you have, or would you have trouble using bus steps?

1. Yes. 2. No (*TERMINATE INTERVIEW*).



IF YES, We would like to ask you more about your needs and problems in using buses when we conduct our non-user survey in about three weeks. What would be a good time for us to call back?

- | | |
|---------------|-------------|
| ___ Morning | ___ Weekday |
| ___ Afternoon | ___ Weekend |
| ___ Evening | |

Thank you, those are all the questions I have at this time.
(*TERMINATE INTERVIEW.*)

MAILING LIST VERSION

1. First, I'd like to ask you about the number of one-way trips you take on Metro buses in a typical week. When we say one-way trip, we mean that if you go to visit a friend on the bus and then come back on the bus, that would be two trips. Is that clear?

About how many one-way rides do you take on Metro buses in a typical week?

- | | |
|----------------|-----------------|
| 1. Less than 1 | 5. 7 to 8 |
| 2. 1 to 2 | 6. 9 to 10 |
| 3. 3 to 4 | 7. More than 10 |
| 4. 5 to 6 | |

2. Do you ride the bus to:

- | | |
|----------------|--|
| 1. Work? | 4. Recreation or to visit people? |
| 2. Shop? | 5. Conduct personal business? |
| 3. School? | 6. Medical or rehabilitation appointments? |
| 7. Other _____ | |

3. What aids do you use when you ride the bus?

1. Manual wheelchair
2. Electric wheelchair
3. Walker
4. Cane
5. Crutches
6. Braces
7. None
8. Other _____

4. How far do you go from your home to an accessible bus stop?

1. Less than one block
2. About one block
3. About two blocks
4. Three or more blocks

5. Are you...

1. Under 20 years old?
2. 20-34?
3. 35-54?
4. 55-64?
5. 65 or older?

6. Do you ever transfer to another bus?

1. Yes
2. No

MAILING LIST VERSION

7. I'd like to ask for some more detail about your trips on Metro Transit. (REPEAT FOLLOWING SEQUENCE FOR EACH PURPOSE CHECKED ON Q2.)

| | <u>Purpose</u> | <u>Trips per wk</u> | <u>Trips per mo</u> | <u>Xfers</u> | <u>2 xfers</u> |
|---|----------------|---------------------|---------------------|--------------|----------------|
| In a typical week, how many one-way trips do you make on Metro transit in order to (READ PURPOSE FROM Q2). (IF RESPONDENT MAKES FEWER TRIPS THAN ONE A WEEK, REPEAT SAYING "MONTH" INSTEAD OF "WEEK".) How many of these trips involve a transfer? Do any of them involve two or more transfers? How many? | a) _____ | _____ | _____ | _____ | _____ |
| | b) _____ | _____ | _____ | _____ | _____ |
| | c) _____ | _____ | _____ | _____ | _____ |
| | d) _____ | _____ | _____ | _____ | _____ |
| | e) _____ | _____ | _____ | _____ | _____ |
| | f) _____ | _____ | _____ | _____ | _____ |
| | g) _____ | _____ | _____ | _____ | _____ |

- 8a. You said that you use a* (READ AID FROM Q.3) when you ride the bus. Do you always use a (REPEAT AID) when outside the house?

1. Yes 2. No

- IF NO, b. What aids do you use when outside the house if you are not going to ride the bus?

1. Manual Wheelchair 5. Braces
 2. Electric Wheelchair 6. Cane
 3. Walker 7. Other: _____
 4. Crutches 8. None

9. How do you usually get from your home to the bus stop?

1. Walk 4. Get ride
 2. Wheel 5. Taxi
 3. Drive 6. Other: _____

10. About how long ago did you start riding the lift-buses? _____

- 11a. Do you plan to keep using the lift-buses?

1. Yes 2. No 3. Not sure

- b. IF NO, Why is that? _____

12. How many blocks can you go by yourself...

(a) ... in good weather? _____
 (b) ... in bad weather? _____

* (IF CHECKED "NONE" IN Q.3) You said you do not use any aid when you ride the bus. Do you never use any aids when outside the house? 1. Never use aid (GO TO Q9) 2. Sometimes use aid (GO TO Q8b).

BUS CARD VERSION

SURVEY OF SEATTLE METRO LIFT USERS

Respondent's Name _____

Respondent's Phone: _____

Respondent's Address: _____

CALL RECORD

| Date | Time | Outcome |
|------|------|---------|
| | | |
| | | |
| | | |
| | | |
| | | |

(ASK FOR RESPONDENT BY NAME IF SUPPLIED, AND READ INTRODUCTION TO RESPONDENT. IF NO NAME, USE ALTERNATE VERSION OF INTRODUCTION WITH PERSON ANSWERING.)

INTRODUCTION: Hello, my name is _____, and I'm calling for Metro Transit. You (a member of your household) recently sent in a card from a survey of people using Metro's new lift-equipped buses. You (they) said you (they) would be willing to answer a few more questions if we called (came to visit). Can you talk with me now? (Is that person home?)

(REPEAT INTRO TO RESPONDENT, IF NECESSARY)

First, I'd like to check over some of the information I have from the card you sent in. Let me clarify that this survey is concerned with people who use the lift on Metro's accessible buses. Have you used the lift to get on or off the bus? ___ Yes *(CONTINUE THE INTERVIEW)* ___ No *(CORDIALLY TERMINATE THE INTERVIEW)*. The first question was about the number of one-way rides you take on Metro buses in a typical week. When we say one-way trip, we mean that if you go to visit a friend on the bus and then come back on the bus, that would be two trips. Is that clear? Now, according to the card, you said you take *(NUMBER FROM CARD)* one-way rides in a typical week. Is that right? *(CORRECT ANSWER ON CARD IF NECESSARY.)*

BUS CARD VERSION

7. I'd like to ask for some more detail about your trips on Metro Transit. (REPEAT FOLLOWING SEQUENCE FOR EACH PURPOSE CHECKED ON CARD.)

| | Purpose | Trips per wk | Trips per mo | Xfers | 2 xfers |
|--|---------|-----------------|-----------------|-------|---------|
| In a typical week, how many one-way trips do you make on Metro transit in order to (READ PURPOSE FROM CARD). (IF RESPONDENT MAKES FEWER TRIPS THAN ONE A WEEK, REPEAT SAYING "MONTH" INSTEAD OF "WEEK".) How many of these trips involve a transfer? Do any of them involve two or more transfers? How many? | a) | _____ | _____ | _____ | _____ |
| | b) | _____ | _____ | _____ | _____ |
| | c) | _____ | _____ | _____ | _____ |
| | d) | _____ | _____ | _____ | _____ |
| | e) | _____ | _____ | _____ | _____ |
| | f) | _____ | _____ | _____ | _____ |
| | g) | _____ | _____ | _____ | _____ |

8a. You said that you use a * (READ AID FROM Q.3) when you ride the bus. Do you always use a (REPEAT AID) when outside the house?

1. Yes (GO TO Q9) 2. No

IF NO, b. What aids do you use when outside the house if you are not going to ride the bus?

- | | |
|------------------------|-----------------|
| 1. Manual Wheelchair | 5. Braces |
| 2. Electric Wheelchair | 6. Cane |
| 3. Walker | 7. Other: _____ |
| 4. Crutches | 8. None |

9. How do you usually get from your home to the bus stop?

- | | |
|----------|-----------------|
| 1. Walk | 4. Get ride |
| 2. Wheel | 5. Taxi |
| 3. Drive | 6. Other: _____ |

10. About how long ago did you start riding the lift-buses? _____

11a. Do you plan to keep using the lift-buses?

1. Yes 2. No 3. Not sure

b. IF NO, Why is that? _____

12. How many blocks can you go by yourself...

- (a) ... in good weather? _____
 (b) ... in bad weather? _____

*(IF CHECKED "NONE" IN Q.3) You said you do not use any aid when you ride the bus. Do you never use any aids when outside the house?

1. Never use aid (GO TO Q9) 2. Sometimes use aid (GO TO Q8b).

13. What type of housing do you live in?

1. Private house or apartment
2. Special housing for the handicapped
3. Nursing home or other type of institution
4. Other _____

14a. Do you have a driver's license? 1. Yes 2. No → (GO TO Q.15)

b. IF YES, Do you have a car or other vehicle available to you?

1. Yes, always
2. Yes, sometimes
3. Yes, occasionally
4. No. → (GO TO Q.15)

c. IF YES, About how often do you drive yourself places around town?

1. 4 or more times a week
2. 2 or 3 times a week
3. About once a week
4. 2 or 3 times a month
5. Once a month or less

d. Are there any trips that you now make by bus that you used to make driving yourself?

1. No. 2. Yes. →

Where did you go? (list) _____

Why did you switch to the bus for these trips? _____

15a. Do you get rides from friends or relatives?

1. Yes 2. No → (GO TO Q.16)

b. IF YES, About how often do you go places around town this way?

1. 4 or more times a week
2. 2 or 3 times a week
3. About once a week
4. 2 or 3 times a month
5. Once a month or less

c. Are there any trips that you now make by bus that you used to make by getting rides from friends?

1. No. 2. Yes. →

Where did you go? (list) _____

Why did you switch to the bus for these trips? _____

16a. Are you registered for Metro's taxi scrip discount program?

1. Yes 2. No 3. Don't know.

b. Do you ever use taxis?

1. Yes 2. No → (GO TO Q.17)

c. IF YES, About how often do you use taxis?

1. 4 or more times a week 4. 2 or 3 times a month
2. 2 or 3 times a week 5. Once a month or less
3. About once a week

d. How helpful and courteous do you find taxi drivers to be?

1. Very
2. Moderately
3. Not at all.

e. Are there any trips that you now make by bus that you used to make by taxi?

1. ___ No. 2. ___ Yes. →

Where did you go? (list) _____

Why did you switch to the bus for these trips? _____

17. How easy is it (would it be) for you to get in and out of a taxi?

1. Very easy
2. Moderately difficult
3. Very difficult
4. Impossible
5. Don't know.

18a. Do you use transportation provided by agencies such as United Cerebral Palsy or an accessible vans service, such as Far West Vans?

1. Yes. (Agency) 3. No. 4. ___ Don't know.
2. Yes. (Far West) | _____ | → (GO TO Q.19)

b. IF YES, About how often do you use this kind of transportation?

1. 4 or more times a week 4. 2 or 3 times a month
2. 2 or 3 times a week 5. Once a month or less
3. About once a week

c. Are there any trips that you now make by bus that you used to make by agency-provided transportation or accessible van?

1. ___ No. 2. ___ Yes. →

Where did you go? (list) _____

Why did you switch to the bus for these trips? _____

19. Are there any things you are able to do, or do more of, now that you can use Metro buses? What are those things?
(DO NOT READ CHOICES.)
1. Get a job or change jobs
 2. Apply for different jobs
 3. Be more independent of others
 4. Attend school or training
 5. Attend church
 6. Attend social events
 7. Attend entertainment facilities
 8. See more of family/friends
 9. Attend medical/health functions
 10. Utilize social services, such as day care, nutrition, etc.
 11. Other: _____

20a. Do you ride the bus on rainy days?

1. Yes. 2. No

b. IF NO, How do you make trips you would normally make on the bus?

1. Drive
2. Get ride
3. Taxi/van
4. Postpone trip
5. Don't go
6. Other: _____

21a. Has a Metro transit representative ever trained you in the proper use of the buses' lift feature?

1. Yes 2. No → (GO TO Q22a.)

b. IF YES, How useful was the training in helping you to use the lifts? (PROBE FOR COMMENTS)

22a. Have you ever wanted to get on a lift bus but been unable to?

1. Yes 2. No 3. Don't know → (GO TO Q. 23)

b. IF YES, Do you know why you were unable to board the bus?
(RECORD NUMBER TIMES IN SPACE AT LEFT)

- ___ 1. Scheduled lift bus trip did not have a lift on the vehicle.
How many times has this happened?
- ___ 2. Lift was inoperative. How many times has this happened?
- ___ 3. Driver refused to stop or allow me to board for
unknown reason. How many times has this happened?
- ___ 4. Cars parked in bus stop or other barriers prevented me
from reaching bus. How many times has this happened?
- ___ 5. Bus was too crowded. How many times has this happened?
- ___ 6. Unable to maneuver chair onto lift. How many times
has this happened?
- ___ 7. Wheelchair positions already occupied. How many times
has this happened?
- ___ 8. Other (specify): _____
- ___ 9. Don't know

c. IF YES TO 22a. After you were unable to get on the bus, what
did you do?

- 1. Did not make trip
- 2. Got a ride
- 3. Took a taxi
- 4. Waited for another bus.
- 5. Other: _____

23. Do you usually travel alone on the lift buses, or with a
friend or assistant.

- 1. Alone
- 2. Attended
- 3. Sometimes one, sometimes other

24. This part of the survey is to determine what other problems
you may have had with the lift buses. It works like this:
As I read each of the following items, I would like you to
tell me whether you view it as: a serious problem; a moderate
problem; or little or no problem. (FOR EACH "SERIOUS" OR
"MODERATE" RESPONSE, ASK "IN WHAT WAY HAS THIS BEEN A PROBLEM FOR YOU?")

| | SER* | MOD* | LIT. OR NO* | NATURE OF PROBLEM |
|--|------|------|----------------|-------------------|
| a. Getting to and from bus stop near your home | | | | |
| b. Getting to and from bus stop near the place you are going to | | | | |
| c. Waiting for the bus | | | | |
| d. Feeling safe while waiting | | | | |
| e. Getting onto the lift platform | | | | |
| f. WHEELCHAIR ONLY Immobilizing chair on the moving platform | | | | |
| g. Feeling safe while riding up and down | | | | |
| h. Paying your fare | | | | |
| i. Getting from the lift to your seat (or to the wheelchair position) | | | | |
| j. WHEELCHAIR ONLY Locking or strapping your chair into place on bus | | | | |
| k. WHEELCHAIR ONLY People sitting on the fold-down seats in the wheelchair area | | | | |
| l. Letting the driver know when you want to get off | | | | |
| m. Crowds in aisles | | | | |

*Serious, Moderate, Little or No

| 24. Cont. | SER* | MOD* | LIT. | NATURE OF PROBLEM |
|-------------------------------------|------|------|--------|-------------------|
| | | | OR NO* | |
| n. Getting assistance from drivers | | | | |
| o. Weather | | | | |
| p. Buses not arriving on time | | | | |
| q. Attitude of other passengers | | | | |
| r. Feeling safe while bus is moving | | | | |

25. Now I'd like to ask you how important you feel various changes would be. For each one say whether you feel it would be very important, moderately important, or not important.

| | Very Important | Moderately Important | Not Important |
|---|----------------|----------------------|---------------|
| a. A different lift design | 1 | 2 | 3 |
| (DON'T ASK IF "NOT IMPORTANT") What changes would you like to see made to the lifts? | | | |
| b. More buses on accessible routes should have lifts | 1 | 2 | 3 |
| c. More routes should be accessible | 1 | 2 | 3 |
| d. Drivers should help more | 1 | 2 | 3 |
| g. Changes to the interiors on the lift buses | 1 | 2 | 3 |
| (DON'T ASK IF "NOT IMPORTANT") What changes would you like to see made to the bus interiors? | | | |
| h. There should be more curb cuts | 1 | 2 | 3 |
| i. Changes to the wheelchair positions in the lift buses | 1 | 2 | 3 |
| (DON'T ASK IF "NOT IMPORTANT") What changes would you like to see made to the wheelchair positions? | | | |
| j. Changes to the wheelchair tie-downs. | 1 | 2 | 3 |
| (DON'T ASK IF "NOT IMPORTANT") What changes would you like made to the tie-downs? | | | |
| k. Less crowding on the lift buses during rush hour | 1 | 2 | 3 |

26. How did you first learn about the lift buses?
- | | |
|-----------------------|----------------------|
| 1. Radio | 5. Social agency |
| 2. TV | 6. Word of mouth |
| 3. Newspaper/Magazine | 7. Saw bus on street |
| 4. Bus Demonstration | 8. Other: _____ |
- 27a. Some people have said that there should be special door-to-door transit service for the handicapped. Would you like to see such a service instead of lift-equipped regular buses?
1. Yes 2. No 3. Don't know
- b. Would you like to see door-to-door service in addition to accessible regular buses?
1. Yes 2. No 3. Don't know
28. What do you think could be done to make riding the Metro buses easier, more convenient, or more pleasant?
(HERE COPY DOWN AS PRECISELY AS POSSIBLE THE RESPONDENT'S REPLY.)

29. Do you have any other comments? _____
-
-
-
-

Thank you for taking the time to talk to us. Metro will be using these answers and those of other lift users in future service planning.

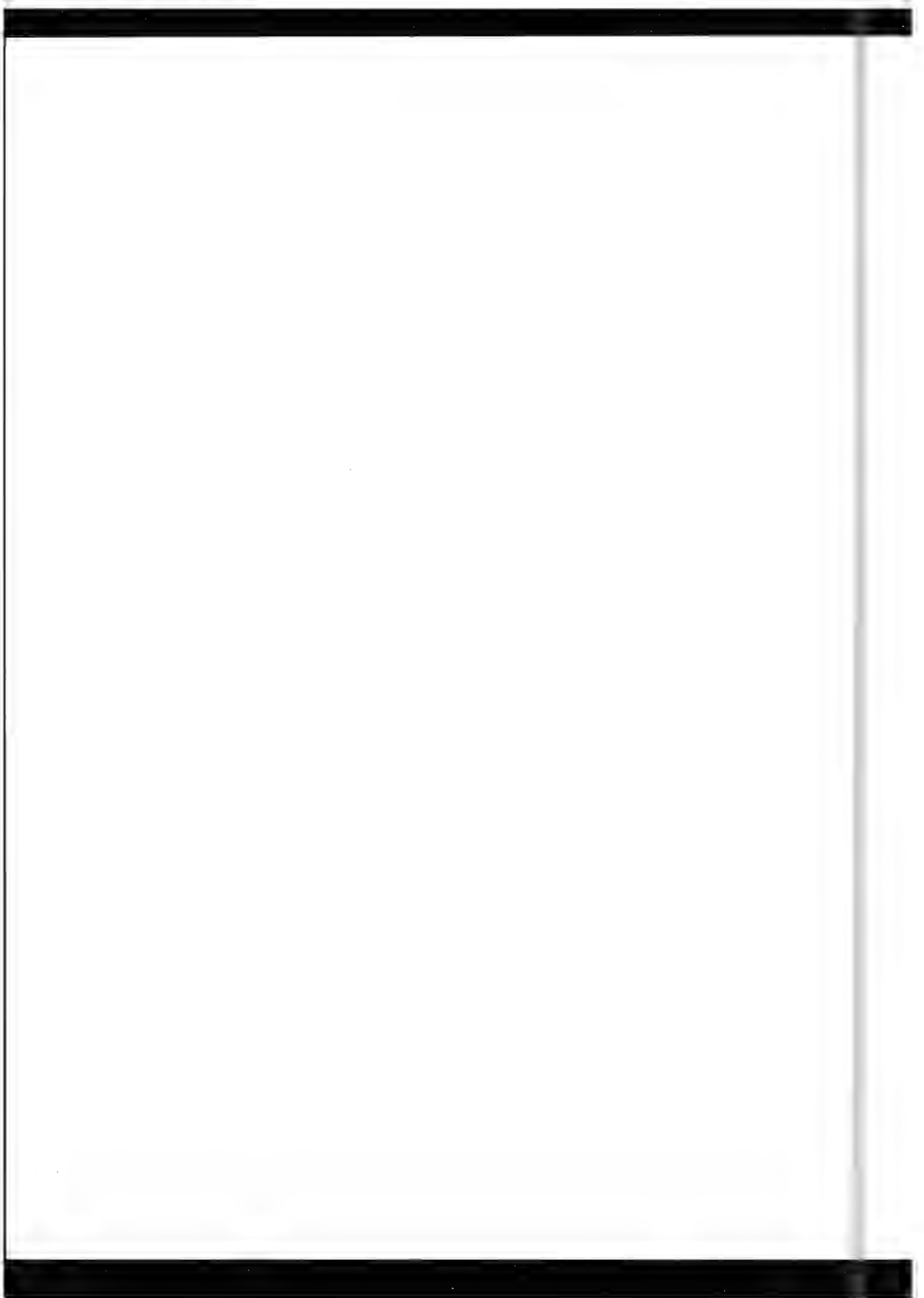

APPENDIX E
POTENTIAL USER SURVEY

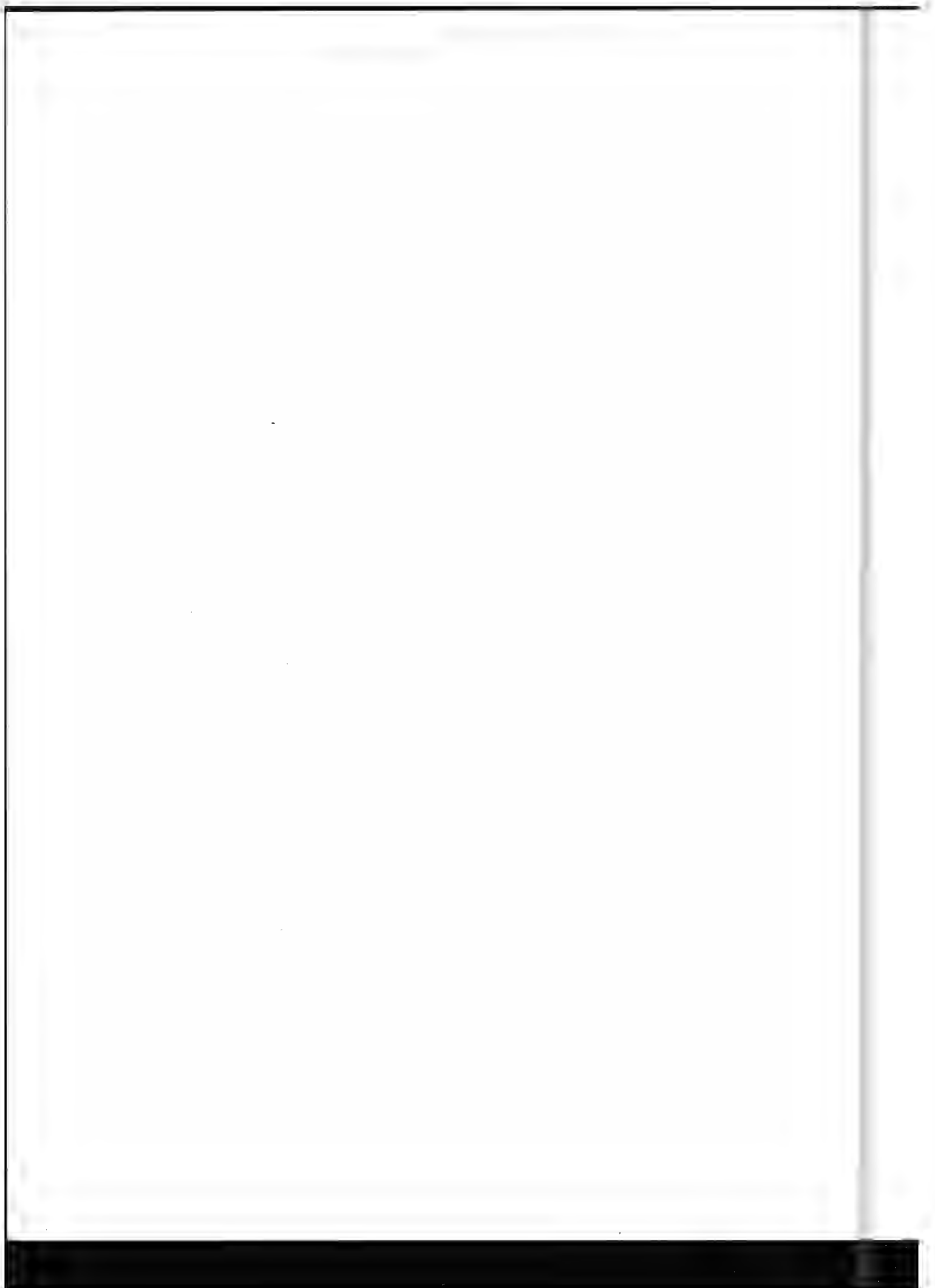

POTENTIAL USER SURVEY MAIL BACK CARD



PLEASE HELP METRO TRANSIT UNDERSTAND YOUR TRANSPORTATION NEEDS BETTER BY COMPLETING THIS CARD. WHEN YOU ARE DONE PLEASE PUT IT IN THE MAIL. NO STAMP IS NECESSARY.

THANK YOU FOR YOUR HELP!

1. DO YOU HAVE DIFFICULTY USING STAIRS?

- NO
 YES, SLIGHT DIFFICULTY YES, EXTREME DIFFICULTY
 YES, MODERATE DIFFICULTY CAN'T USE STAIRS AT ALL

2. DO YOU USE ANY AIDS? (CHECK ALL THAT APPLY)

- MANUAL WHEELCHAIR CRUTCHES
 ELECTRIC WHEELCHAIR BRACES
 WALKER NONE
 CANE OTHER: _____

3. DID YOU KNOW THAT METRO NOW HAS BUSES EQUIPPED WITH LIFTS ON MANY OF ITS ROUTES?

- YES NO

4. HAVE YOU EVER USED ANY OF THESE LIFT EQUIPPED BUSES?

- YES NO

5. WOULD YOU HAVE ANY INTEREST IN USING THE BUS IF YOU WERE ABLE TO GET ON AND OFF EASILY?

- YES NO

WE WOULD LIKE TO FIND OUT MORE ABOUT YOUR TRANSPORTATION NEEDS. IF YOU WOULD BE WILLING TO TALK TO ONE OF OUR METRO SURVEY TEAM, PLEASE FILL IN YOUR PHONE NUMBER:

PHONE NO. _____ WHO SHOULD WE ASK FOR? _____

IF YOU DO NOT HAVE A PHONE OR WOULD PREFER A PERSONAL VISIT, PLEASE FILL IN YOUR HOME ADDRESS. WE WILL CONTACT YOU AND MAKE AN APPOINTMENT TO SEE YOU.

ADDRESS: _____
NO. STREET APT. OR ROOM NO. CITY

BEST TIME FOR US TO CALL OR MAKE AN APPOINTMENT TO VISIT:

- WEEKDAY MORNING
 WEEKEND AFTERNOON EVENING

Thank You. Just Put This Card in the Mail. No Stamp is Needed

NO-CARD VERSION

SURVEY OF POTENTIAL USERS OF SEATTLE METRO LIFT-BUSES

Respondent's Name _____

Respondent's Phone _____

Respondent's Address: _____

CALL RECORD

| Date | Time | Outcome |
|------|------|---------|
| | | |
| | | |
| | | |

(ASK FOR RESPONDENT BY NAME IF AVAILABLE, AND READ INTRODUCTION TO RESPONDENT.
IF NO NAME, USE ALTERNATE VERSION OF INTRODUCTION WITH PERSON ANSWERING.)

INTRODUCTION: Hello, my name is _____, and I'm calling for Metro Transit. You (a member of your household) recently spoke with a member of our survey team about Metro's new lift-equipped buses. You (they) said you (they) would be willing to answer a few more questions if we called (came to visit). Can you talk with me now? (Is that person home?)

(REPEAT INTRO TO RESPONDENT, IF NECESSARY)

1. Do you have difficulty using stairs? (IF YES, ASK FOR DEGREE OF DIFFICULTY USING THE CATEGORIES BELOW)

- 1. No
 - 2. Yes, slight difficulty
 - 3. Yes, moderate difficulty
 - 4. Yes, extreme difficulty
 - 5. Can't use stairs at all
- } (IF "NO" OR "SLIGHT DIFFICULTY," TERMINATE INTERVIEW.)

2. What aids do you use?

- 1. Manual wheelchair
- 2. Electric wheelchair
- 3. Walker
- 4. Cane
- 5. Crutches
- 6. Braces
- 7. None
- 8. Other _____

(THERE IS NO QUESTION 3 ON THIS VERSION.)

CARD VERSION

SURVEY OF POTENTIAL USERS OF SEATTLE METRO LIFT-BUSES

Respondent's Name _____

Respondent's Phone _____

Respondent's Address: _____

CALL RECORD

| Date | Time | Outcome |
|------|------|---------|
| | | |
| | | |
| | | |

*(ASK FOR RESPONDENT BY NAME IF SUPPLIED, AND READ INTRODUCTION TO RESPONDENT.
IF NO NAME, USE ALTERNATE VERSION OF INTRODUCTION WITH PERSON ANSWERING.)*

INTRODUCTION: Hello, my name is _____, and I'm calling for Metro Transit. You (a member of your household) recently sent in a card from a survey of people interested in using Metro's new lift-equipped buses. You (they) said you (they) would be willing to answer a few more questions if we called (came to visit). Can you talk with me now? (Is that person home?)

(REPEAT INTRO TO RESPONDENT, IF NECESSARY)

First, I'd like to check over some of the information I have from the card that you sent in.

1. The first question on the card was about difficulty using stairs. You said that you *(REPEAT ANSWER FROM CARD)*. Do I have that right?
(INDICATE FINAL ANSWER BELOW)

1. No
2. Yes, slight difficulty
3. Yes, moderate difficulty
4. Yes, extreme difficulty
5. Can't use stairs at all

(IF "NO" OR "SLIGHT DIFFICULTY," TERMINATE INTERVIEW.)

2. You said you use a *(READ AIDS FROM CARD)*. Is that right? Do you use any other aids? *(INDICATE FINAL ANSWERS BELOW.)*

- | | |
|------------------------|----------------|
| 1. Manual wheelchair | 5. Crutches |
| 2. Electric wheelchair | 6. Braces |
| 3. Walker | 7. None |
| 4. Cane | 8. Other _____ |

3. *(RECORD ANSWER TO AWARENESS QUESTION FROM CARD.)*

1. Yes
2. No

- 4a. I'd like to clarify at this point that we are talking about the buses on Metro's regularly scheduled routes, which serve non-handicapped as well as handicapped passengers. Some of these buses have been equipped with lifts in the front of the bus, to enable passengers to get on and off without using the stairs. Have you used these lift-equipped buses during the last month?
1. Yes (*SWITCH TO MAILING LIST VERSION OF USER SURVEY: START AT Q.1*)
 2. No

b. Have you ever used the lift buses?

1. Yes
2. No

5. Now I would like to read several reasons why people might not use the lift bus service. For each one, please tell me whether or not it is a reason why you are not currently using the lift buses.

| | <u>Yes</u> | <u>No</u> |
|---|------------|-----------|
| a. You were not aware of the service. | 1 | 2 |
| b. The bus doesn't go where you want to go. | 1 | 2 |
| c. The buses do not run at convenient times. | 1 | 2 |
| d. You can't go out of the house without help. | 1 | 2 |
| e. The bus stop is not convenient to your home. | 1 | 2 |
| f. You are physically unable to get to the bus stop. | 1 | 2 |
| g. Dealing with traffic might be dangerous. | 1 | 2 |
| h. It might be hard to get into or maneuver within the vehicle. | 1 | 2 |
| i. You don't like crowds. | 1 | 2 |
| j. It might be embarrassing to use the bus. | 1 | 2 |
| k. Transferring between buses would take too long. | 1 | 2 |
| l. Transferring between buses would be physically difficult for you. | 1 | 2 |
| m. It is too hard to get directions. | 1 | 2 |
| n. The system is too confusing or complicated to understand. | 1 | 2 |
| o. Waiting outdoors for the bus is too tiring or uncomfortable. | 1 | 2 |
| p. Frequent starts and stops on the bus would be a problem. | 1 | 2 |
| q. You prefer to use other means of transportation. | 1 | 2 |
| r. Is there any other reason why you do not use the lift bus service? | | |

6. Do you have any plans to start using the lift buses in the future?
1. Yes
 2. No
 3. Maybe/Dont' know
7. How far is it from your home to a regular Metro bus stop?
1. Less than one block
 2. About one block
 3. About two blocks
 4. Three or more blocks
 5. Don't know
8. Do you know whether a lift-equipped bus stops there?
1. Yes
 2. No
 3. Don't know
9. Are there any obstacles between your home and the nearest bus stop, which would prevent you from getting there in good weather? For example, are there curbs you can't get over, surfaces that are too rough, or intersections that are too hard to cross?
1. Curbs
 2. Rough surfaces
 3. Intersections
 4. Hills
 5. Other _____ (Specify)
10. If these difficulties were removed, how hard would it be for you to get to the nearest bus stop in good weather? Would it be...
1. Easy?
 2. Slightly difficult?
 3. Fairly difficult?
 4. Very difficult or impossible? Why is that? _____
 5. Don't know.
- 11a. Have you ever seen or taken part in a special demonstration of the lift buses?
1. Yes
 2. No
- b. IF YES, After viewing or taking part in this demonstration, did you feel that you would be able to use the lift when making a trip?
1. Yes
 2. No
 3. Not sure.

12. In this question I will read a list of changes to the lift bus service. For each one tell me, if that change were made, would you be a lot more likely to use the bus, somewhat more likely to use the bus, or would you probably still not use the lift bus.

| | A Lot | Some- what | Probably Not |
|--|-------|---------------|-----------------|
| a. The bus stop was nearer to your home. | 1 | 2 | 3 |
| b. The bus went closer to the places you need to go. | 1 | 2 | 3 |
| c. You didn't have to wait as long for the bus. | 1 | 2 | 3 |
| d. You didn't have to transfer between buses. | 1 | 2 | 3 |
| e. It was made easier to get on and off the lift platform. | 1 | 2 | 3 |
| f. You felt safer riding up and down on the lift. | 1 | 2 | 3 |
| g. It was made easier to pay the bus fare. | 1 | 2 | 3 |
| h. It was made easier to get to a seat or the wheelchair position. | 1 | 2 | 3 |
| i. WHEELCHAIR ONLY. It was made easier to secure your chair in place so it doesn't move around. | 1 | 2 | 3 |
| j. It was made easier to signal when you want to get on and off. | 1 | 2 | 3 |
| k. The buses were less crowded. | 1 | 2 | 3 |
| l. The drivers gave you more assistance. | 1 | 2 | 3 |
| m. (IF "PROBABLY NOT" TO ALL) Is there any combination of several of the changes I have just read that would make it more likely that you would use the bus? | | | |

n. Are there any other changes you can think of that would make it more likely that you would use the lift buses?

13a. Some people have said that there should be special door-to-door transit service for the handicapped. Metro has no plan to begin such a service at this time; however, we would like to know if you would like to see such a service instead of lift-equipped regular buses?

1. Yes 2. No 3. Don't know

13b. Would you like to see door-to-door service in addition to accessible regular buses?

1. Yes 2. No 3. Don't know

14. Now, I'd like to ask you about the trips you presently make around town. Considering all the ways you make trips, such as by driving, getting rides, taking the taxi, using an agency service, and so on, about how often do you go places around town?

1. 4 or more times a week 4. 2 or 3 times a month
 2. 2 or 3 times a week 5. Once a month or less
 3. About once a week 6. Don't travel at all— GO TO 17b.

15. Do you make trips to go to (READ PURPOSE). About how often do you go to (PURPOSE)? What means of transportation do you use for these trips? Do you now make any of these trips using taxis, Grey Top or Far West vans, or social agency transportation services? Would you like to make any of these trips using the lift buses?

| | HOW OFTEN | | | | | MEANS OF TRANSPORTATION | | | | | | | USE LIFT BUS | | |
|--------------------------------------|-----------|------|----|------|----|-------------------------|------|------|-----|--------|-------|-------|--------------|----|------|
| | 4/ | 2-3/ | 1/ | 2-3/ | 1/ | Drive | Ride | Taxi | Van | Agency | Walk/ | | Not | | |
| | wk | wk | wk | mo | mo | | | | | | Wheel | Other | Yes | No | Sure |
| a. Work | 1 | 2 | 3 | 4 | 5 | 1 | 2 | 3 | 4 | 5 | 6 | 7 | 1 | 2 | 3 |
| b. Shop | 1 | 2 | 3 | 4 | 5 | 1 | 2 | 3 | 4 | 5 | 6 | 7 | 1 | 2 | 3 |
| c. School | 1 | 2 | 3 | 4 | 5 | 1 | 2 | 3 | 4 | 5 | 6 | 7 | 1 | 2 | 3 |
| d. Recreation/ Visit people | 1 | 2 | 3 | 4 | 5 | 1 | 2 | 3 | 4 | 5 | 6 | 7 | 1 | 2 | 3 |
| e. Conduct per- sonal business | 1 | 2 | 3 | 4 | 5 | 1 | 2 | 3 | 4 | 5 | 6 | 7 | 1 | 2 | 3 |
| f. Medical or rehab. appointments | 1 | 2 | 3 | 4 | 5 | 1 | 2 | 3 | 4 | 5 | 6 | 7 | 1 | 2 | 3 |
| g. Other _____ (specify) | 1 | 2 | 3 | 4 | 5 | 1 | 2 | 3 | 4 | 5 | 6 | 7 | 1 | 2 | 3 |

16. Are you registered for Metro's discount taxi scrip program?

1. Yes 2. No

17a. Do you usually travel alone or with a friend or assistant.

1. Alone
 2. Attended
 3. Sometimes one, sometimes other.

b. If you were going to use the present lift bus service, do you think you would travel alone, or with a friend or assistant?

1. Alone
 2. Attended
 3. Sometimes one, sometimes other.

18. What type of housing do you live in?
1. Private house or apartment
 2. Special housing for the handicapped
 3. Nursing home or other type of institution
 4. Other _____
19. Finally, a couple of questions for statistical purposes. Are you...
1. Under 20 years old?
 2. 20-34?
 3. 35-54?
 4. 55-64?
 5. 65 or older?
20. Is the combined income of you and any other members of your household, before taxes are taken out...
1. Under \$5,000 a year?
 2. Over \$5,000 but under \$10,000?
 3. Over \$10,000 but under \$20,000?
 4. Over \$20,000 but under \$30,000?
 5. Or over \$30,000?
 6. Don't know/refused.
21. Those are all the questions I have. Is there anything else you'd like to say that I can pass on to Metro?

Thank you for taking the time to talk to us. Metro will be using these answers and those of other respondents in future service planning.

APPENDIX F
CARD USED IN LIFT USE COUNTS

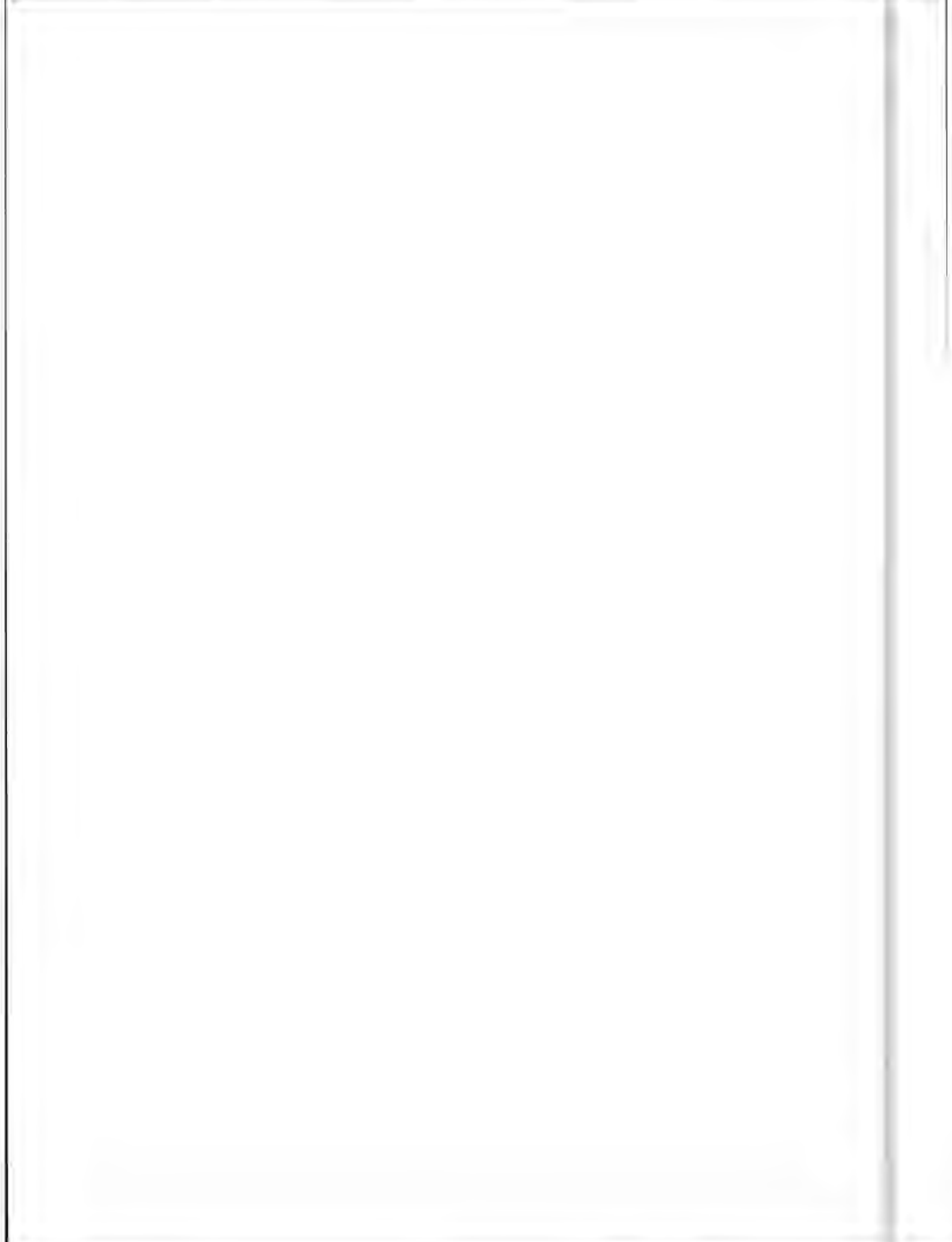

CARD USED IN LIFT USE COUNTS

METRO TRANSIT
TRANSIT DEVELOPMENT DIVISION
MAIL STOP 52

WHEELCHAIR LIFT PASSENGER COUNT

COMBO # _____

TUESDAY JUL 22 1980

ROUTE/
RUN # 317/01

DATE: _____

SIGN-IN
TIME: 542A

COACH # 1723

PLEASE RECORD THE TOTAL NUMBER OF:

(1) wheelchair-bound passengers
you carried on your run: 1

(2) other handicapped passengers
(not wheelchair-bound) who
required the lift: 0

(3) passengers requiring lifts
who were passed up because
of overloads: 0

(4) passengers requiring lifts
who were passed up because
of lift malfunction: 0

PLEASE USE THE BACK OF THIS CARD FOR ANY COMMENTS
YOU MAY HAVE REGARDING ACCESSIBLE SERVICE.

OPERATOR'S ID # 150

PLEASE RETURN CARD TO BASE DISPATCHER. THANK YOU

DISPATCHER: PLEASE RETURN CARD TO TRANSIT DEVEL.
DIVISION (MAIL STOP 52) - WATKINS

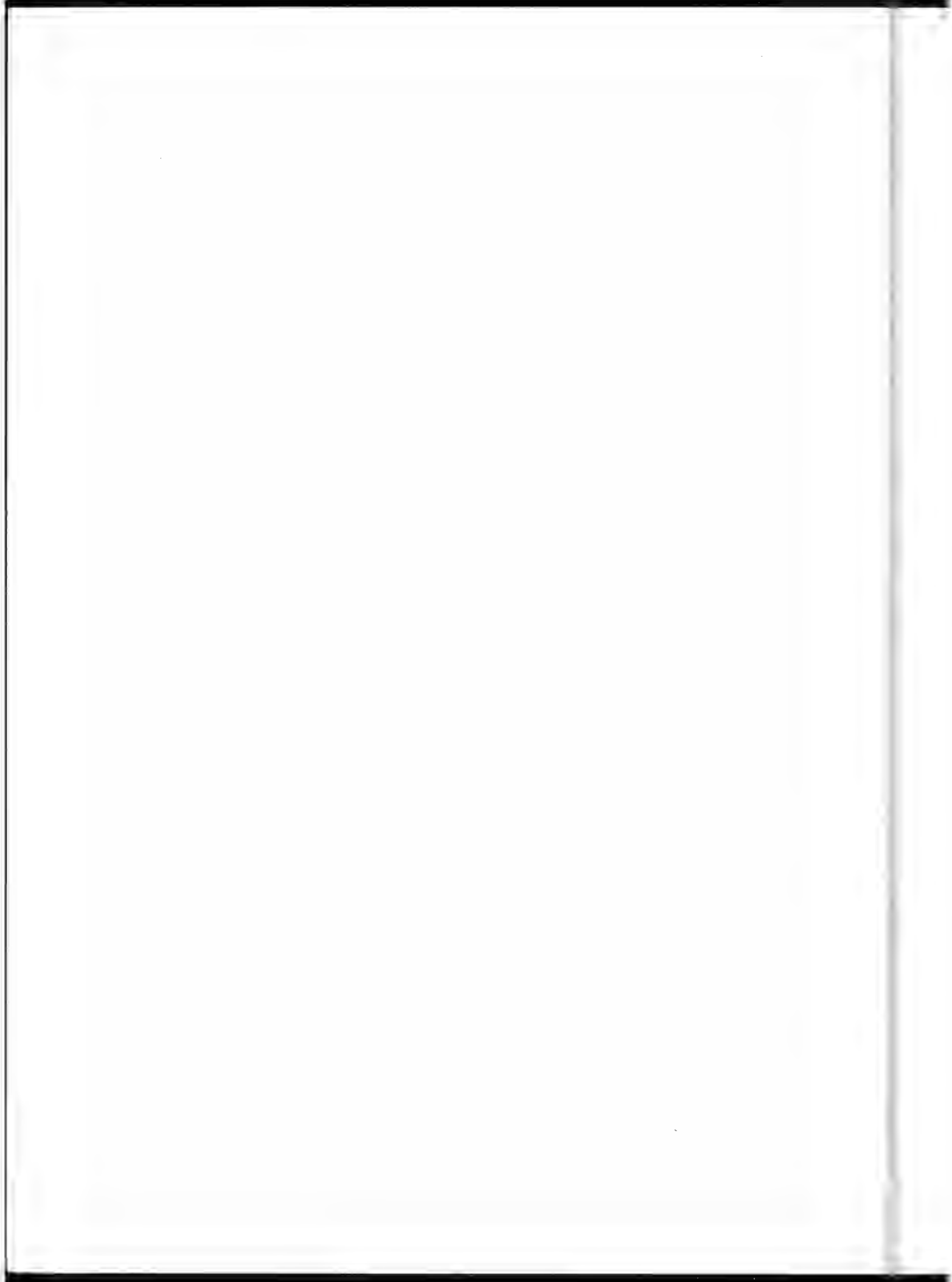

APPENDIX G
REPORT OF NEW TECHNOLOGY

REPORT OF NEW TECHNOLOGY

The report describes recent improvements in the observed reliability of wheelchair lifts for use in public transit buses. However, no new technology is reported.

300 copies

☆U. S. GOVERNMENT PRINTING OFFICE: 1982--500-916--351