



Ohio Department of Transportation

Richard F. Celeste/Governor

Warren J Smith/Director

An Equal Opportunity Employer

VEHICLE CATALOG

**Developed for the Fiscal Year 1983
UMTA Section 16(b)(2) Program**

April 1983

06231

TL
232
.042
1983

VEHICLE CATALOG
Developed for the
F.Y. 1983 UMTA Section 16(b)(2) Program

April, 1983

Donald G. Meacham, P.E. Supervisor
W. David Wood, P.E.
Hart S. James
of
Division of Public Transportation
Ohio Department of Transportation

Preparation of this report has been financed in part through a grant from the Urban Mass Transportation Administration.

1. Report No. DOT-I-83-49		2. Government Accession No.		3. Recipient's Catalog No.	
4. Title and Subtitle FY-1983 VEHICLE CATALOG (Developed for Fiscal Year 1983 UMTA Section 16(b)(2) Program)				5. Report Date April 1983	
				6. Performing Organization Code	
7. Author(s) D.G. Meacham, W.D. Wood, H.S. James				8. Performing Organization Report No. ODOT-BPT-008	
9. Performing Organization Name and Address Ohio Department of Transportation Division of Public Transportation 25 South Front Street Columbus, Ohio 43216-0899				10. Work Unit No. (TRAVIS) N/A	
				11. Contract or Grant No. UMTA-09-8008	
12. Sponsoring Agency Name and Address U.S. Department of Transportation Urban Mass Transportation Administration 400 Seventh Street, S.W. Washington, D. C. 20590				13. Type of Report and Period Covered Annual; Fiscal Year 1983	
				14. Sponsoring Agency Code DOT/UMTA	
15. Supplementary Notes Data collection and report preparation financed in part by UMTA Grant No. OH-09-8008; distributed by DOT's Technology Sharing Program.					
16. Abstract This publication contains information which can be used by operators of small transit systems and social service transportation providers to help in the selection of the vehicle/s and ancillary equipment needed for the agency's transportation program. The catalog includes guidance for the selection of a small transit vehicle; a discussion on preventative maintenance; detailed information, with illustrations and example floor plans, for the types and sizes of vehicles available in the Ohio program; and a listing, with discussions, of all ancillary equipment available to be added to the selected vehicle. The estimated costs of vehicles and equipment included in this catalog are listed in the last section of this publication.					
17. Key Words Transit Vehicles, Vehicle Ancillary Equipment, UMTA Section 16(b)(2), Small Transit Services, Rural Transit Services, Vehicle Layout			18. Distribution Statement Availability is unlimited. Document is being released to the National Technical Information Service, Springfield, Va. 22161 for sale to the U. S. public.		
19. Security Classif. (of this report) Unclassified		20. Security Classif. (of this page) Unclassified		21. No. of Pages 306	22. Price

TABLE OF CONTENTS

	<u>Page</u>
Title Sheet	i
Technical Report Documentation Page	iii
Table of Contents	v
List of Illustrations	vii
List of Exhibits	xvi
Floor Plans	xvi
I. Introduction and Vehicle Selection	1
Table of Contents for Section I	3
II. Maintaining the Vehicle	11
Table of Contents for Section II	13
III. Types of Vehicles Available	23
A. Van Series	25
Table of Contents for Section III-A	27
1. Standard Vans	31
2. Standard Vans With Ramp	41
3. Converted Vans	49
B. Light Transit Vehicle Series	71
Table of Contents for Section III-B	73
C. Bus Series	101
Table of Contents for Section III-C	103
1. Modified School Buses	107
2. Light Buses	127
3. Light Transit Buses	145
IV. Types of Ancillary Equipment Available	157
Table of Contents for Section IV	159
V. Estimated Costs of Vehicles and Equipment*	271
Table of Contents for Section V	273

* Originally published as a separate supplement.

LIST OF ILLUSTRATIONS

Page

VEHICLES

Standard Vans

Illustration 1 -	Standard 11 Passenger Van- Ford Club Wagon	36
	Source: Ford Motor Corporation	
Illustration 2 -	Standard 11 Passenger Van- Chevrolet Beauville Sportsvan	37
	Source: General Motors Corporation	
Illustration 3 -	Standard 14 Passenger Van- Plymouth Voyager	38
	Source: Chrysler Corporation	

Standard Vans with Rear Mounted Ramp

Illustration 4 -	Standard Van with Rear Mounted Ramp of Expanded Metal	46
	Source: Collins Industries, Inc.	
Illustration 5 -	Standard Van Rear Mounted Ramp Operation	47
	Source: Elderly United of Springfield and Clark County	

Converted Vans

Illustration 6 -	Converted Van Without a Lift	55
	Source: Coach and Equipment Sales Corporation (Fortivan)	
Illustration 7 -	Converted Van With Side Mounted Wheelchair Lift	56
	Source: Bud Industries, Inc.	
Illustration 8 -	Converted Van With Side Mounted Wheelchair Lift	57
	Source: National Coach Corp.	
Illustration 9 -	Converted Van Showing Operation of Side Mounted Wheelchair Lift	58
	Source: The Braun Corporation	

LIST OF ILLUSTRATIONS (CONT'D)

	<u>Page</u>
Illustration 10 - Converted Van Showing Operation of Side Mounted Wheelchair Lift	59
Source: Coach and Equipment Sales Corporation (Fortivan)	
Illustration 11 - Converted Van With Rear Mounted Wheelchair Lift	60
Source: Toledo Society for the Handicapped	
Illustration 12 - Converted Van Interior	61
Source: The Braun Corp.	
Illustration 13 - Interior of Converted Van	62
Source: Bud Industries	
Illustration 14 - Interior of Converted Van Showing First Step	63
Source: Collins Industries	
 <u>Light Transit Vehicles</u>	
Illustration 15 - Light Transit Vehicle - (Modified Van) Collins Omni Bus	80
Source: Collins Industries, Inc.	
Illustration 16 - Light Transit Vehicle - (Body on Conventional Chassis) Wayne Transette	81
Source: Wayne Corporation	
Illustration 17 - Light Transit Vehicle - (Body on Conventional Chassis) Wayne Transette with Wheelchair Lift	82
Source: Wayne Corporation	
Illustration 18 - Light Transit Vehicle - (Body on Conventional Chassis) National Escort II	83
Source: National Coach Corp.	
Illustration 19 - Light Transit Vehicle - (Body on Conventional Chassis) National Escort II	84
Source: National Coach Corp.	
Illustration 20 - Light Transit Vehicle - (Body on Conventional Chassis) Premiere Commuter III	85
Source: Premiere Bus Manufacturing Co.	

LIST OF ILLUSTRATIONS (CONT'D)

	<u>Page</u>
Illustration 21 - Light Transit Vehicle - (Body on Conventional Chassis) Fortibus with Wheelchair Lift	86
Source: Coach and Equipment Sales Corp.	
Illustration 22 - Light Transit Vehicle - (Body on Conventional Chassis) Terravan Transit Van	87
Source: Turtle Top, Inc.	
Illustration 23 - Light Transit Vehicle - (Body on Conventional Chassis) H.C.I. Transporter	88
Source: Handicap Conversions, Inc.	
Illustration 24 - Light Transit Vehicle - (Laminated Honeycomb Fiberglass) Falcon People Mover	89
Source: Clermont Authority for Rural Transportation	
Illustration 25 - Light Transit Vehicle - (Laminated Honeycomb Fiberglass) Diamond People Mover	90
Source: Coons Manufacturing Inc.	
Illustration 26 - Light Transit Vehicle - (Laminated Honeycomb Fiberglass) Diamond People Mover with Wheelchair Lift	91
Source: Coons Manufacturing Inc.	
Illustration 27 - Interior Views of Light Transit Vehicles	92
 <u>Modified School Buses</u>	
Illustration 28 - Modified School Bus (Category A Bus) -Carpenter Cadet "CV"	113
Source: Carpenter Body Works, Inc.	
Illustration 29 - Modified School Bus (Category A Bus) -Carpenter Cadet "CV" with Wheelchair Lift	114
Source: Carpenter Body Works, Inc.	
Illustration 30 - Modified School Bus (Category A Bus) -Blue Bird Mini-Bird	115
Source: Blue Bird Coach	

LIST OF ILLUSTRATIONS (CONT'D)

	<u>Page</u>
Illustration 31 - Modified School Bus (Category A Bus) -Blue Bird Mini-Bird with Wheelchair Lift	116
Source: Blue Bird Coach	
Illustration 32 - Modified School Bus (Category A Bus) -Wayne Lifeguard	117
Source: Wayne Corporation	
Illustration 33 - Modified School Bus (Category A Bus) -Wayne Lifeguard with Wheelchair Lift	118
Source: Wayne Corporation	
Illustration 34 - Modified School Bus (Category A Bus) -Thomas Body on GMC Chassis	119
Source: Thomas Built Buses, Inc.	

Light Buses

Illustration 35 - Light Bus (Category B Bus) -Carpenter Cadet with Wheelchair Lift	133
Source: Carpenter Body Works, Inc.	
Illustration 36 - Light Bus (Category B Bus) -Wide Body Carpenter Cadet	134
Source: Carpenter Body Works, Inc.	
Illustration 37 - Light Bus (Category B Bus) -Thomas Mighty Mite F.C. Tour Bus	135
Source: Thomas Built Buses, Inc.	
Illustration 38 - Light Bus (Category B Bus) -Ward Caravans	136
Source: Ward Industries	
Illustration 39 - Light Bus (Category B Bus) -Ward Amtran	137
Source: Ward Industries	

Light Transit Buses

Illustration 40 - Light Transit Bus (Category C Bus) -Blue Bird Microbird	151
Source: Blue Bird Co.	
Illustration 41 - Light Transit Bus (Category C Bus) -Thomas Minotour	152
Source: Thomas Built Buses, Inc.	

LIST OF ILLUSTRATIONS (CONT'D)

	<u>Page</u>
Illustration 42 - Light Transit Bus (Category C Bus) -Thomas Minotour with Wheelchair Lift . . . Source: Thomas Built Buses	153
Illustration 43 - Light Transit Bus (Category C Bus) -Ward Vanguard Source: American Transportation Corp.	154
Illustration 44 - Light Transit Bus (Category C Bus) -Wayne Chaperone Source: Wayne Corporation	155

LIST OF ILLUSTRATIONS (CONT'D)

Page

ANCILLARY EQUIPMENT

Emergency Equipment

Illustration 45 - First Aid Kits 168
Source: Acme Cotton Products Company, Inc.

Passenger Assist Stanchion

Illustration 46 - Typical Passenger Assist Stanchion 173
Source: Elderly United of Springfield
and Clark County

Illustration 47 - Typical Passenger Assist Stanchion
Diagram 174
Source: The Braun Corp.

Rustproofing

Illustration 48 - Ziebart Rust Proofing 179
Source: Ziebart Rust Proofing Co.

Illustration 49 - Quaker State Metal-Gard Rust
Protection 180
Source: Quaker State Motor Oil. Co.

Wheelchair Lifts

Illustration 50 - Bud Lift 185
Source: Bud Industries

Illustration 51 - REB Lift 186
Source: REB Manufacturing, Inc.

Illustration 52 - Braun Lift 187
Source: The Braun Corporation

Illustration 53 - Braun Lift Operation 188
Source: The Braun Corporation

Illustration 54 - Diagram of Braun Lift. 189
Source: The Braun Corporation

Illustration 55 - Collins Lift 190
Source: Collins Industries, Inc.

Illustration 56 - Collins Lift Operation 191
Source: Collins Industries, Inc.

LIST OF ILLUSTRATIONS (CONT'D)

	<u>Page</u>
Illustration 57 - Coach and Equipment Lift	192
Source: Coach and Equipment Sales Corp.	
 <u>Wheelchair Ramps</u>	
Illustration 58 - Collins Econ-O-Ramp Operation.	197
Source: Collins Industries, Inc.	
Illustration 59 - Collins Econ-O-Ramp Diagram.	198
Source: Collins Industries, Inc.	
 <u>Wheelchair Securement Systems</u>	
Illustration 60 - Aeroquip Wheelchair Securement System - Belts	205
Source: Aeroquip Corporation	
Illustration 61 - Collins Wheelchair Securement System - Locks	206
Source: Collins Industries, Inc.	
Illustration 62 - Collins Wheelchair Securement System - Locks	207
Source: Collins Industries Inc.	
Illustration 63 - Bud Industries Wheelchair Securement System - Locks	208
Source: Piqua Taxicab Company	
 <u>Restraining Devices for Wheelchair Occupants</u>	
Illustration 64 - Velcro Safety Belt	213
Source: Everest and Jennings	
Illustration 65 - Auto Type Seat Belt	214
Source: Everest and Jennings	
 <u>Jump Seats</u>	
Illustration 66 - Ferno-Washington Jump Seat	218
Source: Ferno-Washington, Inc.	
Illustration 67 - Ferno-Washington Jump Seat Diagram	219
Source: Ferno-Washington, Inc.	
Illustration 68 - OTACO Jump Seat	220
Source: OTACO, Transportation Seating Division	

LIST OF ILLUSTRATIONS (CONT'D)

	<u>Page</u>
Illustration 69 - Collins Flip Seat	221
Source: Collins Industries, Inc.	
Illustration 70 - Collins Jump Seat, Installed	223
Source: Coach and Equipment Sales Corp.	
<u>Running Boards</u>	
Illustration 71 - E. Z. Sider Running Board	227
Source: Superior/Ideal Inc.	
Illustration 72 - BIMCO Running Board	228
Source: BIMCO, Inc.	
Illustration 73 - Installed Running Board	230
Source: Elderly United of Springfield and Clark County	
<u>Two-Way FM Radios</u>	
Illustration 74 - General Electric Two-Way Radio	235
Source: General Electric Co.	
Illustration 75 - Motorola Two-Way Radio	236
Source: Motorola Corp.	
Illustration 76 - RCA Two-Way Radio	237
Source: RCA Mobile Communications Systems	
Illustration 77 - Regency Two-Way Radio	238
Source: Regency Electronics	
<u>Handicapped Driver Assist Devices</u>	
Illustration 78 - Driving Aids	243
Source: Wells-Engberg Company, Inc.	
Illustration 79 - Slim Line Control	244
Source: Gresham Driving Aids, Inc.	
<u>Air Conditioning</u>	
Illustration 80 - Typical Rear Unit Air Conditioner for Van "C"'s and LTVs	249
Source: ARA Manufacturing Co.	
Illustration 81 - Typical Air Conditioners for LTVs and Buses	250
Source: Trans/Air Manufacturing	

LIST OF ILLUSTRATIONS (CONT'D)

	<u>Page</u>
<u>Wheelchair Accessibility Symbol</u>	
Illustration 82 - Wheelchair Accessibility Symbol	260
<u>Custom Seats</u>	
Illustration 83 - Typical Standard Passenger Seat (Regular Seat)	265
Source: American Seating Co.	
Illustration 84 - Standard Fiberglass Shell Passenger Seat (Regular Seats)	266
Source: OTACO, Transportation Seating Division	
Illustration 85 - Typical Standard Passenger Seats (Regular Seats)	267
Source: Blue Bird Company	
Illustration 86 - Typical Custom Seats	268
Source: American Seating Co.	
Illustration 87 - Typical Custom Seats	269
Source: OTACO Transportation Seating	
Illustration 88 - Typical Custom Seats	270
Source: The C. E. White Co.	

bPT20I

LIST OF EXHIBITS

	<u>Page</u>
Exhibit 1 - Sample Driver's Vehicle Condition Report	19
Exhibit 2 - Sample Mechanic's Report	20
Exhibit 3 - Sample Fuel and Motor Oil, Battery and Tires Record	21
Exhibit 4 - Sample Record of Repairs	22

FLOOR PLANS

Available Floor Plans for Standard Vans	39
Available Floor Plans for Standard Van with Ramp	48
Available Floor Plans for Converted Vans	64
Available Floor Plans for Light Transit Vehicles	93
Available Floor Plans for Modified School Buses	120
Available Floor Plans for Light Buses	138
Available Floor Plans for Light Transit Buses	156

bPT20L

I. INTRODUCTION AND VEHICLE SELECTION

TABLE OF CONTENTS - SECTION I

	<u>Page</u>
I. <u>INTRODUCTION AND VEHICLE SELECTION</u>	
A. Introduction	I-1
B. Selecting a Vehicle	I-2
C. Elements for Planning Service Needs/Table 1	I-4
D. Guidelines for Matching Vehicle Size and Service Type/Table 2	I-5

A. Introduction

Choosing the proper vehicle can sometimes be the determining factor in whether or not that vehicle serves the purpose for which it was intended.

The Urban Mass Transportation Administration (UMTA) through the Michigan Department of Transportation and Michigan State University has developed a study dealing with lightweight bus operations, such as your agency operates, or is proposing to operate. This study covers such areas as choosing the proper vehicle, basic designs of small buses and vans, maintenance, and overall operation of the vehicle. Excerpts from this study have been incorporated into this vehicle catalog to provide you with some insight when selecting your 16(b)(2) vehicle.

The Division of Public Transportation's Engineering Staff has performed considerable research on seating arrangements and placement of wheelchair lifts and ramps in accessible vehicles. The floor plans shown in this booklet are a result of that research and we believe provide the "happy medium" when considering utilization of available space along with comfort and safety of the wheelchair bound as well as ambulatory passengers. Unless specifically requested, wheelchair lifts will be located in the side, and wheelchair ramps will be located in the rear of the vehicle. In making this decision several factors must be considered which are discussed in greater detail in the appropriate sections of this catalog.

If you feel your needs are considerably different than the norm for seating arrangements, so indicate in your application and if your organization receives approval, we will discuss your special needs prior to the purchase of your vehicle.

For further assistance in selecting your 16(b)(2) vehicle, feel free to contact this office or your appropriate MPO, if applicable.

Ohio Department of Transportation
Division of Public Transportation
25 South Front Street, Room 710
Columbus, Ohio 43216-0899
(614) 466-8955

B. Selecting A Vehicle

Matching the proper vehicle with the type of service can strongly improve the efficiency of an operation. However, selecting that vehicle can be a difficult task.

Larger vehicles (buses) may be more effectively utilized for longer trips, while smaller vehicles (vans) seem better suited for dial-a-ride type door-to-door service for short trips. The vans and modified vans may become uncomfortable for passengers over long distances due to the limited interior space, and are usually impractical for passenger loads of more than twelve to fourteen. A twenty-passenger small bus may be difficult to maneuver in city traffic or in narrow city streets and is also inefficient for use with small passenger loads. Using one size of vehicle for all types of service can be a costly mistake. Therefore, it is important to carefully plan service needs prior to the purchase of a vehicle.

The planning of service needs requires, at a minimum, the determination and evaluation of the elements shown in Table 1. Each of these elements may influence the size, type, and number of vehicles required.

The estimated maximum demand, estimated mix of wheelchair and seated passengers, as well as the frequency that wheelchair users may be utilizing your system must be considered when choosing a vehicle.

The characteristics of the service area influence both the size of the vehicle and types of optional equipment. The width of the streets in the service area, and the need to maneuver the vehicle in driveways or cul-de-sacs, may require a vehicle with a short wheelbase and small turning radius. Generally, the shorter the wheelbase, the shorter the overall vehicle length, and the more maneuverability offered. For areas with a hilly terrain it may be required to have a vehicle with a low gear ratio in final drive. However, the need to travel long distances on level ground at high speeds would indicate that a high gear ratio is required.

The availability of service opportunities may also dictate the selection of a particular vehicle since local dealership service, especially for work done under the vehicle warranty, can save a great deal of time when problems occur. Finding local service for certain vehicles may be difficult, especially for vehicle body repairs and wheelchair lift maintenance.

To maximize vehicle utilization, it is usually preferable to select the smallest vehicle (while remembering that some reserve seat capacity is desirable) that can safely and comfortably accommodate the anticipated demand.

Some possible guidelines for matching vehicle size and type of service developed for rural public transportation operators are shown in Table 2. These guidelines may be helpful when determining which type of vehicle to select for your particular agency.

Vehicles and optional equipment available for this year's 16(b)(2) program may be found on the following pages. Please read the descriptions carefully and contact this office or your appropriate MPO, if applicable, with any questions you may have.

Table 1

C. Elements for Planning Service Needs

- | | |
|---|---|
| <p>1. Type of Service</p> <ul style="list-style-type: none">-Demand Responsive-Fixed Route-Special Service | <p>3. Demand Characteristics</p> <ul style="list-style-type: none">-Maximum Number of Passengers to be Carried at One Time-Mix of Wheelchair and Seated Passengers to be Carried |
| <p>2. Service Characteristics</p> <ul style="list-style-type: none">-Number of Trips per Day-Length of Round Trip-Time of Day | <p>4. Service Area Characteristics</p> <ul style="list-style-type: none">-Terrain and Condition of Roads-Size of Service Area-Type of Street System-Climate |

Table 2

D. Guidelines for Matching Vehicle Size and Service Type

<u>Service Type</u>	<u>Variation of Service Type</u>	<u>Vehicle Size</u>
I. Demand Response Operating Patterns	A. "Pure Demand" - Same day door-to-door service within a small area.	8-12 passenger
	B. "Advance Reservation" - planned trip service. Usually scheduled 24-hours in advance of trip	8-12 passenger or larger depending on trip length, demand and terrain
II. Fixed Route Service Patterns	A. "Fixed Schedule" - vehicle follows a prescribed path with defined pickup points	16-19 passenger or larger depending on trip length
	B. "Route Deviation" - vehicle leaves fixed route to pick up or drop off passengers	12-16 passenger, 16-19 passenger depending on terrain
III. Special Service Transportation	A. "Group Service" - single point to point service	Size determined by number of passengers
	B. "Agency Client" - frequent human service trips to and from agency locations	12-16 passenger, 16-19 passenger depending on terrain
	C. "Subscription Service" - normally work trip service. Also includes standing orders	8-12 passenger, 12-16 passenger depending on trip length

sPT20C

II. MAINTAINING THE VEHICLE

TABLE OF CONTENTS - SECTION II

	<u>Page</u>
II. <u>MAINTAINING THE VEHICLE</u>	
A. Preventive Maintenance	II-1
B. Elements of the Pre-Trip Daily Vehicle Inspection/Table 3	II-4
C. Exhibit 1 - Sample Drivers Vehicle Condition Report	II-5
Exhibit 2 - Sample Mechanic's Report	II-6
Exhibit 3 - Sample Fuel and Motor Oil, Battery, and Tires Record	II-7
Exhibit 4 - Sample Record of Repairs	II-8

A. Preventive Maintenance

Preventive maintenance means performing certain regular maintenance procedures on a vehicle to prevent malfunctions, rather than waiting until something goes wrong and then fixing it. It also means performing necessary repairs promptly, so as to keep damage minimal. Before you take delivery on your first vehicle, you should have firm arrangements for maintaining it. A good preventive maintenance program is as important to a successful transportation system as the purchase of the vehicles themselves.

It may be advantageous to handle maintenance in one of several ways:

- 1) Contract maintenance out to commercial mechanics.
- 2) Arrange with other agencies, such as city or county garages, or school bus operators, to maintain vehicles.
- 3) Set up an "in-house" maintenance facility.
- 4) Keep some maintenance work "in-house" and contract out other work, depending on the job.

Once you have arranged for your maintenance facilities and personnel, work with your drivers and mechanics to develop a basic maintenance schedule. The drivers, or other attendants, can perform an important function in vehicle maintenance through a systematic daily inspection of each vehicle. The daily inspection should be made prior to each day's use of the vehicle and should include a thorough examination of the vehicle exterior, interior, and engine compartment. The items in Table 3 represent the most important elements of the daily check. Daily records should be kept for each vehicle indicating any damage sustained, repairs or adjustments necessary, and the amount of any fluid added to the vehicle. Problems should be reported immediately.

Mechanics should be made aware of the minimum maintenance requirements for each vehicle. Manufacturers' recommendations vary for each type of vehicle, but with every vehicle, certain maintenance must be performed either at a specific mileage or within a specific period of time, or the vehicle's reliability will suffer, its worklife may be shortened, and the warranty provisions may be violated.

The following is a suggested maintenance schedule for vans and small buses in passenger service:

Every month:

- 1) Change motor oil.
- 2) Replace oil, air, and fuel filters.
- 3) Lubricate chassis.

Every 8,000 miles:

1. Check brakes, replace parts if necessary.
2. Check wheel bearings, repack or replace if necessary.

Every 10,000 miles:

- 1) Rotate tires, replace if necessary.

Every 12,000 miles:

- 1) Tune engine.
- 2) Replace spark plugs.

Every 15,000 miles:

- 1) Service transmission.
- 2) Change oil in rear axle differential.

As needed:

- 1) Spark plug and coil wires.
- 2) Belts and hoses.

In addition, other items of maintenance are bound to arise:

- 1) Rustproofing, if not included in purchase specifications.
- 2) Alternator replacement.
- 3) Starter motor replacement.
- 4) Windshield wiper motor replacement.
- 5) Exhaust components, including mufflers, manifolds, pipes, hangers and clamps.
- 6) Headlamps, and bulbs for turn signals, brake lights and marker lights.
- 7) Vehicle interior fittings and seat materials.
- 8) Windshield wiper blades.
- 9) Wheelchair lift components.
- 10) Wheelchair restraint components.

Replacement frequency for these unscheduled items varies widely with operating conditions. Unscheduled repairs will occur in any transportation system, and preparations should be made to take care of them quickly.

It should be remembered that a manufacturer may recommend a more frequent schedule for specific maintenance items, in which case the manufacturer's recommended maintenance schedule must be followed.

Remember also that regular washing and cleaning are important to good maintenance, especially where salt is used for clearance of roads and sidewalks. Accumulated salt will greatly accelerate rusting. Where chloride compounds are used to control dust on unpaved roads, they may even cause a corrosion problem in summer. It is thus important to plan for regular and frequent washing as part of basic maintenance.

Whatever arrangement you make for maintenance, the important thing is that someone must take the responsibility for seeing to it that the maintenance actually gets done. Transportation staff should understand that they are individually and jointly responsible for the condition of the vehicles. Drivers should be encouraged to report any malfunctions, and the transportation manager should see to it that repairs are performed promptly. In general, the faster repairs are made, the less they cost, and the better the preventive maintenance, the fewer repairs are necessary.

Table 3 shows some suggestions for the daily inspection of vehicles. Exhibits 1 thru 4, shown in Section C, are examples of how maintenance records can be maintained. Utilizing some type of maintenance records is strongly recommended.

B. Table 3 - Elements of the Pre-Trip Daily Vehicle Inspection

<u>Exterior Inspection</u>	<u>Interior Inspection</u>	<u>Engine Compartment</u>
-Headlights	-Wheelchair Lift	-Fluid Levels
-Turnsignals	-Wheelchair Restraints	Motor Oil
-Back-up Lights	-Passenger Restraints	Transmission
-Tires, for inflation and tread wear	-Brakes	Brake
-Windshield Wipers	-Steering	Steering
-Windows	-Transmission Selector	Radiator
-Mirrors	-Gauges and Indicators	Battery
-Cleanliness	-Cleanliness	Windshield Washer
-Body Damage		-Belts and Hoses

sPT20D

C.Exhibit 1 - Sample Driver's Vehicle Condition Report

DRIVER'S VEHICLE CONDITION REPORT

Date	Mileage In	Mileage Out		
Truck, Tractor or Bus No.		Trailer No.		
Items checked below require attention.				
<table style="width:100%; border:none;"> <tr> <td style="width:50%; vertical-align:top;"> <input type="checkbox"/> Ammeter <input type="checkbox"/> Oil Pressure <input type="checkbox"/> Air or Vacuum Pressure <input type="checkbox"/> Fuel Gauge <input type="checkbox"/> Water Temperature Gauge <input type="checkbox"/> Speedometer <input type="checkbox"/> Tachometer <input type="checkbox"/> Horn <input type="checkbox"/> Windshield Wiper <input type="checkbox"/> Heater and Defroster <input type="checkbox"/> Mirrors <input type="checkbox"/> Brakes (Foot) <input type="checkbox"/> Brakes (Parking) <input type="checkbox"/> Low Air Pressure or Vacuum Warning Signals <input type="checkbox"/> Clutch <input type="checkbox"/> Gearshift <input type="checkbox"/> Steering <input type="checkbox"/> Door Latches or Locks <input type="checkbox"/> Emergency Equipment * <input type="checkbox"/> Fire Extinguisher <input type="checkbox"/> Battery <input type="checkbox"/> Leaks (Water, Fuel, Oil, Grease) <input type="checkbox"/> Belts (Fan, Generator, Air Compressor, etc.) <input type="checkbox"/> Wheel Chocks <input type="checkbox"/> Tanker Equipment </td> <td style="width:50%; vertical-align:top;"> <input type="checkbox"/> Engine <input type="checkbox"/> Transmission <input type="checkbox"/> Generator <input type="checkbox"/> Starter <input type="checkbox"/> Exhaust System <input type="checkbox"/> Cab Body <input type="checkbox"/> Windshield and Windows <input type="checkbox"/> Wheels, Tires, Lugs or Studs <input type="checkbox"/> Brake Hoses <input type="checkbox"/> Electric Lines <input type="checkbox"/> Hook-up and Fifth Wheel <input type="checkbox"/> Trailer Body <input type="checkbox"/> Load and Fastening Devices <input type="checkbox"/> Springs, U-bolts, Shackles <input type="checkbox"/> Trailer Supports (Dollies) <input type="checkbox"/> Mud Flaps <input type="checkbox"/> Lights (Head) <input type="checkbox"/> Lights (Clearance and Side-Marker) <input type="checkbox"/> Lights (Tail) <input type="checkbox"/> Lights (Stop) <input type="checkbox"/> Lights (Turn Signals) <input type="checkbox"/> Reflectors <input type="checkbox"/> Placards <input type="checkbox"/> Other </td> </tr> </table>			<input type="checkbox"/> Ammeter <input type="checkbox"/> Oil Pressure <input type="checkbox"/> Air or Vacuum Pressure <input type="checkbox"/> Fuel Gauge <input type="checkbox"/> Water Temperature Gauge <input type="checkbox"/> Speedometer <input type="checkbox"/> Tachometer <input type="checkbox"/> Horn <input type="checkbox"/> Windshield Wiper <input type="checkbox"/> Heater and Defroster <input type="checkbox"/> Mirrors <input type="checkbox"/> Brakes (Foot) <input type="checkbox"/> Brakes (Parking) <input type="checkbox"/> Low Air Pressure or Vacuum Warning Signals <input type="checkbox"/> Clutch <input type="checkbox"/> Gearshift <input type="checkbox"/> Steering <input type="checkbox"/> Door Latches or Locks <input type="checkbox"/> Emergency Equipment * <input type="checkbox"/> Fire Extinguisher <input type="checkbox"/> Battery <input type="checkbox"/> Leaks (Water, Fuel, Oil, Grease) <input type="checkbox"/> Belts (Fan, Generator, Air Compressor, etc.) <input type="checkbox"/> Wheel Chocks <input type="checkbox"/> Tanker Equipment	<input type="checkbox"/> Engine <input type="checkbox"/> Transmission <input type="checkbox"/> Generator <input type="checkbox"/> Starter <input type="checkbox"/> Exhaust System <input type="checkbox"/> Cab Body <input type="checkbox"/> Windshield and Windows <input type="checkbox"/> Wheels, Tires, Lugs or Studs <input type="checkbox"/> Brake Hoses <input type="checkbox"/> Electric Lines <input type="checkbox"/> Hook-up and Fifth Wheel <input type="checkbox"/> Trailer Body <input type="checkbox"/> Load and Fastening Devices <input type="checkbox"/> Springs, U-bolts, Shackles <input type="checkbox"/> Trailer Supports (Dollies) <input type="checkbox"/> Mud Flaps <input type="checkbox"/> Lights (Head) <input type="checkbox"/> Lights (Clearance and Side-Marker) <input type="checkbox"/> Lights (Tail) <input type="checkbox"/> Lights (Stop) <input type="checkbox"/> Lights (Turn Signals) <input type="checkbox"/> Reflectors <input type="checkbox"/> Placards <input type="checkbox"/> Other
<input type="checkbox"/> Ammeter <input type="checkbox"/> Oil Pressure <input type="checkbox"/> Air or Vacuum Pressure <input type="checkbox"/> Fuel Gauge <input type="checkbox"/> Water Temperature Gauge <input type="checkbox"/> Speedometer <input type="checkbox"/> Tachometer <input type="checkbox"/> Horn <input type="checkbox"/> Windshield Wiper <input type="checkbox"/> Heater and Defroster <input type="checkbox"/> Mirrors <input type="checkbox"/> Brakes (Foot) <input type="checkbox"/> Brakes (Parking) <input type="checkbox"/> Low Air Pressure or Vacuum Warning Signals <input type="checkbox"/> Clutch <input type="checkbox"/> Gearshift <input type="checkbox"/> Steering <input type="checkbox"/> Door Latches or Locks <input type="checkbox"/> Emergency Equipment * <input type="checkbox"/> Fire Extinguisher <input type="checkbox"/> Battery <input type="checkbox"/> Leaks (Water, Fuel, Oil, Grease) <input type="checkbox"/> Belts (Fan, Generator, Air Compressor, etc.) <input type="checkbox"/> Wheel Chocks <input type="checkbox"/> Tanker Equipment	<input type="checkbox"/> Engine <input type="checkbox"/> Transmission <input type="checkbox"/> Generator <input type="checkbox"/> Starter <input type="checkbox"/> Exhaust System <input type="checkbox"/> Cab Body <input type="checkbox"/> Windshield and Windows <input type="checkbox"/> Wheels, Tires, Lugs or Studs <input type="checkbox"/> Brake Hoses <input type="checkbox"/> Electric Lines <input type="checkbox"/> Hook-up and Fifth Wheel <input type="checkbox"/> Trailer Body <input type="checkbox"/> Load and Fastening Devices <input type="checkbox"/> Springs, U-bolts, Shackles <input type="checkbox"/> Trailer Supports (Dollies) <input type="checkbox"/> Mud Flaps <input type="checkbox"/> Lights (Head) <input type="checkbox"/> Lights (Clearance and Side-Marker) <input type="checkbox"/> Lights (Tail) <input type="checkbox"/> Lights (Stop) <input type="checkbox"/> Lights (Turn Signals) <input type="checkbox"/> Reflectors <input type="checkbox"/> Placards <input type="checkbox"/> Other			
REMARKS (explain unsatisfactory items checked)				
Signature of Driver				
Garage Report				
Date	Signature of Garage Foreman or Mechanic			

III. TYPES OF VEHICLES AVAILABLE

III-A. VAN SERIES

TABLE OF CONTENTS - SECTION III-A

	<u>Page</u>
III. <u>TYPES OF VEHICLES AVAILABLE - A. <u>Van Series</u></u>	III-A-ii
1. <u>Standard Vans</u>	III-A-1
a. Illustration 1 - Standard 11 Passenger Van - Ford Club Wagon	III-A-4
b. Illustration 2 - Standard 11 Passenger Van - Chevrolet Beauville Sportsvan	III-A-5
c. Illustration 3 - Standard 14 Passenger Van - Plymouth Voyager	III-A-6
d. Available Floor Plans for Standard Vans	III-A-7
2. <u>Standard Vans with Ramp</u>	III-A-8
a. Illustration 4 - Standard Van with Rear Mounted Ramp of Expanded Metal	III-A-11
b. Illustration 5 - Standard Van with Rear Mounted Ramp Operation	III-A-12
c. Available Floor Plans for Standard Van with Ramp	III-A-13
3. <u>Converted Vans</u>	III-A-14
a. Illustration 6 - Converted Van Without a Lift	III-A-18
b. Illustration 7 - Converted Van with Side Mounted Wheelchair Lift	III-A-19
c. Illustration 8 - Converted Van with Side Mounted Wheelchair Lift	III-A-20
d. Illustration 9 - Converted Van Showing Operation of Side Mounted Wheelchair Lift	III-A-21
e. Illustration 10 - Converted Van Showing Operation of Side Mounted Wheelchair Lift	III-A-22
f. Illustration 11 - Converted Van with Rear Mounted Wheelchair Lift	III-A-23
g. Illustration 12 - Converted Van Interior	III-A-24
h. Illustration 13 - Interior of Converted Van	III-A-25
i. Illustration 14 - Interior on Converted Van Showing First Step	III-A-26
j. Available Floor Plans for Converted Vans	III-A-27

VAN SERIES

This is a series of vehicles using a standard "Detroit" passenger van as the basic vehicle. The van series offers vehicles with no modifications to the van's exterior (except the addition of a passenger assist stanchion at the side door and the possible addition of running boards); vehicles on which a wheelchair ramp is installed in the rear of the van with no exterior modifications, other than those previously described; and vehicles with extensive modifications such as a raised roof, improved passenger entranceway, more accessible interior seating and a wheelchair lift.

The van series offers the most seats per dollar of investment. Also, vans are the most economical to operate (of the vehicles offered in this catalog) and easiest to maneuver. However, on the un-modified vans the seating is cramped and, especially for the rear-most seats, the accessibility of the seats is very difficult; also, the interior headroom is very low.

Three categories of vehicles are offered in the van series, as follows:

1. Standard Van (Van "A")
2. Standard Van with Ramp (Van "B")
3. Converted Van (Van "C")

The above categories of vans are discussed on the following pages.

III-A. VAN SERIES

1. STANDARD VANS

Standard Vans, VA-11-0 and VA-14-0

The standard American van is offered by a variety of manufacturers. Some features you may expect to find on this type of vehicle include:

- Manufacturer's standard equipment
- Manufacturer's standard transmission (i.e. may be manual type)
- Minimum 300 cubic inch (4.92 liter) engine displacement
- Windows all around
- Spare tire, jack and lug wrench
- Seat belts
- Large outside mirrors
- Choice of manufacturer's standard colors

Vans are offered in either a 11-passenger or a 14-passenger (excluding driver) size.

Several considerations should be taken into account before selecting a standard van as a transportation vehicle. One particular problem with the standard production van is that the interior headroom (about 53 inches from floor to roof; 48 inches at the rear and side entrances) does not allow passengers to stand erect while boarding or leaving the vehicle. This can be especially troublesome for elderly passengers with limited mobility.

Other considerations relating to standard vans include the 20-inch step height from the ground at the side entrance. This height can be extremely difficult for the elderly or for passengers using crutches or walkers to negotiate. This problem has been partially alleviated by the addition of Passenger Assist Stanchions which are installed inside the van adjacent to the front edge of the side (passengers') door entrance way. Further reduction of access problems can be accomplished with the addition of running boards on the sides of the van. The stanchions will be specified for each van as standard equipment. The running boards are optional equipment that must be requested by the agency (See Section IV), however, it is strongly recommended that this option be chosen.

Narrow aisleways make accessibility to seats, especially rearmost seats, in standard vans extremely difficult for passengers with mobility impairments.

Standard production vans have been used successfully to provide transportation for various agencies. In instances where the considerations of limited interior space do not pose a problem, the standard van can be a useful alternative as a transit vehicle.

The sizes of vans offered and ancillary equipment available for this category of vehicles are listed below. Illustrations picturing the vans and available floor plans are shown on the following pages. Descriptive material for ancillary equipment is shown in Section IV. Cost Estimates are given in Section V, a separately published supplement.

Vehicle Category: Van, Type A

Vehicles Available:

<u>Vehicle Designation</u>	<u>Regular Adult Passenger Seating (Excluding Driver)</u>	<u>Special Provisions For Wheelchairs</u>
VA-11-0	11	None
VA-14-0	14	None

Colors Available:

The colors listed below are generic colors available in the van series. Please indicate on the application the color desired for your van. The purchase order, written after the make of vehicle is determined via the bidding process, will specify the brand-name color most closely matching the generic color you choose.

- | | |
|----------------------|---------------|
| 1. White | 6. Dark Brown |
| 2. Black | 7. Light Blue |
| 3. Red | 8. Dark Blue |
| 4. Beige (Off-White) | 9. Grey |
| 5. Tan (Light Brown) | 10. Silver |

Ancillary Equipment (Provided):

The following equipment will be specified for each vehicle and no additional action is required by the agency.

1. Automatic Transmission
2. Power Steering and Power Brakes
3. Heavy-duty Equipment (battery, alternator, cooling system, springs and shock absorbers)
4. Large Fuel Tank (total capacity of at least 33 U.S. gallons)
5. Rear Auxiliary Heater
6. Tinted Glass in windshield and all windows
7. Passenger Assist Stanchion
8. Emergency Equipment
9. Undercoating
10. Rustproofing

Ancillary Equipment (Optional):

The following equipment is available for each vehicle as an option. The agency must specify in its application what options are desired. These options will cost extra; and estimated prices are given in Section V, a separately published supplement.

1. Air Conditioning (front and rear)
2. Larger Engine Size - Minimum 350 cubic inch (5.74 liter) engine displacement
3. Radial Tires
4. Running Boards
5. Two-way FM Radio (VHF-low, VHF-high or UHF band) Mobile Units
6. Driver Hand Controls (for operation of the vehicle)

Unavailable Ancillary Equipment:

The following equipment is not available through this program and should not be requested.

1. Wheelchair lift or ramp
2. Overhead flashing lights
3. Luggage rack
4. Logos painted on the side of the vehicle
5. CB radio, commercial band radio, or tape player
6. Special or fancy wheelcovers
7. Special paint jobs



ILLUSTRATION 1 - STANDARD 11 PASSENGER VAN

FORD CLUB WAGON

Source: Ford Motor Corp.



ILLUSTRATION 2 - STANDARD 11 PASSENGER VAN
CHEVROLET BEAUVILLE SPORTSVAN

Source: General Motors Corp.

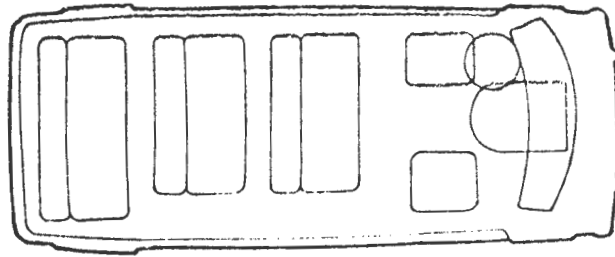

ILLUSTRATION 3 - STANDARD 14 PASSENGER VAN

PLYMOUTH VOYAGER

Source: Chrysler Corporation

AVAILABLE FLOOR PLANS FOR
STANDARD VANS



ELEVEN PASSENGERS PLUS A DRIVER
(127.6" WHEELBASE)

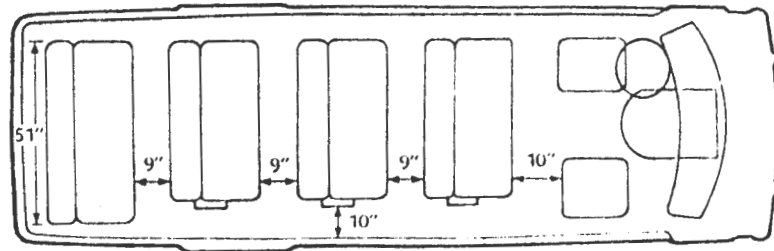

FOURTEEN PASSENGERS PLUS A DRIVER
(127.6" or 138" WHEELBASE)

III-A. VAN SERIES

2. STANDARD VANS WITH RAMP

Standard Vans with Ramps, VB-10-1

Standard vans, as a general rule, are not meant for constant use by wheelchair-bound individuals. A standard van equipped with a wheelchair ramp is just that--no alterations are made to the design of the basic van to allow for maneuvering of a wheelchair inside the vehicle. Wheelchairs are also severely limited as to their positions inside the vehicle, and cannot face one another from opposite sides. Neither can two wheelchairs be accommodated between the vehicle wheelhousings.

As previously mentioned, headroom at the side and rear entrances of a standard van is 48 inches. The minimum clearance (height of lift opening) for a converted van which is specifically designed to carry wheelchairs is 57.5 inches.

The same mobility limitations pointed out for the VA-11-0 and VA-14-0 standard vans are true for the VB-10-1. The dimensions of the seats and aiseways are the same.

Except for the modifications necessary to add the wheelchair ramp and wheelchair position, the VB-10-1 has essentially the same standard features as the VA-11-0 and VA-14-0.

As described for the Van "A" Series, a Passenger Assist Stanchion will be provided for each van, and running boards are available as an additional cost option.

The wheelchair ramp will be constructed of expanded metal and will have no center steps or toe-cleats. Wheelchair ramps have several inherent disadvantages, such as:

1. The incline is too steep for the wheelchair bound person to negotiate unassisted.
2. Heavy passengers require rather strong individuals to assist them in entering and exiting the vehicle. Usually, two persons are needed to load an occupied wheelchair.
3. Power assist is not available and the ramp must be "man-handled" in and out of the vehicle. Sometimes, the ramp is difficult for women drivers to fold and unfold.
4. Adverse weather conditions can render shoe soles and ramp surfaces very slippery creating extremely dangerous conditions.
5. Driver's view through the interior rear-view mirror is obstructed by the stowed ramp.

For these and other reasons we recommend the wheelchair ramp only for the agency with very infrequent usage projected. Additionally, the ramp will be placed in the rear door(s) allowing it and the wheelchair position to remain out of the way of the ambulatory passengers. Wheelchair ramps can be placed in the side door(s), if desired, however, consideration must be given to the inconvenience caused by partial blocking of the side door.

The same factors of selecting the position of a wheelchair lift must also be considered.

Ancillary equipment for this category of vehicles is listed below. An illustration showing a van with a rear mounted ramp and the floor plan available are shown on the following pages. Descriptive material for ancillary equipment is shown in Section IV. Cost Estimates are given in Section V, a separately published supplement.

Vehicle Category: Van, Type B

Vehicle Available:

<u>Vehicle Designation</u>	<u>Regular Adult Passenger Seating (Excluding Driver)</u>	<u>Special Provisions For Wheelchairs</u>
VB-10-1	10 with WCP Unoccupied 7 with WCP Occupied*	Wheelchair Ramp and 1 Wheelchair Postion (WCP)

*Rearmost 3-passenger seat may be easily removed to accommodate a wheelchair secured in the wheelchair position.

Colors Available:

The colors listed below are generic colors available in the van series. Please indicate on the application the color desired for your van. The purchase order, written after the make of vehicle is determined via the bidding process, will specify the brand-name color most closely matching the generic color you choose.

- | | |
|----------------------|---------------|
| 1. White | 6. Dark Brown |
| 2. Black | 7. Light Blue |
| 3. Red | 8. Dark Blue |
| 4. Beige (Off-White) | 9. Grey |
| 5. Tan (Light Brown) | 10. Silver |

Ancillary Equipment (Provided):

The following equipment will be specified for each vehicle and no additional action is required by the agency.

1. Automatic Transmission
2. Power Steering and Power Brakes
3. Heavy-duty Equipment (battery, alternator, cooling system, springs and shock absorbers).
4. Large Fuel Tank (total capacity of at least 33 U.S. gallons)
5. Rear Auxiliary Heater
6. Tinted Glass in windshield and all windows
7. Passenger Assist Stanchion
8. Emergency Equipment
9. Undercoating
10. Rustproofing

Ancillary Equipment (Optional):

The following equipment is available for each vehicle as an option. The agency must specify in its application what options are desired. These options will cost extra; and estimated prices are given in Section V, a separately published supplement.

1. Air Conditioning (front and rear)
2. Larger Engine Size - Minimum 350 cubic inch (5.74 liter) engine displacement
3. Radial Tires
4. Running Boards
5. Two-way FM Radio (VHF-low, VHF-high or UHF band) Mobile Units
6. Driver Hand Controls (for operation of the vehicle)
7. Wheelchair Accessibility Symbol (on outside of vehicle)

Unavailable Ancillary Equipment:

The following equipment is not available through this program and should not be requested.

1. Wheelchair lift (instead of a wheelchair ramp)
2. Overhead flashing lights
3. Luggage rack
4. Logos painted on the side of the vehicle
5. CB radio, commercial band radio, or tape player
6. Special or fancy wheelcovers
7. Special paint jobs

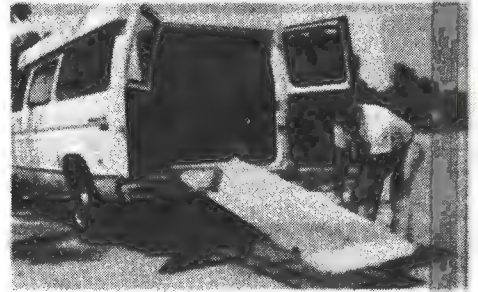

ILLUSTRATION 4 - STANDARD VAN WITH REAR
MOUNTED RAMP OF EXPANDED METAL
Source: Collins Industries, Inc.

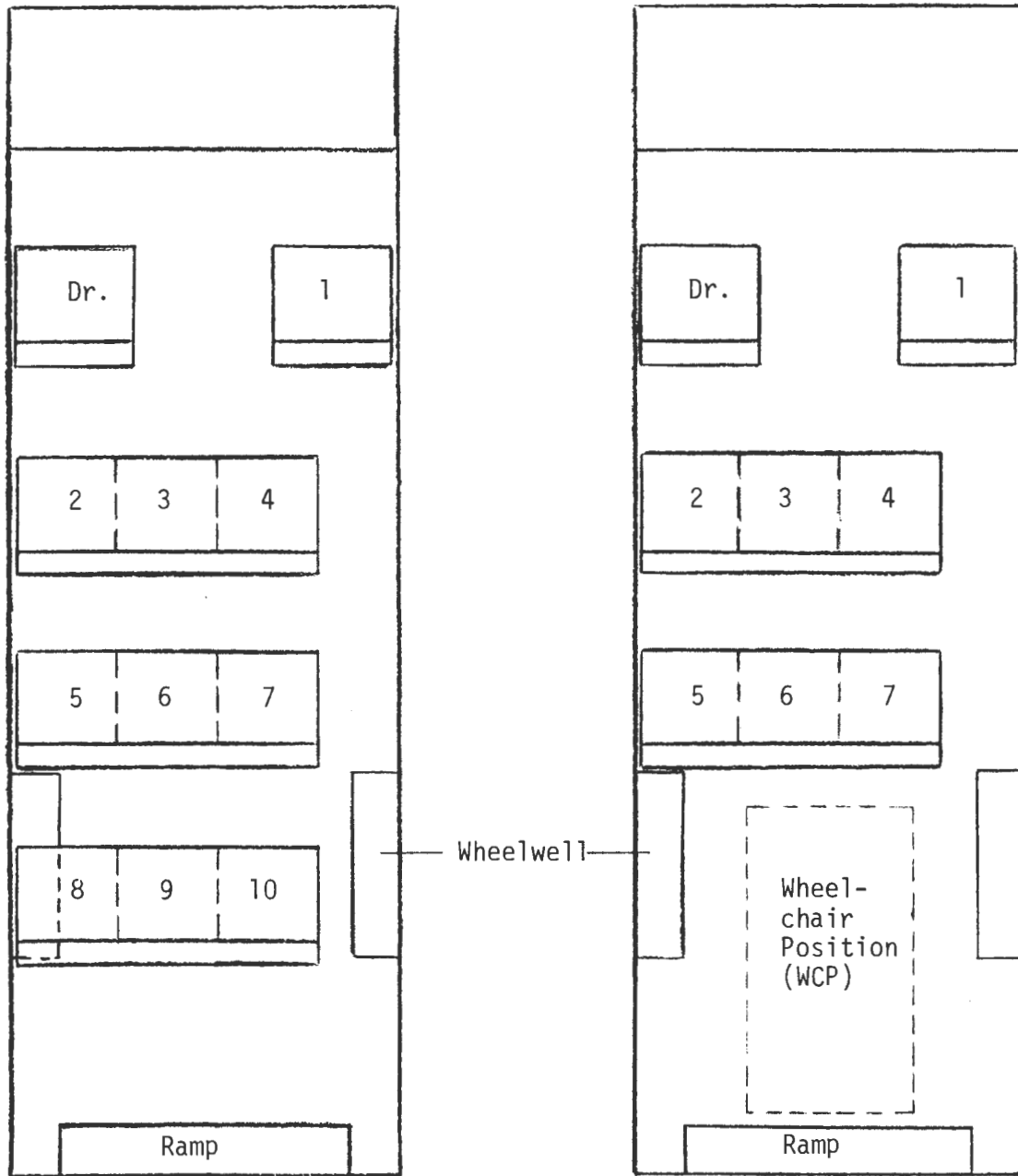

ILLUSTRATION 5 - STANDARD VAN REAR MOUNTED
RAMP OPERATION

Source: Elderly United of Springfield and Clark County

III-A-12

Available Floor Plans For Standard Van With Ramp
VB-10-1



Van with Rearmost Three-Passenger Bench Seat in Place

Seats: 1 Driver, 10 passengers, no wheelchairs

Van with Rearmost Three-Passenger Bench Seat Removed for One WCP

Seats: 1 Driver, 7 passengers, 1 wheelchair passenger

Note: Drawings show relative location of seats, wheelwell cover, lift and wheelchair position. Do not scale dimensions.

III-A. VAN SERIES
3. CONVERTED VANS

Converted Vans, Van Type "C"

Converted, or modified, vans are an attempt to improve the utility of the standard production van for transit use. As the name implies, these are standard production vans that have been altered to increase headroom, and may be made accessible to wheelchair passengers. The modifications are made by companies other than the original manufacturer.

Headroom is increased by actually removing the standard roof at or below the roof line and replacing it with a steel or fiberglass raised roof. This modification allows for a minimum floor to roof headroom of 72 inches. The interior of the vehicle is then redesigned with a front service entrance with extended door height, steps and any necessary reinforcement of the body frame. Insulation in the floor and side panels is installed, as well as floor covering. The van may be equipped with a wheelchair lift and one to three wheelchair positions. A wheelchair securement system is provided at each wheelchair position.

Some features you may expect to find on a Type "C" van are:

- Automatic transmission
- Power brakes
- Power steering
- Spare tire, jack and lug wrench
- More interior headroom than a standard passenger van
- Passenger service entry door with steps and standing headroom in doorway
- Wheelchair lift system including a lift, wheelchair securements and wheelchair occupant restraint system (optional)
- Seat belts
- Large outside mirrors
- Choice of manufacturer's standard colors

Any modification to a standard van may alter the structural integrity of the vehicle. However, with special attention to high quality materials and workmanship in producing these modifications, vehicle safety can be maintained. Procurement specifications written by ODOT for the purchase of the converted vans, as well as all other vehicles, are designed to help ensure that a high level of vehicle safety is maintained, and that quality workmanship and materials go into the production of these vehicles.

There are advantages and disadvantages of having a platform lift mounted at the vehicle side door or rear door. Rear mounted lifts may be better suited for rural operations where access to the curb side of the vehicle may be impractical due to roadside ditches, tall grass, heavy snow or narrow driveways. Rear mounted lifts may also be more accessible in areas where one-way streets restrict boarding from the side of the vehicle.

Side mounted lifts may be better suited to most urban applications where curb side passenger pickup is common. Also, side mounted lifts may eliminate some of the potential hazard of passenger injury in the event of a rear end collision while the lift is in operation. A rear end collision

can render a rear mounted lift inoperative, leaving passengers stranded on board.

As was stated earlier in this catalog, taking into consideration the comfort, as well as the safety, of all prospective passengers, it is the opinion of the Division of Public Transportation that all wheelchair lifts should be located in the side of the vehicles; and that requests for rear-mounted wheelchair lifts require special justification by the applicant. A rear-mounted wheelchair lift will not be approved without a written request to ODOT explaining the special justification. Furthermore, such a request must receive approval of the Division of Public Transportation's Engineering staff before the request will be granted.

Regardless of where the lift is mounted, it should be remembered that maneuverability of a wheelchair inside a vehicle is extremely restricted. As a rule, the first wheelchair on the vehicle will be the last one off. This should be taken into account when planning the passenger pickup and delivery schedule. If not carefully planned, the driver will waste time loading and unloading passengers several times.

On those vehicles with a wheelchair lift, a jump seat option may be selected. The jump seat option will provide fold-down seats at the wheelchair positions (WCPs) for use when the WCPs are not occupied by a wheelchair. The use of the jump seats will increase the seating capacity of the vehicle when the WCPs are not in use. The number of jump seat positions to be provided with each floor plan option is shown in the "Vehicles Available" table.

Ancillary equipment for this category of vehicles is listed below. Illustrations showing converted vans, with lifts, and the available floor plans for this series are shown on the following pages. Descriptive material for the ancillary equipment is shown in Section IV. Cost Estimates are given in Section V, a separately published supplement.

Vehicle Category: Van, Type C

Vehicles Available:

<u>Vehicle Designation</u> ⁽¹⁾	<u>Adult Seating</u> ⁽²⁾	<u>Lift Provided?</u>	<u>Lift Location</u>	<u>Number of WCPs</u> ⁽³⁾	<u>JSPs</u> ⁽⁴⁾	
					<u>Opt. 1</u>	<u>Opt. 2</u>
VC-13-0	13	No	N/A	0	0	0
VCS-10-1	10	Yes	Side	1	1	1
VCS-8-2	8	Yes	Side	2	2	2
VCS-6-3	6	Yes	Side	3	4	3
VCR-10-1	10	Yes	Rear	1	1	1
VCR-8-2	8	Yes	Rear	2	1	3
VCR-6-3	6	Yes	Rear	3	3	4

- Notes:
- (1) Two optional floor plans (at no additional cost to the agency) will be available for each vehicle designated.
 - (2) Regular Adult Passenger Seating Capacity (the driver is not included in this total nor are jump seat positions).
 - (3) WCPs = Wheelchair Positions provided on vehicle.
JSPs = Jump Seat Positions.
 - (4) This column indicates the number of jump seat positions that will be provided for each floor plan option if the Jump Seat Option is chosen. Jump seat locations are shown on the floor plan drawings.

Colors Available:

The colors listed below are generic colors available in the Van "C" series. Please indicate on the application the color desired for your vehicle. The purchase order, written after the make of the vehicle is determined via the bidding process, will specify the brand-name color most closely matching the generic color chosen.

- | | |
|----------------------|---------------|
| 1. White | 6. Dark Brown |
| 2. Black | 7. Light Blue |
| 3. Red | 8. Dark Blue |
| 4. Beige (Off-White) | 9. Grey |
| 5. Tan (Light Brown) | 10. Silver |

Floor Plan Option:

Two floor plan options are offered for each of the vehicles designated in this series. Once the decision is made by the agency as to whether or not a wheelchair lift is desired and where the lift is to be located (side or rear), either floor plan option (option #1 or option #2) offered for each vehicle designation (e.g., VCS-6-3) can be selected by the agency. Drawings of all floor plan options are shown following the text of this section. Option #1 is primarily a forward facing arrangement of the seats while option #2 is primarily a perimeter seating arrangement.

The agency must list on the application the desired floor plan option.

Ancillary Equipment (Provided):

The following equipment will be specified for each vehicle and no additional action is required by the agency.

1. Automatic Transmission
2. Power Steering and Power Brakes
3. Large Engine Size - Minimum 350 cubic inch (5.74 liter) engine displacement

4. Heavy-duty Equipment (cooling system, springs and shock absorbers)
5. Extra-Large Battery with a total capacity of at least 85 amp-hours
6. Large Alternator with a minimum capacity of 100 amps
7. Large Fuel Tank (total capacity of at least 33 U.S. gallons)
8. Rear Auxiliary Heater
9. Tinted Glass in Windshield and all Windows
10. Emergency Equipment
11. Undercoating
12. Rustproofing

Ancillary Equipment (Optional):

The following equipment is available for each vehicle as an option. The agency must specify in its application what options are desired. These options will cost extra and estimated prices are given in Section V, a separately published supplement.

1. Wheelchair Lift (includes wheelchair securement system and wheelchair occupant restraint system)
2. Jump Seat (fold-down seats at a wheelchair position to provide regular seating when wheelchairs are not present)
3. Air Conditioning (front and rear)
4. Radial Tires
5. Two-way FM Radio (VHF-low, VHF-high or UHF band) Mobile Units
6. Driver Hand Controls (for operation of the vehicle)
7. Wheelchair Accessibility Symbol (on outside of vehicle)

Unavailable Ancillary Equipment:

The following equipment is not available through this program and should not be requested.

1. Wheelchair ramp (instead of wheelchair lift)
2. Overhead flashing lights
3. Running Boards
4. Luggage Rack
5. Logos painted on the side of the vehicle
6. CB radio, commercial band radio, or tape player
7. Special or fancy wheelcovers
8. Special paint job

sPT20E



ILLUSTRATION 6: CONVERTED VAN WITHOUT A LIFT

Source: Coach and Equipment Sales Corporation (Fortivan)

III-A-19



ILLUSTRATION 7: CONVERTED VAN WITH SIDE MOUNTED WHEELCHAIR LIFT

Source: Bud Industries, Inc.

III-A-20



ILLUSTRATION 8: CONVERTED VAN WITH SIDE MOUNTED WHEELCHAIR LIFT

Source: National Coach Corp.

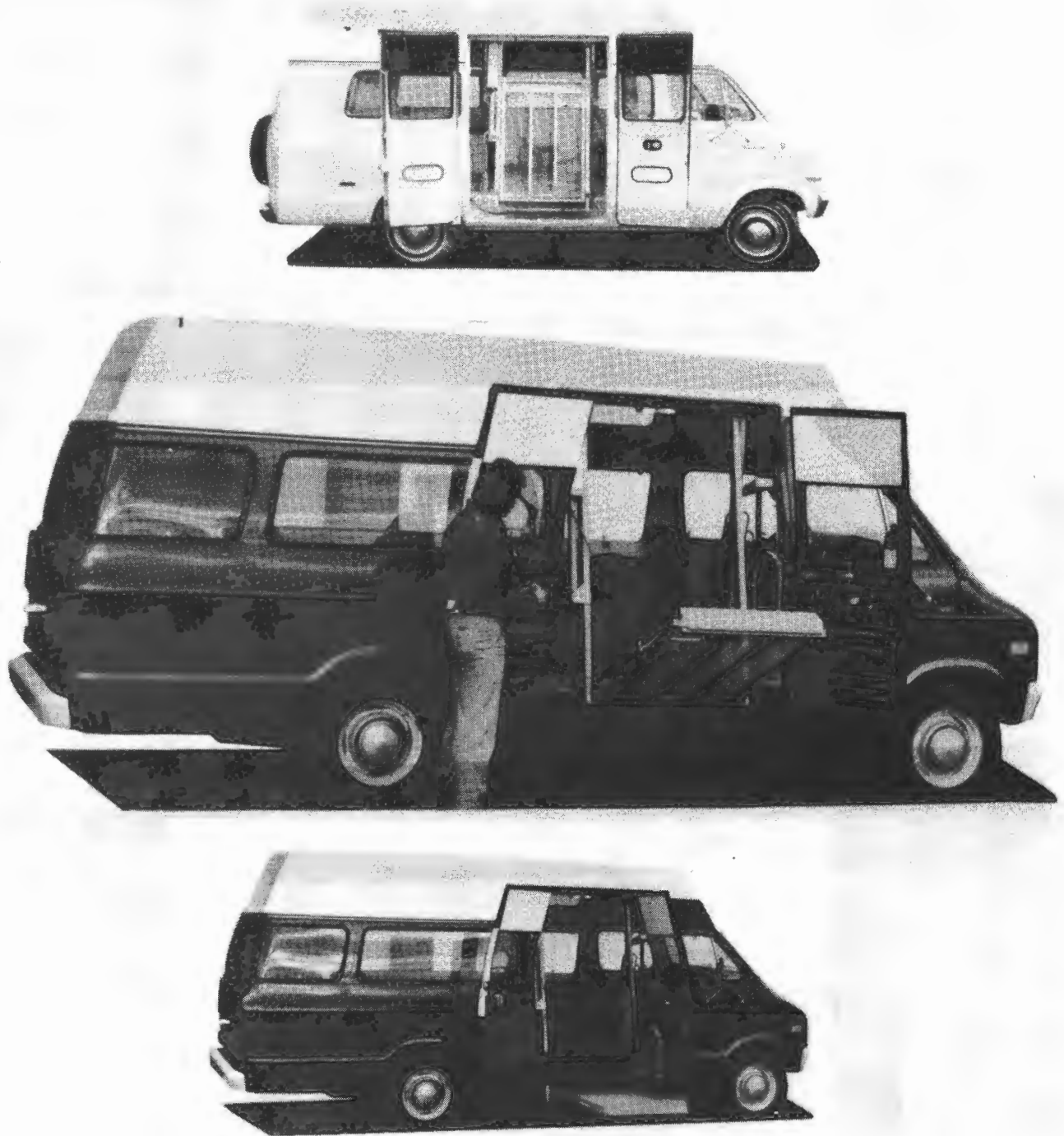

ILLUSTRATION 9: CONVERTED VAN SHOWING OPERATION OF
SIDE MOUNTED WHEELCHAIR LIFT

Source: The Braun Corporation



ILLUSTRATION 10: CONVERTED VAN SHOWING OPERATION OF
SIDE MOUNTED WHEELCHAIR LIFT

Source: Coach and Equipment Sales Corporation (Fortivan)



ILLUSTRATION 11: CONVERTED VAN WITH
REAR MOUNTED WHEELCHAIR LIFT

Source: Toledo Society for the Handicapped

III-A-24



ILLUSTRATION 12 - CONVERTED VAN INTERIOR

Source: The Braun Corp.



III-A-25

ILLUSTRATION 13: INTERIOR OF CONVERTED VAN

Source: Bud Industries

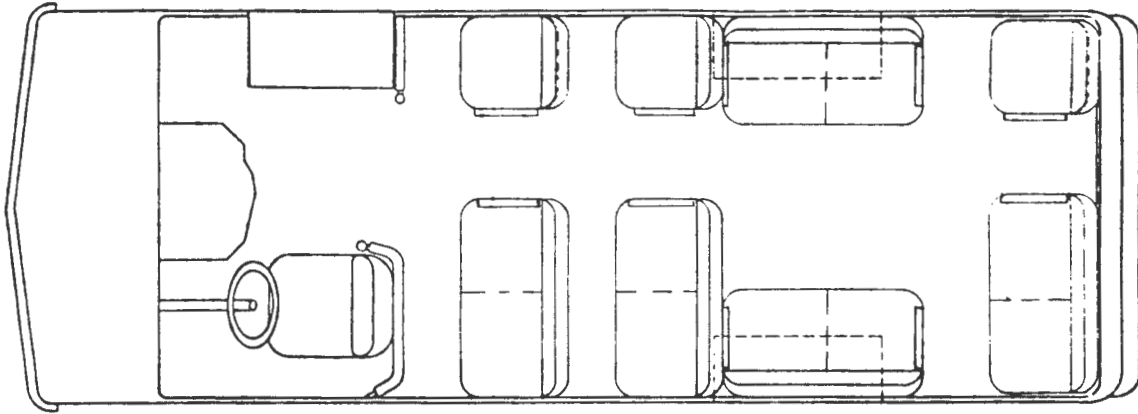

ILLUSTRATION 14 - INTERIOR ON CONVERTED VAN
SHOWING FIRST STEP

Source: Collins Industries

AVAILABLE FLOOR PLANS
(Converted Vans)

VC-13-0 (Option #1)



VC-13-0 (Option #2)

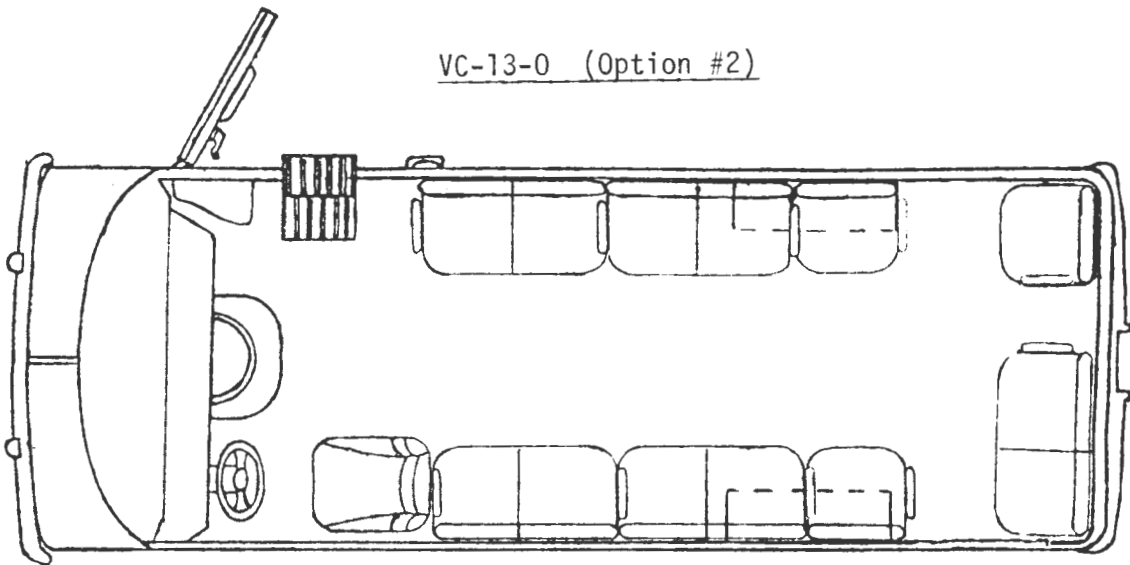

AVAILABLE FLOOR PLANS
(Converted Vans)

VCS-10-1 (Option #1)

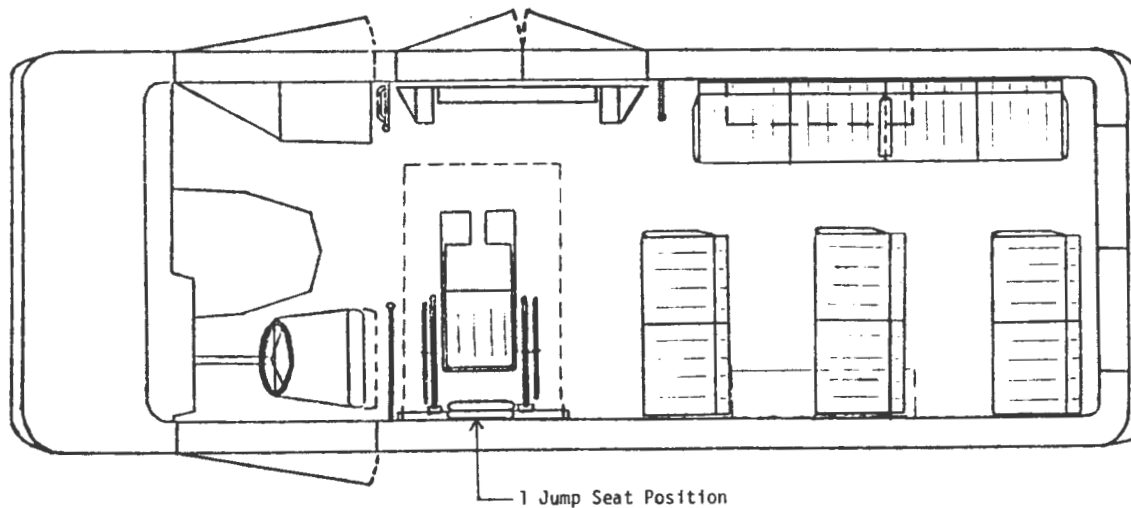

VCS-10-1 (Option #2)

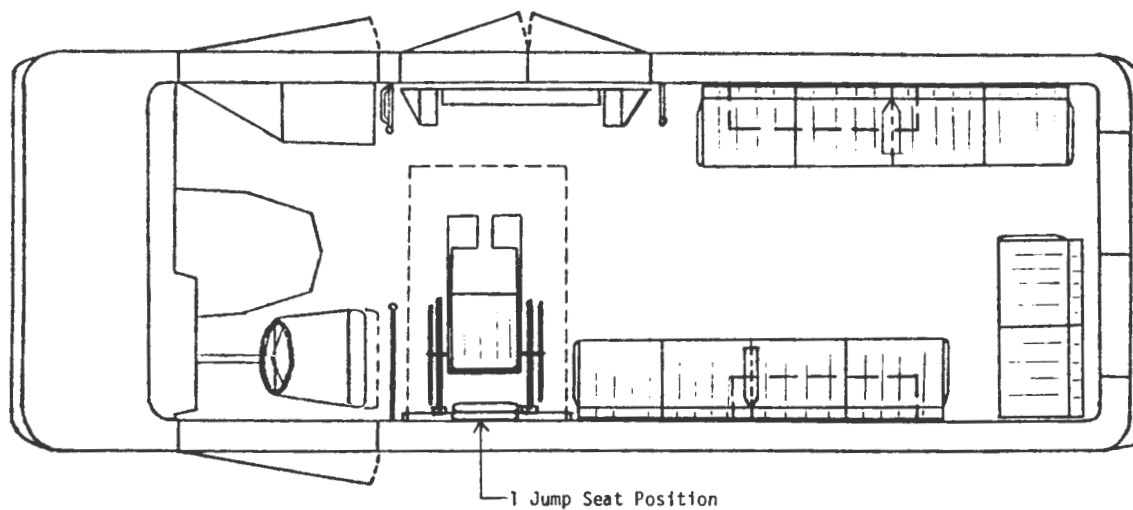

AVAILABLE FLOOR PLANS
(Converted Vans)

VCS-8-2 (Option #1)

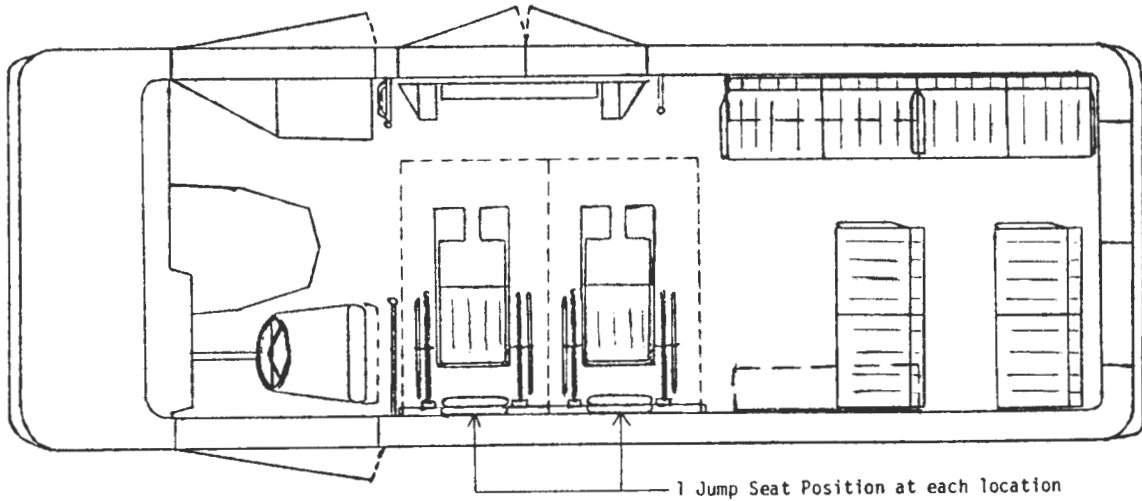

VCS-8-2 (Option #2)

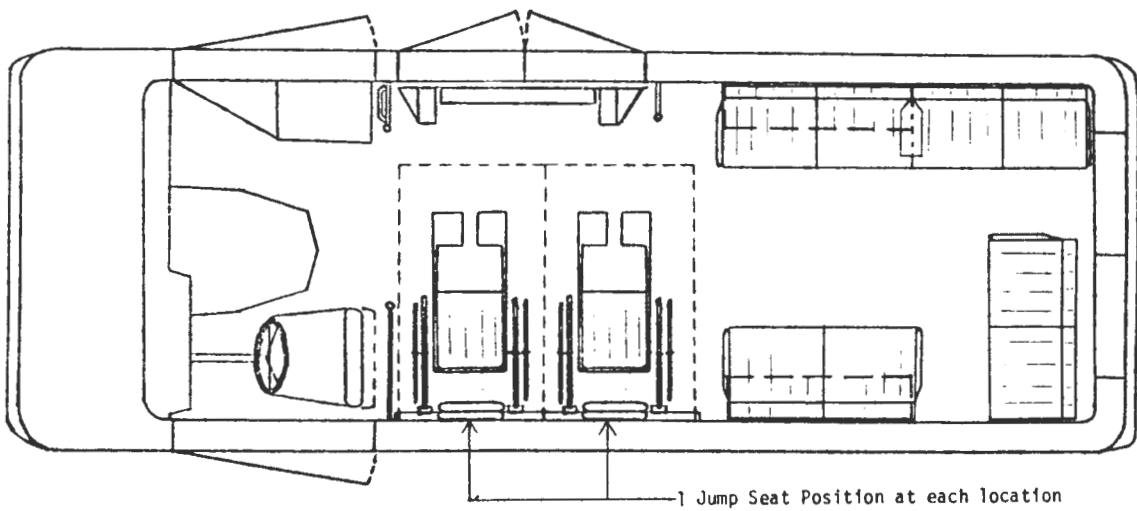

AVAILABLE FLOOR PLANS
(Converted Vans)

VCS-6-3 (Option #1)

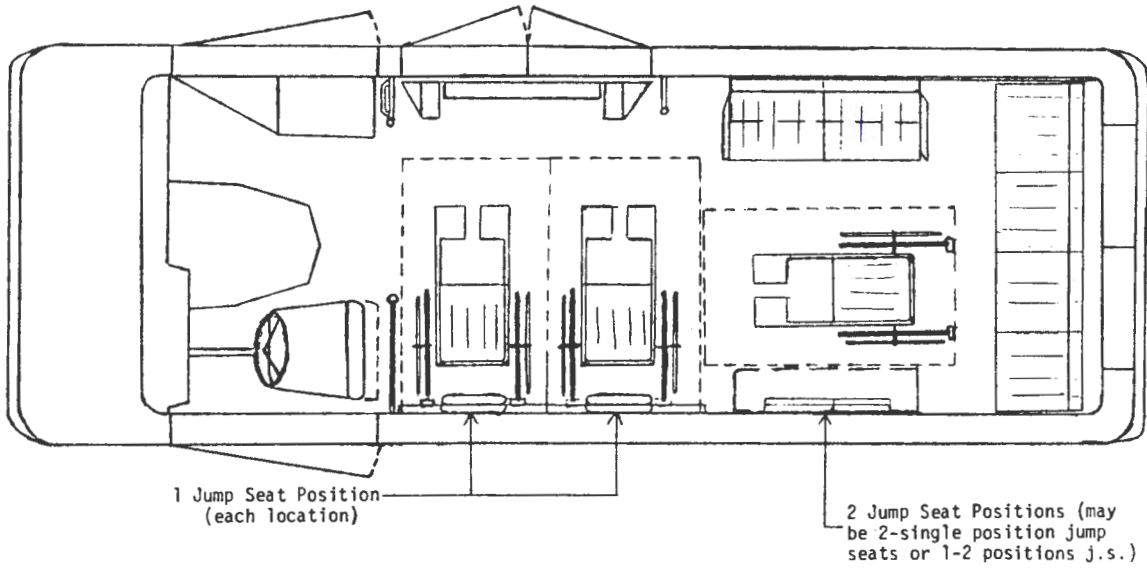

VCS-6-3 (Option #2)

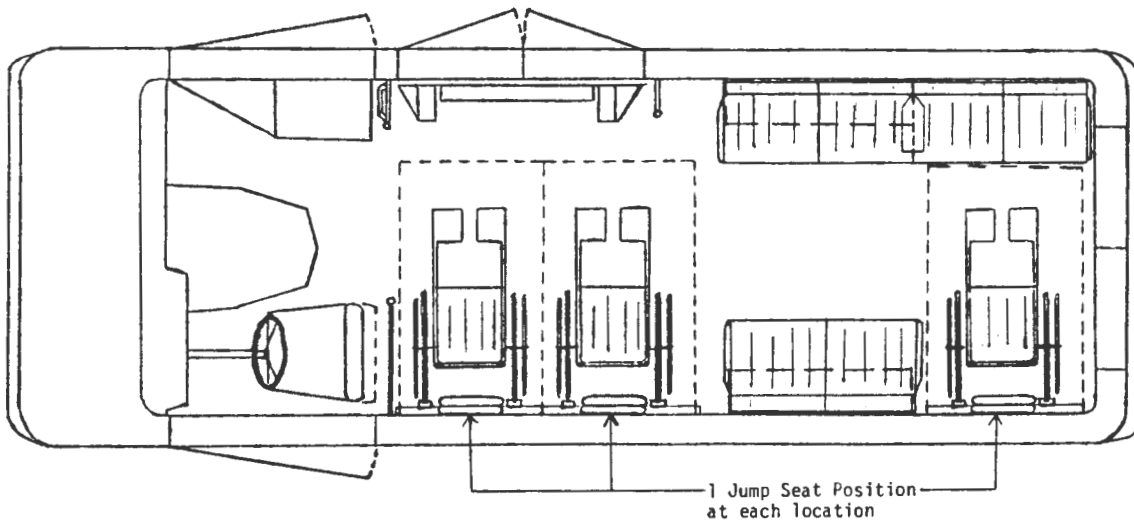

AVAILABLE FLOOR PLANS
(Converted Vans)

VCR-10-1 (Option #1)

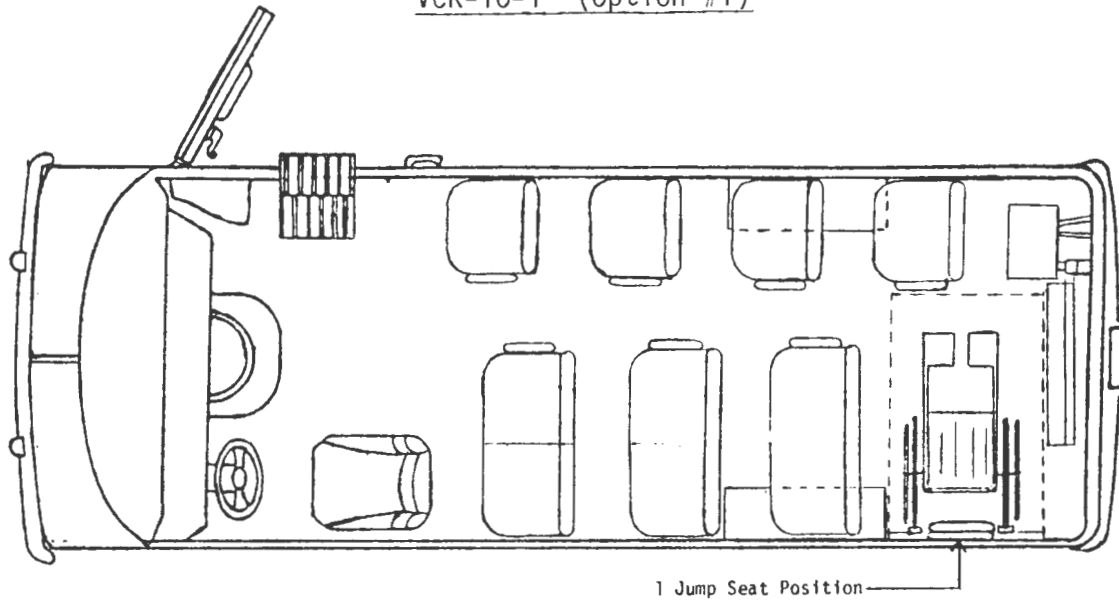

VCR-10-1 (Option #2)

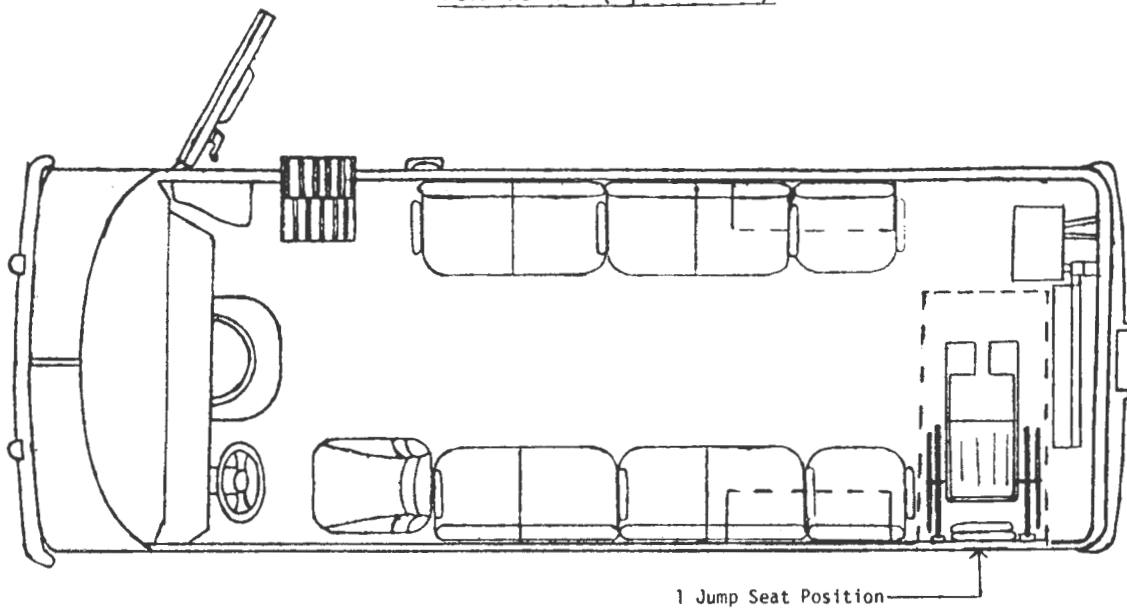

AVAILABLE FLOOR PLANS
(Converted Vans)

VCR-8-2 (Option #1)

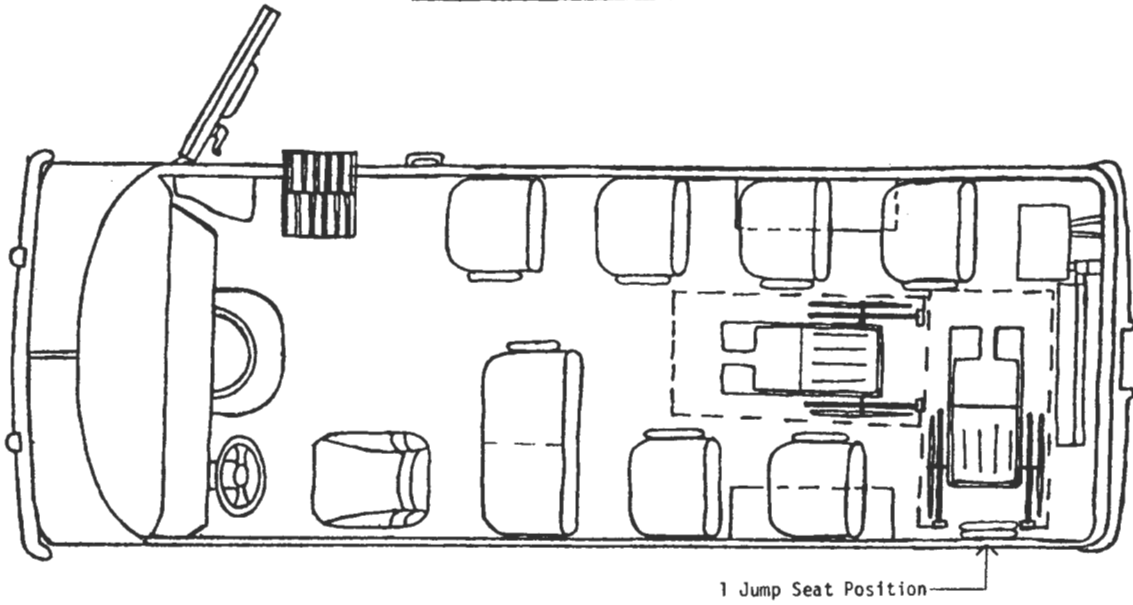

VCR-8-2 (Option #2)

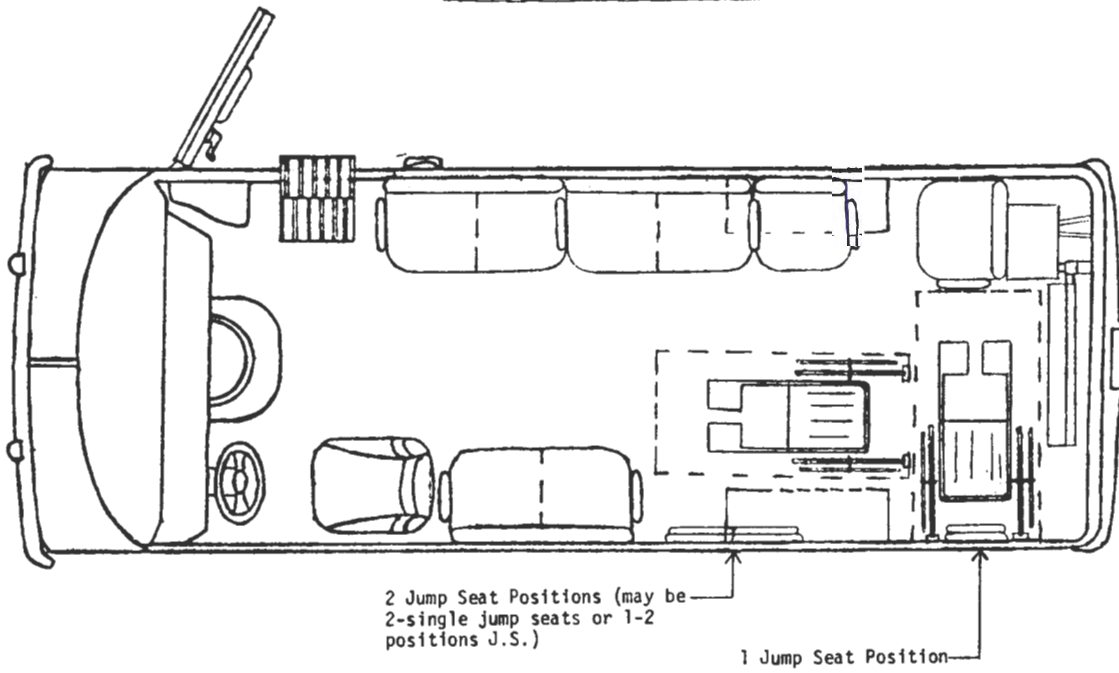

AVAILABLE FLOOR PLANS
(Converted Vans)

VCR-6-3 (Option #1)

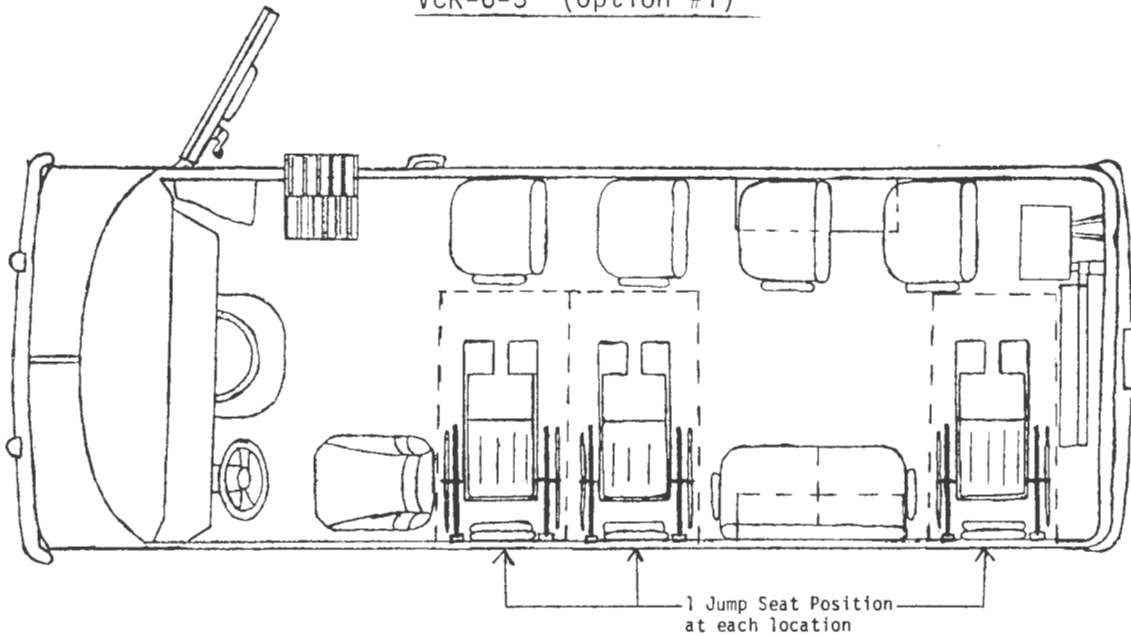

VCR-6-3 (Option #2)

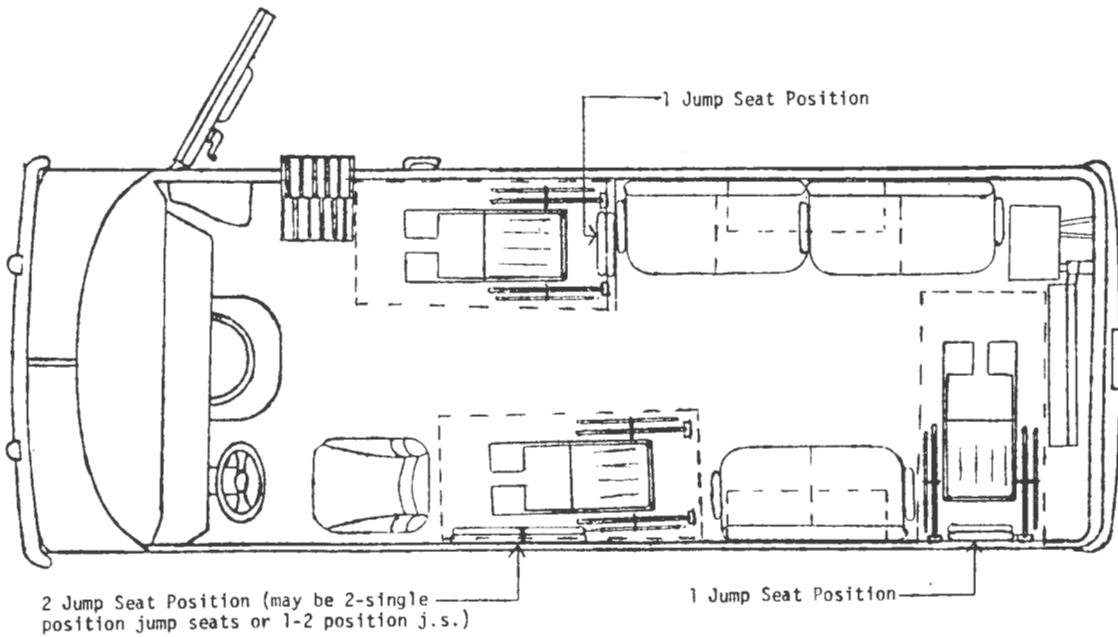

III-B. LIGHT TRANSIT VEHICLE SERIES

TABLE OF CONTENTS - SECTION III-B

	<u>Page</u>
III. <u>TYPES OF VEHICLES AVAILABLE - B. Light</u>	
<u>Transit Vehicle Series</u>	III-B-1
a. Illustration 15 - Collins Omni Bus (Modified Van) . .	III-B-6
b. Illustration 16 - Wayne Transette (Body on Conventional Chassis)	III-B-7
c. Illustration 17 - Wayne Transette with Wheelchair Lift (Body on Conventional Chassis)	III-B-8
d. Illustration 18 - National Escort II (Body on Conventional Chassis)	III-B-9
e. Illustration 19 - National Escort II (Body on Conventional Chassis)	III-B-10
f. Illustration 20 - Premiere Commuter III (Body on Conventional Chassis)	III-B-11
g. Illustration 21 - Fortibus with Wheelchair Lift (Body on Conventional Chassis)	III-B-12
h. Illustration 22 - Terravan Transit Van (Body on Conventional Chassis)	III-B-13
i. Illustration 23 - H.C.I. Transporter (Body on Conventional Chassis)	III-B-14
j. Illustration 24 - Falcon People Mover (Laminated Honeycomb Fiberglass)	III-B-15
k. Illustration 25 - Diamond People Mover (Laminated Honeycomb Fiberglass)	III-B-16
l. Illustration 26 - Diamond People Mover with Wheelchair Lift (Laminated Honey- comb Fiberglass)	III-B-17
m. Illustration 27 - Interior Views of Light Transit Vehicles	III-B-18
n. Available Floor Plans for Light Transit Vehicles	III-B-19

Light Transit Vehicles, LTV

Light transit vehicles may be classified in two types according to the general method of construction. The first vehicle type is a "Modified Van" which involves modifying a large standard passenger van by replacing the existing roof and sides with new construction, thereby achieving greater interior height (73" minimum) and width (74" minimum) and by adding a transit type passenger service entry door. The second vehicle type is "Body on Chassis" which involves construction of a bus body on a heavy duty cut-away van chassis or a light duty truck chassis. The minimum interior dimensions for Type 2 vehicles are 73" headroom and 85"± width. A more detailed description of each type follows:

Modified Van (Type 1). This type of light transit vehicle is very similar to the Van "C" except that the method of modification and the height of the roof extension provides a greater interior width at window level (74" in the LTV vs. 68"± in the Van "C") and greater headroom (73" in the LTV vs. 72" in the Van "C"). Also, the roof of the LTV must be constructed of steel while that of the Van "C" may be steel, aluminum or fiberglass. An example of this type of vehicle is the Collins Omnibus.

Body on Chassis (Type 2). This type of light transit vehicle has two main components - a body and a chassis. The LTV manufacturer adds a vehicle body to a conventional "Detroit type" chassis. The body construction may be of either of the following methods:

- (1) Conventional (Type 2, Method 1). This method involves attaching panels (metal or fiberglass) to a structural steel frame. Construction is similar to that of school buses. However, standard or modified school buses are not permitted to be bid in the LTV series.

Examples of this type of vehicle are the Wayne Transette, Coach and Equipment Fortibus, HCI Transporter, Turtle Top Terravan, National Escort II, and Premiere Commuter III.

- (2) Laminated Honeycomb Fiberglass (Type 2, Method 2). This method involves fastening structural sandwich panels, together to form a complete integrated body unit. No structural steel frame is involved. The panels are of honeycomb core material sandwiched between fiberglass sheets. This method of construction has been used in the aircraft industry for years to construct airplane bodies.

Examples of this type of vehicle are the El Dorado Falcon People Mover and the Coons Diamond People Mover.

Some features you may expect on a light transit vehicle, such as described above, are:

- Automatic transmission
- Power brakes
- Power steering
- Spare tire, jack and lug wrench
- Greater headroom than a standard or converted van
- Greater interior width than a standard or converted van
- Transit type passenger service door with standing headroom in the doorway
- Lower steps
- Seat belts
- Large outside mirrors
- Choice of manufacturer's standard colors
- Optional wheelchair transporting capability

The extended interior width (74" min. for type 1 and 85" min. for type 2) gives more maneuverability within the vehicle and can more easily accommodate wheelchairs than converted vans (Van "C"). Also, the added interior width allows greater ease in accessing seats which should be a major consideration when transporting elderly persons or persons with severe mobility limitations.

The LTV series of vehicles offers a greater variety of interior options and seating arrangements than standard or converted vans or buses. However, a "rear of the vehicle" location of the wheelchair lift is not available in this series and should not be requested, even if the agency believes it has sufficient justification for a rear-mounted lift. A rear-mounted lift, if properly justified, may be requested on a Van "C" vehicle.

On these vehicles with a wheelchair lift, a jump seat option may be selected. The jump seat option will provide fold-down seats at the wheelchair positions (WCPs) for use when the WCPs are not occupied by a wheelchair. The use of the jump seats will increase the seating capacity of the vehicle when the WCPs are not in use. The number of jump seat positions to be provided with each floor plan option is shown in the "Vehicles Available" table.

Ancillary equipment for these types of vehicles are listed below. Illustrations showing various types of LTV vehicles, with and without lifts, and the available floor plans for this series are shown on the following pages. Descriptive material for ancillary equipment is shown in Section IV. Cost Estimates are given in Section V, a separately published supplement.

Vehicle Series: Light Transit Vehicle (LTV)

Vehicles Available:

<u>Vehicle Designation</u>	<u>Adult Seating⁽¹⁾</u>	<u>Lift Provided?</u>	<u>Number of WCPs⁽²⁾</u>	<u>JSPs⁽³⁾</u>	
				<u>Opt. 1</u>	<u>Opt. 2</u>
LTV-25-0	25	No	0	0	N.A.
LTV-19-1	19	Yes	1	1	N.A.
LTV-17-2	17	Yes	2	2	N.A.
LTV-15-3	15	Yes	3	3	N.A.
LTV-11-4	11	Yes	4	4	N.A.
LTV-21-0	21	No	0	0	N.A.
LTV-15-1	15	Yes	1	1	N.A.
LTV-13-2	13	Yes	2	2	N.A.
LTV-11-3	11	Yes	3	3	N.A.
LTV-17-0	17	No	0	0	N.A.
LTV-11-1	11	Yes	1	1	N.A.
LTV- 9-2	9	Yes	2	2	N.A.
LTV- 7-3	7	Yes	3	4	N.A.
LTV-14-0*	14	No	0	0	0
LTV-10-1*	10	Yes	1	1	1
LTV- 8-2*	8	Yes	2	2	2
LTV- 6-3*	6	Yes	3	4	3

Notes: *Two optional floor plans will be available for each vehicle designation marked with an asterisk.

N.A. - A second optional floor plan is not available.

- (1) Regular Adult Seating Capacity (the driver is not included in this total nor are the jump seat positions).
- (2) WCPs = Wheelchair Positions provided on vehicle.
- (3) JSPs = Jump Seat Positions. This column indicates the number of jump seat positions that will be provided for each floor plan option if the Jump Seat Option is chosen. Jump seat locations are shown on the floor plan drawings.

Colors Available:

The colors listed below are generic colors available in the LTV series. Please indicate on the application the color desired for your vehicle. The purchase order, written after the make of the vehicle is determined via the bidding process, will specify the brand-name color most closely matching the generic color chosen.

- | | |
|----------------------|---------------|
| 1. White | 6. Dark Brown |
| 2. Black | 7. Light Blue |
| 3. Red | 8. Dark Blue |
| 4. Beige (Off-White) | 9. Dark Green |
| 5. Tan (Light Brown) | 10. Silver |

Floor Plans Available:

Drawings of all floor plans that are available in the LTV series are shown following the text of this section. Two floor plan options are offered for the 14 passenger size vehicle series; and either may be selected by the agency. Option #1 is primarily a forward facing seating arrangement of the seats while option #2 is primarily a perimeter seating arrangement. Only one floor plan option is offered for the longer (25, 21 and 17 passenger size series) vehicles. However, size LTV-11-3 does show two possible floor plan layouts, according to which vehicle is awarded the bid.

The agency must list on the application the desired floor plan. For the larger vehicles, as described in the preceding paragraph, list option #1, since that is all that is available, and for the 14 passenger size series list either option #1 or option #2.

Ancillary Equipment (Provided):

The following equipment will be provided for each vehicle and no additional action is required by the agency.

1. Automatic Transmission
2. Power Steering and Brakes
3. Eight Cylinder Gasoline Engine with a minimum engine displacement of 350 cubic inches (5.74 liter)
4. Heavy-duty Equipment (cooling system, springs and shock absorbers)
5. Extra-Large Battery
 - a. Type 1 Vehicle, at least 85 amp-hour capacity
 - b. Type 2 Vehicle, at least 150 amp-hour capacity
6. Large Alternator
 - a. Type 1 Vehicle, a minimum capacity of at least 100 amps
 - b. Type 2 Vehicle, a minimum capacity of at least 130 amps
7. Large Fuel Tank (total capacity of at least 30 U.S. gallons)
8. Rear Auxiliary Heater
9. Tinted Glass in Windshield and all Windows
10. Emergency Equipment
11. Undercoating
12. Rustproofing
13. Seat Belts (driver and all passengers)
14. Left and Right Hand Outside Mirrors with Spot Mirrors

Ancillary Equipment (Optional):

The following equipment is available for each vehicle as an option. The agency must specify in its application what options are desired. These

options will cost extra, and estimated prices are given in Section V, a separately published supplement.

1. Wheelchair Lift (includes wheelchair securement system and wheelchair occupant restraint system)
2. Jump Seat (fold-down seats at a wheelchair position to provide regular seating when wheelchairs are not present)
3. Custom Seats (deluxe passenger seats)
4. Air Conditioning (front and rear)
5. Radial Tires
6. Two-way FM Radio (VHF-low, VHF-high or UHF band) Mobile Units
7. Driver Hand Controls (for operation of the vehicle)
8. Wheelchair Accessibility Symbol (on outside of vehicle)

Unavailable Ancillary Equipment:

The following equipment is not available through this program and should not be requested.

1. Wheelchair ramp (instead of a wheelchair lift)
2. Rear-mounted wheelchair lift
3. Overhead flashing lights
4. Luggage Rack (interior or exterior)
5. Logos painted on the side of the vehicle
6. CB radio, commercial band radio, or tape player
7. Special or fancy wheelcovers
8. Special paint job

bPT20F

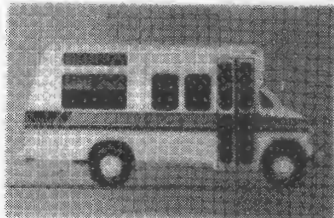

ILLUSTRATION 15 - LIGHT TRANSIT VEHICLE
(MODIFIED VAN)
- COLLINS OMNI BUS

Source: Collins Industries, Inc.

III-B-7



ILLUSTRATION 16 - LIGHT TRANSIT VEHICLE
(BODY ON CONVENTIONAL CHASSIS)
- WAYNE TRANSETTE

Source: Wayne Corporation



ILLUSTRATION 17 - LIGHT TRANSIT VEHICLE
(BODY ON CONVENTIONAL CHASSIS)
- WAYNE TRANSETTE WITH
WHEELCHAIR LIFT

Source: Wayne Corporation



ILLUSTRATION 18 - LIGHT TRANSIT VEHICLE
(BODY ON CONVENTIONAL CHASSIS)
NATIONAL ESCORT II

Source: National Coach Corp.



ILLUSTRATION 19 - LIGHT TRANSIT VEHICLE
(BODY ON CONVENTIONAL CHASSIS)

NATIONAL ESCORT II

Source: National Coach Corp.

III-B-11



ILLUSTRATION 20 - LIGHT TRANSIT VEHICLE
(BODY ON CONVENTIONAL CHASSIS)
PREMIERE COMMUTER III

Source: Premiere Bus Manufacturing Co.

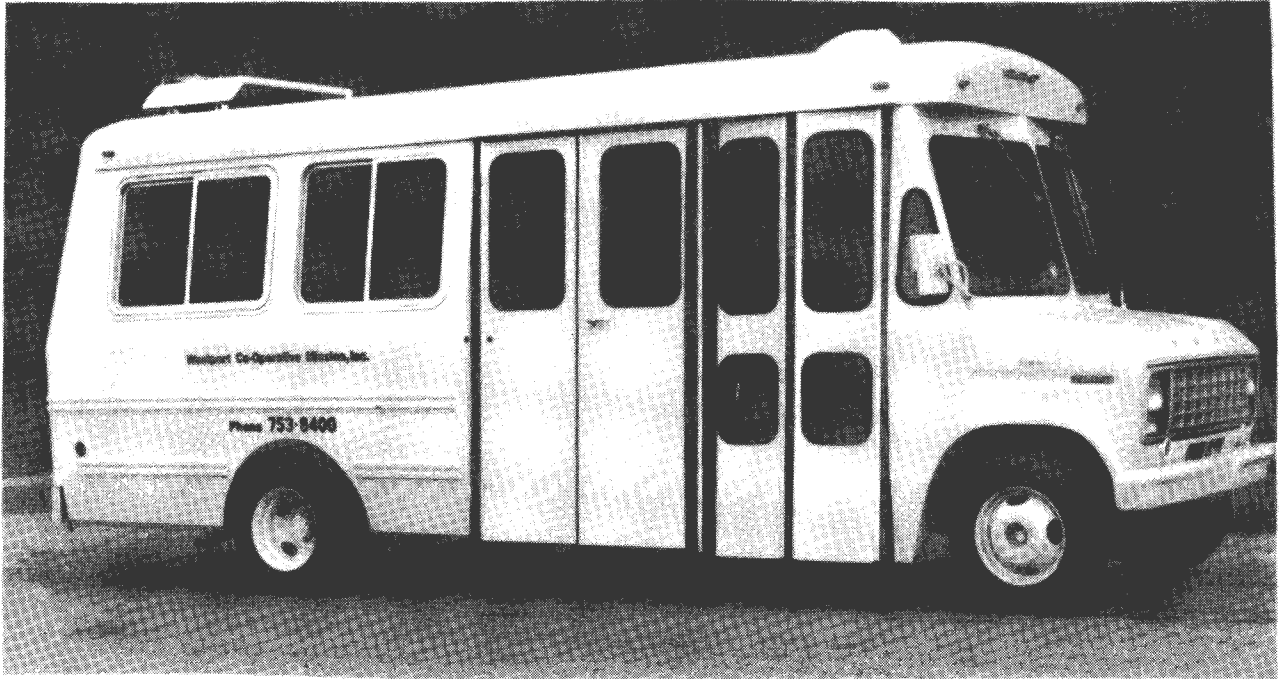

ILLUSTRATION 21 - LIGHT TRANSIT VEHICLE
(BODY ON CONVENTIONAL CHASSIS)
- FORTIBUS WITH WHEELCHAIR LIFT

Source: Coach and Equipment Sales Corporation

111-B-13



ILLUSTRATION 22 - LIGHT TRANSIT VEHICLE
(BODY ON CONVENTIONAL CHASSIS)
- TERRAVAN TRANSIT VAN

Source: Turtle Top, Inc.



ILLUSTRATION 23 - LIGHT TRANSIT VEHICLE
(BODY ON CONVENTIONAL CHASSIS)
- H.C.I. TRANSPORTER

Source: Handicap Conversions, Inc.



ILLUSTRATION 24 - LIGHT TRANSIT VEHICLE
(LAMINATED HONEYCOMB FIBERGLASS)
FALCON PEOPLE MOVER

Source: Clermont Authority for Rural Transportation



ILLUSTRATION 25 - LIGHT TRANSIT VEHICLE
(LAMINATED HONEYCOMB FIBERGLASS)
- DIAMOND PEOPLE MOVER

Source: Coons Manufacturing Inc.

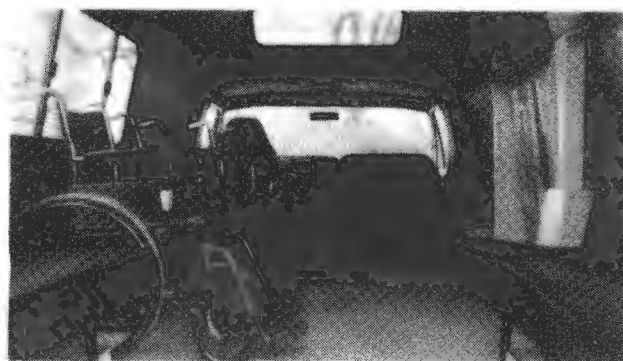

ILLUSTRATION 26 - LIGHT TRANSIT VEHICLE
(LAMINATED HONEYCOMB FIBERGLASS)
- DIAMOND PEOPLE MOVER
WITH WHEELCHAIR LIFT

Source: Coons Manufacturing Inc.



MINIMUM SEATING THAT MEETS SPECIFICATIONS



TYPICAL SEATING

ILLUSTRATION 27 - INTERIOR VIEWS OF LIGHT
TRANSIT VEHICLES

AVAILABLE FLOOR PLANS
(Light Transit Vehicles)

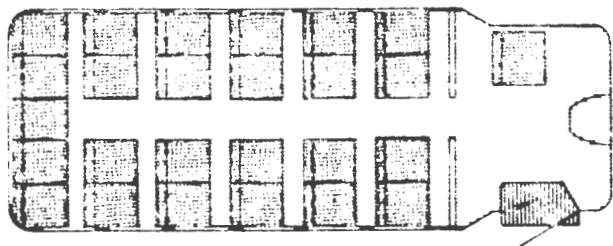

LTV-25-0

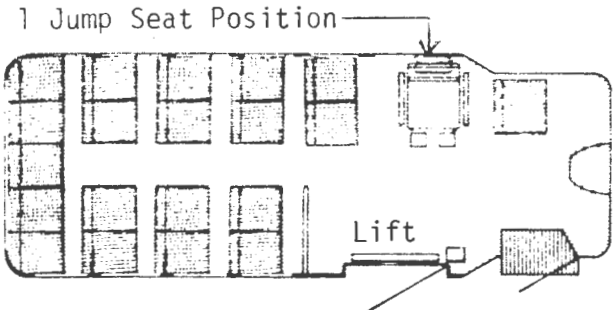

LTV-19-1

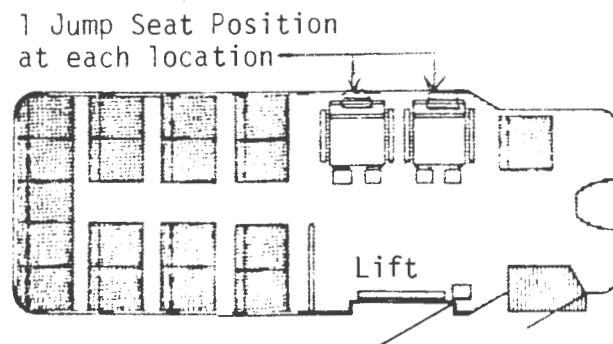

LTV-17-2

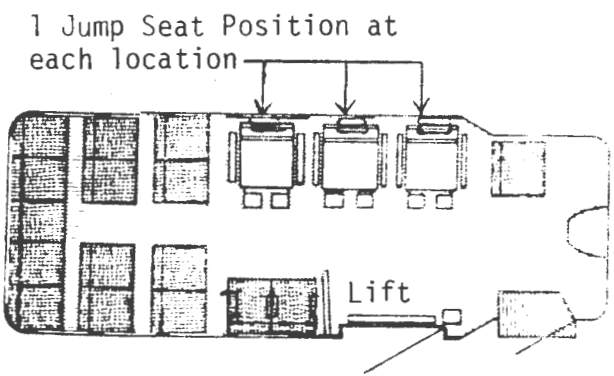

LTV-15-3

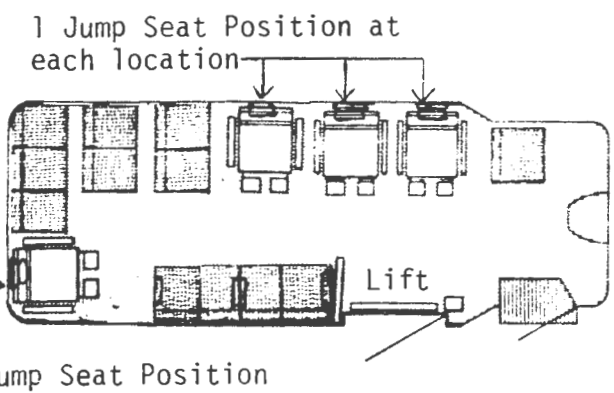

LTV-11-4

III-B-19

AVAILABLE FLOOR PLANS
(Light Transit Vehicles)

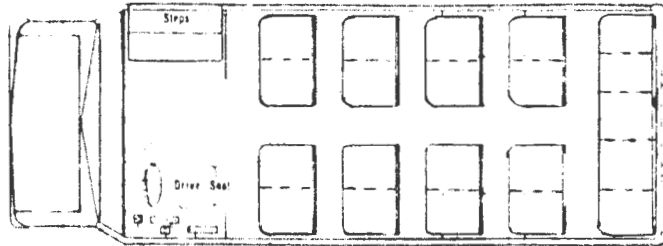

LTV-21-0

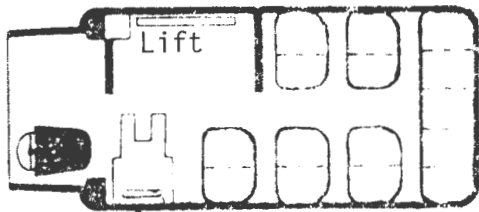

1 Jump Seat Position

LTV-15-1

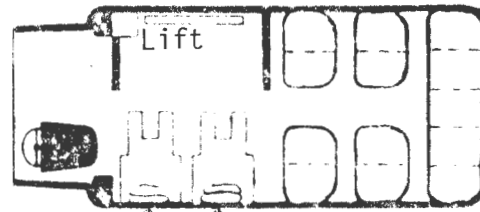

1 Jump Seat Position
at each location

LTV-13-2

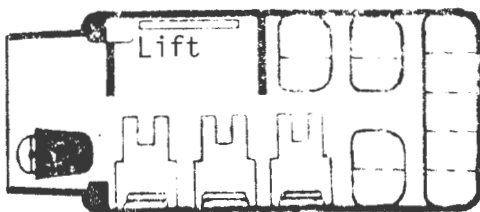

1 Jump Seat
Position at
each location

LTV-11-3

OR

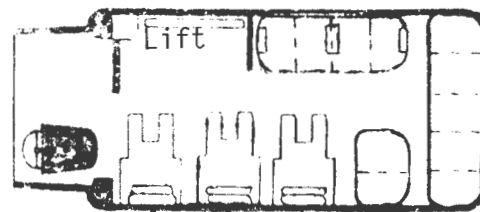

1 Jump Seat Position
at each location

LTV-11-3

AVAILABLE FLOOR PLANS
(Light Transit Vehicles)

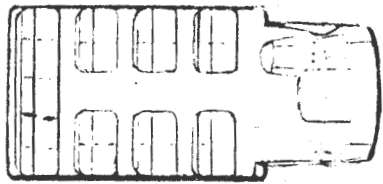

LTV-17-0

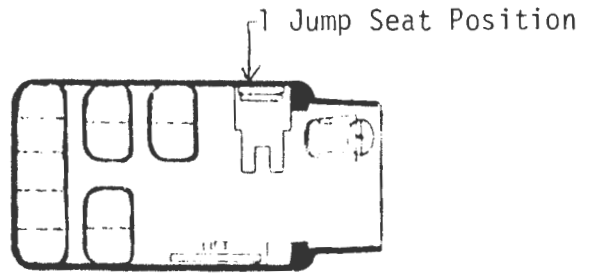

LTV-11-1

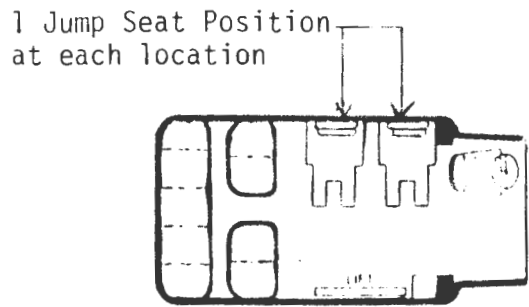

LTV-9-2

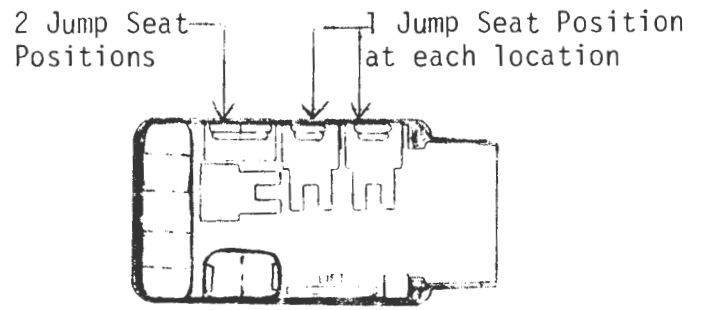

LTV-7-3

AVAILABLE FLOOR PLANS
(Light Transit Vehicles)

LTV-14-0
(OPTION #1)

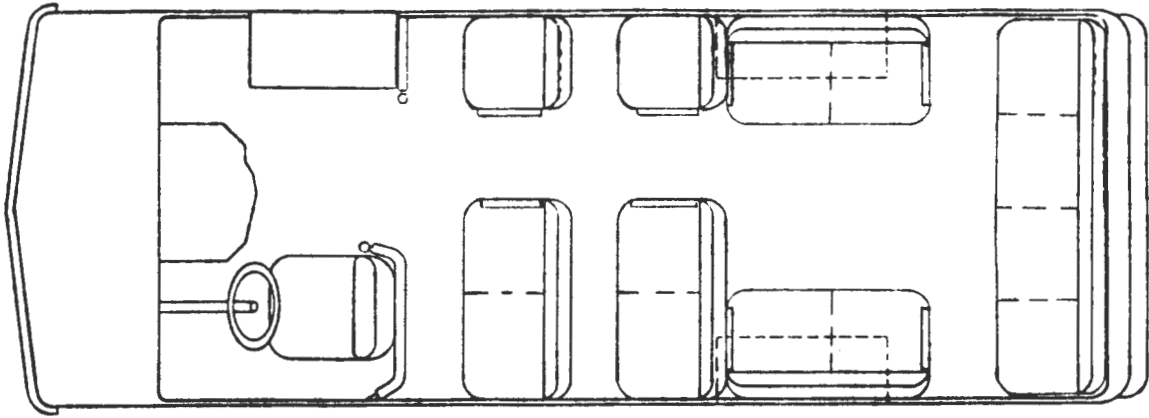

LTV-14-0
(OPTION #2)

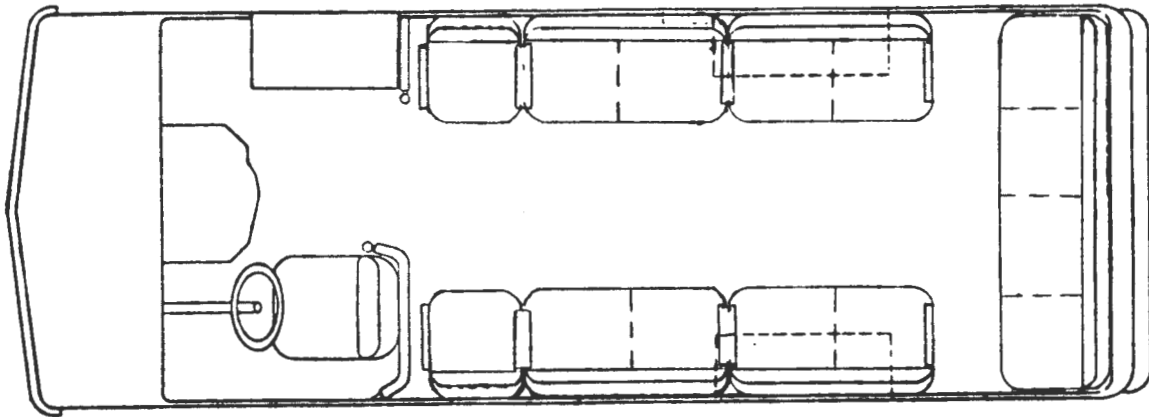

AVAILABLE FLOOR PLANS
(Light Transit Vehicles)

LTV-10-1
(OPTION #1)

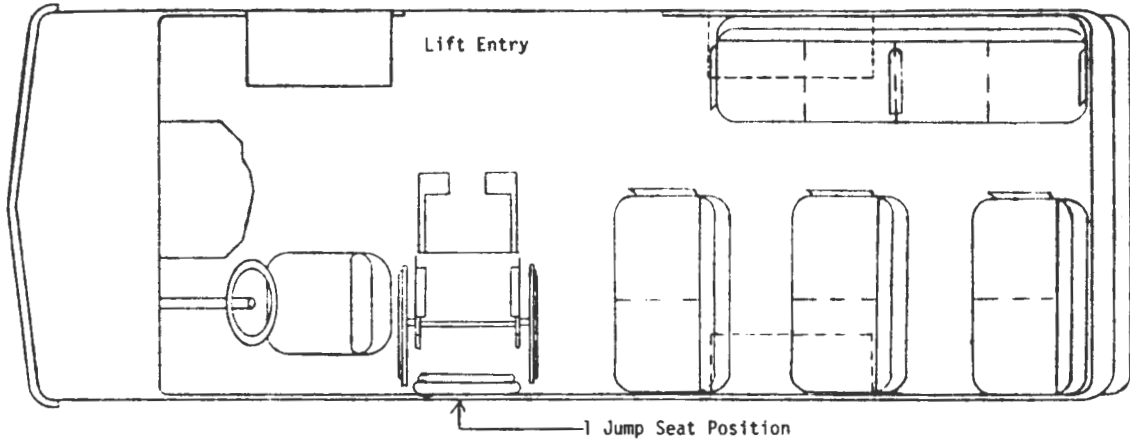

LTV-10-1
(OPTION #2)

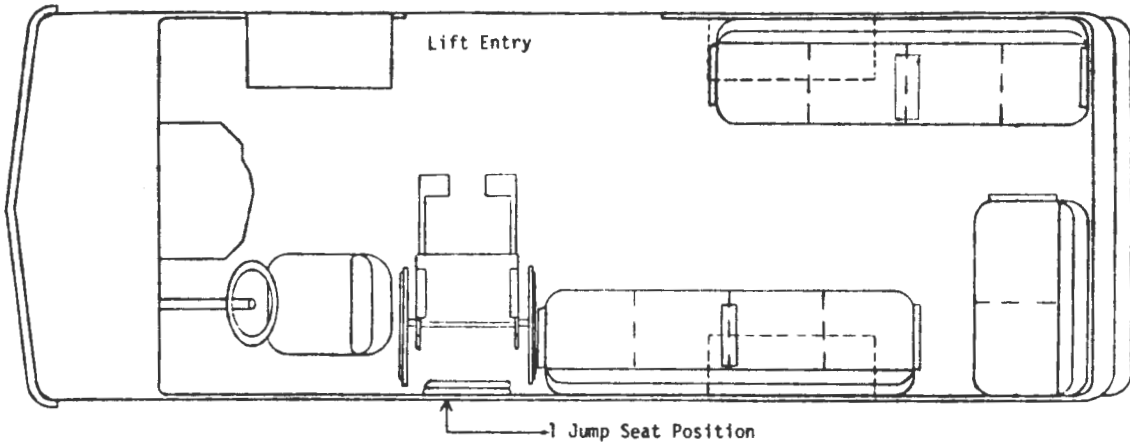

AVAILABLE FLOOR PLANS
(Light Transit Vehicles)

LTV-8-2
(OPTION #1)

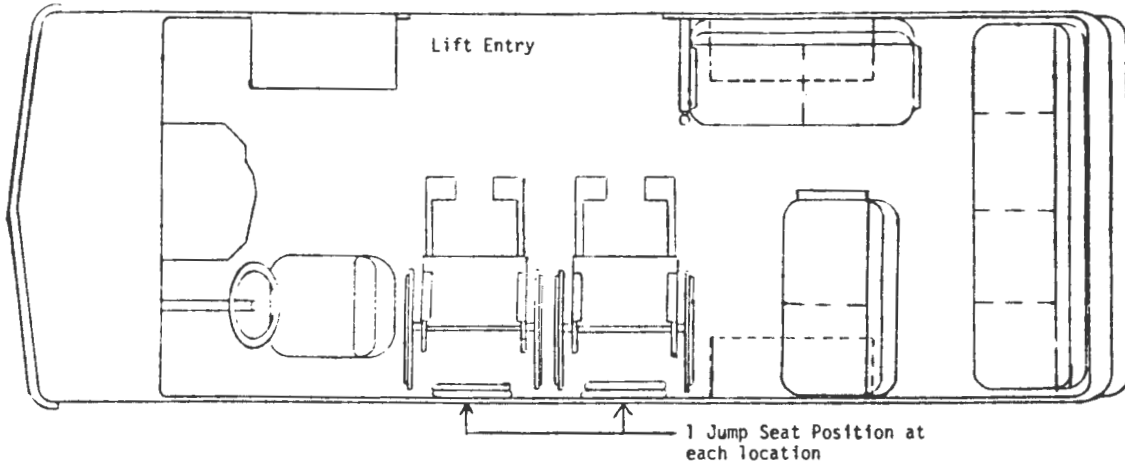

LTV-8-2
(OPTION #2)

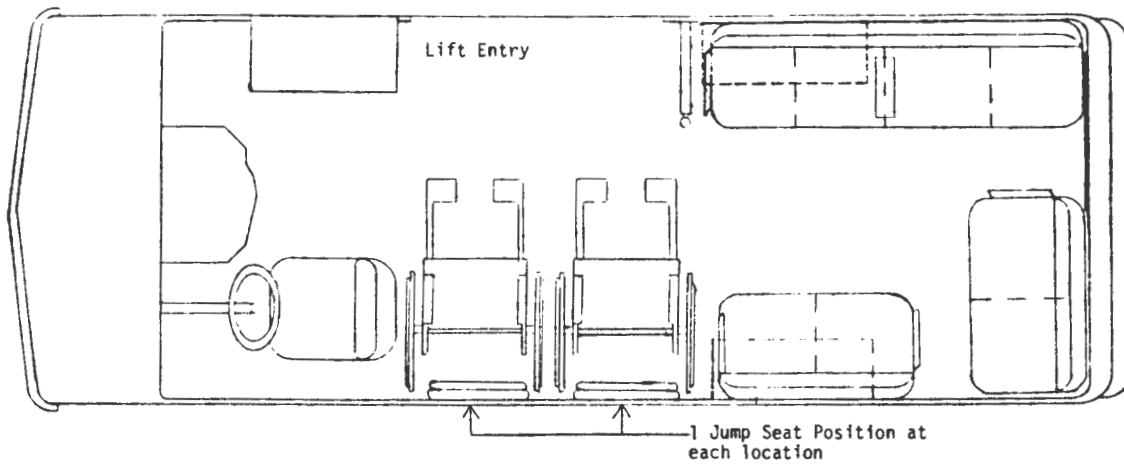

AVAILABLE FLOOR PLANS
(Light Transit Vehicles)

LTV-6-3
(OPTION #1)

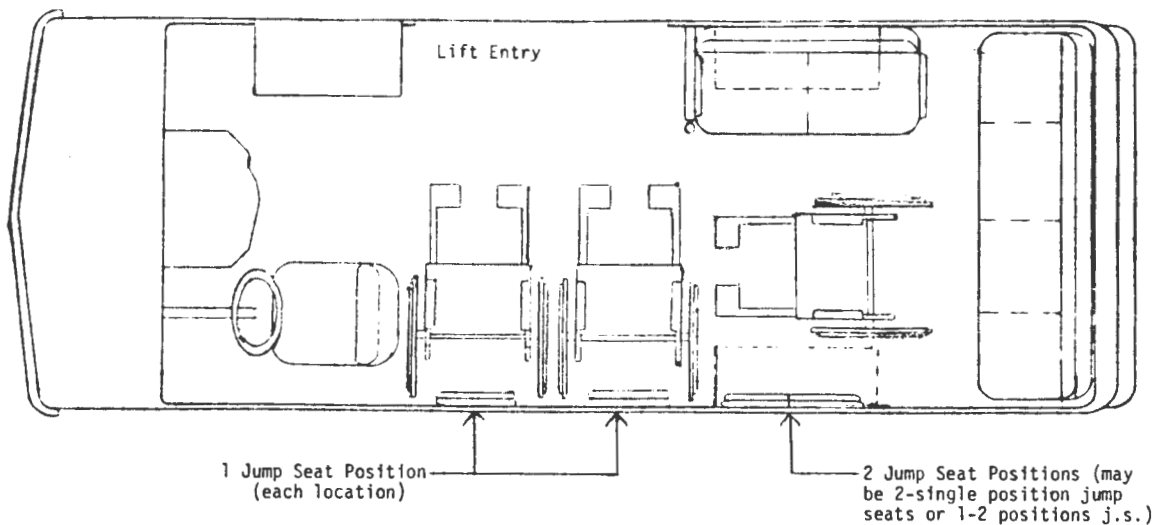

LTV-6-3
(OPTION #2)

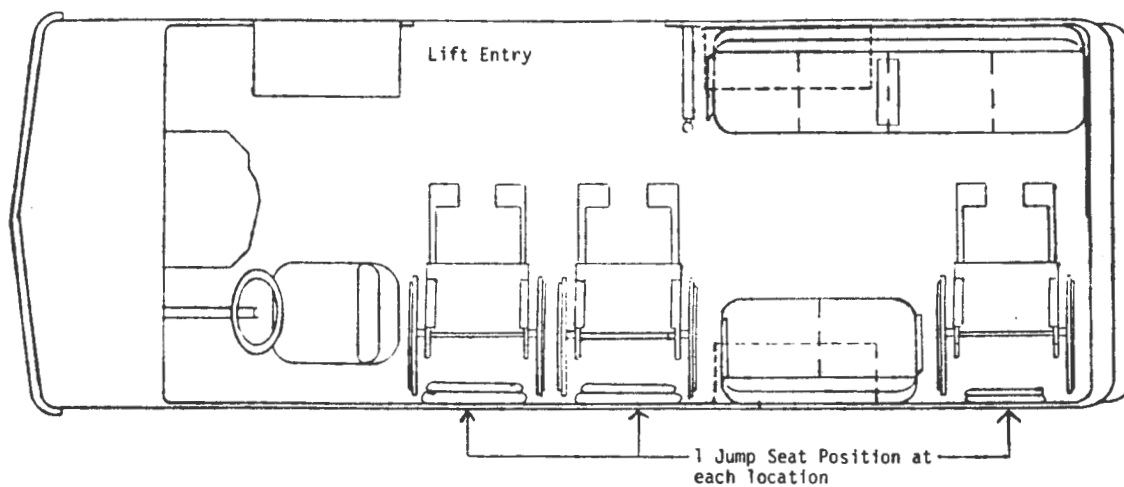

III-C. BUS SERIES

TABLE OF CONTENTS - SECTION III-C

	<u>Page</u>
III. <u>TYPES OF VEHICLES AVAILABLE - C. Bus Series</u>	III-C-ii
1. <u>Modified School Buses (Category A Buses)</u>	III-C-1
a. Illustration 28 - Carpenter Cadet "CV"	III-C-5
b. Illustration 29 - Carpenter Cadet "CV" with Wheelchair Lift	III-C-6
c. Illustration 30 - Blue Bird Mini-Bird	III-C-7
d. Illustration 31 - Blue Bird Mini-Bird with Wheelchair Lift	III-C-8
e. Illustration 32 - Wayne Lifeguard	III-C-9
f. Illustration 33 - Wayne Lifeguard with Wheelchair Lift	III-C-10
g. Illustration 34 - Thomas Body on GMC Chassis	III-C-11
h. Available Floor Plans for Modified School Buses	III-C-12
2. <u>Light Buses (Category B Buses)</u>	III-C-19
a. Illustration 35 - Carpenter Cadet with Wheelchair Lift	III-C-23
b. Illustration 36 - Wide Body Carpenter Cadet	III-C-24
c. Illustration 37 - Thomas Mighty Mite F.C. Tour Bus	III-C-25
d. Illustration 38 - Ward Caravans	III-C-26
e. Illustration 39 - Ward Amtran	III-C-27
f. Available Floor Plans for Light Buses	III-C-28
3. <u>Light Transit Buses (Category C Buses)</u>	III-C-35
a. Illustration 40 - Blue Bird Microbird	III-C-39
b. Illustration 41 - Thomas Minotour	III-C-40
c. Illustration 42 - Thomas Minotour with Wheelchair Lift	III-C-41
d. Illustration 43 - Ward Vanguard	III-C-42
e. Illustration 44 - Wayne Chaperone	III-C-43
f. Available Floor Plans for Light Transit Buses	III-C-44

BUS SERIES

This series of small to medium size buses, intended for transit purposes, will provide vehicles involving the construction of a bus body on a light or medium duty truck chassis or on a commercial van cutaway chassis. The bus manufacturer purchases a "Detroit type" truck or cutaway van chassis and builds a body on to it. The body will be constructed of metal body panels attached to a structural steel frame.

A wide range of seating capacities is offered in the bus series; varying from as few as 17 passengers to as many as 31 passengers. All may be equipped with wheelchair lifts, if desired, and may accommodate as many as 8 wheelchairs at one time (regular passenger seating is then reduced to 7). Of course, the seating capacity for a given size of bus is reduced when a wheelchair lift and wheelchair position(s) are included.

Buses provide a more spacious interior for a specified number of passenger seats and/or wheelchair positions than do converted vans or light transit vehicles. The minimum aisle width permitted is 16" (vs. 12" for Van "C" and 13" for LTV). Also, each seating position for buses must be at least 18" per passenger vs. 17" for LTVs. One drawback of buses is that they are more bulky vehicles per number of passengers transported as compared to vans or LTVs.

Three categories of vehicles are offered in the bus series, as follows:

1. Modified School Bus (Bus, Category "A")
2. Light Bus (Bus, Category "B")
3. Light Transit Bus (Bus, Category "C")

The above categories of buses are discussed on the following pages.

III-C. BUS SERIES

**1. MODIFIED SCHOOL BUS
(CATEGORY A BUS)**

Modified School Bus (Bus, Category "A")

A Modified School Bus is a basic school bus modified as little as possible to accommodate adult passengers and to comply with State laws. The bus will have no flashing lights or mountings for flashing lights on the exterior of the vehicle above the window level, and will have no other markings identifiable with school buses. The vehicle in no way is to be used, or equipped as, a school bus once acquired. It will, however, conform to the Ohio School Bus Minimum Construction Standards (OSBMCS) with some exceptions which are detailed in ODOT's procurement specifications.

The headroom (inside body height) shall be a minimum of 72" (standard for school buses). Windows will be of the school bus type, i.e., vertical sash. A heavy duty electrical system (battery and alternator) will be required if an air conditioning system and/or a lift is installed in the vehicle. An emergency rear exit door will be provided as standard equipment.

Some standard features of the modified school bus are:

- Manual transmission
- Power brakes
- Power steering
- Jack and lug wrench
- Spare wheel and tire (not mounted on vehicle)
- Undercoating
- Steel body construction (in accordance with school bus standards)
- Choice of manufacturer's standard colors

A modified school bus will provide basic transportation for elderly and/or handicapped passengers. There is nothing "fancy" about this vehicle. The ride will be somewhat "hard" and may be uncomfortable for the type of passengers for which this program is intended. However, this category offers the most economical vehicle, in terms of cost versus capacity, available in this program.

The bus may be equipped with a wheelchair lift and up to eight wheelchair positions. A wheelchair securement system is provided at each wheelchair position. The lift will be installed on the right (curb) side of the vehicle, forward of the rear wheels. A "rear of the vehicle" location of the wheelchair lift is not available in this series and should not be requested, even if the agency believes it has sufficient justification for a rear-mounted lift. A rear-mounted lift, if properly justified, may be requested on a Van "C" vehicle.

On those vehicles with a wheelchair lift, a jump seat option may be selected. The jump seat option will provide fold-down seats at the wheelchair positions (WCPs) for use when the WCPs are not occupied by a wheelchair. The use of the jump seats will increase the seating capacity of the vehicle when the WCPs are not in use. The number of jump seat positions to be provided with each floor plan option is shown in the "Vehicles Available" table.

Ancillary equipment for these categories of vehicles is listed below. Illustrations showing various types of buses with and without lifts, and example floor plans for this series are shown on the following pages. Descriptive material for ancillary equipment is shown in Section IV. Cost Estimates are given in Section V, a separately published supplement.

Vehicle Category: Modified School Bus (Bus "A")

Vehicles Available:

<u>Vehicle Designation</u>	<u>Adult Seating</u> (1)	<u>Lift Provided?</u>	<u>Number of WCPs</u> (2)	<u>Number of JSPs</u> (3)
BA-17-0*	17	No	0	0
BA-21-0*	21	No	0	0
BA-25-0	25	No	0	0
BA-31-0	31	No	0	0
BA-11-2	11	Yes	2	2
BA-15-2	15	Yes	2	2
BA-19-2	19	Yes	2	2
BA-11-4	11	Yes	4	4
BA-15-4	15	Yes	4	4
BA-11-6	11	Yes	6	6
BA- 7-8	7	Yes	8	8

Notes: *Two floor plan layouts are possible for this designation (and two example floor plans are shown) since a vehicle with a minimum width of 79" or one of 88" may be bid.

- (1) Regular Adult Seating Capacity (the driver is not included in this total nor are the jump seat positions).
- (2) WCPs = Wheelchair Positions provided on vehicle.
- (3) JSPs = Jump Seat Positions. This column indicates the number of jump seat positions that will be provided for this vehicle if the Jump Seat Option is chosen. Jump seat locations are shown on the floor plan drawings.

Colors Available:

The colors listed below are generic colors available in the Bus series. Please indicate on the application the color desired for your vehicle. The purchase order, written after the make of the vehicle is determined via the bidding process, will specify the brand-name color most closely matching the generic color chosen.

- | | |
|----------------------|---------------|
| 1. White | 6. Dark Brown |
| 2. Black | 7. Light Blue |
| 3. Red | 8. Dark Blue |
| 4. Beige (Off-White) | 9. Dark Green |
| 5. Tan (Light Brown) | 10. Silver |

Floor Plans Available:

Drawings of example floor plan layouts for this category of buses are shown following the text of this section. These floor plans are intended as guides to the manufacturer. In most cases, the supplied vehicle will furnish a floor plan similar to the example. However, there may be some variances, according to the manufacturer, because of the locations of the wheelwell covers in relation to the rear of the bus.

Ancillary Equipment (Provided):

The following equipment will be provided on each vehicle and no additional action is required by the agency.

1. Locking Front Passenger Entrance Door
2. Locking Hand Throttle
3. Power Steering and Power Brakes
4. Heavy-duty double acting shock absorbers
5. Large Battery and Alternator
 - a. Buses without air conditioner or wheelchair lift will provide, as minimums, an 80 amp-hour battery and a 90 amp alternator
 - b. Buses with air conditioner and/or wheelchair lift will provide, as minimums, a 150 amp-hour battery and a 130 amp alternator
6. Large Fuel Tank (total capacity of at least 30 U.S. gallons)
7. Emergency Equipment
8. Undercoating
9. Seat Belts (driver and all passengers)
10. Left and Right Hand Outside Mirrors with Spot Mirrors

Ancillary Equipment (Optional):

The following equipment is available for each vehicle as an option. The agency must specify in its application what options are desired. These options will cost extra; and estimated prices are given in Section V.

1. Wheelchair Lift (includes wheelchair securement system and wheelchair occupant restraint system)
2. Jump Seat (fold-down seats at a wheelchair position to provide regular seating when wheelchairs are not present)
3. Air Conditioning (front and rear)
4. Radial Tires
5. Two-way FM Radio (VHF-low, VHF-high or UHF band) Mobile Units
6. Driver Hand Controls (for operation of the vehicle)
7. Wheelchair Accessibility Symbol (on outside of vehicle)

Unavailable Ancillary Equipment:

The following equipment is not available through this program and should not be requested.

1. Wheelchair ramp (instead of a wheelchair lift)
2. Overhead flashing lights
3. Running boards
4. Luggage Rack
5. Logos painted on the side of the vehicle
6. CB radio, commercial band radio, or tape player
7. Special or fancy wheelcovers
8. Special paint job



ILLUSTRATION 28 - MODIFIED SCHOOL BUS (CATEGORY A BUS)

- CARPENTER CADET 'CV'

Source: Carpenter Body Works, Inc.

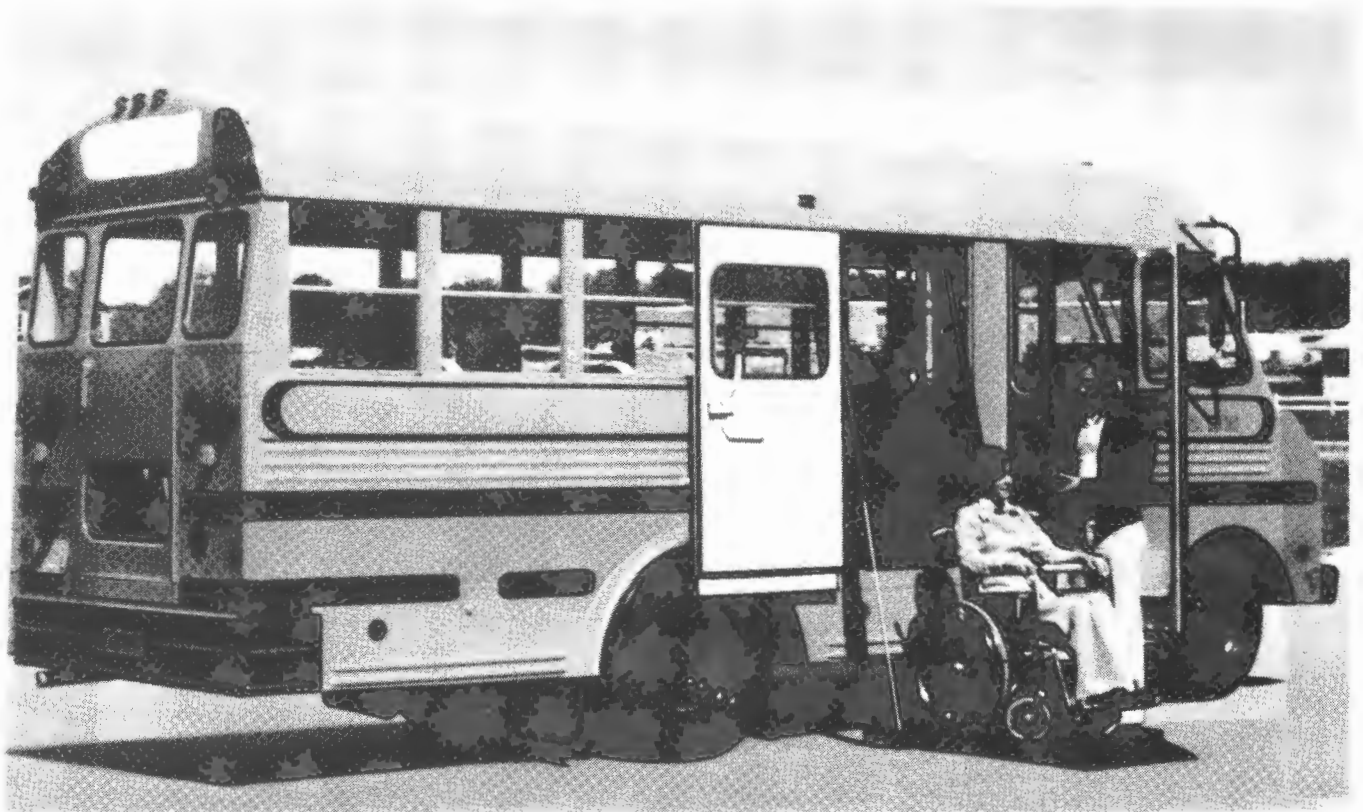

ILLUSTRATION 29 - MODIFIED SCHOOL BUS (CATEGORY A BUS)

- CARPENTER CADET 'CV' WITH WHEELCHAIR LIFT

Source: Carpenter Body Works, Inc.



ILLUSTRATION 30 - MODIFIED SCHOOL BUS (CATEGORY A BUS)

- BLUE BIRD MINI-BIRD

Source: Blue Bird Coach

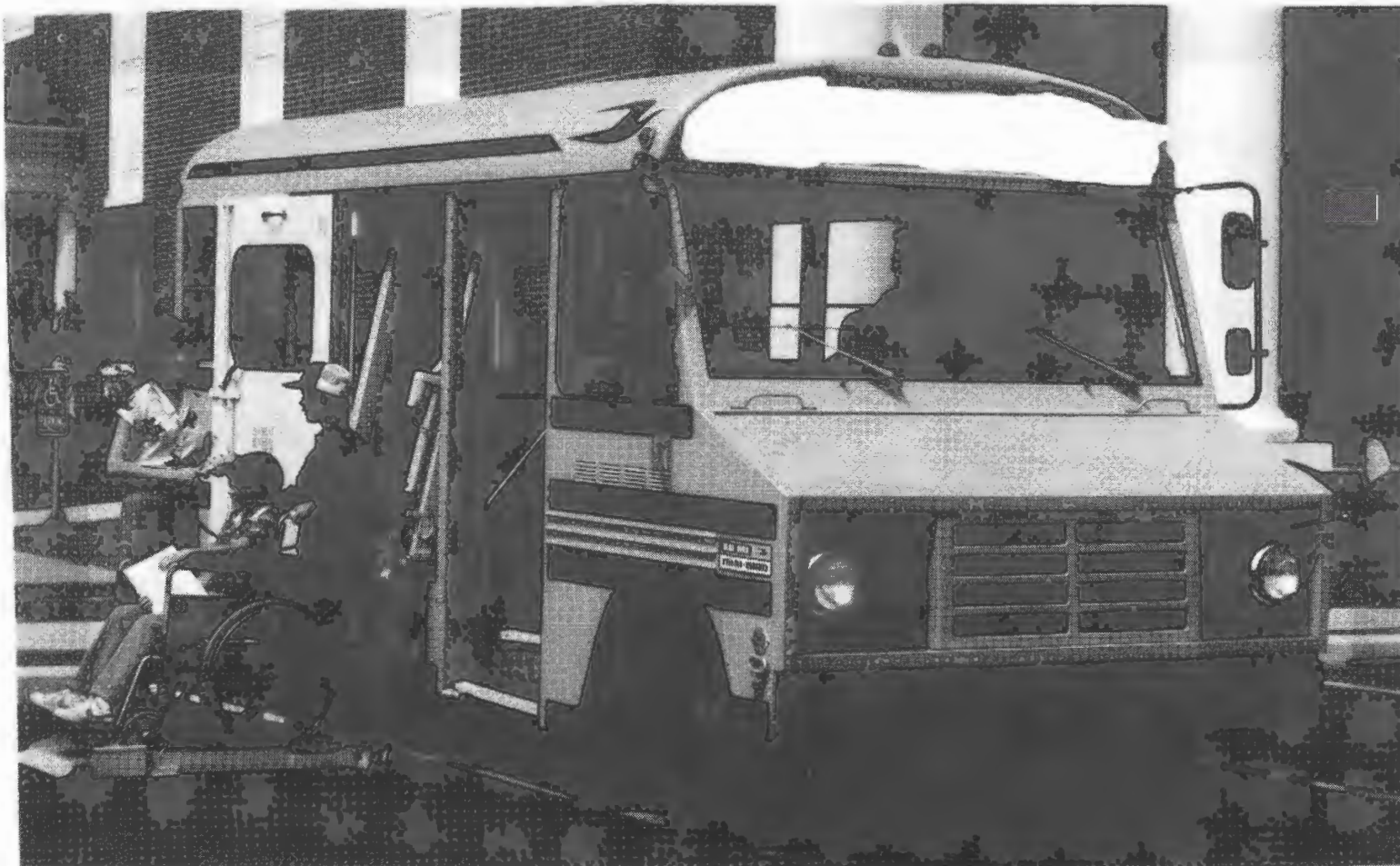

ILLUSTRATION 31 - MODIFIED SCHOOL BUS (CATEGORY A BUS)

- BLUE BIRD MINI-BIRD WITH WHEELCHAIR LIFT

Source: Blue Bird Coach

III-C-9

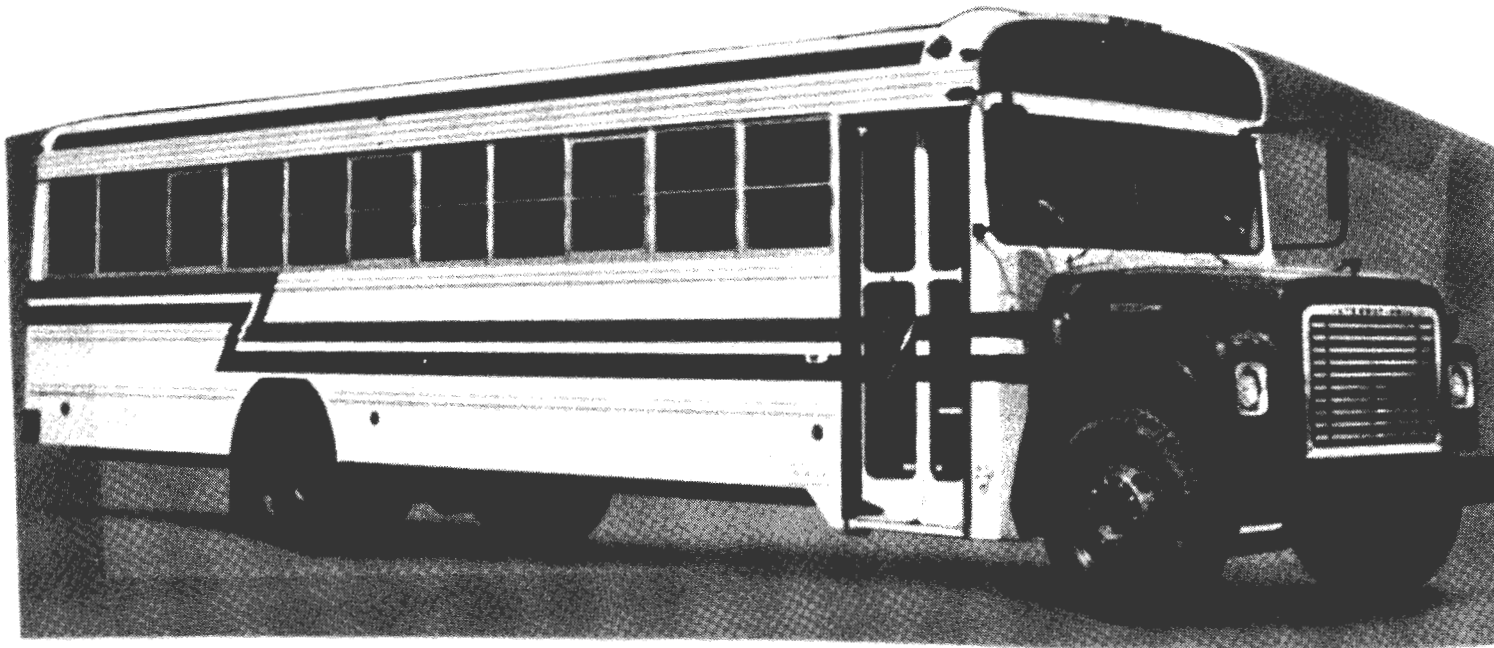

ILLUSTRATION 32 - MODIFIED SCHOOL BUS (CATEGORY A BUS)

- WAYNE LIFEGUARD

Source: Wayne Corporation

III-C-19



ILLUSTRATION 33 - MODIFIED SCHOOL BUS (CATEGORY A BUS)

- WAYNE LIFEGUARD WITH WHEELCHAIR LIFT

Source: Wayne Corporation

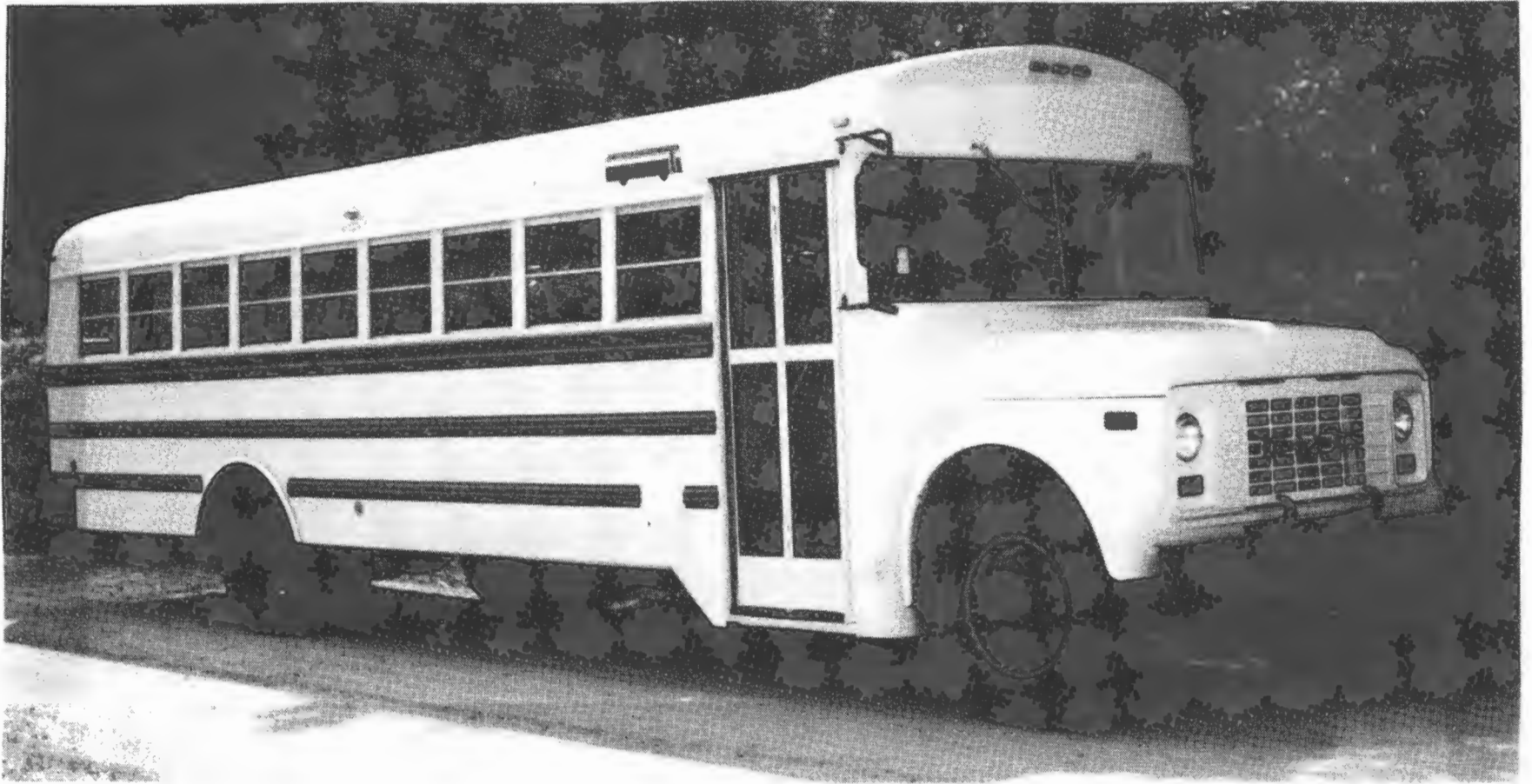

ILLUSTRATION 34 - MODIFIED SCHOOL BUS (CATEGORY A BUS)

- THOMAS BODY ON GMC CHASSIS

Source: Thomas Built Buses, Inc.

AVAILABLE FLOOR PLANS
(Modified School Buses)

BA-17-0 (#1)

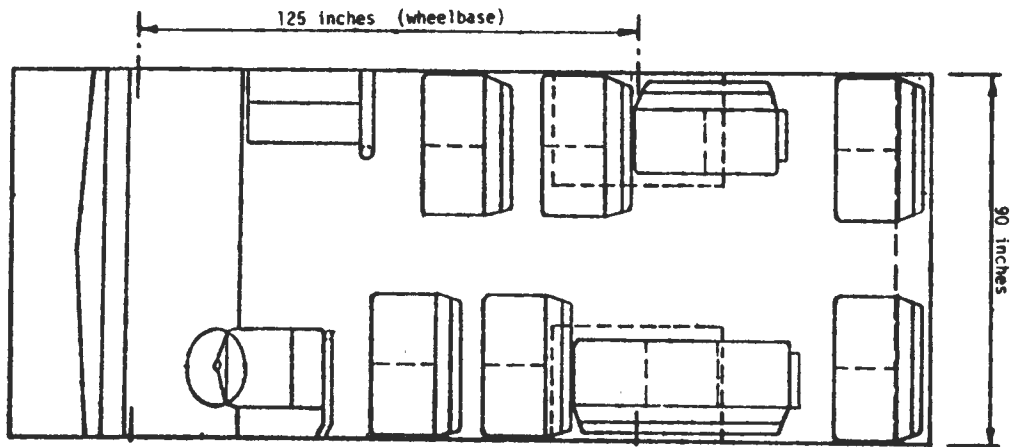

Note: This example provides 17 regular passenger seating positions.

BA-17-0 (#2)

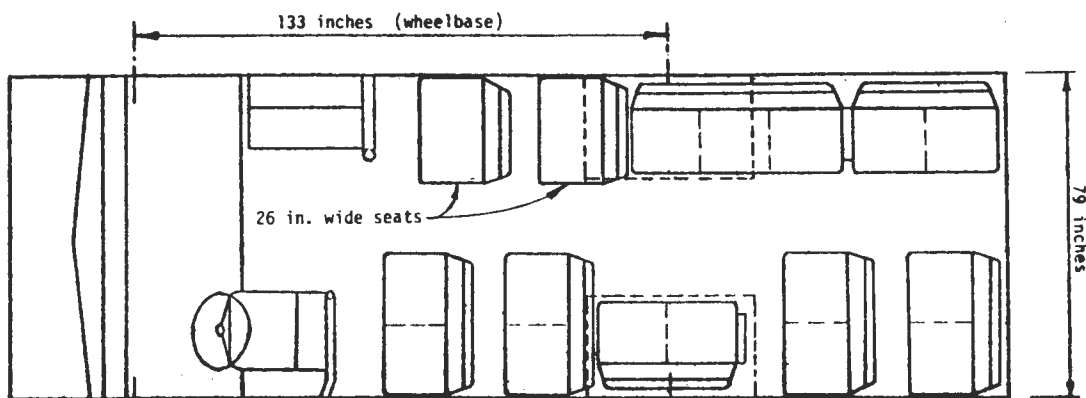

Note: This example provides 17 regular passenger seating positions.

AVAILABLE FLOOR PLANS
(Modified School Buses)

BA-21-0 (#1)

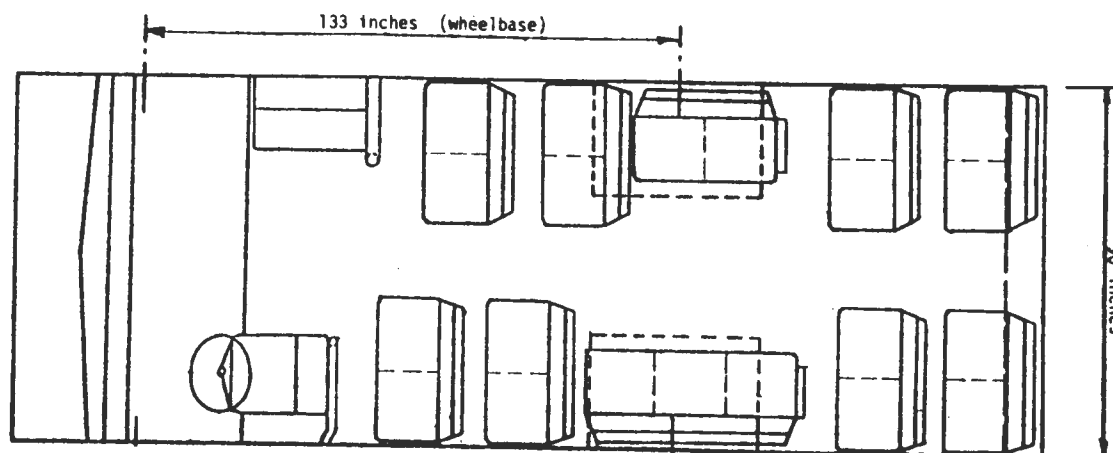

Note: This example provides 21 regular passenger seating positions.

BA-21-0 (#2)

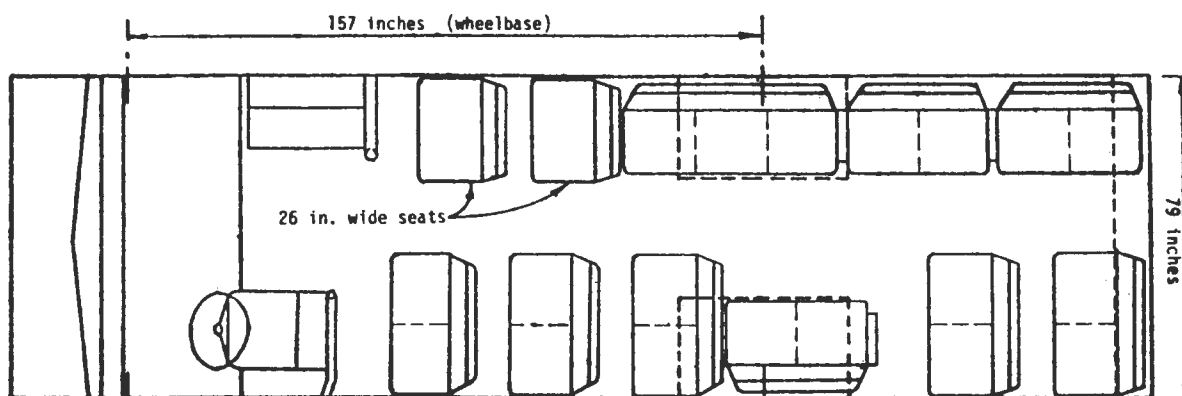

Note: This example provides 21 regular passenger seating positions.

AVAILABLE FLOOR PLANS
(Modified School Buses)

BA-25-0

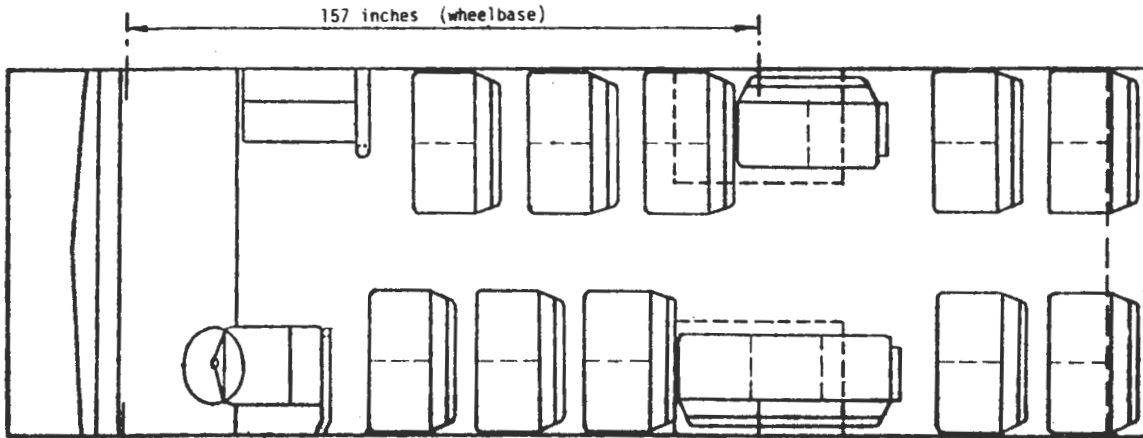

Note: This example provides 25 regular passenger seating positions.

BA-31-0

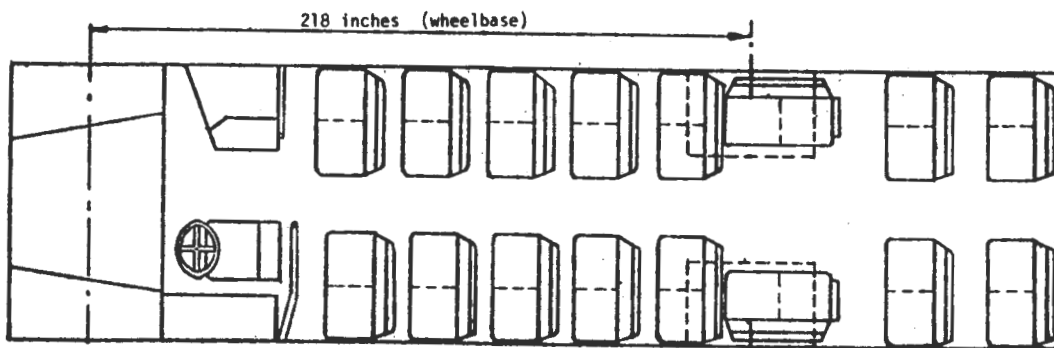

Note: This example provides 32 regular passenger seating positions.

AVAILABLE FLOOR PLANS
(Modified School Buses)

BA-11-2

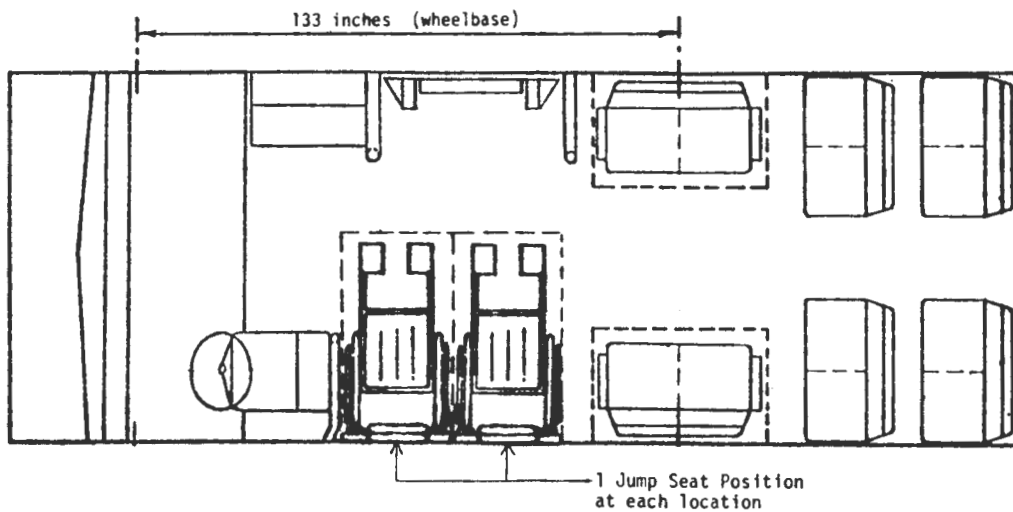

Note: This example provides 12 regular passenger seating positions and 2 wheelchair positions.

BA-15-2

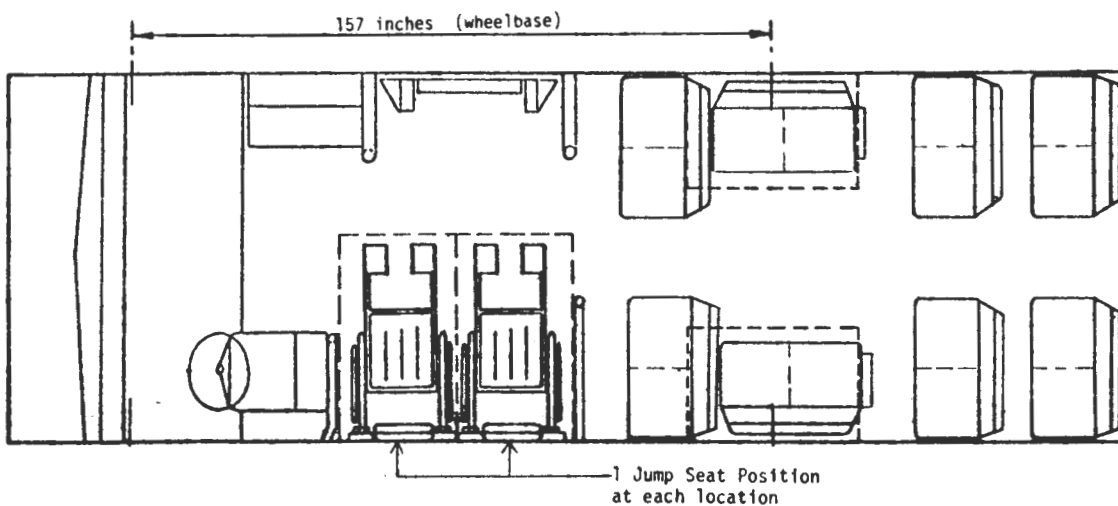

Note: This example provides 16 regular passenger seating positions and 2 wheelchair positions.

AVAILABLE FLOOR PLANS
(Modified School Buses)

BA-19-2

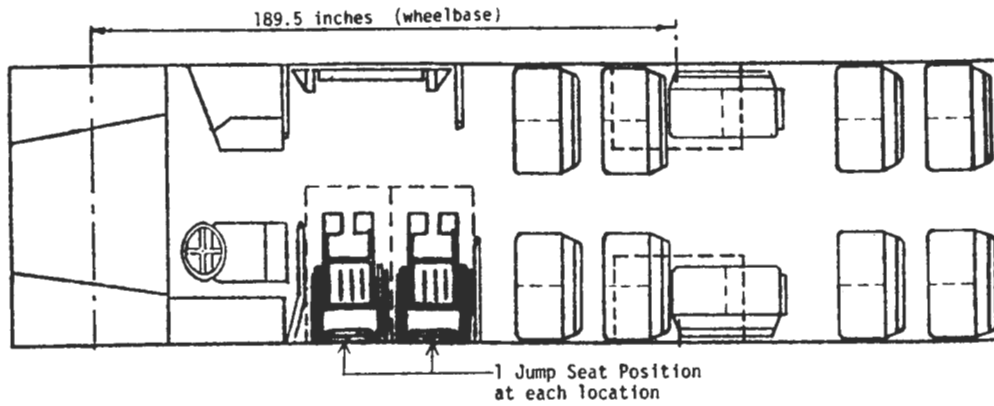

Note: This example provides 20 regular passenger seating positions and 2 wheelchair positions.

BA-11-4

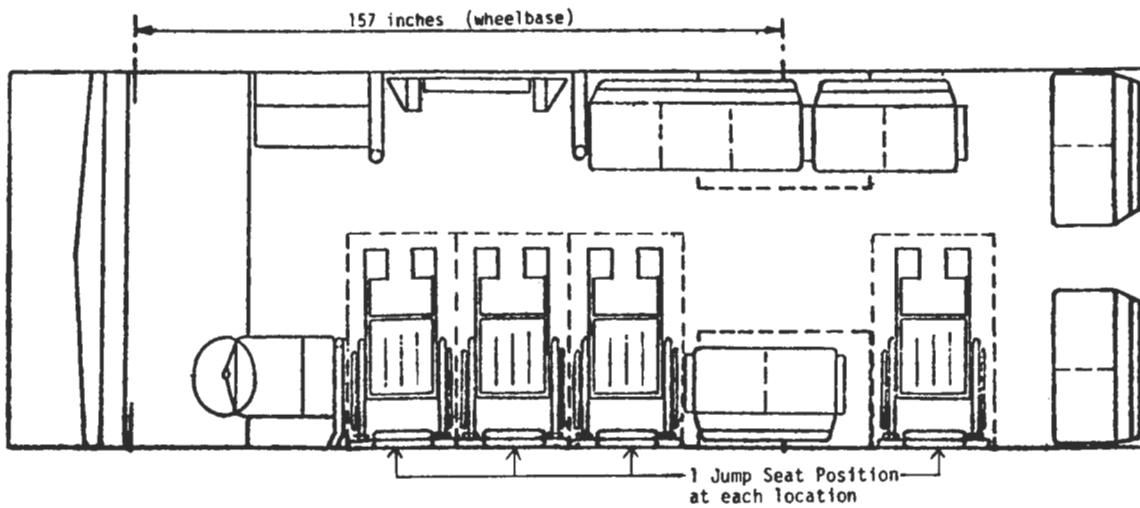

Note: This example provides 11 regular passenger seating positions and 4 wheelchair positions.

AVAILABLE FLOOR PLANS
(Modified School Buses)

BA-15-4

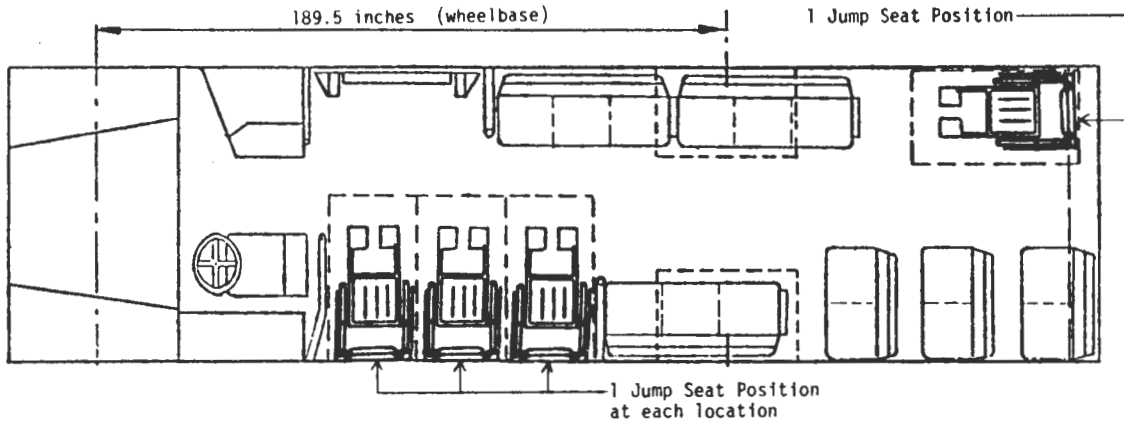

Note: This example provides 15 regular passenger seating positions and 4 wheelchair positions.

BA-11-6

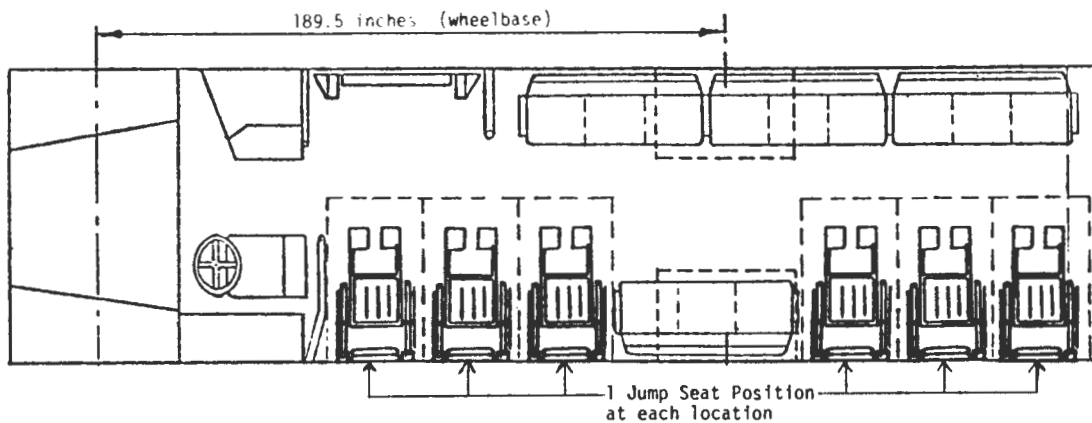

Note: This example provides 12 regular passenger seating positions and 6 wheelchair positions.

AVAILABLE FLOOR PLANS
(Modified School Buses)

BA-7-8

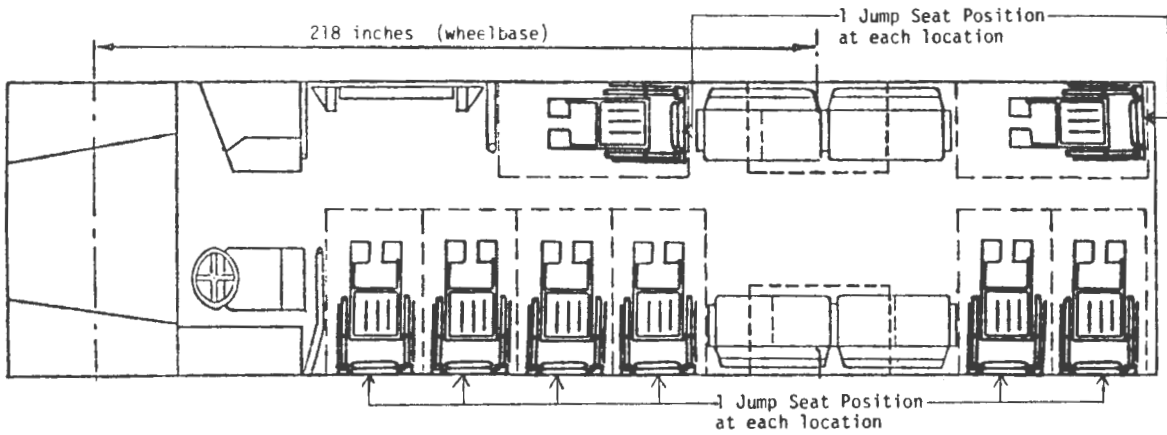

Note: This example provides 8 regular passengers seating positions and 8 wheelchair positions.

III-C. BUS SERIES
2. LIGHT BUS
(CATEGORY B BUS)

Light Bus (Bus, Category "B")

The light bus will be a small (17 passenger) to medium (31 passengers) sized vehicle on a light to medium duty truck chassis. The bus will be of the type normally suited for social service agency transportation. The vehicle body will be a body manufactured by a body manufacturer for bus application, not "converted" to a bus from a sports van, delivery vehicle or recreational vehicle.

The bus will be equipped with adult-sized seating and shall provide adequate room for maneuvering of wheelchairs (if wheelchair transportation is chosen as an option) and ambulatory passengers at the same time. The headroom (inside body height) shall be a minimum of 74.5", the highest ceiling offered in this program. The minimum interior width for the majority (all but the sizes) of the vehicles in this category shall be 88".

The side passenger windows shall be of the horizontal sliding type, giving the vehicle a more pleasing appearance when viewed from the outside. There will be no emergency rear door exit provided; instead, a rear emergency exit window will be furnished (creating a "Hollywood" rear end). However, all federal safety exit requirements will be satisfied by requiring an adequate number of the side windows to be of the emergency exit type.

Some standard features of the light bus include:

- Automatic transmission
- Power brakes
- Power steering
- Low first step height
- Jack and lug wrench
- Spare wheel and tire (not mounted on vehicle)
- Undercoating
- Emergency rear exit window
- Rubber floor covering
- Transit-type passenger windows
- Seat belts (may not be provided with the optional custom seats)
- Stanchions and grab rails
- On those types of vehicles with wheelchair lifts, included would be wheelchair locks and wheelchair occupant restraint systems
- Choice of manufacturer's standard colors

In the past, the successful bidders for light transit buses have been school bus vendors offering small or medium size school buses modified as necessary to meet the ODOT procurement specifications. The modification necessary for this category is much more extensive than required for Bus "A". However, all of the items described under the Bus "A" discussion (such as removal of flashing lights and all school bus markings) are performed as well as several additional items. The light bus will provide more than basic transportation for elderly and/or handicapped passengers. The exterior appearance of the vehicle will be more pleasing than the

modified school bus. Custom seats are available as an option. Driving of the bus will be easier since it will be equipped with an automatic transmission. The "ride" will be about the same as the modified school bus. However, the "ride" may be somewhat softened by the inclusion of the radial tires option.

The bus may be equipped with a wheelchair lift and up to eight wheelchair positions. A wheelchair securement system is provided at each wheelchair position. The lift will be installed on the right (curb) side of the vehicle, forward of the rear wheels. A "rear of the vehicle" location of the wheelchair lift is not available in this series and should not be requested, even if the agency believes it has sufficient justification for a rear-mounted lift. A rear-mounted lift, if properly justified, may be requested on a Van "C" vehicle.

On those vehicles with a wheelchair lift, a jump seat option may be selected. The jump seat option will provide fold-down seats at the wheelchair positions (WCPs) for use when the WCPs are not occupied by a wheelchair. The use of the jump seats will increase the seating capacity of the vehicle when the WCPs are not in use. The number of jump seat positions to be provided with each floor plan option is shown in the "Vehicles Available" table.

Ancillary equipment for this category of vehicles is listed below. Illustrations showing various makes of buses with and without lifts, and example example floor plans for this series are shown on the following pages. Descriptive material for ancillary equipment is shown in Section IV. Cost Estimates are given in Section V, a separately published supplement.

Vehicle Category: Light Bus (Bus "B")

Vehicles Available:

<u>Vehicle Designation</u>	<u>Adult Seating</u> (1)	<u>Lift Provided?</u>	<u>Number of WCPs</u> (2)	<u>Number of JSPs</u> (3)
BB-17-0*	17	No	0	0
BB-21-0*	21	No	0	0
BB-25-0	25	No	0	0
BB-31-0	31	No	0	0
BB-11-2	11	Yes	2	2
BB-15-2	15	Yes	2	2
BB-19-2	19	Yes	2	2
BB-11-4	11	Yes	4	4
BB-15-4	15	Yes	4	4
BB-11-6	11	Yes	6	6
BB- 7-8	7	Yes	8	8

Notes: *Two floor plan layouts are possible for this designation (and two example floor plans are shown) since a vehicle with a minimum width of 79" or one of 88" may be bid.

- (1) Regular Adult Seating Capacity (the driver is not included in this total nor are jump seat positions).
- (2) WCPs = Wheelchair Positions provided on vehicle.
- (3) JSPs = Jump Seat Positions. This column indicates the number of jump seat positions that will be provided for this vehicle if the Jump Seat Option is chosen. Jump seat locations are shown on the floor plan drawings.

Colors Available:

The colors listed below are generic colors available in the Bus series. Please indicate on the application the color desired for your vehicle. The purchase order, written after the make of the vehicle is determined via the bidding process, will specify the brand-name color most closely matching the generic color chosen.

- | | |
|----------------------|---------------|
| 1. White | 6. Dark Brown |
| 2. Black | 7. Light Blue |
| 3. Red | 8. Dark Blue |
| 4. Beige (Off-White) | 9. Dark Green |
| 5. Tan (Light Brown) | 10. Silver |

Floor Plans Available:

Drawings of example floor plan layouts for this category of buses are shown following the text of this section. These floor plans are intended as guides to the manufacturer. In most cases, the supplied vehicle will furnish the floor plan similar to the example. However, there may be some variances, according to the manufacturer, because of the locations of the wheelwell covers in relation to the rear of the bus. Several floor plans may provide one more seat than the minimum specified to make more efficient use of available space.

Ancillary Equipment (Provided):

The following equipment will be provided on each vehicle and no additional action is required by the agency.

1. Locking Front Passenger Entrance Door
2. Locking Hand Throttle
3. Power Steering and Power Brakes
4. Automatic Transmission
5. Heavy-duty suspension system
6. Large Battery and Alternator
 - a. Buses without air conditioner or wheelchair lift will provide, as minimums, an 80 amp-hour battery and a 90 amp alternator
 - b. Buses with air conditioner and/or wheelchair lift will provide, as minimums, a 150 amp-hour battery and a 130 amp alternator
7. Large Fuel Tank (total capacity of at least 30 U.S. gallons)

8. Emergency Equipment
9. Undercoating
10. Seat Belts (driver and all passengers)
11. Rear Auxiliary Heater
12. Tinted Glass in Windshield and all Windows
13. Left and Right Hand Outside Mirrors with Spot Mirrors

Ancillary Equipment (Optional):

The following equipment is available for each vehicle as an option. The agency must specify in its application what options are desired. These options will cost extra; and estimated prices are given in Section V, a separately published supplement.

1. Wheelchair Lift (includes wheelchair securement system and wheelchair occupant restraint system)
2. Jump Seat (fold-down seats at a wheelchair position to provide regular seating when wheelchairs are not present)
3. Custom Seats (deluxe passenger seats)
4. Air Conditioning (front and rear)
5. Radial Tires
6. Two-way FM Radio (VHF-low, VHF-high or UHF band) Mobile Units
7. Driver Hand Controls (for operation of the vehicle)
8. Wheelchair Accessibility Symbol (on outside of vehicle)

Unavailable Ancillary Equipment:

The following equipment is not available through this program and should not be requested.

1. Wheelchair ramp (instead of a wheelchair lift)
2. Rear-mounted wheelchair lift
3. Overhead flashing lights
4. Luggage Rack (interior or exterior)
5. Logos painted on the side of the vehicle
6. CB radio, commercial band radio, or tape player
7. Special or fancy wheelcovers
8. Special paint job



ILLUSTRATION 35 - LIGHT BUS (CATEGORY B BUS)

CARPENTER CADET WITH WHEELCHAIR LIFT

Source: Carpenter Body Works, Inc.



111-C-24

ILLUSTRATION 36 - LIGHT BUS (CATEGORY B BUS)

WIDE BODY CARPENTER CADET

Source: Carpenter Body Works, Inc.



III-C-25

ILLUSTRATION 37 - LIGHT BUS (CATEGORY B BUS)

THOMAS MIGHTY MITE F.C. TOUR BUS

Source: Thomas Built Buses

III-C-26

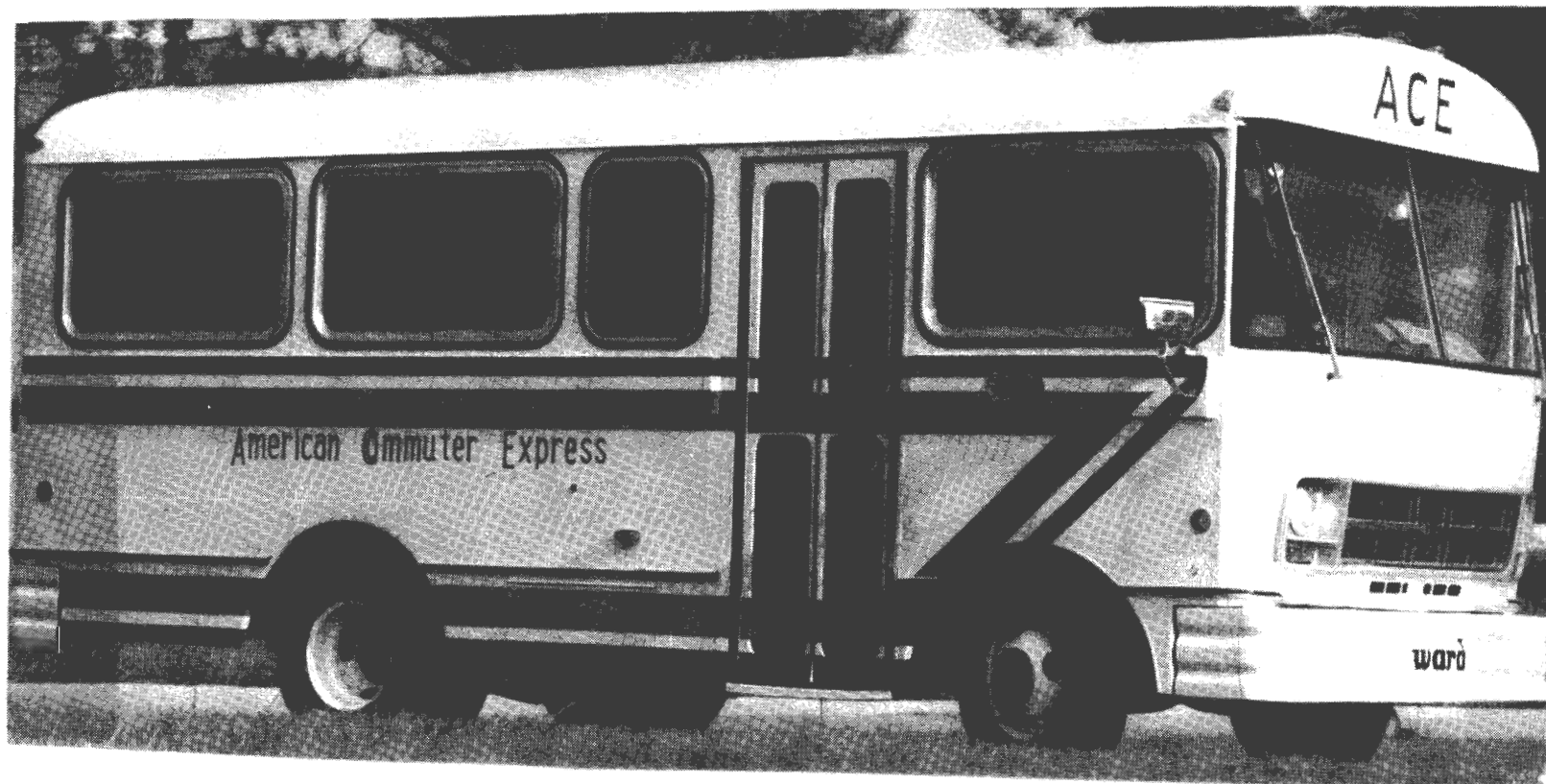

ILLUSTRATION 38 - LIGHT BUS (CATEGORY B BUS)

WARD CARAVANS

Source: Ward Industries

III-C-27



ILLUSTRATION 39 - LIGHT BUS (CATEGORY B BUS)

WARD AMTRAN

Source: Ward Industries

AVAILABLE FLOOR PLANS
(Light Buses)

BB-17-0 (#1)

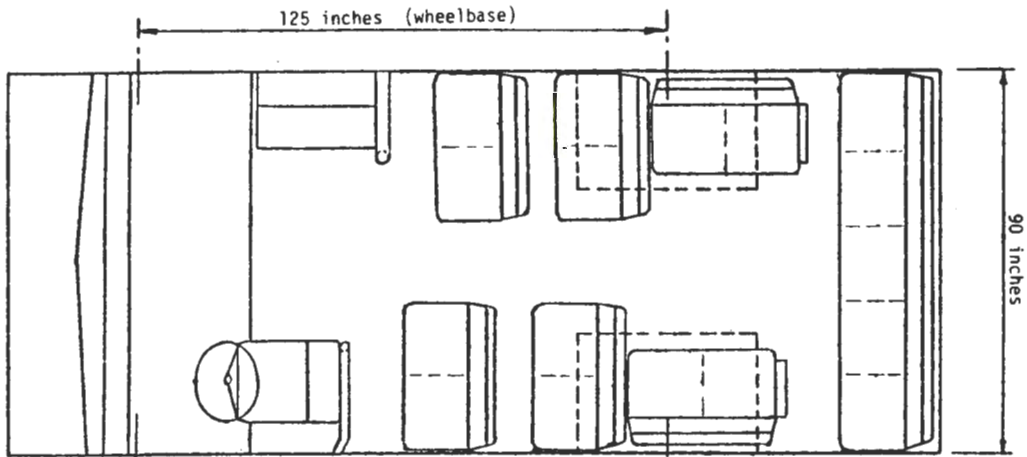

Note: This example provides 17 regular passenger seating positions.

BB-17-0 (#2)

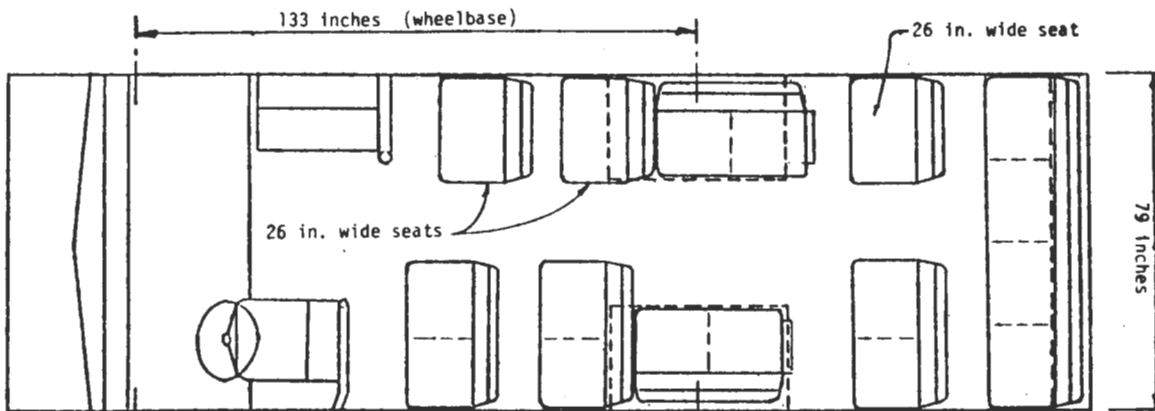

Note: This example provides 17 regular passenger seating positions.

AVAILABLE FLOOR PLANS
(Light Buses)

BB-21-0 (#1)

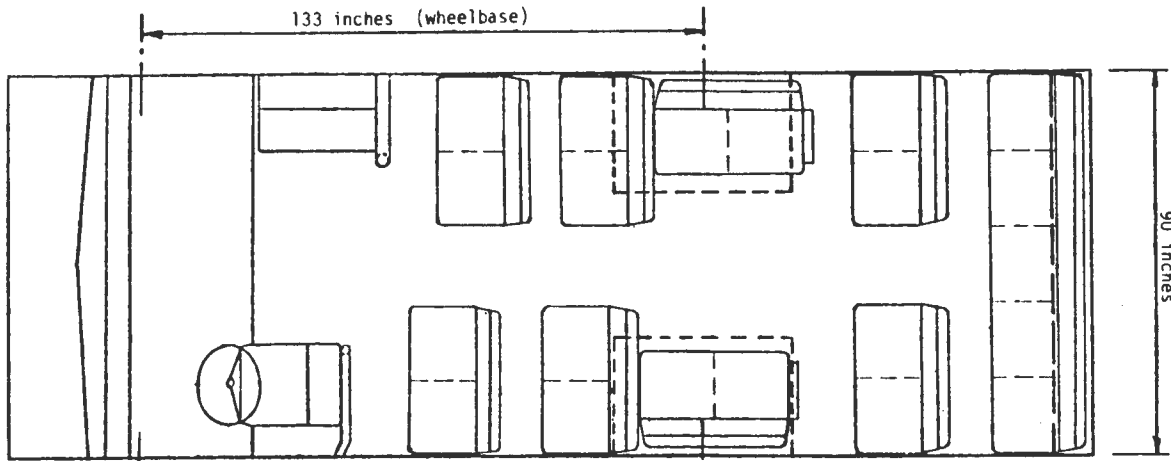

Note: This example provides 21 regular passenger seating positions.

BB-21-0 (#2)

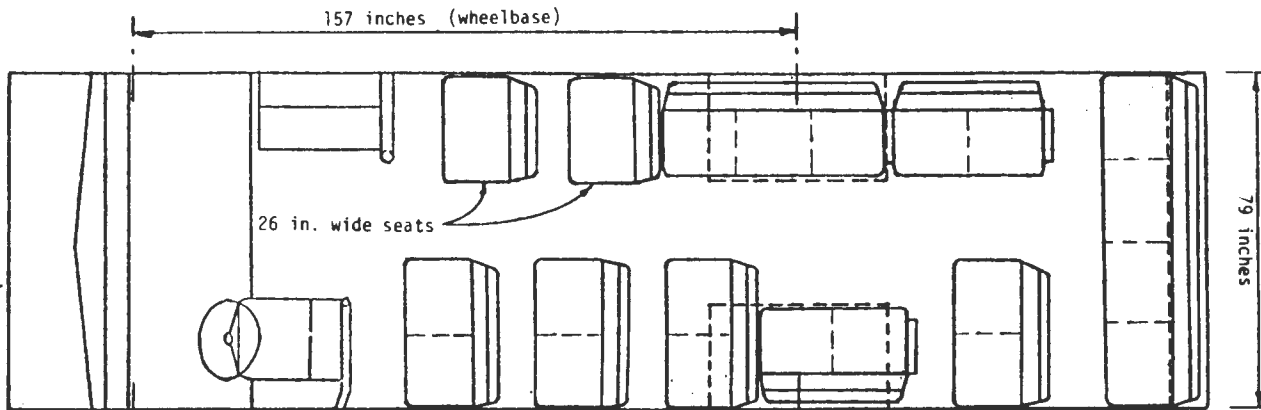

Note: This example provides 21 regular passenger seating positions.

AVAILABLE FLOOR PLANS
(Light Buses)

BB-25-0

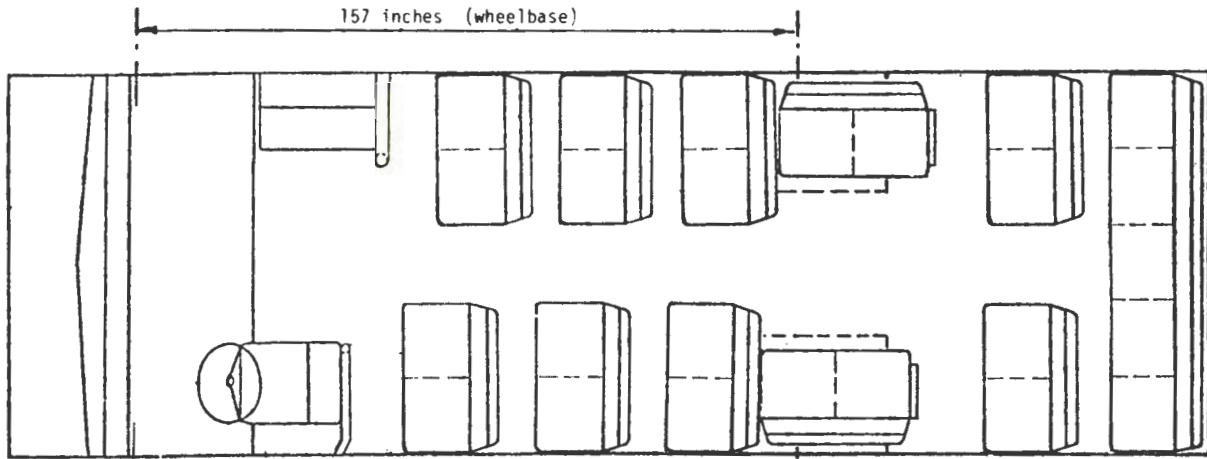

Note: This example provides 25 regular passenger seating positions.

BB-31-0

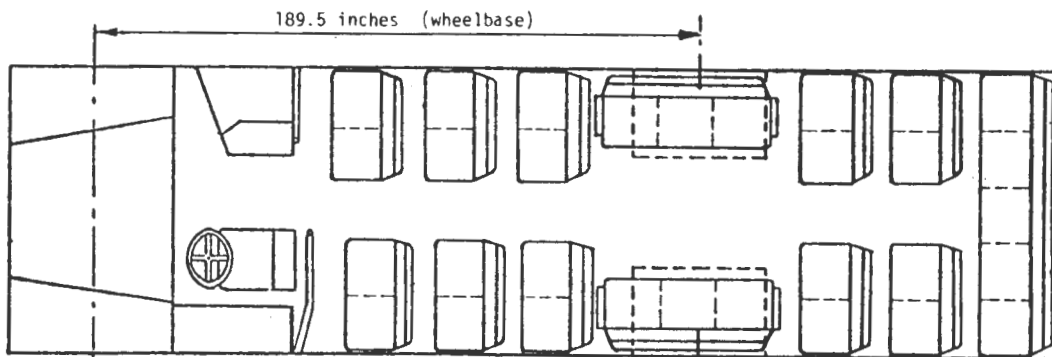

Note: This example provides 31 regular passenger seating positions.

AVAILABLE FLOOR PLANS
(Light Buses)

BB-11-2

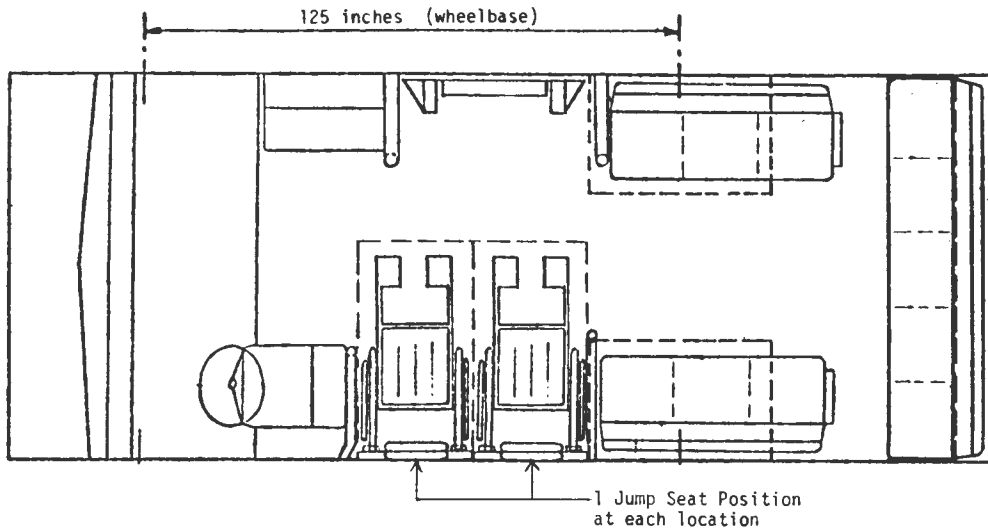

Note: This example provides 11 regular passenger seating positions and 2 wheelchair positions.

BB-15-2

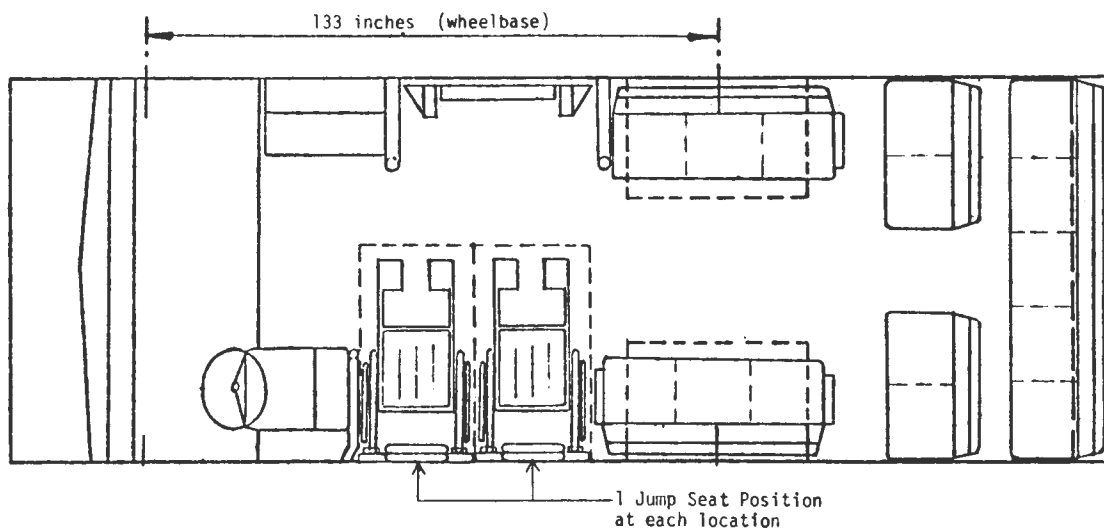

Note: This example provides 15 regular passenger seating positions and 2 wheelchair positions.

AVAILABLE FLOOR PLANS
(Light Buses)

BB-19-2

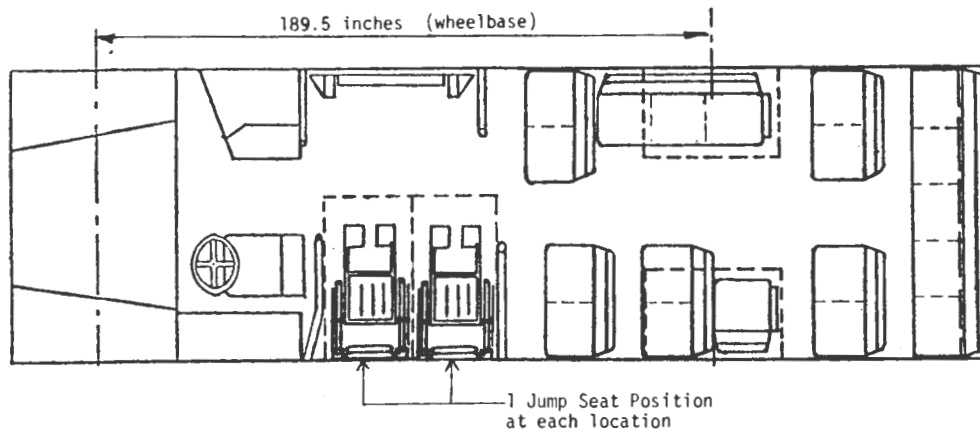

Note: This example provides 19 regular passenger seating positions and 2 wheelchair positions.

BB-11-4

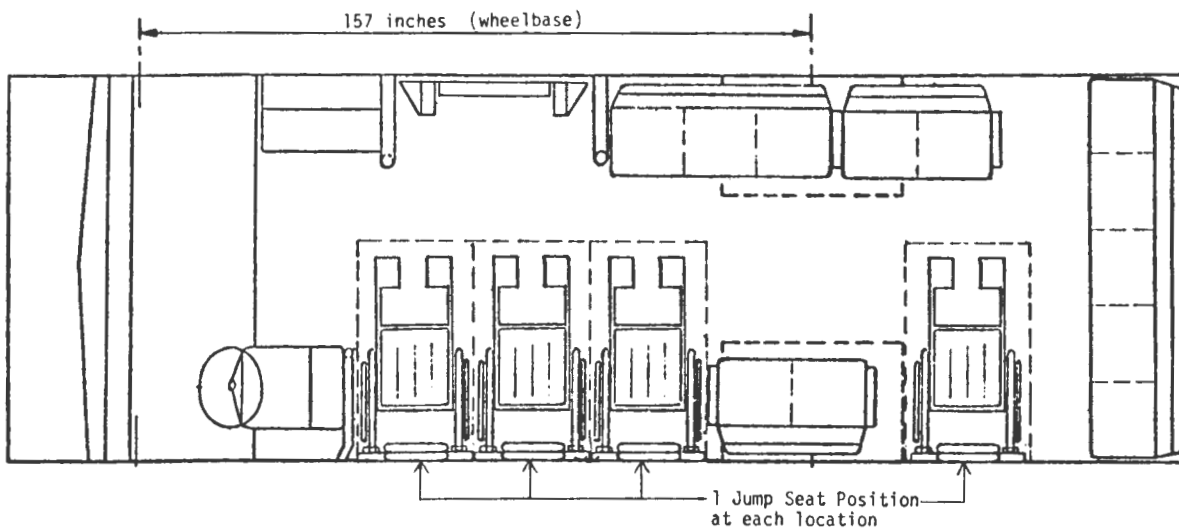

Note: This example provides 12 regular passenger seating positions and 4 wheelchair positions.

AVAILABLE FLOOR PLANS
(Light Buses)

BB-15-4

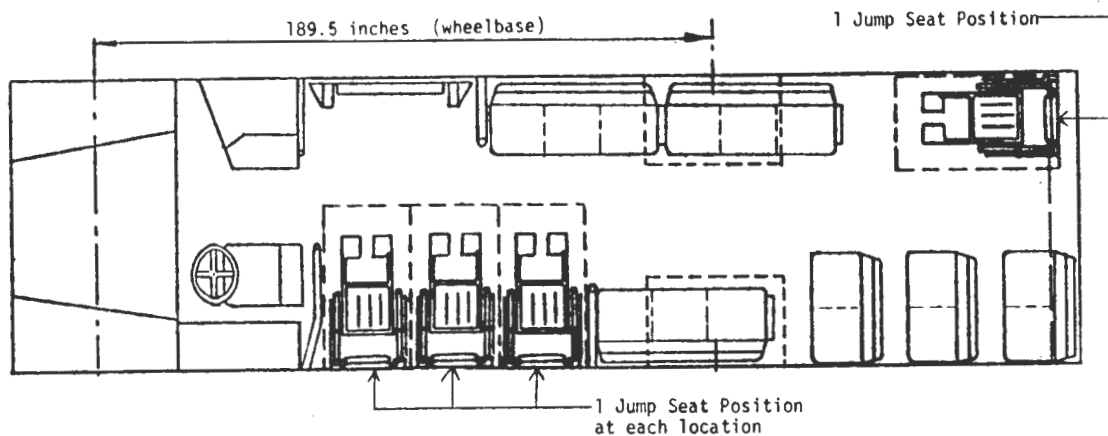

Note: This example provides 15 regular passenger seating positions and 4 wheelchair positions.

BB-11-6

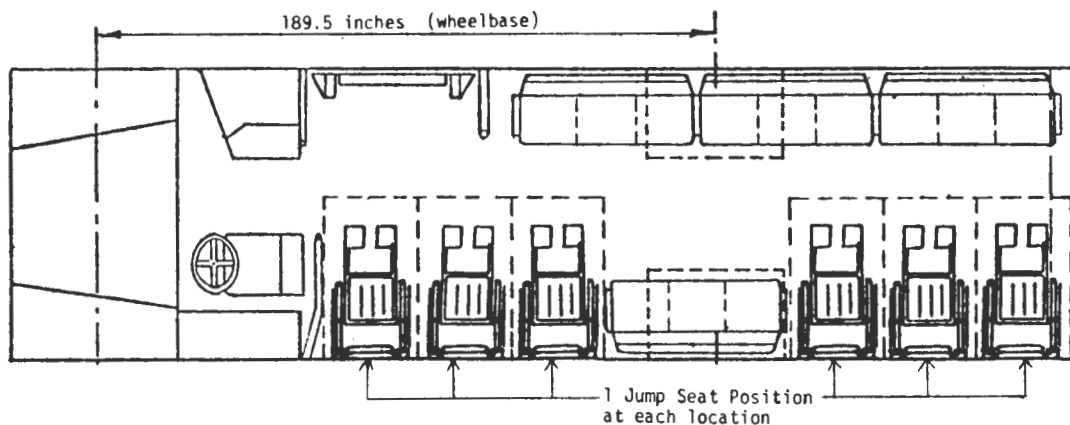

Note: This example provides 12 passenger seating positions and 6 wheelchair positions.

AVAILABLE FLOOR PLANS
(Light Buses)

BB-7-8

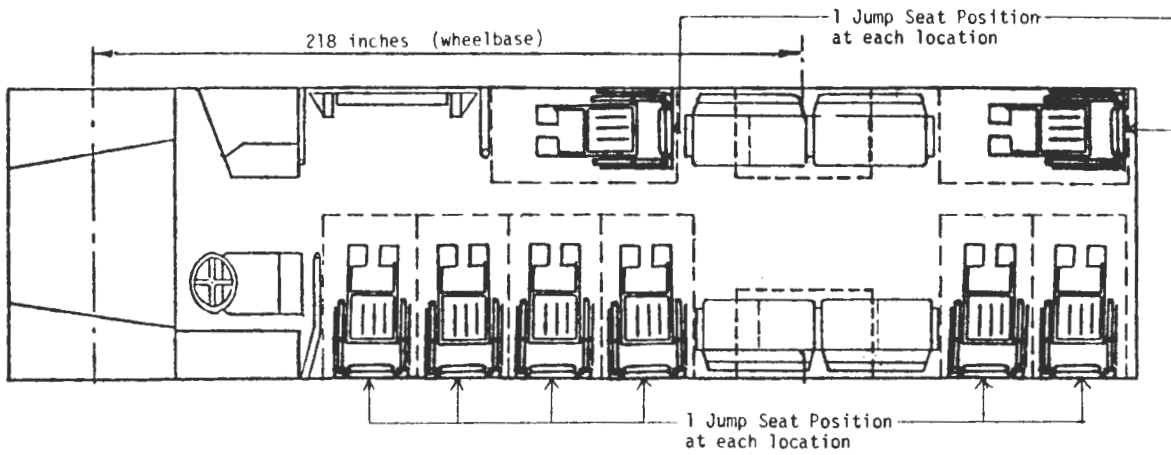

Note: This example provides 8 regular passenger seating positions and 8 wheelchair positions.

III-C. BUS SERIES

**3. LIGHT TRANSIT BUS
(CATEGORY C BUS)**

Light Transit Bus (Bus, Category "C")

The light transit bus will be a small (17 passenger) size vehicle built on a commercial van cutaway chassis. The bus will be of the type normally suited for social service agency transportation. The vehicle body will be a body manufactured by a body manufacturer for bus application, not "converted" to a bus from a sports van, passenger van, delivery vehicle or recreational vehicle.

For a small bus the interior will be spacious, with a minimum headroom (inside body height) of 73" and an interior width of 90". Adult-sized seating will be provided with adequate room for maneuvering of wheelchairs (if wheelchair transportation is chosen as an option) and ambulatory passengers at the same time. A minimum 16" aisle will be a standard feature.

The exterior appearance will be pleasing, with the side passenger windows being of the horizontal sliding type and the front end being "snub nosed." The rear end treatment will create a pleasing appearance when viewed from that direction since there will be no rear emergency exit door. Instead, the rear of the bus will be equipped with one to three windows, one of which must be of the emergency exit type. All federal safety exit requirements will be satisfied by requiring an adequate number of side windows to be of the emergency exit type.

Some standard features of the light transit bus include:

- Automatic transmission
- Power brakes
- Power steering
- Low first step height
- Jack and lug wrench
- Spare wheel and tire (not mounted on vehicle)
- Undercoating
- Emergency rear exit window
- Rubber floor covering
- Transit-type passenger windows
- Seat belts (may not be provided with the optional custom seats)
- Stanchions and grab rails
- On those types of vehicles with wheelchair lifts, included would be wheelchair locks and wheelchair occupant restraint systems
- Choice of manufacturer's standard colors
- Left and right hand outside mirrors with spot mirrors

This is a new series of buses, offered for the first time in Ohio's UMTA Section 16(b)(2) Program. However, the specifications will be written to obtain the smallest bus of various school bus manufacturers' lines. Examples of these buses are:

1. The Wayne "Chaperone"
2. The Bluebird "Microbird"
3. The Thomas "Minotour"
4. The Ward "Vanguard"

The standard seats provided may be of the type normally provided in school buses or may be of a type with a more pleasing appearance than school bus seats; according to which manufacturer is the successful bidder. However, custom seats are available as an extra cost option. An automatic transmission will be provided, making driving of the bus easier. Also, power steering and power brakes are standard features making handling of the bus easy, regardless of the physical strength of the driver. The "ride" will be about the same as a large passenger van, however, the padding and construction of the seats will directly effect the softness of the "ride."

The bus may be equipped with a wheelchair lift and up to three wheelchair positions. A wheelchair securement system will be provided at each wheelchair position. The lift will be installed on the right (curb) side of the vehicle, forward of the rear wheels. A "rear of the vehicle" location of the wheelchair lift is not available in this series and should not be requested, even if the agency believes it has sufficient justification for a rear-mounted lift. A rear-mounted lift, if properly justified, may be requested on a Van "C" vehicle.

On those vehicles with a wheelchair lift, a jump seat option may be selected. The jump seat option will provide fold-down seats at the wheelchair positions (WCPs) for use when the WCPs are not occupied by a wheelchair. The use of the jump seats will increase the seating capacity of the vehicle when the WCPs are not in use. The number of jump seat positions to be provided with each floor plan option is shown in the "Vehicles Available" table.

Ancillary equipment for these categories of vehicles is listed below. Illustrations showing various types of buses with and without lifts, and example floor plans for this series are shown on the following pages. Descriptive material for ancillary equipment is shown in Section IV. Cost Estimates are given in Section V, a separately published supplement.

Vehicle Category: Light Transit Bus (Bus "C")Vehicles Available:

<u>Vehicle Designation</u>	<u>Adult Seating</u> (1)	<u>Lift Provided?</u>	<u>Number</u> (2) <u>of WCPs</u>	<u>Number</u> (3) <u>of JSPs</u>
BC-17-0	17	No	0	0
BC-11-1	11	Yes	1	1
BC- 9-2	9	Yes	2	2
BC- 7-3	7	Yes	3	4

(1) Regular Adult Seating Capacity (the driver is not included in this total nor are the jump seat positions).

(2) WCPs = Wheelchair Positions provided on vehicle.

(3) JSPs = Jump Seat Positions. This column indicates the number of jump seat positions that will be provided for this vehicle if the Jump Seat Option is chosen. Jump seat locations are shown on the floor plan drawings.

Colors Available:

The colors listed below are generic colors available in the Bus series. Please indicate on the application the color desired for your vehicle. The purchase order, written after the make of the vehicle is determined via the bidding process, will specify the brand-name color most closely matching the generic color chosen.

- | | |
|----------------------|---------------|
| 1. White | 6. Dark Brown |
| 2. Black | 7. Light Blue |
| 3. Red | 8. Dark Blue |
| 4. Beige (Off-White) | 9. Dark Green |
| 5. Tan (Light Brown) | 10. Silver |

Floor Plans Available:

Drawings of example floor plan layouts for this category of buses are shown following the text of this section. These floor plans are intended as guides to the manufacturer. In most cases, the supplied vehicle will furnish a floor plan similar to the example. However, there may be some variances, according to the manufacturer, because of the locations of the wheelwell covers in relation to the rear of the bus. Several floor plans may provide one more seat than the minimum specified to make more efficient use of available space.

Ancillary Equipment (Provided):

The following equipment will be provided on each vehicle and no additional action is required by the agency.

1. Locking Front Passenger Entrance Door
2. Locking Hand Throttle
3. Power Steering and Power Brakes
4. Automatic Transmission
5. Heavy-duty suspension system
6. Large Battery and Alternator
 - a. Buses without air conditioner or wheelchair lift will provide, as minimums, an 80 amp-hour battery and a 90 amp alternator
 - b. Buses with air conditioner and/or wheelchair lift will provide, as minimums, a 150 amp-hour battery and a 130 amp alternator
7. Large Fuel Tank (total capacity of at least 30 U.S. gallons)
8. Emergency Equipment
9. Undercoating
10. Seat Belts (driver and all passengers)
11. Rear Auxiliary Heater
12. Tinted Glass and Windshield and all Windows

Ancillary Equipment (Optional):

The following equipment is available for each vehicle as an option. The agency must specify in its application what options are desired. These options will cost extra; and estimated prices are given in Section V, a separately published supplement.

1. Wheelchair Lift (includes wheelchair securement system and wheelchair occupant restraint system)
2. Jump Seat (fold-down seats at a wheelchair position to provide regular seating when wheelchairs are not present)
3. Custom Seats (deluxe passenger seats)
4. Air Conditioning (front and rear)
5. Radial Tires
6. Two-way FM Radio (VHF-low, VHF-high or UHF band) Mobile Units
7. Driver Hand Controls (for operation of the vehicle)
8. Wheelchair Accessibility Symbol (on outside of vehicle)

Unavailable Ancillary Equipment:

The following equipment is not available through this program and should not be requested.

1. Wheelchair ramp (instead of a wheelchair lift)
2. Rear-mounted wheelchair lift
3. Overhead flashing lights
4. Luggage Rack (interior or exterior)
5. Logos painted on the side of the vehicle
6. CB radio, commercial band radio, or tape player
7. Special or fancy wheelcovers
8. Special paint job



ILLUSTRATION 40 - LIGHT TRANSIT BUS (CATEGORY C BUS)

BLUE BIRD MICROBIRD

Source: Blue Bird Co.



ILLUSTRATION 41 - LIGHT TRANSIT BUS (CATEGORY C BUS)

THOMAS MINOTOUR

Source: Thomas Built Buses

III-C-40



ILLUSTRATION 42 - LIGHT TRANSIT BUS (CATEGORY C BUS)

THOMAS MINOTOUR WITH WHEELCHAIR LIFT

Source: Thomas Build Buses



III-C-42

ILLUSTRATION 43 - LIGHT TRANSIT BUS (CATEGORY C BUS)

WARD VANGUARD

Source: American Transportation Corp.



ILLUSTRATION 44 - LIGHT TRANSIT BUS (CATEGORY C BUS)

WAYNE CHAPERONE

Source: Wayne Corporation

III-C-43

AVAILABLE FLOOR PLANS
(Light Transit Buses)

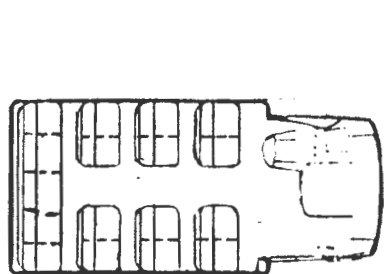

BC-17-0

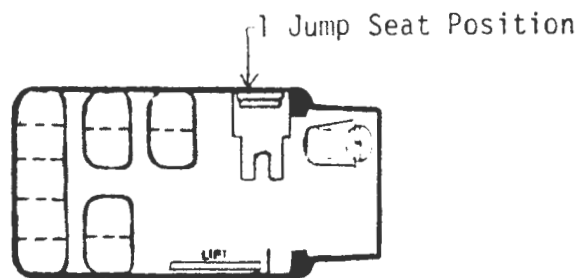

BC-11-1

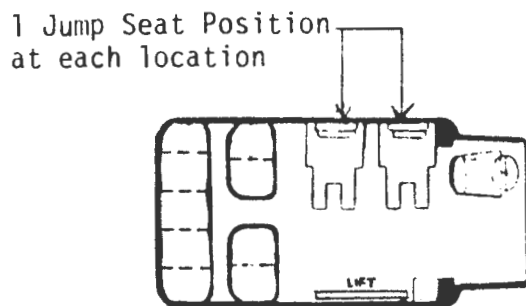

BC-9-2

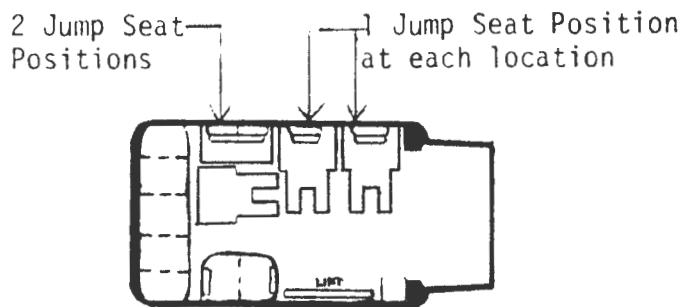

BC-7-3

IV. TYPES OF ANCILLARY EQUIPMENT AVAILABLE

TABLE OF CONTENTS - SECTION IV

	<u>Page</u>
IV. <u>TYPES OF ANCILLARY EQUIPMENT AVAILABLE</u>	IV-1
A. <u>Emergency Equipment</u>	IV-3
1. Illustration 45 - First Aid Kits	IV-6
B. <u>Passenger Assist Stanchion</u>	IV-7
1. Illustration 46 - Typical Passenger Assist Stanchion	IV-8
2. Illustration 47 - Typical Passenger Assist Stanchion Diagram	IV-9
C. <u>Rust Proofing</u>	IV-10
1. Illustration 48 - Ziebert Rust Proofing	IV-11
2. Illustration 49 - Quaker State Metal-Gard Rust Protection	IV-12
D. <u>Wheelchair Lifts</u>	IV-13
1. Illustration 50 - Bud Lift	IV-14
2. Illustration 51 - REB Lift	IV-15
3. Illustration 52 - Braun Lift	IV-16
4. Illustration 53 - Braun Lift Operation	IV-17
5. Illustration 54 - Diagram of Braun Lift	IV-18
6. Illustration 55 - Collins Lift	IV-19
7. Illustration 56 - Collins Lift Operation	IV-20
8. Illustration 57 - Coach and Equipment Lift	IV-21
E. <u>Wheelchair Ramps</u>	IV-22
1. Illustration 58 - Collins Econ-O-Ramp Operation	IV-23
2. Illustration 59 - Collins Econ-O-Ramp Diagram	IV-24
F. <u>Wheelchair Securement Systems</u>	IV-25
1. Illustration 60 - Aeroquip Wheelchair Securement System - Belts	IV-29
2. Illustration 61 - Collins Wheelchair Securement System - Locks	IV-30
3. Illustration 62 - Collins Wheelchair Securement System - Locks	IV-31
4. Illustration 63 - Bud Industries Wheelchair Securement System - Locks	IV-32
G. <u>Restraining Devices for Wheelchair Occupants</u>	IV-33
1. Illustration 64 - Velcro Safety Belt	IV-34
2. Illustration 65 - Auto Type Seat Belt	IV-35
H. <u>Jump Seats</u>	IV-36
1. Illustration 66 - Ferno-Washington Jump Seat	IV-37
2. Illustration 67 - Ferno-Washington Jump Seat Diagram	IV-38
3. Illustration 68 - OTACO Jump Seat	IV-39
4. Illustration 69 - Collins Flip Seat	IV-40
5. Illustration 70 - Collins Jump Seat, Installed	IV-41

TABLE OF CONTENTS, CONT'D.

	<u>Page</u>
I. <u>Running Boards</u>	IV-42
1. Illustration 71 - E.Z. Sider Running Board	IV-44
2. Illustration 72 - BIMCO Running Board	IV-45
3. Illustration 73 - Installed Running Board	IV-46
J. <u>Two-Way FM Radios</u>	IV-47
1. Illustration 74 - General Electric Two-Way Radio	IV-49
2. Illustration 75 - Motorola Two-Way Radio	IV-50
3. Illustration 76 - RCA Two-Way Radio	IV-51
4. Illustration 77 - Regency Two-Way Radio	IV-52
K. <u>Handicapped Driver Assist Devices</u>	IV-53
1. Illustration 78 - Driving Aids	IV-54
2. Illustration 79 - Slim Line Control	IV-55
L. <u>Air Conditioning</u>	IV-56
1. Illustration 80 - Typical Rear Unit Air Conditioner for Van "C"'s and LTVs	IV-58
2. Illustration 81 - Typical Air Conditioners for LTVs and Buses	IV-59
M. <u>Radial Tires</u>	IV-61
N. <u>Wheelchair Accessibility Symbol</u>	IV-62
1. Illustration 82 - Wheelchair Accessibility Symbol	IV-63
O. <u>Custom Seats</u>	IV-64
1. Illustration 83 - Typical Standard Passenger Seat (Regular Seat)	IV-65
2. Illustration 84 - Standard Fiberglass Shell Passenger Seat (Regular Seats)	IV-66
3. Illustration 85 - Typical Standard Passenger Seats (Regular Seats)	IV-67
4. Illustration 86 - Typical Custom Seats	IV-68
5. Illustration 87 - Typical Custom Seats	IV-69
6. Illustration 88 - Typical Custom Seats	IV-70

IV. TYPES OF ANCILLARY EQUIPMENT AVAILABLE

A variety of ancillary equipment has been added to the standard vehicle in each series or is available to be added as an optional choice of the agency. This equipment is intended to: make the vehicle safer; make it easier to enter or exit; make it more comfortable; provide for the safe transportation of wheelchair passengers; provide for increased seating capacity; to improve the tire life; to protect the vehicle from rust; to provide two-way communications; and to allow a handicapped person to drive the vehicle.

The following items will be provided on specified vehicles (see descriptive material in Section III) as standard equipment and no additional action is required by the agency.

- A. EMERGENCY EQUIPMENT - See the following pages for a list showing the types of equipment included on each vehicle and an illustration showing typical first aid kits that may be provided.
- B. PASSENGER ASSIST STANCHION - See the following pages for sample specifications for this item plus illustrations showing this equipment.
- C. RUSTPROOFING - See the following pages for illustrations of this item.

The following items are available on specified vehicles (see descriptive material in Section III) as optional equipment. This equipment will be furnished at additional costs over the basic vehicle (basic vehicle cost includes specified additional standard ancillary equipment). The agency must specify on its application what optional equipment, if any, is desired. Estimated costs for all optional ancillary equipment is given in Section V, a separately published supplement. Standard specifications for each item are included herein plus illustrations showing the equipment. The illustrations are for informational purposes only. While the supplied equipment will be similar to that shown, it may be somewhat different as long as it meets the specifications in all respects. Also, equipment by various manufacturers is shown to illustrate typical equipment; the provided equipment may be by a manufacturer whose equipment is not illustrated.

- D. WHEELCHAIR LIFTS
- E. WHEELCHAIR RAMPS
- F. WHEELCHAIR SECUREMENT SYSTEMS

- G. RESTRAINING DEVICES FOR WHEELCHAIR OCCUPANTS
- H. JUMP SEATS
- I. RUNNING BOARDS
- J. TWO-WAY FM RADIOS
- K. HANDICAPPED DRIVER ASSIST DEVICES
- L. AIR CONDITIONING
- M. RADIAL TIRES
- N. WHEELCHAIR ACCESSIBILITY SYMBOL
- O. CUSTOM SEATS

IV-A. EMERGENCY EQUIPMENT

A. EMERGENCY EQUIPMENT:

1. All vans of Category "A" and Category "B" shall be equipped with the following:
 - a. Six 30-minute road flares.
 - b. Three warning reflectors mounted on stands.
 - c. A dry chemical fire extinguisher of at least 5 pound capacity, which shall be bracket-mounted and easily accessible to the driver.
 - d. A first aid kit with a minimum of ten different units, which shall be mounted in a location easily accessible to the driver.

The mounted location of any of the above equipment shall not interfere with passengers' limbs or placement of feet. Also, none of the equipment shall be mounted on a door.

2. All vans of Category "C" shall be equipped with the following:
 - a. WARNING DEVICES: Six (6) 30-minute road flares and three portable warning reflectors mounted on stands shall be furnished.
 - b. FIRE EXTINGUISHER: One dry chemical fire extinguisher of at least five (5) pound capacity shall be furnished and shall be bracket mounted and easily accessible to the driver.
 - c. FIRST AID KIT: A first aid kit with a minimum of ten (10) different units (each unit shall be of a different type from every other unit) shall be furnished and mounted in a location easily accessible to the driver.
 - d. LUG WRENCH: A lug wrench of the proper size and type to remove wheels from the van shall be furnished.
 - e. JACK: A jack of sufficient strength to safely lift the vehicle for tire changing shall be furnished.

The mounted location of any of the above equipment shall not interfere with passengers' limbs or placement of feet or interfere with movement of passengers and/or wheelchairs within the vehicle. Also, none of the equipment shall be mounted on a door.

3. All Light Transit Vehicles (LTV) and Light Transit Buses (Bus, Category C) shall be equipped with the following:

- a. WARNING DEVICES: Six (6) 30-minute road flares and three portable warning reflectors mountable on stands (provided) shall be furnished.
- b. FIRE EXTINGUISHER: One dry chemical fire extinguisher of at least five (5) pound capacity shall be furnished and shall be bracket mounted and easily accessible to the driver.
- c. FIRST AID KIT: A first aid kit with a minimum of ten (10) different units (each unit shall be of a different type from every other unit) shall be furnished and mounted in a location easily accessible to the driver.
- d. LUG WRENCH: A lug wrench of the proper size and type to remove wheels from the vehicle shall be furnished.

The mounted location of any of the above equipment shall not interfere with passengers' limbs or placement of feet or interfere with movement of passengers and/or wheelchairs within the vehicle. Also, none of the equipment shall be mounted on a door.

- 4. All Modified School Buses (Bus, Category A) shall be equipped with the following:
 - a. Fire extinguisher - Bus shall be equipped with at least one dry-chemical type fire extinguisher of at least five-pound capacity, twenty B.C. rating, mounted in a quick release type bracket and easily accessible from the driver's compartment. The extinguisher is to be equipped with a dial type, graduated gauge, which indicates loss of pressure. Fire extinguisher shall be of the type that permits the dry-chemical case to be refilled by ordinary procedures.
 - b. First aid kits shall be dust-proof, plainly labeled and mounted in a location easily accessible to the driver and shall have a minimum of sixteen units.

Contents of sixteen-unit first aid kit:

- 2 units - 1" adhesive compress
- 2 units - 2" bandage compress
- 1 unit - 3" bandage compress
- 1 unit - 4" bandage compress
- 1 unit - 3" x 3" plain gauze pads
- 1 unit - 4" gauze roller bandage
- 2 units - plain absorbent gauze - 1/2 square yard
- 2 units - plain absorbent gauze - 24" x 72"

3 units - triangular bandages
1 unit - scissors, tweezers

- c. Reflectors - Three triangle reflectors with weighted stands, properly encased for easy storage. Six fuses, thirty-minute type shall be encased with the triangle reflectors. The triangle reflectors shall meet FMVSS 125. The reflectors and fuses shall be encased together in a heavy duty container. A lockable metal bracket shall be provided to hold these items. The bracket shall be mounted within easy access of the driver.
- d. Wrecking bar - One twenty-four inch wrecking bar.
5. All Light Buses (Bus, Category B) shall be equipped with the following:

EMERGENCY EQUIPMENT: The vendor shall equip each vehicle with the following:

- (1) Six 30-minute road flares.
- (2) Three warning reflectors mounted on stands.
- (3) A dry chemical fire extinguisher of at least 5 pound capacity, which shall be bracket-mounted and easily accessible to the driver.
- (4) A first aid kit with a minimum of sixteen different units, which shall be mounted in a location easily accessible to the driver.
- (5) A lug wrench.

The mounted location of any of the above equipment shall not interfere with passengers' limbs or the placement of feet. Also, none of the equipment shall be mounted on a door.

An illustration showing typical first aid kits is presented on the following page.



ILLUSTRATION 45 - FIRST AID KITS

Source: Acme Cotton Products Company, Inc.

IV-B. PASSENGER ASSIST STANCHION

B. PASSENGER ASSIST STANCHION:

All vans of Category "A" (Standard Van) and Category "B" (Standard Van with Ramp) shall be equipped with a passenger assist stanchion. The following specification is used to procure this equipment:

PASSENGER ASSIST STANCHION: A vertical stanchion shall be installed inside the van adjacent to the front edge of the side (passengers') door entranceway. The stanchion shall extend from the surface of the side door's step to the body frame structural member over the doorway. Care should be taken in placing the stanchion so that it does not overly protrude into the entranceway, thereby obstructing traffic. The stanchion should be approximately 2" clear of the side of the entranceway. The stanchion shall be of minimum 1 1/4" outside diameter stainless steel tubing.

The stanchion shall be mounted securely to the vehicle. Method of mounting shall be as determined by the vendor according to the body conformation of the van (e.g., top may curve in further than step projects into interior). However, the strength (tubing to resist deflection and mounting to resist pulling away from the body) of the stanchion shall be sufficient to withstand the force exerted by a large heavy person using the stanchion to help pull himself up and into the van from the ground level.

The vendor shall submit a description of the stanchion, including physical location, and mounting procedures with his bid. Formal drawings need not be submitted; clear hand drawn sketches will be acceptable.

An illustration of a typical passenger assist stanchion for a standard van is shown on the following page.



ILLUSTRATION 46 - TYPICAL PASSENGER
ASSIST STANCHION

Source: Elderly United of Springfield and Clark County

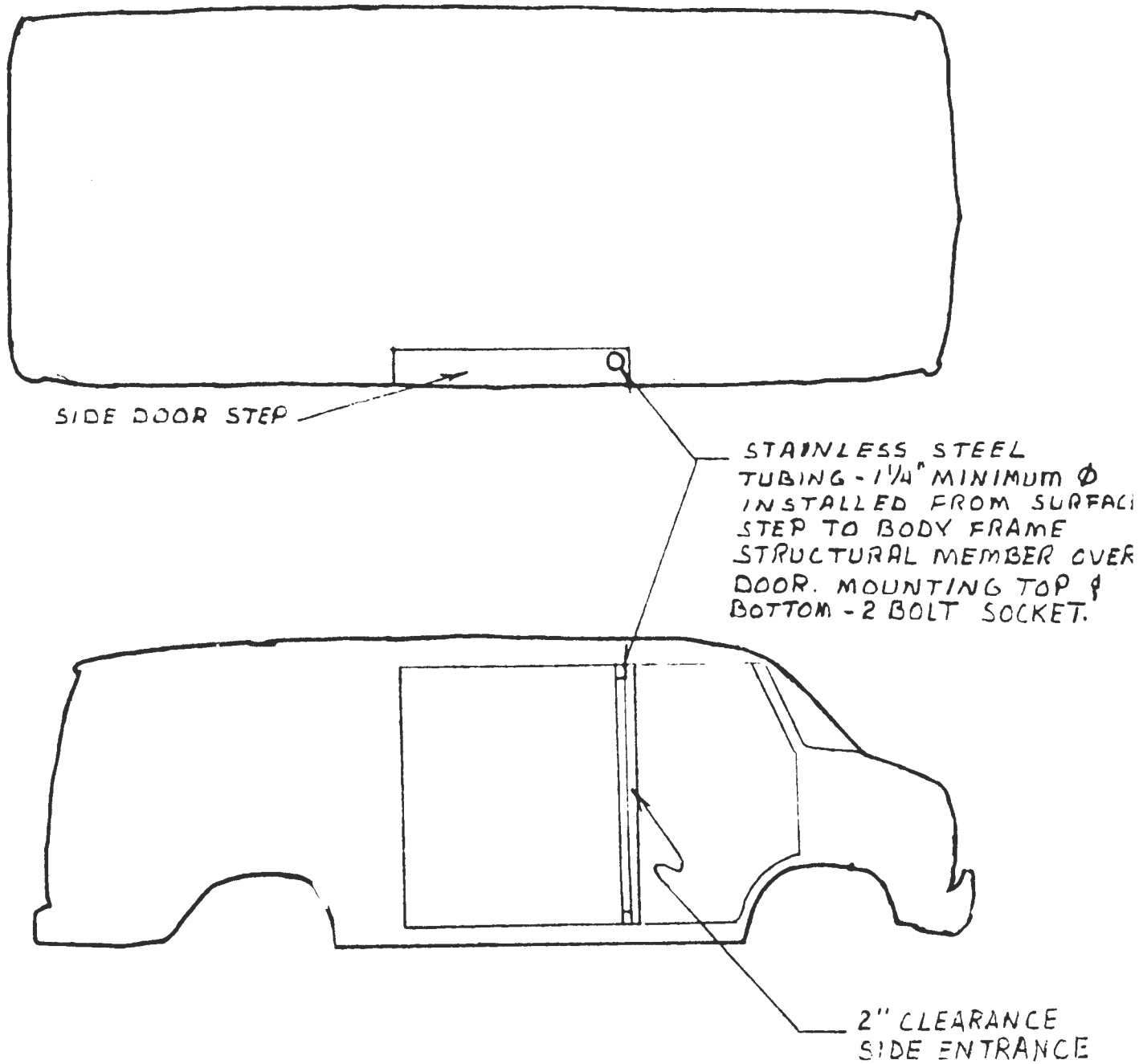

PASSENGER ASSIST STANCHION

ILLUSTRATION 47 - TYPICAL PASSENGER ASSIST STANCHION DIAGRAM

Source: The Braun Corp.

IV-C. RUSTPROOFING

C. RUSTPROOFING:

Rustproofing will be provided, in addition to the undercoating, on all vehicles of the van series (Van "A", "B" and "C") and the LTV series. Rustproofing will not be provided, nor will it be available as an option, on the bus series (Bus "A", "B", and "C").

Rustproofing involves applying a compound or sealant to the interior surfaces of the vehicle to retard rusting of the metal. Seams are penetrated by the compound. Several types of rustproofing systems will do a satisfactory job. However, any system must, at a minimum, be equivalent or better than the following systems:

1. Ziebart
2. Quaker State

Reproductions of pamphlets showing the above systems as applied to passenger automobiles are included in the following pages.

Ziebart Rust Protection. Proven to give the rust protection you pay for.

In truth, without Ziebart Proven Rust Protection, your new car will never look as good as it does right now.

Ziebart Proven Rust Protection means what it says. Top to bottom, bumper to bumper protection against rust. Protection that is proven on 6 million cars all over the world. Protection in the form

of specially formulated sealants, expertly applied by factory trained technicians, using exclusive Ziebart Microfilm diagrams showing exactly where the protection is needed and how to get there.

Protection that is warranted for as long as you own your new car. Now, more than ever, rust protection is a necessity. Especially since thinner metals are being used and more corrosive, acid-creating pollutants are

present on the roads and in the air than ever before. But not just any rust protection. Ziebart Proven Rust Protection. The brand that's designed to work right the first time...to give you the rust protection you pay for.



MICROFILM APPLICATION DIAGRAMS
There's one for most U.S. and import cars, trucks and vans. Shows exactly where Rust Protection is needed and how to get there.

PILLARS
Seams; all pillar bases and internal dog leg sections.

REAR DISK LID
Interior of axle.

TRUNK AND WINDSHIELD
Trunk floor seams; trunk lid; windshield; rear window

TRUNK
Trunk floor seams; trunk lid; trunk lid

HOOD
Interior of forward lip seam.

FRONT
Critical areas including ground-water

ROCKER PANELS
All internal surfaces; fender-in sections.

QUARTER PANELS
Total coverage of all critical inside surfaces including seams and outer walls of wheel wells.

TAILLIGHT AREA
Seams; housing inside trunk when sealed for.

ENGINE COMPARTMENT
Seams and base of subframe; water pump; valve cover; battery supports.

FRONT END
Total coverage of all critical areas including seams and subframe supports.

UNDERBODY
Lower rocker panel sections; lower floor supports; frame rails; undertray; gas tank; rear gas tank line; gas lines.

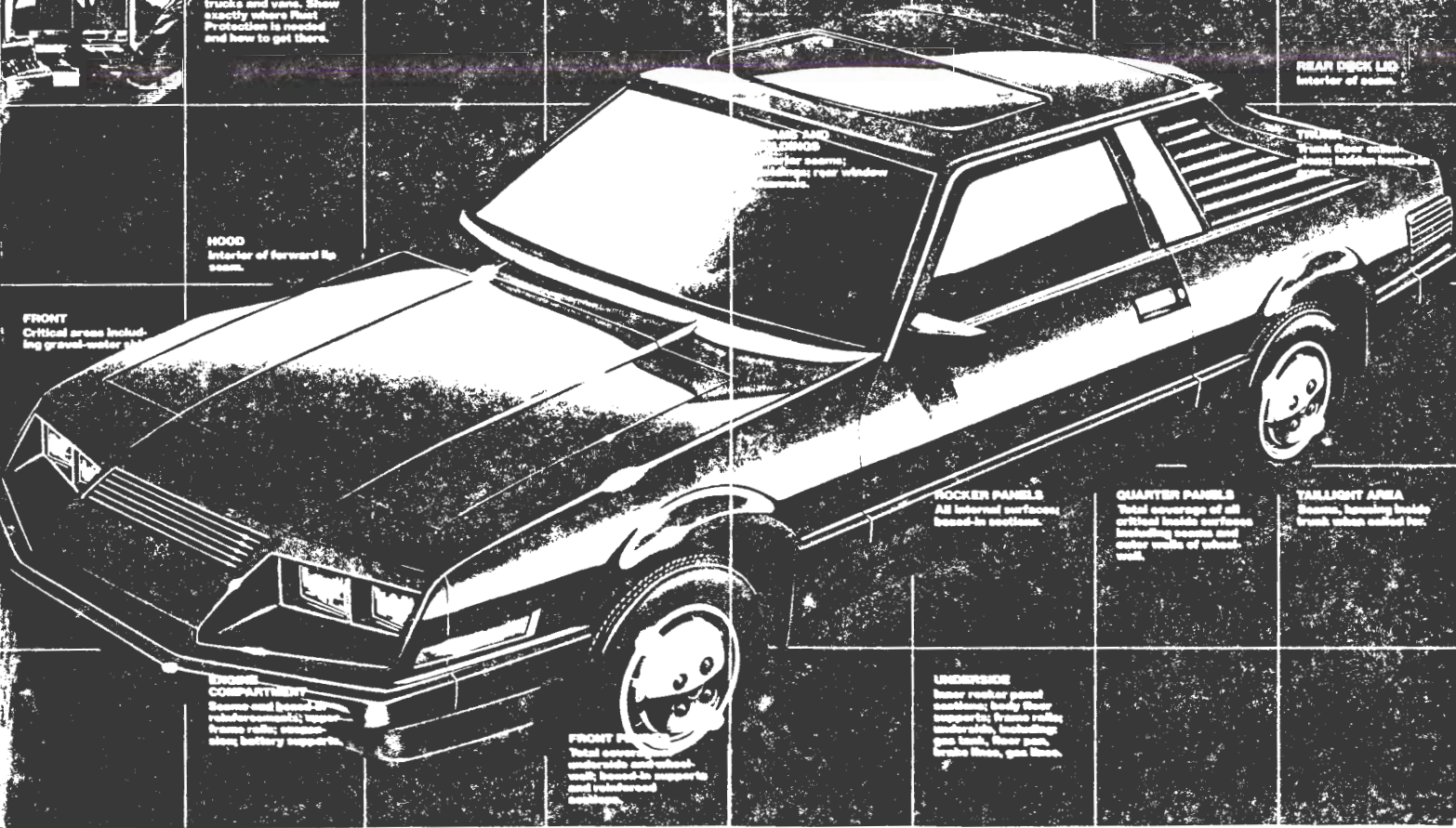

ILLUSTRATION 48 - ZIEBART RUST PROOFING

Source: Ziebart Rust Proofing Co.

Quaker State Rust Protection: Guaranteed* as long as you own your car

Metal-Gard preserves these 13 critical areas of your new car.

*See Warranty for details.

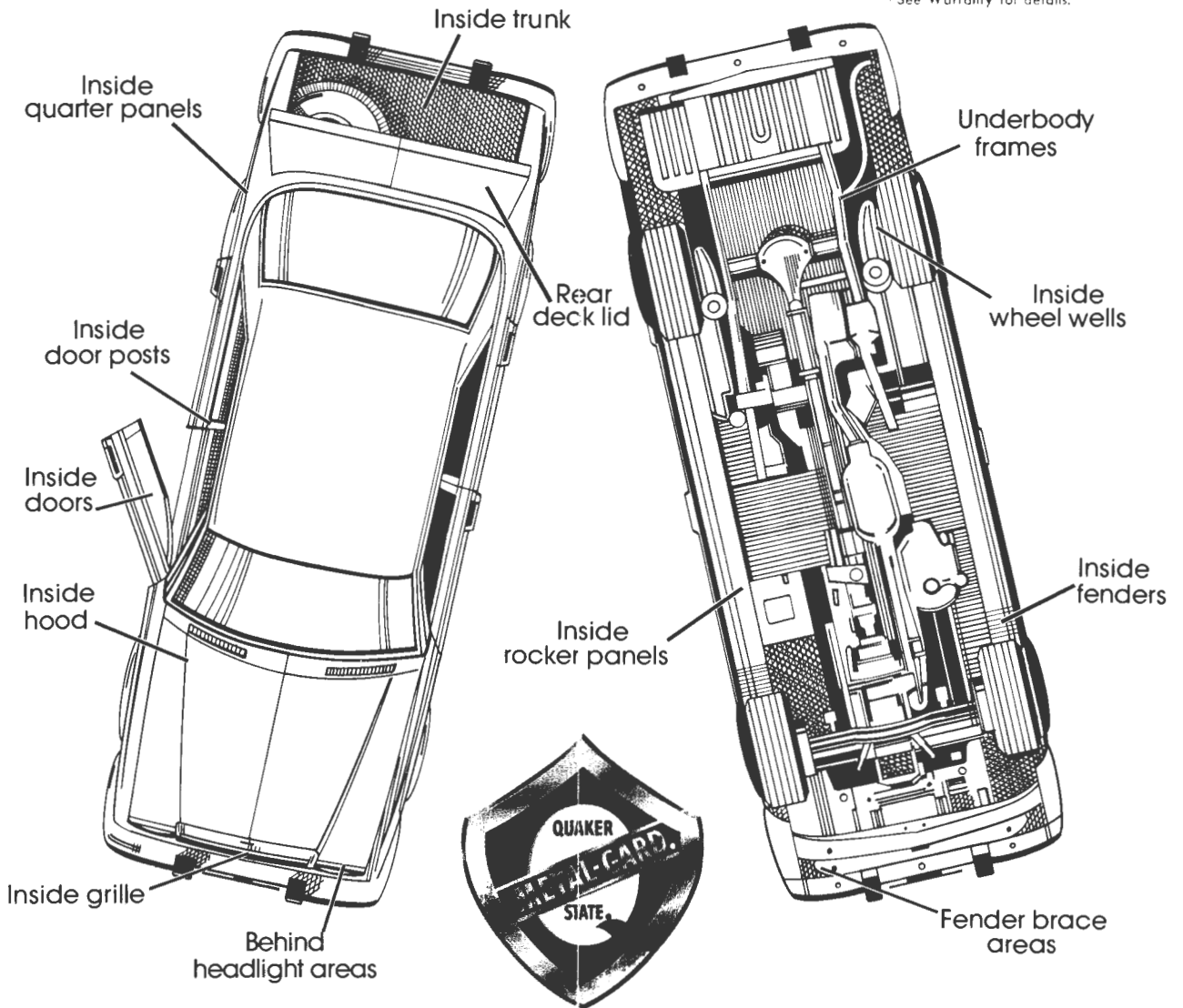

TRUST US AGAINST RUST QUAKER STATE HELPS CARS LAST

ILLUSTRATION 49 - QUAKER STATE METAL-GARD RUST PROTECTION

Source: Quaker State Motor Oil Co.

IV-D. WHEELCHAIR LIFTS

D. WHEELCHAIR LIFTS:

For vehicles on which a lift is permitted (Van "C"; LTV; Buses "A", "B" and "C") the procurement specifications call for a platform type lift. The specifications are rather long and will not be repeated herein. However, they call for the following features at a minimum:

- a. Support 1000 pounds; raise or lower 700 pounds
- b. Power operated, except down movement of platform may be gravity
- c. Portable and stationary controls
- d. Lift opening of 57.5 inches, minimum
- e. Platform of 26.5" wide (min.) by 36" long (min.)
- f. Protective flange on both sides of platform
- g. Hinged bar or panel across outward-facing edge of platform
- h. Automatic handrail on one side of platform

Illustrations of several types of wheelchair lifts are shown on the following pages.



ILLUSTRATION 50 - BUD LIFT

Source: Bud Industries

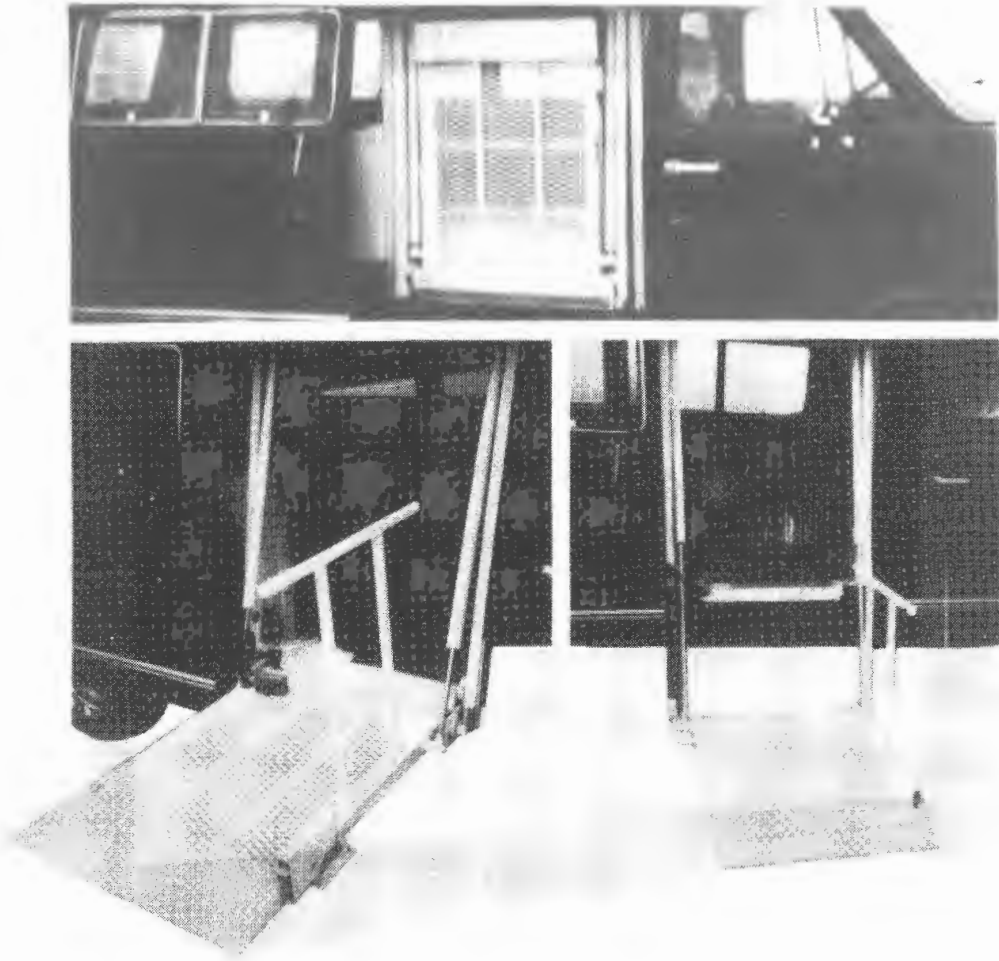

ILLUSTRATION 51 - REB LIFT

Source: REB Manufacturing, Inc.



ILLUSTRATION 52 - BRAUN LIFT

Source: The Braun Corporation



ILLUSTRATION 53 - BRAUN LIFT OPERATION

Source: The Braun Corporation

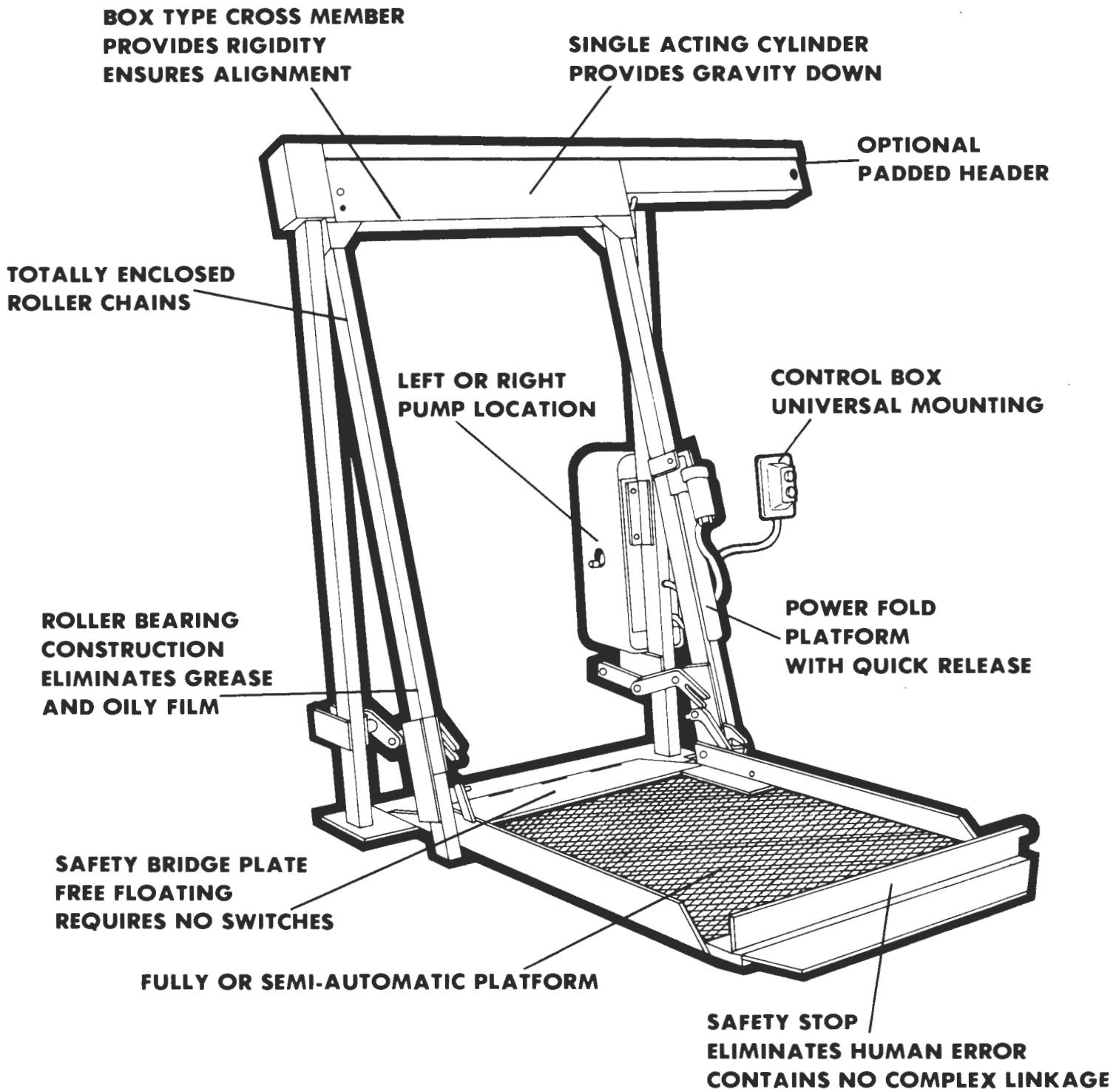
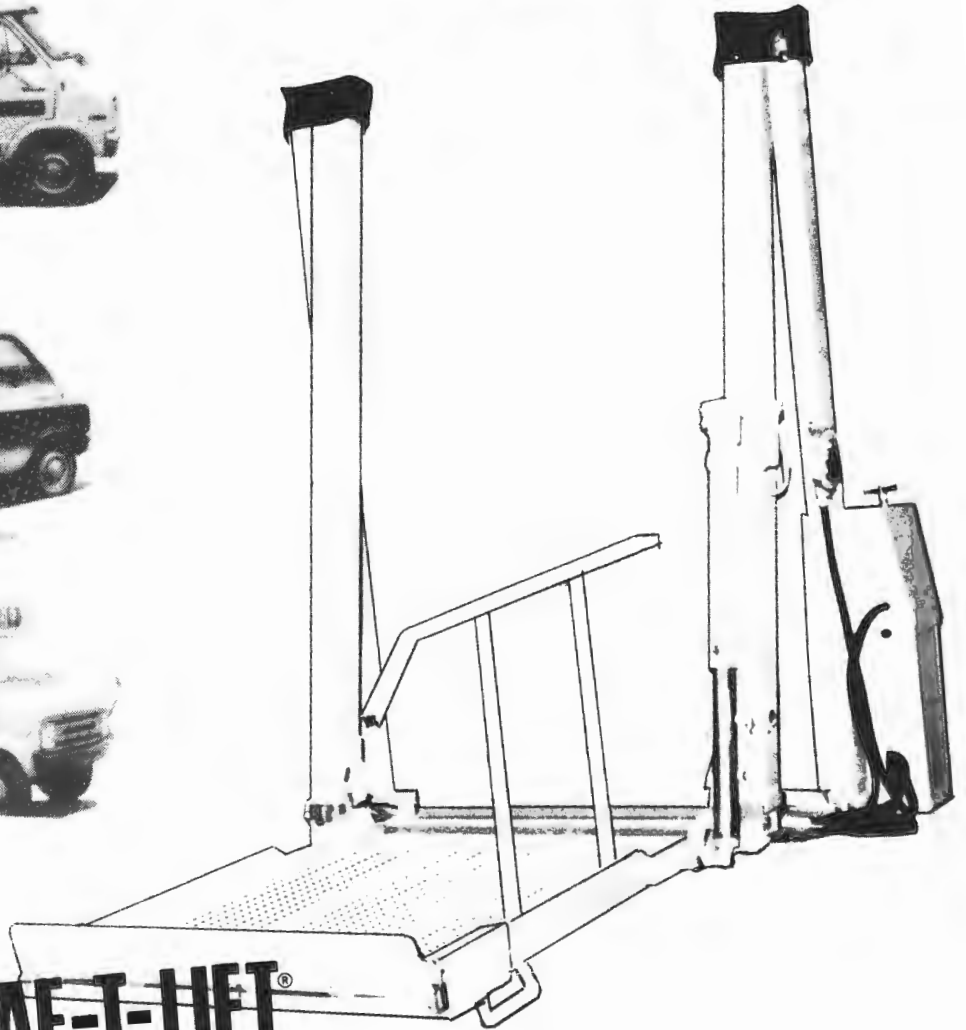

ILLUSTRATION 54 - DIAGRAM OF BRAUN LIFT

Source: The Braun Corporation

SAF-T-LIFT[®] by COLLINS[®]



COLLINS

SAF-T-LIFT[®]

ILLUSTRATION 55 - COLLINS LIFT
Source: Collins Industries, Inc.



ILLUSTRATION 56 - COLLINS LIFT OPERATION

Source: Collins Industries, Inc.

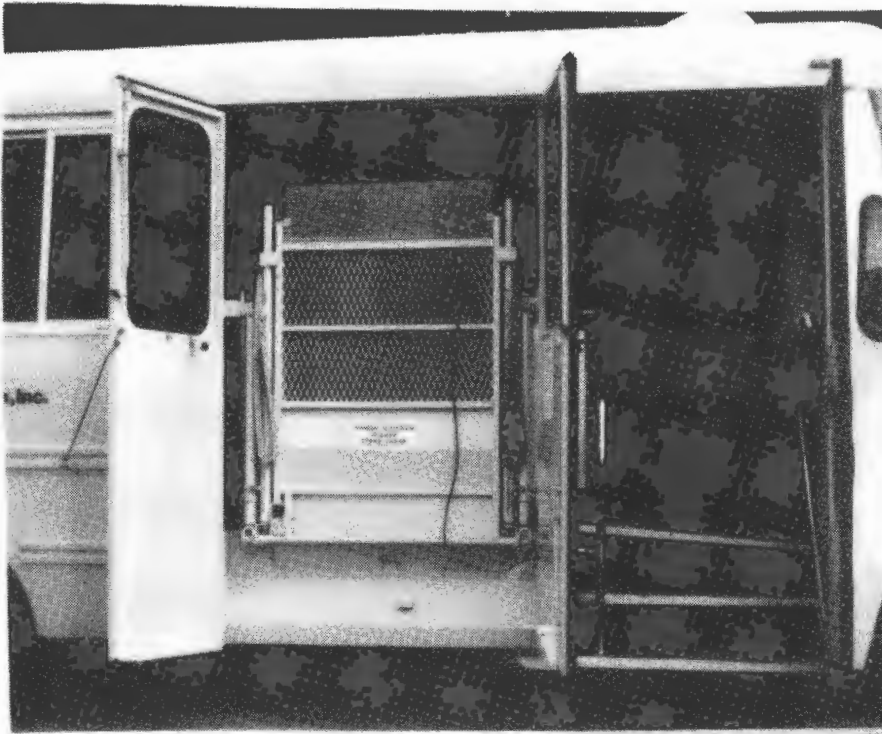

ILLUSTRATION 57 - COACH AND EQUIPMENT LIFT
Source: Coach and Equipment Sales Corporation

IV-E. WHEELCHAIR RAMPS

E. WHEELCHAIR RAMPS:

Wheelchair ramps are available on Category "B" Vans, only. The specification used for procurement of the ramp is reproduced below.

RAMP: The ramp shall be installed on the rear of the vehicle and properly adjusted to operate easily. The ramp shall be permanently bolted to the inside of the van at the rear door(s). The ramp shall be of the type which folds in the middle, and which is easily folded and unfolded manually. To assist in this manual operation, handles shall be provided on the side of the ramp and the ramp folding mechanism shall be spring-assisted. When folded up in its storage position, all components of the ramp mechanism shall be located inside the vehicle and it shall be possible to close the rear door(s) of the van. The ramp shall be secure and stationary when folded up in its storage position with the van's rear door(s) closed.

With the van's rear door(s) opened and the ramp unfolded, the ramp shall provide a smooth inclined surface from the ground to the van floor level on which a wheelchair containing a handicapped person may be pushed from the ground level into the van or rolled out of the van down to ground level. The ramp shall have an extended length of at least 84 inches. The ramp shall have a clear width (inside to inside of edge flanges) of at least 28 inches. Protective edge flanges shall be provided on the ramp to prevent the wheels of a wheelchair from rolling off the edge of the ramp. No center steps or toe-cleats shall be provided.

The ramp shall be constructed of expanded metal and capable of supporting a load of at least 400 pounds.

The ramp will be automatically included on the vehicle if a Van Category B (VB-10-1) is selected by the agency.

Typical examples of the type of ramp procured by the above specifications are illustrated on the following pages.



ILLUSTRATION 58 - COLLINS ECON-O-RAMP OPERATION

Source: Collins Industries, Inc.

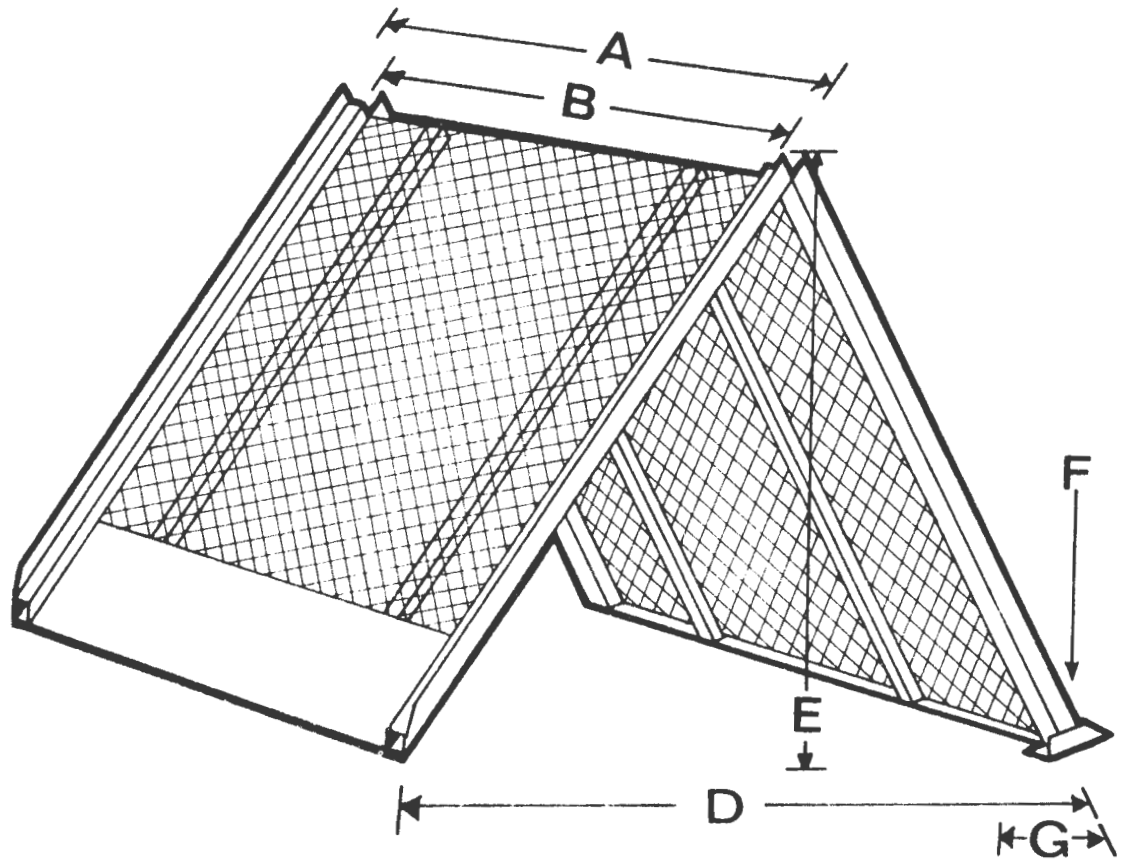

SPECIFICATIONS	OPTION W-12	OPTION W-12XL
A. OVERALL WIDTH	31.25 in.	31.25 in.
B. MAXIMUM TRACK WIDTH	29 in.	29 in.
C. MINIMUM TRACK WIDTH	None	None
D. EXTENDED LENGTH	88 in.	108.00 in.
E. CLOSED HEIGHT	44 in.	54.00 in.
F. METHOD OF ATTACHMENT	4 Bolts	4 Bolts
G. FOLDED AREA IN VAN	10 in.	10 in.
H. WEIGHT	75 lbs.	90 lbs.
I. LOAD CAPACITY	400 lbs.	400 lbs.
J. RELEASE MECHANISM	Spring loaded— Double Actuation	Spring loaded— Double Actuation
K. FOLD MECHANISM	Spring assisted	Spring assisted
L. CONSTRUCTION	10 gauge expanded metal over 1" square tubing frame.	10 gauge expanded metal over 1" square tubing frame.

ILLUSTRATION 59 - COLLINS ECON-O-RAMP DIAGRAM

Source: Collins Industries, Inc.

IV-F. WHEELCHAIR SECUREMENT SYSTEMS

F. WHEELCHAIR SECUREMENT SYSTEMS:

Three general types of wheelchair securement systems are used on vehicles in the ODOT program, as follows:

- (1) Wheelchair Locks. Where specified, wheelchair locks shall be used to secure the rear wheels of a wheelchair in the designated wheelchair position. These locks may be separate or in combination with a jump seat (see Section IV-H). Sample specifications for these locks follow.

WHEELCHAIR LOCKS: At each wheelchair position, a set of wheelchair locks shall be provided which will securely hold both rear wheels of the wheelchair in the wheelchair position while the vehicle is in motion. The wheelchair locks shall be capable of easily adjusting laterally without the use of tools to hold a wheelchair with a width from outside to outside of wheels and hand-rims of 26 inches and a wheelchair with a width from inside of wheels of 16.75 inches.

Currently, this system is specified for Buses, Types "A" and "B."

See the following illustrations for example of this system.

- (2) Belt-track System. Where specified, a four point belt-track attachment system shall be used to secure the wheelchair in the designated wheelchair position. The system shall be that manufactured by the Aeroquip Corporation, or an approved equal. Sample specifications for this system follow.

For Van "B" (all van B's have this system specified):

The system shall be composed of the following elements. A four point attachment system shall be used consisting of four separate belts with all necessary buckles, hardware, fittings and other parts to make it a complete wheelchair securement system. Two of the buckles shall be ratchet (tensioning) buckles. Three tracks (Aeroquip Series A or E, or equal) shall be placed parallel to each other on 15" centerline-to-centerline spacing and parallel to the sides of the van in the rear of the van between the wheelwell covers. The center track shall be placed on the centerline of the space between the rear wheelwell covers. Each track shall be approximately 62" long (the left and right tracks may be cut to avoid the bench seat floor fasteners, if necessary for clearance). The tracks shall be securely mounted to the floor of the vehicle in such a way as to insure the track will not pull away from the van floor or shift position under anticipated loads. Care should be taken to avoid damage to any of the vehicle's components

during installation of the wheelchair securement system. Particular care should be taken to avoid damage to the fuel tank(s) during and after installation of the floor tracks. One method which has been used to avoid damage is to remove the fuel tank(s) from the vehicle prior to drilling of the track bolt holes; to prevent puncturing of the tank(s). After bolting the tracks to the floor any excess bolt length should be cut off. Then the tanks can be remounted with consideration given to using wooden spacers, treated to resist rotting, between the underside of the floor and the top of the tank(s). The purpose for the spacers is to block the tank away from the floor to prevent the bolt ends and nuts from rubbing holes into the fuel tank. If removed, the fuel tank(s) should be reinstalled securely and safely. It should be noted that the method of installing the track is the sole responsibility of the vendor and he may use whatever method will obtain the required results.

In addition, provisions shall be made on the right side of the van (right rear inside corner) to hang the straps and buckles off the floor when they are not in use. This shall be accomplished by installing a piece of track, of the same type and model provided for the securement system, of appropriate length so that all the belts of the system can be attached to it. Also, the vendor shall provide with each van upon delivery a pamphlet, brochure or similar literature describing (and instructing) the use of the wheelchair securement system; and shall demonstrate to the recipient the proper method of using the system.

For Van "C" (Converted Van), LTV (Light Transit Vehicle) and Bus "C" (Light Transit Bus):

This system shall be composed of the following elements. At each wheelchair position (WCP) a four point attachment system shall be used consisting of four separate belts with all necessary buckles, hardware, fittings and other parts to make it a complete wheelchair securement system. Two of the buckles shall be ratchet (tensioning) buckles. A minimum of two tracks (Aeroquip Series A or E, or equal), each of sufficient length for proper attachment and positioning of the belts, shall be placed parallel to each other and perpendicular to the direction in which the WCP faces. The minimum length of each piece of floor track shall be 36 inches. The track at the rear of the WCP shall be located immediately to the rear of the rear wheels of the wheelchair when properly located in the WCP and the track at the front of the WCP shall be located immediately to the front of the wheels of the wheelchair (the distance between centerlines of the tracks shall be approximately 27 inches).

In addition, provisions shall be made, in the wheelchair position area, to hang the straps and buckles off the floor when they are not in use. The stored straps shall not interfere with passenger movement or sitting space. This shall be accomplished by installing a piece of track, of the same type and model provided for the securement system, of appropriate length so that all the belts of the system can be attached to it. Also, the vendor shall provide with each van upon delivery a pamphlet, brochure or similar literature describing (and instructing) the use of the wheelchair securement system and shall demonstrate to the recipient the proper method of using the system.

Note: Several of the optional floor plans will require two systems, this system and the system described below under (3), according to the location of the wheelchair position.

See the following illustrations for examples of this system.

- (3) **Combination System.** Where specified, a combination system will be provided to secure the wheelchair in the designated wheelchair position. The system shall be a combination of wheelchair locks for the rear wheels and a belt-track system for the front of the wheelchair.

Currently, this system is designated for certain wheelchair positions in Van "C" (Converted Van), LTV (Light Transit Vehicle) and Bus "C" (Light Transit Bus). Sample specifications for this system follow.

This system shall be composed of the following elements. At each wheelchair position (WCP) wheelchair wheel locks shall be installed to secure the rear wheels and a two point belt-track attachment system installed to secure the front of the wheelchair. The components of each element shall be as follows:

- a. **Wheelchair Locks.** At each wheelchair position, a set of wheelchair locks shall be provided which will securely hold both rear wheels of the wheelchair in the wheelchair position while the vehicle is in motion. The wheelchair locks shall be capable of easily adjusting laterally without the use of tools to hold a wheelchair with a width from outside to outside of wheels and hand-rims of 25 inches and a wheelchair with a width from inside to inside of wheels of 16.75 inches.
- b. **Belt-track System.** This part of the securement system shall be similar to the front portion of an Aeroquip Corporation Wheelchair Securement System (or

an approved equal). However, a two point attachment system to secure the front of the wheelchair shall be used composed of one piece of track and two separate belts. The belts shall include all necessary buckles (both buckles shall be ratchet, or tensioning, buckles), hardware, fittings and other parts to make it a complete system. One piece of track (Aeroquip Series A or E, or equal) of sufficient length for proper attachment and positioning of the belts shall be placed perpendicular to the direction in which the wheelchair position (WCP) faces. The minimum length of track for one WCP shall be 36 inches and for two WCPs placed side-by-side shall be 62 inches. However, in every case the track shall project a minimum of 4" beyond the edge of the WCP. The track shall be located immediately to the front of the front wheels of the wheelchair when the rear wheels are locked into position (the distance of the centerline of the track from the inside surface of the wheelchair lock shall be minimum of 32 inches).

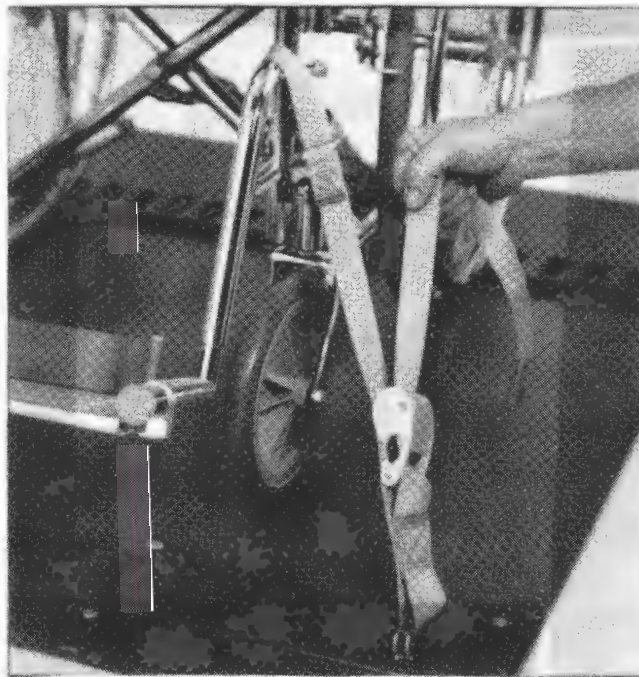

ILLUSTRATION 60 - AEROQUIP WHEELCHAIR SECUREMENT SYSTEM-BELTS

Source: Aeroquip Corporation

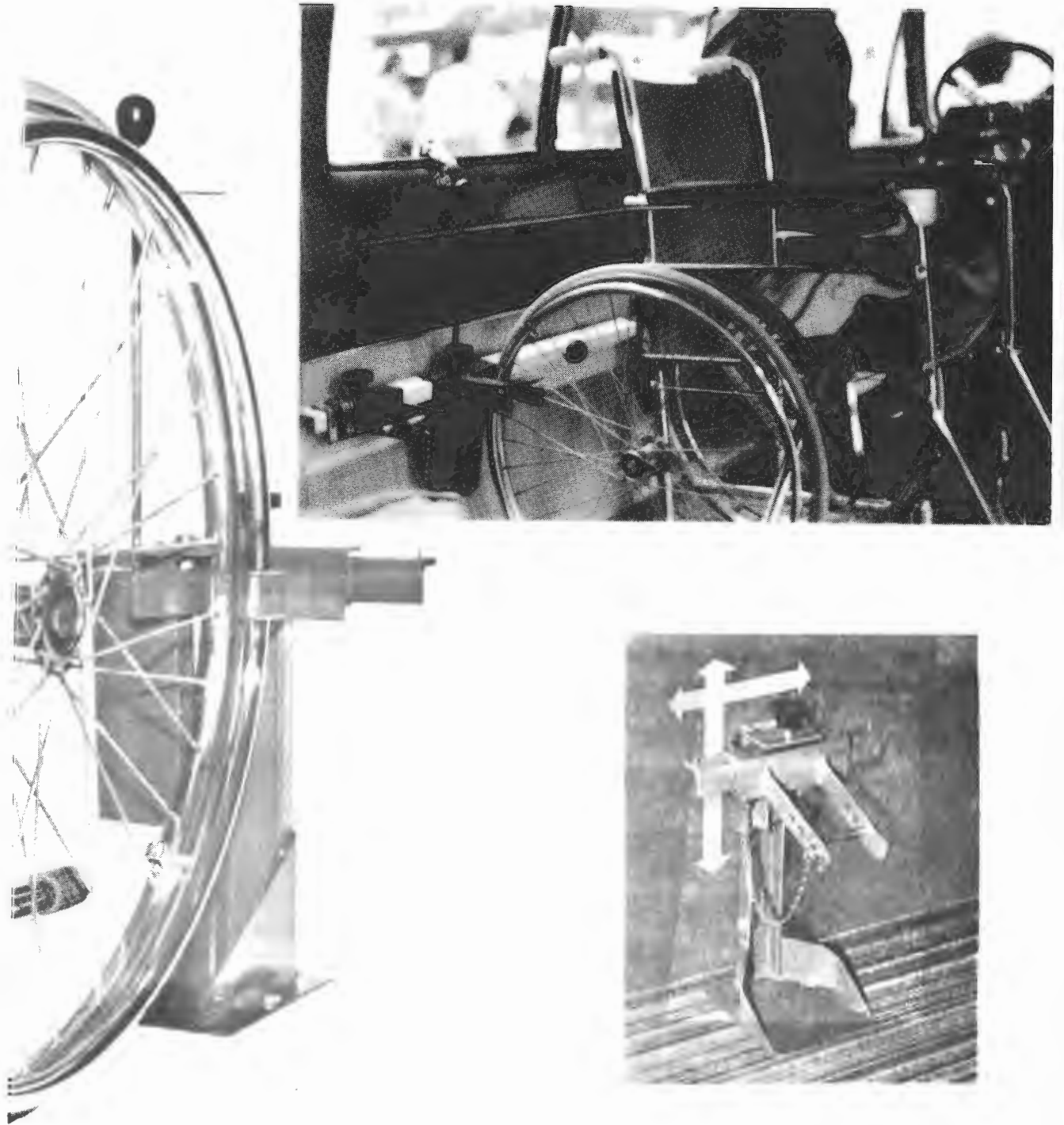

ILLUSTRATION 61 - COLLINS WHEELCHAIR SECUREMENT SYSTEM- LOCKS

Source: Collins Industries, Inc.

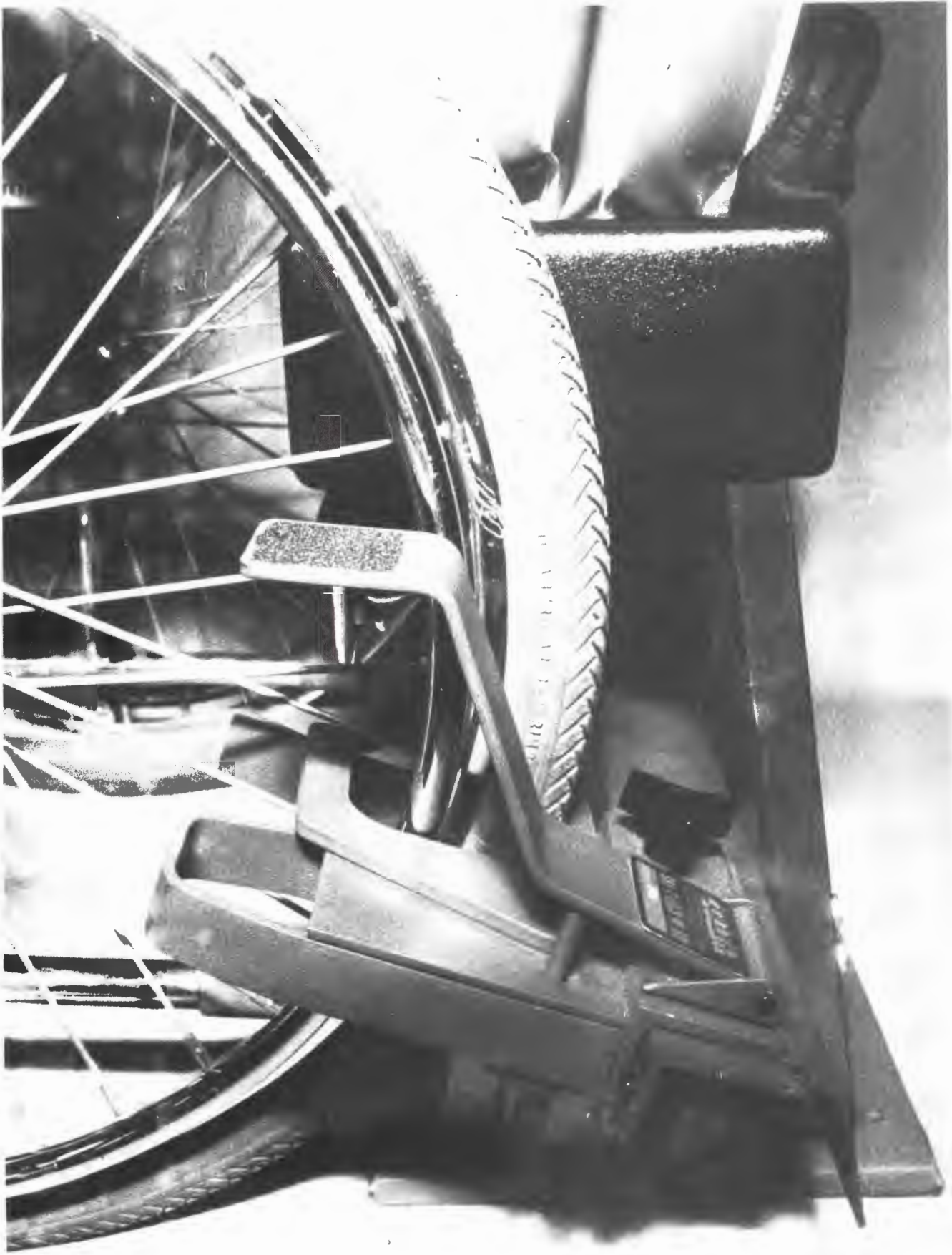

ILLUSTRATION 62 - COLLINS WHEELCHAIR
SECUREMENT SYSTEM-LOCKS

Source: Collins Industries, Inc.

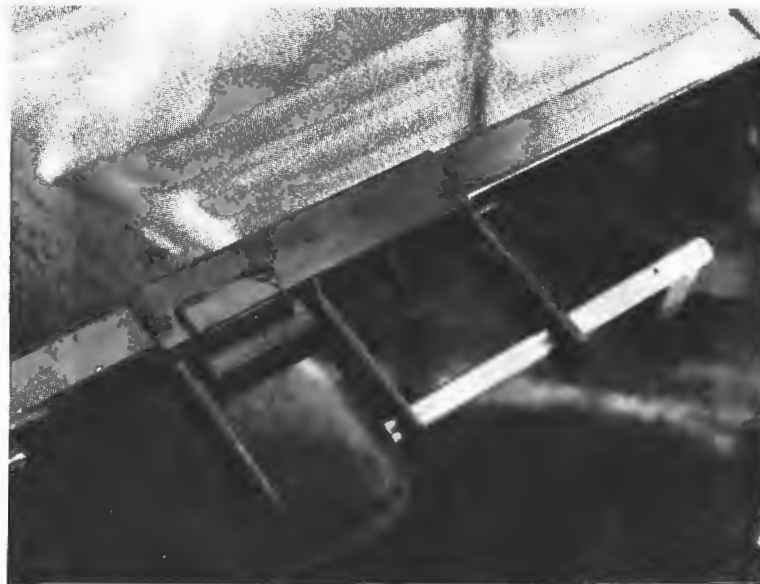

ILLUSTRATION 63 - BUD INDUSTRIES WHEELCHAIR SECUREMENT SYSTEM-LOCKS

Source: Piqua Taxi Cab Company

**IV-G. RESTRAINING DEVICES
FOR
WHEELCHAIR OCCUPANTS**

G. RESTRAINING DEVICES FOR WHEELCHAIR OCCUPANTS:

These devices are intended to secure a wheelchair passenger to the wheelchair and, in turn, to the vehicle itself. The ODOT procurement specifications for this item follow:

WHEELCHAIR OCCUPANT RESTRAINT SYSTEM: A restraint system shall be provided for the occupant of the wheelchair at each wheelchair position. The wheelchair occupant restraint system shall be a seat belt assembly permanently attached to the floor or side of the vehicle and equipped with a retractor or other device which keeps the belt webbing or strap off the floor when the belt is not in use.

Illustrations of several types of wheelchair occupant restraint systems are shown on the following pages.



ILLUSTRATION 64 - VELCRO SAFETY BELT

Source: Everest and Jennings

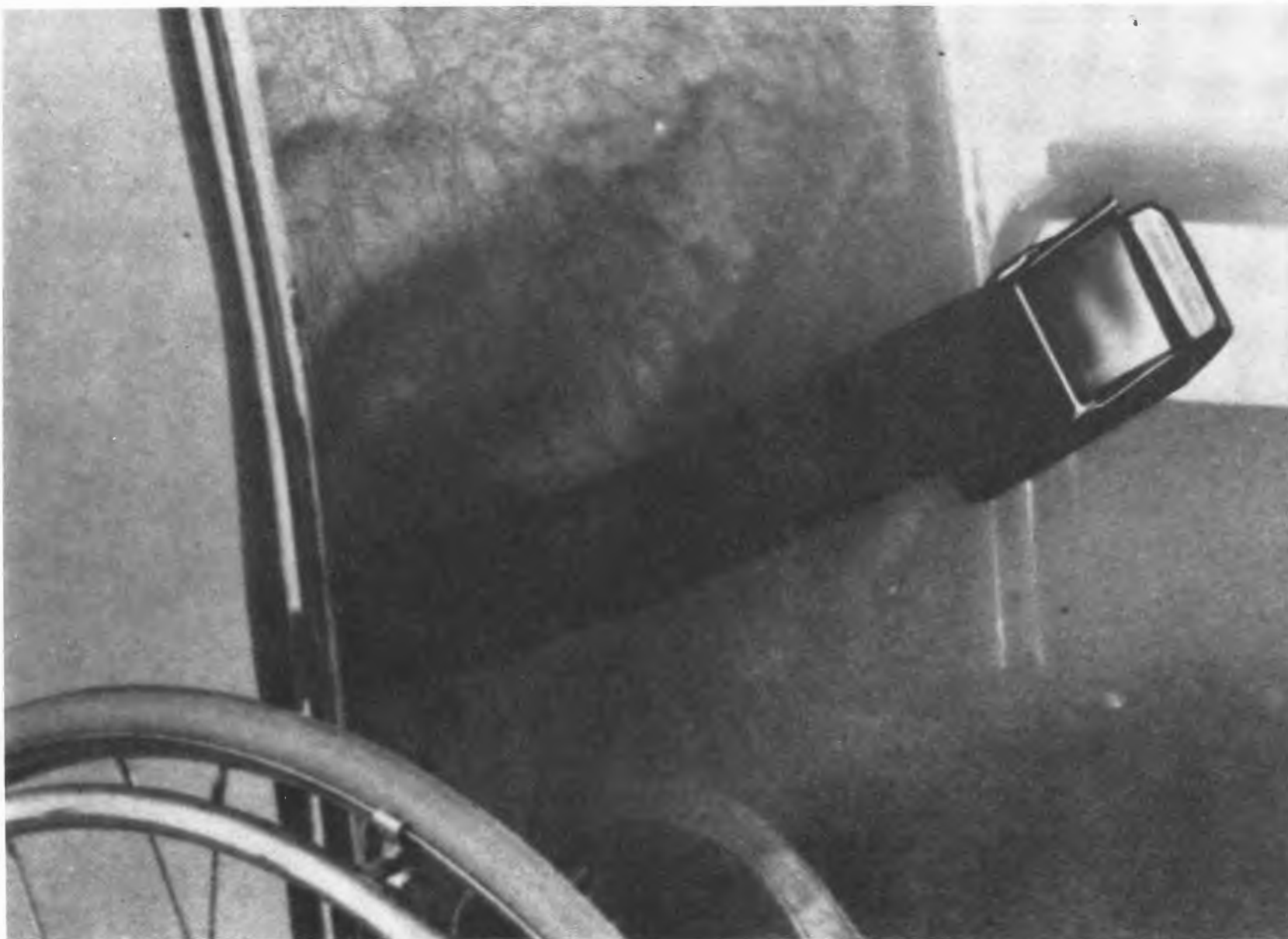

IV-35

ILLUSTRATION 65 - AUTO TYPE SEAT BELT

Source: Everest and Jennings

IV-H. JUMP SEATS

H. JUMP SEATS:

Jump seats are folding seats, located at wheelchair positions (WCP), which can be folded up to reveal wheelchair securement devices for use when a wheelchair is to occupy a WCP or can be folded down to permit seating ambulatory passengers when the WCP is not occupied by a wheelchair.

The ODOT procurement specifications for this item follow:

JUMP SEATS (OPTION): Jump seats are fold-down seats installed at the wheelchair positions in a vehicle equipped with a wheelchair lift system. Jump seats are intended to provide increased regular passenger seating capacity when persons in wheelchairs are not being transported. Jump seats may vary from the previously stated requirements for both the design and the dimensions of passenger seats.

Jump seats shall be in addition to the basic number of passenger seating positions required in the vehicle and shall not count toward the minimum passenger seating capacity required. The number of jump seats required, and their locations, shall be as specified.

Jump seats shall be attached to the interior wall or floor of the vehicle. Jump seats may be forward-facing or aisle-facing or a combination thereof. When folded up, jump seats shall not interfere with the use of wheelchair positions by passengers in wheelchairs. A seat belt shall be provided at each jump seat.

Each jump seat shall have a vinyl-covered cushion on the seat and seat back. Jump seats shall be of sturdy design and construction. Each jump seat shall accommodate one seated adult passenger with reasonable comfort.

Jump seats shall be designed to remain in a vertical position when folded-up and if a spring, or other type of mechanism, is used to return the seat from the horizontal to the vertical position, the return mechanism will not create a safety hazard for a passenger arising from the jump seat.

Illustrations of several types of jump seats are shown on the following pages.

FERNO-WASHINGTON JUMP SEAT

Model 555 (Universal Mounting)

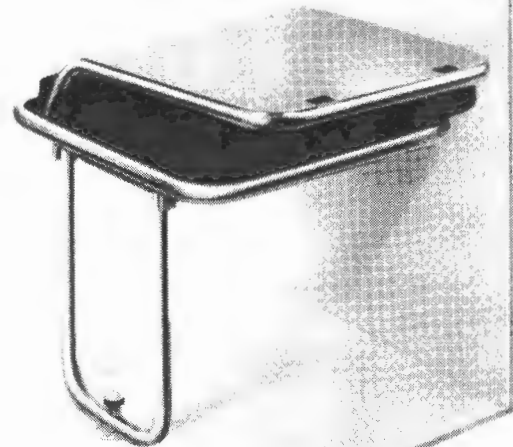
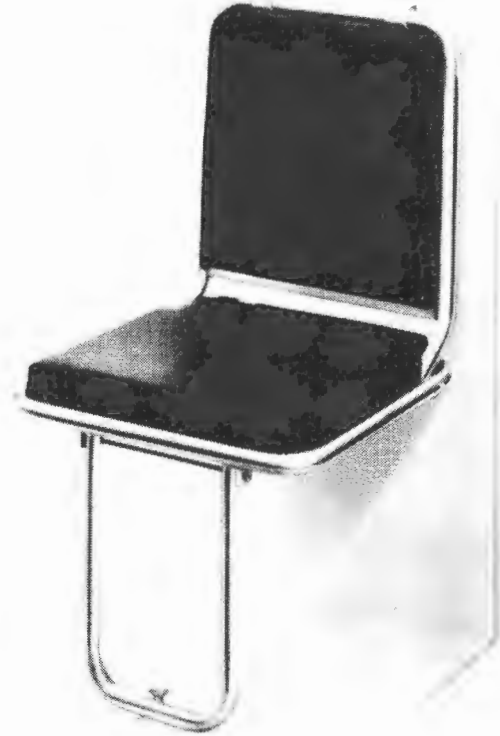
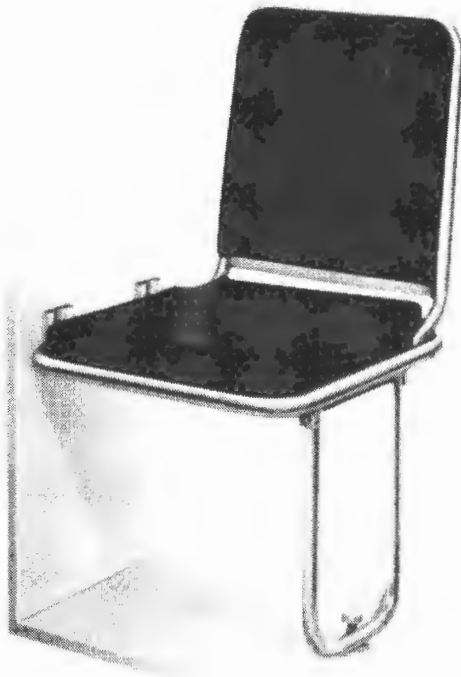

ILLUSTRATION 66 - FERNO-WASHINGTON JUMP SEAT

Source: Ferno-Washington, Inc.

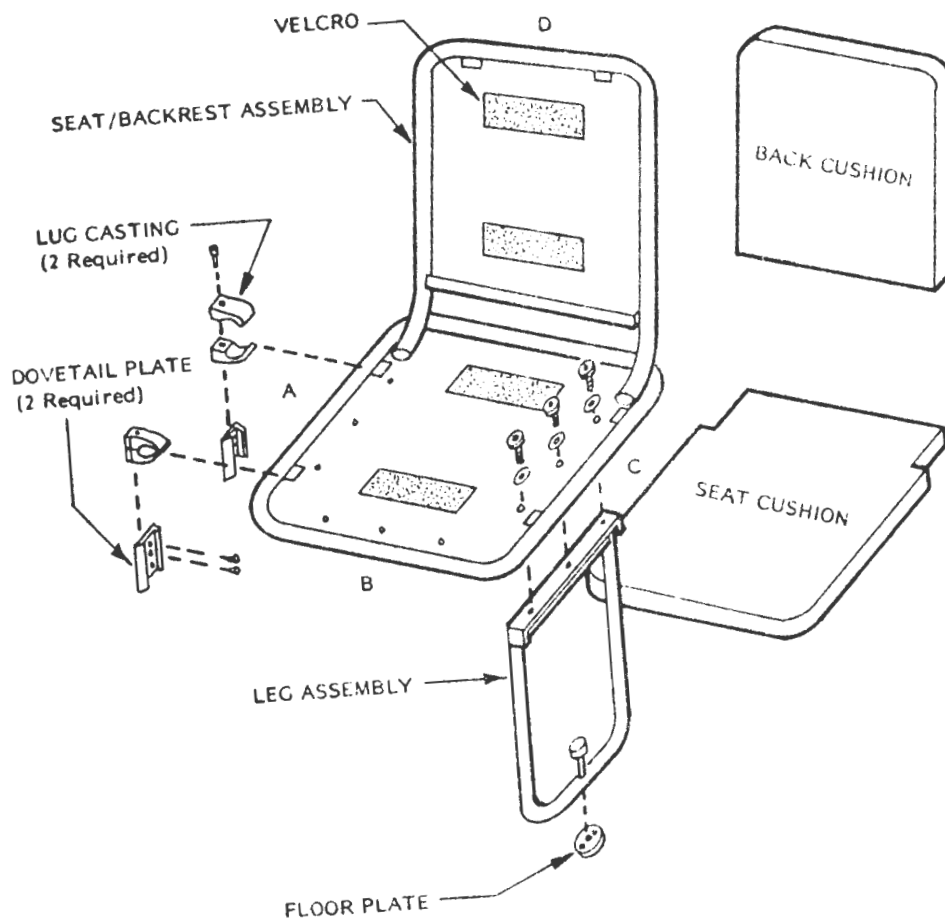
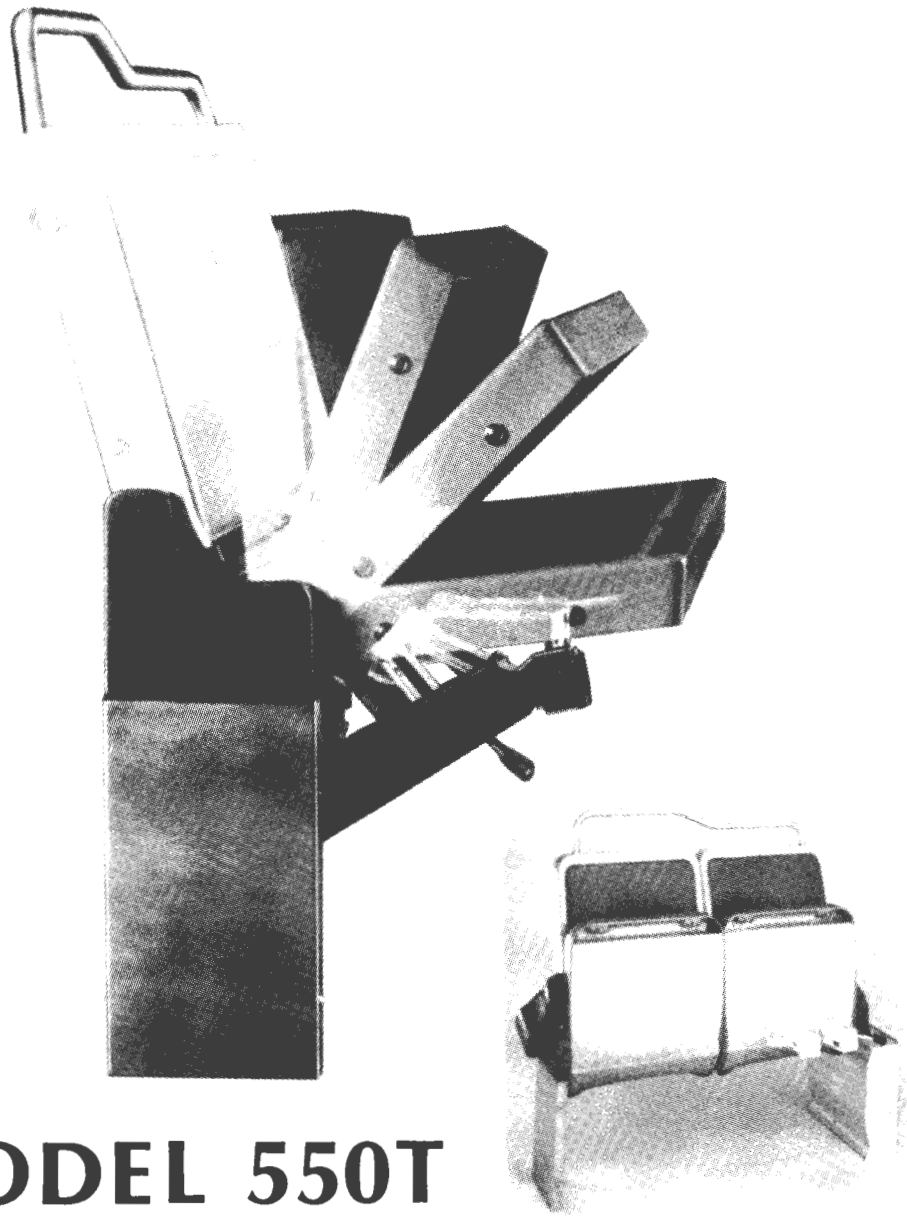

ILLUSTRATION 67 - FERNO-WASHINGTON JUMP SEAT DIAGRAM
Source: Ferno-Washington, Inc.



MODEL 550T

WHEELCHAIR RESTRAINT SEATING

ILLUSTRATION 68 - OTACO JUMP SEAT

Source: OTACO, Transportation Seating
Division

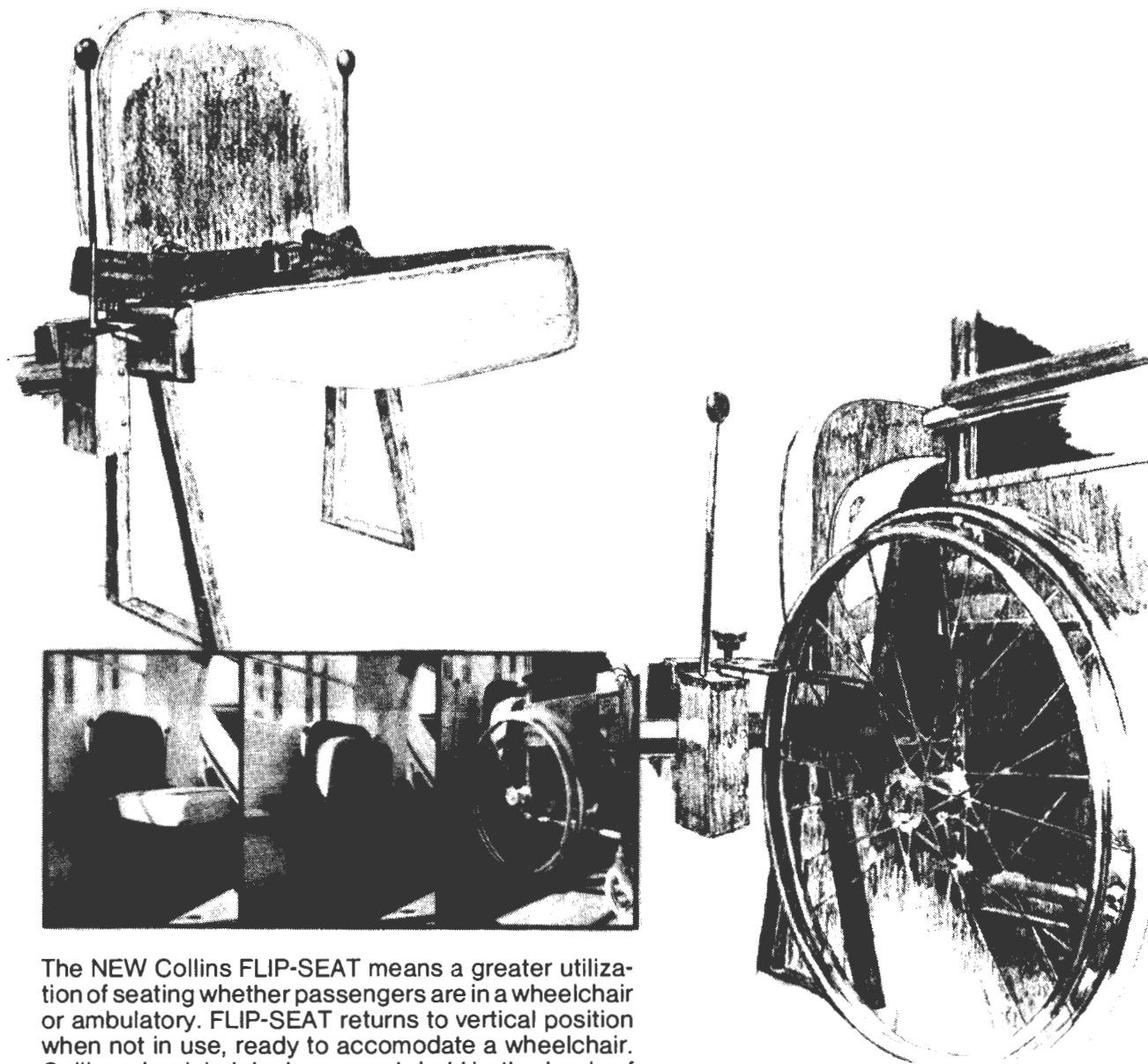

The NEW Collins FLIP-SEAT means a greater utilization of seating whether passengers are in a wheelchair or ambulatory. FLIP-SEAT returns to vertical position when not in use, ready to accommodate a wheelchair. Collins wheelchair locks securely hold both wheels of any wheelchair model during transport.

ILLUSTRATION 69 - COLLINS FLIP SEAT

Source: Collins Industries, Inc.



ILLUSTRATION 70 - COLLINS JUMP SEAT, INSTALLED

Source: Coach and Equipment Sales Corporation

IV-I. RUNNING BOARDS

I. RUNNING BOARDS:

The running, or side, boards are added to Van "A" (Standard Van) and Van "B" (Standard Van with Ramp) vehicles, on both sides, to ease entrance to, and exit from, the vehicle for both passengers and the driver. The ODOT procurement specifications for this item follow:

RUNNING BOARDS (OPTION): This item requires the installation of running boards on each side of the van as specified herein. The running board on the right (passengers') side of the van shall extend from the rear edge of the front wheelwell to at least the rear face of the van's built in step for the side door (a distance of approximately 74" to 85" according to the van make or model). The running board, or "side" board on the left (driver's) side of the van shall extend from the rear of the front wheelwell to at least the rear of the driver's door opening (a distance of approximately 24" to 35" according to the van make and model). Running boards shall be of rattle free one-piece construction. The boards shall have a transverse cross section composed of a vertical flange of 2" at the rear (next to the van body) extending above the horizontal surface, a horizontal surface (tread depth) with a minimum width of 10", and a vertical surface of 2" at the front (away from the van body) extending below the horizontal surface (the dimensions of the transverse cross section surfaces may vary by $\pm 1/4$ "). A front splash guard shall be provided for each running board. The running boards shall be made of aluminum material of 1/8" (minimum) thickness. Splash guards shall be made of aluminum material; if the material used is less than 1/8" thick, an additional bracket (see below) shall be required at the splash guard ends to ensure adequate structural support of the running board. The horizontal portion of the running board shall have a skid resistant tread surface (e.g., raised diamond pattern, shark's teeth pattern, etc.) or contain longitudinal non-skid strips.

Running boards shall be securely mounted to the side of the van by a combination of horizontal brackets (extending under the boards) and bolts in sufficient quantities to insure strength, stability and safety. However, a minimum of four brackets shall be used to attach the right board and a minimum of two brackets to attach the left board. The splash guards shall be securely mounted to the van and the running board.

Note: The intent of this specification is to obtain a running or "side" board of sufficient width to allow safe entrance and egress to the vans by physically impaired and/or elderly persons. Therefore, the 10" tread depth (or width), plus or minus 1/4", is to be strictly adhered to. If a running board of sufficient tread depth is not commercially available, the vendor should have boards fabricated from flat

aluminum stock which can be cut and bent to the specified dimensions.

The vendor shall submit a description of the type of running board and mounting procedures (all pertinent dimensions must be included) with his bid. Bids shall include the costs of the materials and installation.

Running boards may be fabricated by the vendor, or his supplier, or may be commercially manufactured. Illustrations of commercial running boards are shown on the following pages.

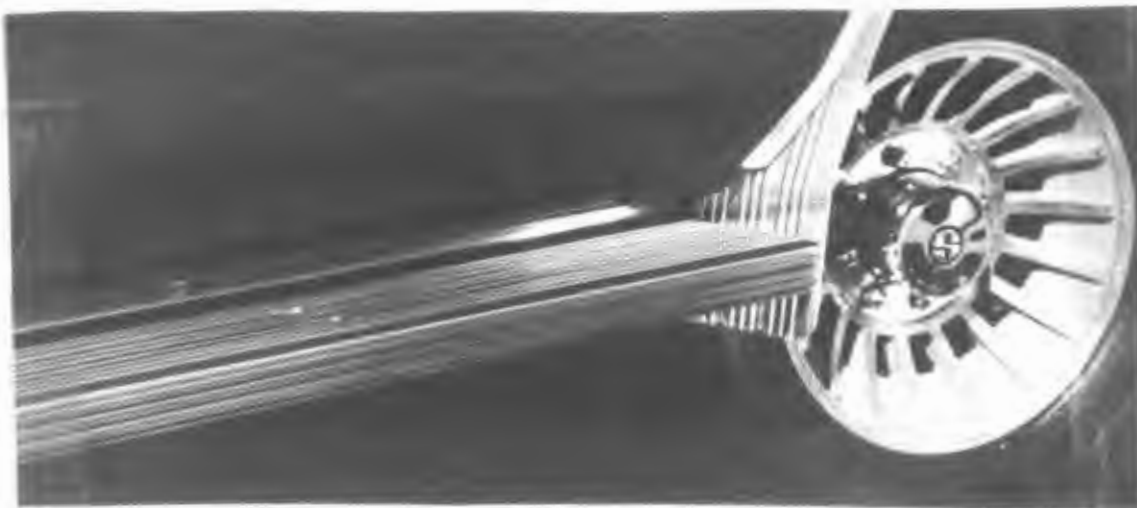

ILLUSTRATION 71 - E.Z. SIDER RUNNING BOARD

Source: Superior/Ideal Inc.

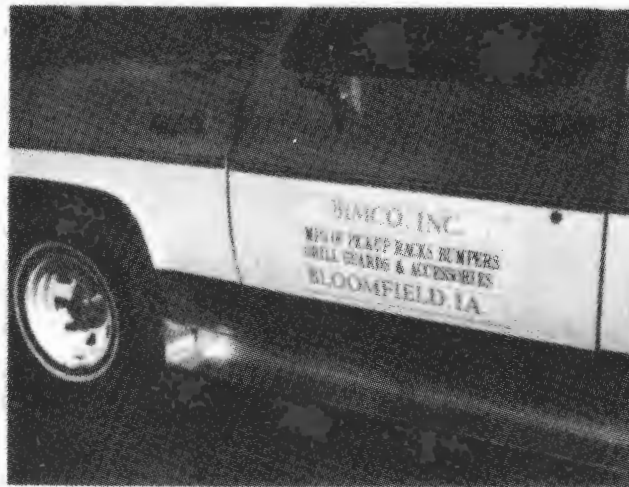

ILLUSTRATION 72- BIMCO RUNNING BOARDS

Source: BIMCO, Inc.



ILLUSTRATION 73 - INSTALLED RUNNING BOARD

Source: Elderly United of Springfield
and Clark County

IV-J. TWO-WAY FM RADIOS

J. TWO-WAY FM RADIOS:

For those agencies requiring two-way radio communications between their vehicles and their dispatcher, this option may be chosen (please note: these are two-way FM radios, not CB radios). The UMTA Section 16(b)(2) Program will provide the number of mobile radio units required, and fully justified, by the agency to operate its transportation system, subject to funding limitations. A radio, or radios, will be provided only under the following circumstances.

1. Agency has an existing radio system. The new radios will be required to be compatible with the existing radio equipment, and meet certain minimal standards as specified by ODOT.

The only ways a radio, or radios, can be procured individually (not part of a new system) are if the agency has an existing radio system, including a base station, antenna and arrangements for broadcasting the signal; or has firm arrangements to use another agency's dispatcher and sending/receiving equipment. A radio (or radios) can be obtained merely by completing the necessary portions of the application, if its (their) need is (are) justified.

2. Agency does not have an existing radio system. An agency can apply for a new radio system, if it does not have a system in operation or available, providing it can justify, in detail, the need for two-way communication between the dispatcher and the driver. To request a complete new radio system, the agency must perform the following actions:

- a. Prepare a detailed request explaining why a two-way FM radio system is required. The request must contain a complete justification for the system and include certain technical information such as the proposed location of the base station (dispatcher); the location of the base station antenna; the location of the repeater station (for sending the signal to the mobile units); the number of mobile units required; and the area coverage (county-wide, city-wide, etc.) desired.

This request must be in addition to the basic application and will not be considered without the written justification. Also, the request must be submitted according to the deadlines for the basic application.

- b. Receive approval from the local MPO, if appropriate.
- c. Receive approval from ODOT. Please note, the basic vehicle may be approved by ODOT and the special request for a radio system refused. That is, a combined request for a vehicle and a complete radio system will be considered as separate proposals.

The establishment of a new radio system is relatively expensive, requiring \$5,000 to \$10,000 depending on the number of mobile units required and whether or not a repeater is available for use. Also, if a repeater is used, which is the usual arrangement, a monthly rental fee (\$25 to \$100, according to the number of units) will be required -- paid out of the agency's operating budget.

The ODOT procurement specifications are too voluminous to be repeated "in toto" herein. However, the first paragraph of those specifications is repeated below for informational purposes.

SPECIFICATIONS FOR
TWO-WAY RADIO

GENERAL: A two-way radio shall consist of a complete two-way FM mobile radio voice communications system installed in a vehicle and ready for operation. The overall design of the system shall meet or exceed all standards of the Electronics Industries Association (EIA). In addition, the radio system shall meet or exceed all applicable Federal Communications Commission (FCC) requirements. The two-way radio system shall include a radio set unit, control unit, microphone or handset, speaker unit, antenna, interconnecting cable, wiring, mounting hardware and such other items as shall be required for a complete two-way FM mobile radio installation. The two-way radio system shall be completely solid state and of modular construction to facilitate maintenance. All parts shall be new.

The radio system shall operate directly off the vehicle battery with no internal power supply. The two-way radio system shall operate as specified through a temperature range of minus thirty (-30) degrees Celsius to sixty (60) degrees Celsius. The two-way radio system shall be designed to operate on twelve (12) volts d.c. with temporary peak voltages as high as sixteen (16) volts. All wiring shall be properly insulated and, as necessary, shall be held in place with clamps. Except for the microphone or handset cord, there shall be no exposed or loose wiring in the driver or passenger compartment of the vehicle.

Various companies provide satisfactory radios that meet the ODOT specifications. Some illustrations of typical two-way FM mobile radio units are shown on the following pages. None of these may be the make or model provided; the ODOT bidding procedures will determine the successful vendor.

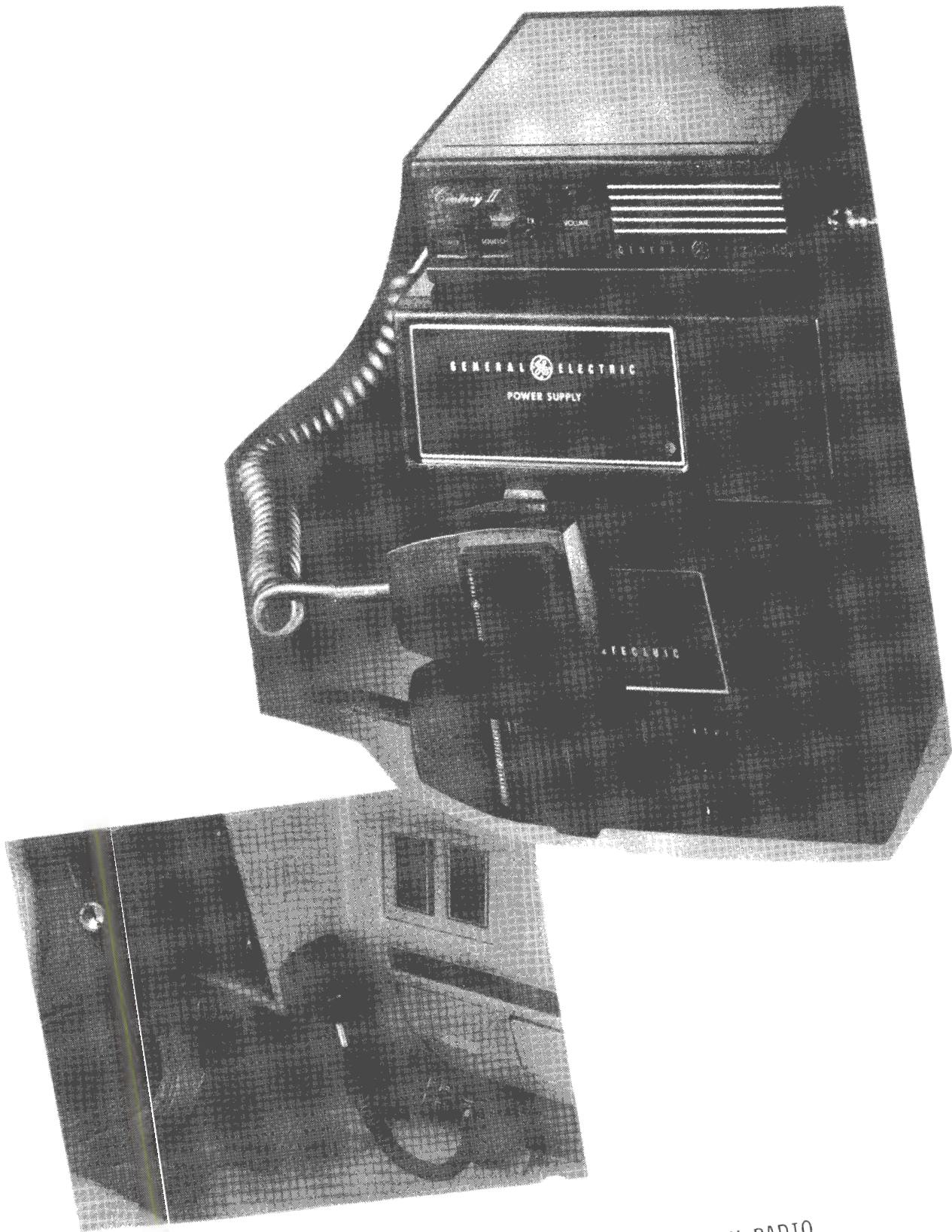

ILLUSTRATION 74 - GENERAL ELECTRIC TWO-WAY RADIO

Source: General Electric Co.



ILLUSTRATION 75 - MOTOROLA TWO-WAY RADIO

Source: Motorola Corporation



ILLUSTRATION 76 - RCA TWO-WAY RADIO

Source: RCA Mobile Communications Systems



ILLUSTRATION 77 - REGENCY TWO-WAY RADIO

Source: Regency Electronics

IV-K. HANDICAPPED DRIVER ASSIST DEVICES

K. HANDICAPPED DRIVER ASSIST DEVICES:

These are devices added to the vehicle for use by a driver with physically impaired legs. The devices will enable a handicapped driver to control the following functions by use of his hands:

1. Brake
2. Throttle
3. Light Dimmer Switch

The ODOT procurement specifications for this item follow:

SPECIFICATIONS FOR
DRIVER HAND CONTROLS

The driver hand controls shall be provided complete and installed on the vehicle. The driver hand controls shall provide for hand operation of both the accelerator and brake pedals by means of a lever located next to the steering wheel. The driver hand controls shall also include a hand-operated headlight dimmer switch located next to the steering wheel.

The brake and accelerator shall be controlled by a single lever with a vinyl hand grip. The control lever shall be the type which is rotated to accelerate (i.e., feed gas) and pressed floorward to apply brakes. An adjustable leverage bar shall be provided just next to the control lever to provide additional hand leverage while operating the control lever. The hand-operated dimmer switch shall be designed to be operated by the thumb.

Conventional or normal operation of the accelerator pedal, brake pedal and foot-operated dimmer switch shall not be affected or interfered with by the installation of driver hand controls. The driver hand controls shall be securely attached to the pedals and steering column but shall be removable.

The controls shall be installed for left hand use. All equipment shall be of rugged construction. All parts shall be new.

The manufacturer shall provide a full one year warranty for the driver hand controls. The manufacturer shall provide a replacement part promptly and without charge for any part of the driver hand controls which fails or proves defective within one year after final delivery of the vehicle equipped with hand controls. The successful vendor shall provide the manufacturer's warranty statement.

Illustrations of driver hand controls are shown on the following pages.

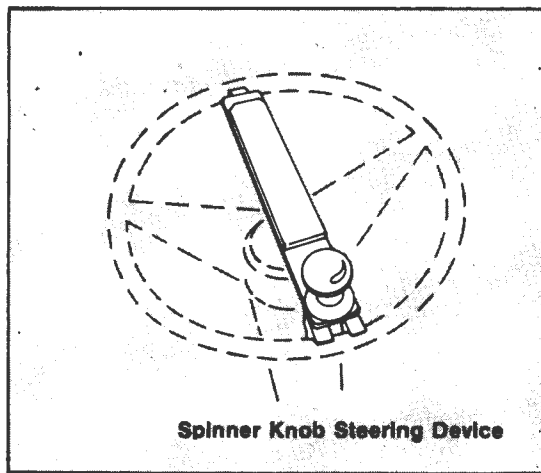
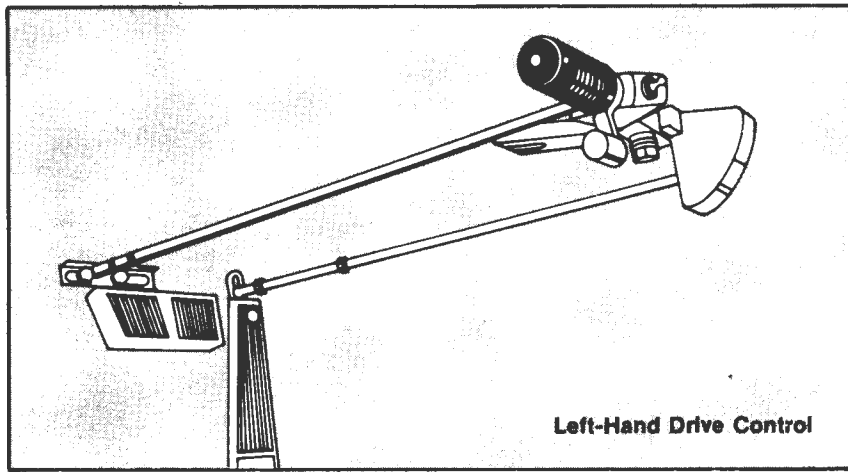
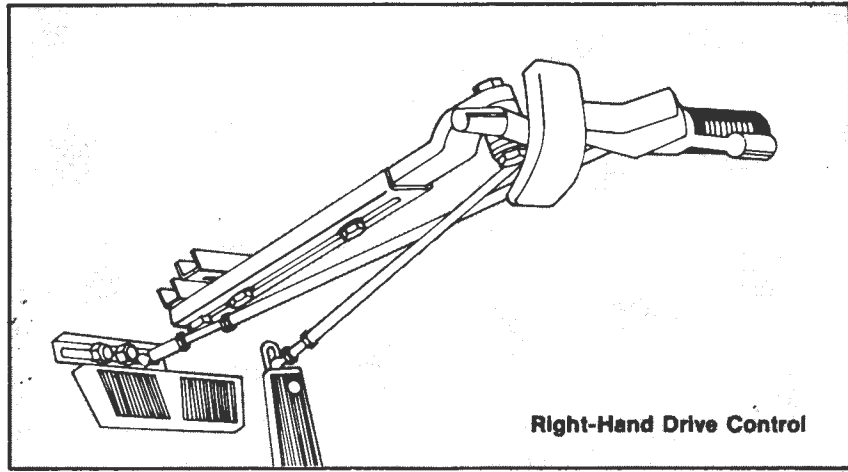

ILLUSTRATION 78 - DRIVING AIDS
Source: Wells-Engberg Company, Inc.



ILLUSTRATION 79 - SLIM LINE CONTROL

Source: Gresham Driving Aids, Inc.

IV-L. AIR CONDITIONING

L. AIR CONDITIONING:

The air conditioning option is available for all vehicles. Van "A" and Van "B" vehicles require factory installed front and rear units; Van "C" vehicles require both front and rear units, however, only the front must be factory-installed; LTV's and Buses require the air conditioning system to be adequately sized to properly cool the vehicle throughout the driver and passenger compartments but do not specify the number or source of the A/C units.

The ODOT procurement specifications are as follows:

For Vans "A" and "B":

AIR CONDITIONER (OPTION): An air conditioner system shall be provided on certain individual vehicles as an option. On vehicles to be provided with this option, both a front air conditioner unit and an auxiliary air conditioner unit in the passenger compartment shall be furnished. All air conditioning equipment shall be factory-installed by the van manufacturer. Tinted glass shall be provided in the windshield and all windows as part of the air conditioning package.

For Van "C":

AIR CONDITIONER (OPTION): An air conditioner system shall be provided on certain individual vehicles as an option. The air conditioner system shall consist of both a front air conditioner unit factory-installed by the chassis manufacturer and a rear air conditioner unit. The rear air conditioner unit shall have a cooling capacity of at least 12,000 BTU/hour. Cooling shall be provided throughout the driver and passenger compartments.

For LTV's and Buses "A", "B", and "C":

AIR CONDITIONER (OPTION): Air conditioning equipment shall be adequately sized for proper cooling during stop-and-go operation of the vehicle. Air conditioning equipment shall be capable of providing at least minimal operation at vehicle idling speeds. The air conditioning system shall be thermostatically controlled and shall have condenser fans capable of operating at vehicle idling speeds. The evaporator fans shall be of adequate size. The air conditioning system shall be capable of maintaining a temperature of 75 degrees Fahrenheit or less throughout the driver and passenger compartments of the vehicle with an outside ambient temperature of 95 degrees Fahrenheit and 50 percent relative humidity under normal operating conditions. The air conditioning equipment shall provide for cool air distribution for the full length of the passenger compartment.

The make of the air conditioning may vary according to the make of the vehicle and/or vendor. Vans "A" and "B", and the front unit of Van "C" will be the standard unit provided by the van manufacturer. The rear unit on a Van "C" and the entire air conditioning systems for LTV's and Buses "A", "B", and "C" may be manufactured by any of several companies. However, all will be installed by the van converter or the vehicle body manufacturer.

Since the variety of air conditioners is numerous, the agency (or ODOT) has no input into the selection of the make of the air conditioner. However, ODOT ensures that all air conditioner systems meet the procurement specifications before purchase orders are issued.

An illustration of a typical rear unit air conditioner for Van "C"s and LTVs is shown on the following page. The rear air conditioner unit for buses is typically placed under the rear seat.

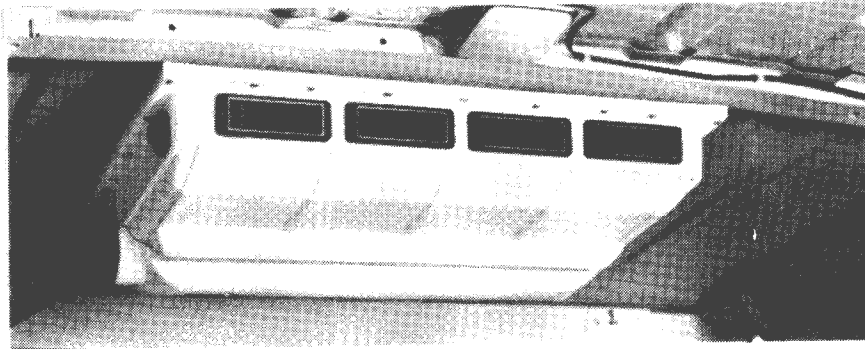

ILLUSTRATION 80 - TYPICAL REAR UNIT AIR CONDITIONER
FOR VAN "C"'s AND LTV's

Source: ARA Manufacturing Co.

ILLUSTRATION 81 - TYPICAL AIR CONDITIONERS FOR
LTVs AND BUSES

Source: Trans/ Air Manufacturing

(See pages IV-59 and IV-60)



The TRANS/AIR Model MC-3 HC (68,000 BTU) provides ample capacity to properly air condition the bus for shuttle and transit applications.



The longitudinal evaporator(s) distribute the conditioned air throughout the bus.



A separate driver's module with adjustable louvers keeps your driver cool and comfortable.

For further information contact: TRANS/AIR MFG., 480 E. Locust St., Dallastown, PA 17313



The TRANS/AIR RC Series has the capacity for air conditioning the smaller buses in transit applications. This unit is the RC45 (45,000 BTU/hr cooling) which has a skirt mounted condenser and bus engine driven compressor for simple and efficient operation.



The rear mount package installs readily and has both cooling and heating in one compact housing. All refrigerant, hot water, and drain lines are shielded with covers provided, making a neat appearance. All controls are located within easy reach of the driver.

For further information contact: TRANS/AIR MFG. CO., 480 E. Locust St., Dallastown, PA 17313

IV-M. RADIAL TIRES

M. RADIAL TIRES:

For this option, the proper sized tire with the correct load rating for the vehicle shall be provided for all tires in lieu of the standard tires that would normally be furnished. The ODOT procurement specifications are as follows:

RADIAL TIRES (OPTION): On vehicles on which radial tires are to be provided, all tires shall meet the previously stated requirements for tires and, in addition, all tires shall be radial tires. The bid price submitted for this option should be the additional cost of providing radial tires on the vehicle instead of the tires which would otherwise have been provided.

Many tire manufacturers provide radial tires for vans and buses (truck chassis). The tire provided for a particular vehicle may be of a make normally provided by the vehicle (van or bus chassis) manufacturer or may be of an entirely different make. The reasons for this is that sometimes the vehicle vendor will make arrangements with a local tire dealer to exchange the standard tires for the proper radial tires. However, all tires will carry an industry (tire) wide type of warranty.

No illustrations are shown herein.

IV-N. WHEELCHAIR ACCESSIBILITY SYMBOL

N. WHEELCHAIR ACCESSIBILITY SYMBOL:

If this option is chosen, two "International Accessibility Symbols" will be provided on the vehicle. The ODOT procurement specifications for this item follow:

INTERNATIONAL ACCESSIBILITY SYMBOL (OPTION): The international accessibility symbol is a symbol placed on a vehicle equipped with a wheelchair lift system to indicate that the vehicle is accessible to persons in wheelchairs. The international accessibility symbol shall be affixed to the outside of the vehicle body at the following two locations:

- a. at the lift, either on one of the doors to the lift entryway or immediately next to one of those doors, and
- b. on the rear of the bus.

The international accessibility symbol shall be that symbol depicted on sign D9-6 in the "Manual of Uniform Traffic Control Devices" published by the Federal Highway Administration of the U.S. Department of Transportation. The symbol provided shall be between 5 inches and 12 inches in overall height.

An example of an "International Accessibility Symbol" is shown on the following page.



ILLUSTRATION 82- WHEELCHAIR ACCESSIBILITY SYMBOL

IV-O. CUSTOM SEATS

0. CUSTOM SEATS:

Custom seats are to be provided in lieu of regular passenger seats. They are to be of a deluxe type with an improved suspension system. They will probably not be provided with seat belts. Armrests, except on aisle facing seats as per the specifications, may or may not be provided. For a bus with many seats, this is an expensive option. The ODOT procurement specifications for this item follow:

CUSTOM SEATS (OPTION): On buses in which custom seats are to be provided, all passenger seats (excluding jump seats at wheelchair positions) shall be custom seats.

Custom seats shall be deluxe passenger seats which meet all requirements contained in these specifications for passenger seating as well as the following additional requirements.

- (1) Individually molded foam cushions of the contoured bucket type shall be provided for each seated passenger in order to increase passenger comfort and provide designation of individual seating areas.
- (2) Passenger seats shall be of arched serpentine spring construction for improved passenger comfort and support.
- (3) Protective high-impact thermoplastic closure panel covers shall be provided on the side of bottom seat cushions facing the passenger aisleway.

All seat back grab rails on custom seats shall be of the plastic-covered energy-absorbing type.

On custom seats, passenger seat belts may or may not be provided, at vendor's option. Also, at vendor's option, armrests may or may not be provided on forward facing custom seats. However, armrests must be provided on certain aisle facing seats as per specifications.

Illustrations of regular passenger seats and, for comparison purposes, custom seats are shown on the following pages.

bPT20K

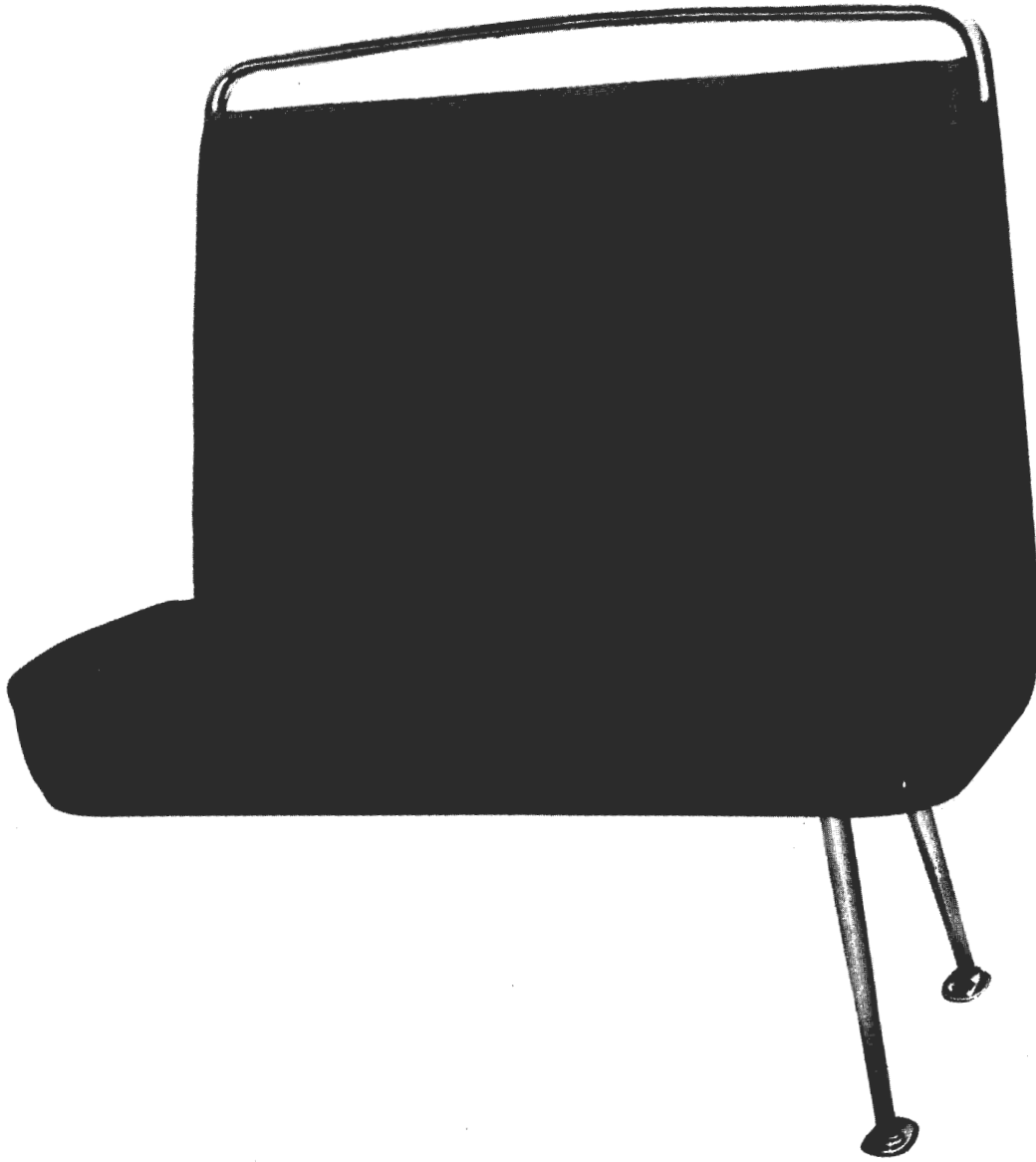

ILLUSTRATION 83 - TYPICAL STANDARD PASSENGER SEAT
(REGULAR SEAT)

Source: American Seating Co.



ILLUSTRATION 84 - STANDARD FIBERGLASS SHELL
PASSENGER SEAT
(REGULAR SEATS)

Source: OTACO, Transportation Seating Division

BLUE BIRD SEATS



Blue Bird economy seat has cut-a-way corners for grab handle. Shown with welt.

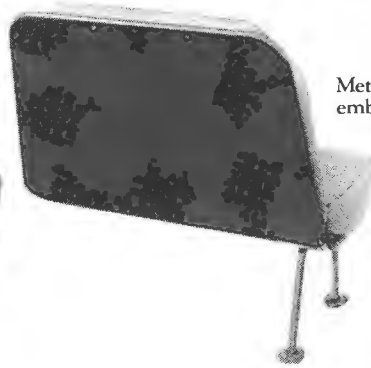

Metal seat back painted and embossed.



Two fasteners secure each seat leg to floor.



Blue Bird city-type seat with handrail.



Blue Bird Adult Passenger Seat

ILLUSTRATION 85 - TYPICAL STANDARD PASSENGER SEATS (REGULAR SEATS)

Source: Blue Bird Company



ILLUSTRATION 86 - TYPICAL CUSTOM SEATS
Source: American Seating Co.

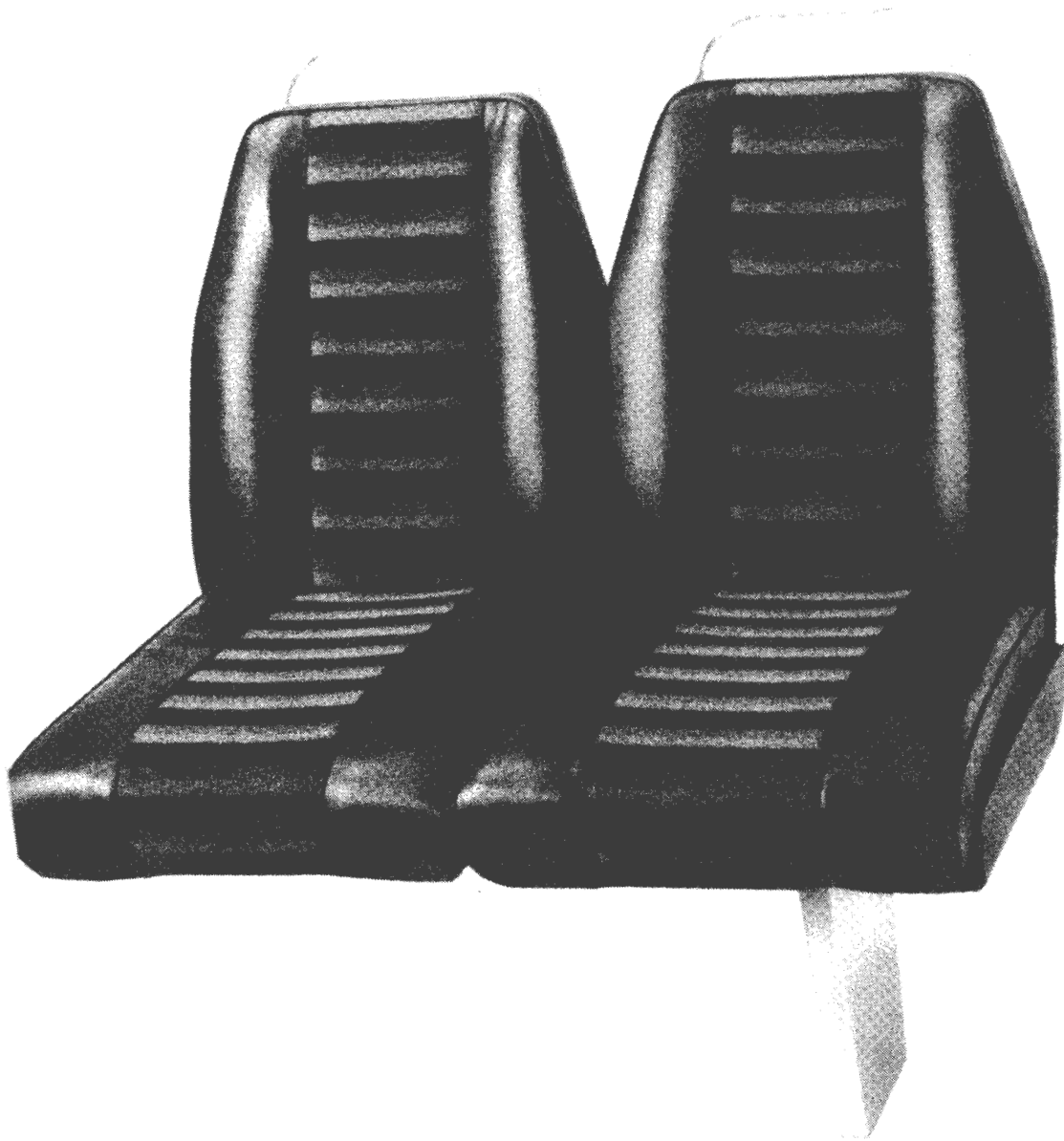

ILLUSTRATION 87 - TYPICAL CUSTOM SEATS
Source: OTACO Transportation Seating

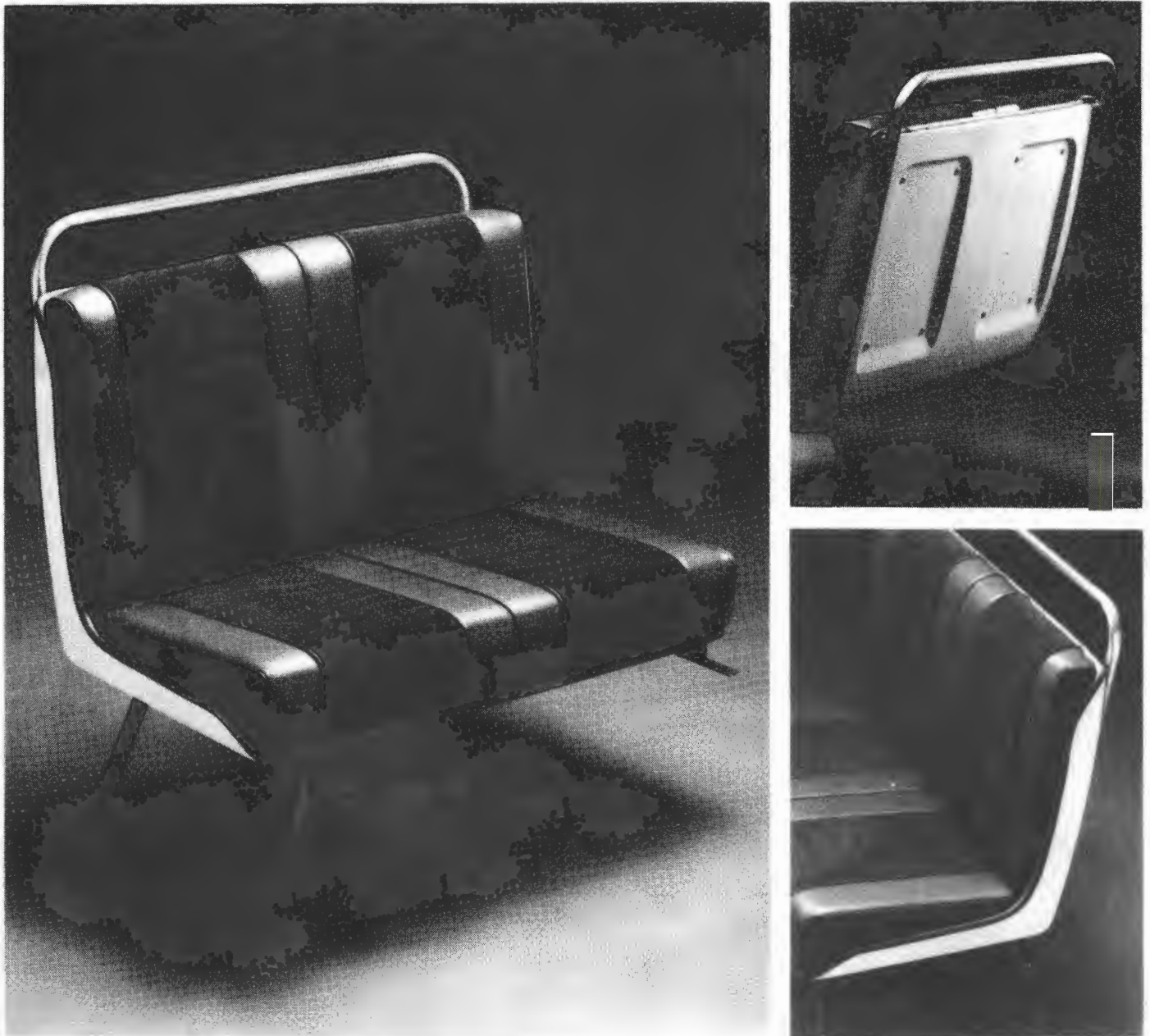

ILLUSTRATION 88 - TYPICAL CUSTOM SEATS

Source: The C.E. White Co.

**V. ESTIMATED COSTS OF VEHICLES
AND
EQUIPMENT**

TABLE OF CONTENTS - SECTION V

	<u>Page</u>
V. <u>ESTIMATED COSTS OF VEHICLES AND EQUIPMENT</u>	V-1
Cost Estimation Examples	V-2
A. Van Series	V-5
1. Standard Vans (Van "A")	V-5
2. Vans with Ramp (Van "B")	V-5
3. Converted Vans (Van "C")	V-6
B. Light Transit Vehicles (LTV)	V-8
C. Bus Series	V-10
1. Modified School Bus (Bus "A")	V-10
2. Light Bus (Bus "B")	V-12
3. Light Transit Bus (Bus "C")	V-14

V. Estimated Costs of Vehicles and Equipment:

The following pages contain the estimated costs for each vehicle offered in the UMTA Section 16(b)(2) F.Y. 1983 Program plus estimated costs for optional ancillary equipment that may be added to the vehicle.

The tables will list the costs by the vehicle designation number; and a description of the vehicle, or the ancillary equipment, will not be repeated herein. Complete descriptions of vehicles and ancillary equipment are contained in Sections III and IV of the vehicle catalog, published separately. As explained in Section III, the following designation system is used throughout the text:

VA - Indicates the vehicle is a standard van

VB - Indicates the vehicle is a standard van with a wheelchair ramp

VC - Indicates the vehicle is a converted van

LTV- Indicates the vehicle is a light transit vehicle

BA - Indicates the vehicle is a modified school bus

BB - Indicates the vehicle is a light bus

BC - Indicates the vehicle is a light transit bus

The estimated costs for the basic vehicle includes the costs of all ancillary equipment which have been added to the vehicle as "standard equipment" and which take no further action by the agency to be included on the vehicle. Also, since this equipment has been deemed necessary and/or desirable by ODOT for inclusion on the vehicle, it (the equipment) cannot be deleted.

The total cost of an equipped vehicle to the agency is a sum of the basic vehicle cost (includes all standard included equipment for a particular vehicle designation) plus the cost of all chosen (by the agency) optional equipment.

Examples of how to estimate the cost of a vehicle with desired options are given on the following pages.

April 1983

COST ESTIMATION EXAMPLES

EXAMPLE 1:

Vehicle Desired: A Standard Van with a Ramp in the Rear.

Vehicle Designation: VB-10-1

Options Desired: (a) Air Conditioning
(b) Running Boards
(c) Accessibility Symbol
(d) Two-way FM Radio

Computation of Total Cost of Vehicle and Equipment:

Standard Vehicle	=	\$11,050.00
Wheelchair Ramp	=	525.00
Wheelchair Position	=	250.00
Air Conditioning	=	1,150.00
Running Boards	=	250.00
Accessibility Symbols	=	25.00
Two-way FM Radio	=	1,300.00
Total (Veh. & Equipment)	=	<u>\$14,550.00</u>
5% Contingency	=	+ 727.50
Grand Total	=	<u>\$15,277.50</u>

EXAMPLE 2:

Vehicle Desired: A converted van with a side mounted wheelchair lift, six seated passengers and three wheelchair positions; with forward facing seats.

Vehicle Designation: VCS-6-3 (Option 1)

Options Desired: (a) Jump Seats
(b) Air Conditioning
(c) Radial Tires
(d) Accessibility Symbols

Computation of Total Cost of Vehicle and Equipment:

Standard Vehicle	=	\$14,950.00
Wheelchair Lift	=	1,900.00
Wheelchair Positions (3)	=	525.00
Jump Seats	=	700.00
Air Conditioning	=	1,150.00
Radial Tires	=	375.00
Accessibility Symbols	=	25.00
Total (Veh. & Equipment)	=	<u>\$19,625.00</u>
5% Contingency	=	+ 981.25
Grand Total	=	<u>\$20,606.25</u>

EXAMPLE 3:

Vehicle Desired: A light bus, seating twenty-one passengers in extra comfort (no wheelchair lift).

Vehicle Designation: BB-21-0

Options Desired: (a) Air Conditioning
(b) Radial Tires
(c) Custom Seats
(d) Two-way FM Radio

Computation of Total Cost of Vehicle and Equipment:

Standard Vehicle	=	\$24,750.00
Air Conditioning	=	3,350.00
Radial Tires	=	475.00
Custom Seats	=	4,200.00
Two-way FM Radio	=	1,300.00
Total (Veh. & Equipment)	=	<u>\$34,075.00</u>
5% Contingency	=	+ 1,703.75
Grand Total	=	<u>\$35,778.75</u>

A. VAN SERIES

1. STANDARD VANS (VA's)
and
2. STANDARD VANS WITH RAMP (VB's)

Vehicles Available

Vehicle Designation	Estimated Costs(4)			
	Standard Vehicle(1)	Wheelchair Ramp	WCP(2)	Total of Basic Vehicle(3)
VA-11-0	\$10,350	None	None	\$10,350
VA-14-0	\$11,050	None	None	\$11,050
VB-10-1	\$11,050	\$525	\$250	\$11,825

- Notes:
- (1) Standard vehicle cost includes the basic van and standard ancillary equipment.
 - (2) WCP = Wheelchair Position; costs include the total of all WCP for the designated vehicle.
 - (3) Total of Basic Vehicle. This cost includes the standard vehicle plus any optional wheelchair transporting capabilities.
 - (4) When completing the project budget in the application, use the estimated costs for standard vehicle, wheelchair ramp and WCP on the corresponding lines; the estimated total of basic vehicle is for information purposed only and is NOT to be used in calculating the project budget.

Optional Equipment Available

<u>Equipment</u>	<u>Estimated Additional Cost</u>
Air Conditioning	\$1150
Larger Engine Size	\$ 225
Radial Tires	\$ 275
Running Boards	\$ 250
Accessibility Symbol (For VB-10-1, only)	\$ 25
Driver Hand Controls	\$ 475
Two-way FM Radio	\$1300 (plus cost of any special radio features)

A. VAN SERIES (cont.)

3. CONVERTED VANS (VC's)

Vehicles Available

Vehicle Designation	Estimated Costs(4)			
	Standard Vehicle(1)	Wheelchair Lift	WCP(2) (All)	Total of Basic Vehicle(3)
VC-13-0	\$15,050	None	None	\$15,050
VCS-10-1	\$15,250	\$1,900	\$175	\$17,325
VCS-8-2	\$15,100	\$1,900	\$350	\$17,350
VCS-6-3	\$14,950	\$1,900	\$525	\$17,375
VCR-10-1	\$15,250	\$1,900	\$175	\$17,325
VCR-8-2	\$15,100	\$1,900	\$350	\$17,350
VCR-6-3	\$14,950	\$1,900	\$525	\$17,375

- Notes:
- (1) Standard vehicle cost includes converted van and all standard ancillary equipment.
 - (2) WCP = Wheelchair Positions; costs include the total of all WCP for the designated vehicle.
 - (3) Total of Basic Vehicle. This cost includes the standard vehicle plus any optional wheelchair transporting capabilities.
 - (4) When completing the project budget in the application, use the estimated costs for standard vehicle, wheelchair lift and WCP on the corresponding lines; the estimated total of basic vehicle is for information purposes only and is NOT to be used in calculating the project budget.

B. LIGHT TRANSIT VEHICLE SERIES

1. LIGHT TRANSIT VEHICLES (LTV)

Vehicles Available

Body Size	Vehicle Designation	Estimated Costs(4)			
		Standard Vehicle(1)	Wheelchair Lift	WCP(2) (All)	Total of Basic Vehicle(3)
25 Passenger	LTV-25-0	\$30,350	None	None	\$30,350
	LTV-19-1	\$30,050	\$2,300	\$175	\$32,525
	LTV-17-2	\$29,950	\$2,300	\$350	\$32,600
	LTV-15-3	\$29,850	\$2,300	\$525	\$32,675
	LTV-11-4	\$29,700	\$2,300	\$700	\$32,700
21 Passenger	LTV-21-0	\$27,200	None	None	\$27,200
	LTV-15-1	\$26,900	\$2,300	\$175	\$29,375
	LTV-13-2	\$26,800	\$2,300	\$350	\$29,450
	LTV-11-3	\$26,700	\$2,300	\$525	\$29,525
17 Passenger	LTV-17-0	\$23,050	None	None	\$23,050
	LTV-11-1	\$22,800	\$2,300	\$175	\$25,275
	LTV- 9-2	\$22,700	\$2,300	\$350	\$25,350
	LTV- 7-3	\$22,600	\$2,300	\$525	\$25,425
14 Passenger	LTV-14-0	\$19,700	None	None	\$19,700
	LTV-10-1	\$19,700	\$2,300	\$175	\$22,175
	LTV- 8-2	\$19,500	\$2,300	\$350	\$22,150
	LTV- 6-3	\$19,350	\$2,300	\$525	\$22,175

- Notes:
- (1) Standard vehicle cost includes LTV and all standard ancillary equipment.
 - (2) WCP = Wheelchair Positions; costs include the total of all WCP for the designated vehicle.
 - (3) Total of Basic Vehicle. This cost includes the standard vehicle plus any optional wheelchair transporting capabilities.
 - (4) When completing the project budget in the application, use the estimated costs for standard vehicle, wheelchair lift and WCP on the corresponding lines; the estimated total of basic vehicle is for information purposes only and is NOT to be used in calculating the project budget.

LTV (cont.)

Optional Equipment Available

<u>Equipment</u>	<u>Estimated Additional Cost</u>
Jump Seat Option:	
For LTV-19-1; 15-1; 11-2; 10-1 (both opts.)	\$ 175
For LTV-17-2; 13-2; 9-2; 8-2 (both opts.)	\$ 350
For LTV-15-3; 11-3; 6-3 (opt. 2)	\$ 525
For LTV-11-4; 7-3; 6-3; (opt. 1)	\$ 700

Equipment	Body Size			
	25 pass.	21 pass.	17 pass.	14 pass.
Air Conditioning	\$3,300	\$2,800	\$2,300	\$1,400
Radial Tires	\$ 700	\$ 650	\$ 600	\$ 375

Custom Seats Option:

For LTV-25-0	\$5000
For LTV-21-0	\$4200
For LTV-19-1	\$3800
For LTV-17-2; 17-0	\$3400
For LTV-15-3; 15-1	\$3000
For LTV-14-0	\$2800
For LTV-13-2	\$2600
For LTV-11-4; 11-3; 11-1	\$2200
For LTV-10-1	\$2000
For LTV- 9-2	\$1800
For LTV- 8-2	\$1600
For LTV- 7-3	\$1400
For LTV- 6-3	\$1200

Accessibility Symbols	\$ 25
Driver Hand Controls	\$ 475
Two-way FM Radio	\$1300 (plus cost of any special radio features)

C. BUS SERIES

1. MODIFIED SCHOOL BUS (BA's)

Vehicles Available

Vehicle Designation	Estimated Costs(4)			
	Standard Vehicle(1)	Wheelchair Lift	WCP(2) (All)	Total of Basic Vehicle(3)
BA-17-0	\$22,400	None	None	\$22,400
BA-21-0	\$22,850	None	None	\$22,850
BA-25-0	\$23,350	None	None	\$23,350
BA-31-0	\$23,800	None	None	\$23,800
BA-11-2	\$23,100	\$2,300	\$ 250	\$24,650
BA-15-2	\$22,850	\$2,300	\$ 250	\$25,400
BA-19-2	\$23,150	\$2,300	\$ 250	\$25,700
BA-11-4	\$22,650	\$2,300	\$ 500	\$25,450
BA-15-4	\$22,950	\$2,300	\$ 500	\$25,750
BA-11-6	\$22,750	\$2,300	\$ 750	\$25,800
BA- 7-8	\$22,650	\$2,300	\$1,000	\$25,950

- Notes:
- (1) Standard vehicle cost includes bus and all standard ancillary equipment.
 - (2) WCP = Wheelchair Positions; costs include the total of all WCP for the designated vehicle.
 - (3) Total of Basic Vehicle. This cost includes the standard vehicle plus any optional wheelchair transporting capabilities.
 - (4) When completing the project budget in the application, use the estimated costs for standard vehicle, wheelchair lift and WCP on the corresponding lines; the estimated total of basic vehicle is for information purposes only and is NOT to be used in calculating the project budget.

Bus A (cont.)

Optional Equipment Available

Vehicle Designation	Estimated Additional Costs		
	Air Conditioning	Jump Seats	Radial Tires
BA-17-0	\$2,850	N/A	\$425
BA-21-0	\$3,350	N/A	\$475
BA-25-0	\$3,800	N/A	\$525
BA-31-0	\$5,250	N/A	\$625
BA-11-2	\$3,350	\$ 350	\$475
BA-15-2	\$3,800	\$ 350	\$525
BA-19-2	\$4,750	\$ 350	\$575
BA-11-4	\$3,800	\$ 700	\$525
BA-15-4	\$4,750	\$ 700	\$525
BA-11-6	\$4,750	\$1050	\$575
BA- 7-8	\$5,250	\$1400	\$625

N/A = Not Available on these vehicles

<u>Equipment</u>	<u>Estimated Additional Cost</u>
Accessibility Symbols	\$ 25
Driver Hand Controls	\$ 475
Two-way FM Radio	\$1,300 (plus cost of any special radio features)

C. BUS SERIES (cont.)

1. LIGHT BUS (BB's)

Vehicles Available

Vehicle Designation	Estimated Costs(4)			
	Standard Vehicle(1)	Wheelchair Lift	WCP(2) (All)	Total of Basic Vehicle(3)
BB-17-0	\$23,800	None	None	\$23,800
BB-21-0	\$24,750	None	None	\$24,750
BB-25-0	\$25,700	None	None	\$25,700
BB-31-0	\$26,650	None	None	\$26,650
BB-11-2	\$24,000	\$2,300	\$ 250	\$26,550
BB-15-2	\$24,950	\$2,300	\$ 250	\$27,500
BB-19-2	\$26,550	\$2,300	\$ 250	\$29,100
BB-11-4	\$25,500	\$2,300	\$ 500	\$28,300
BB-15-4	\$26,400	\$2,300	\$ 500	\$29,200
BB-11-6	\$26,700	\$2,300	\$ 750	\$29,250
BB- 7-8	\$26,750	\$2,300	\$1,000	\$30,050

- Notes:
- (1) Standard vehicle cost includes bus and all standard ancillary equipment.
 - (2) WCP = Wheelchair Positions; costs include the total of all WCP for the designated vehicle.
 - (3) Total of Basic Vehicle. This cost includes the standard vehicle plus any optional wheelchair transporting capabilities.
 - (4) When completing the project budget in the application, use the estimated costs for standard vehicle, wheelchair lift and WCP on the corresponding lines; the estimated total of basic vehicle is for information purposes only and is NOT to be used in calculating the project budget.

Bus B (cont.)

Optional Equipment Available

Vehicle Designation	Estimated Additional Costs			
	Air Conditioning	Jump Seats	Radial Tire	Custom Seats
BB-17-0	\$2,850	N/A	\$425	\$3,400
BB-21-0	\$3,350	N/A	\$475	\$4,200
BB-25-0	\$3,800	N/A	\$525	\$5,000
BB-31-0	\$5,250	N/A	\$625	\$6,200
BB-11-2	\$3,350	\$ 350	\$475	\$2,200
BB-15-2	\$3,800	\$ 350	\$525	\$3,000
BB-19-2	\$4,750	\$ 350	\$575	\$3,800
BB-11-4	\$3,800	\$ 700	\$525	\$2,200
BB-15-4	\$4,750	\$ 700	\$575	\$3,000
BB-11-6	\$4,750	\$1050	\$575	\$2,200
BB- 7-8	\$5,250	\$1400	\$625	\$1,400

N/A = Not Available on these vehicles

<u>Equipment</u>	<u>Estimated Additional Cost</u>
Accessibility Symbols	\$ 25
Driver Hand Controls	\$ 475
Two-way FM Radio	\$1,300 (plus cost of any special radio features)

C. BUS SERIES (cont.)

1. LIGHT TRANSIT BUS (BC's)

Vehicles Available

Vehicle Designation	Estimated Costs(4)			
	Standard Vehicle(1)	Wheelchair Lift	WCP(2) (All)	Total of Basic Vehicle(3)
BC-17-0	\$20,500	None	None	\$20,500
BC-11-1	\$20,500	\$2,300	\$ 175	\$22,975
BC- 9-2	\$20,400	\$2,300	\$ 350	\$23,050
BC- 7-3	\$20,300	\$2,300	\$ 525	\$23,125

- Notes:
- (1) Standard vehicle cost includes bus and all standard ancillary equipment.
 - (2) WCP = Wheelchair Positions; costs include the total of all WCP for the designated vehicle.
 - (3) Total of Basic Vehicle. This cost includes the standard vehicle plus any optional wheelchair transporting capabilities.
 - (4) When completing the project budget in the application, use the estimated costs for standard vehicle, wheelchair lift and WCP on the corresponding lines; the estimated total of basic vehicle is for information purposes only and is NOT to be used in calculating the project budget.

Optional Equipment Available

Estimated Additional Costs (Total For That Option)							
Vehicle Designation	Jump Seats	Custom Seats	Air Conditioning	Radial Tires	Accessibility Symbols	Driver Hand Controls	Two-Way FM Radio
BC-17-0	0	\$3,400	\$2,300	\$550	\$25	\$475	\$1,300
BC-11-1	\$175	\$2,200	\$2,300	\$550	\$25	\$475	\$1,300
BC- 9-2	\$350	\$1,800	\$2,300	\$550	\$25	\$475	\$1,300
BC- 7-3	\$525	\$1,400	\$2,300	\$550	\$25	\$475	\$1,300

bPT22C

GA-421-428/3450