

GUIDELINES FOR MAKING PEDESTRIAN CROSSING STRUCTURES ACCESSIBLE

Research, Development,
and Technology

Turner-Fairbank Highway
Research Center
6300 Georgetown Pike
McLean, Virginia 22101



U.S. Department
of Transportation

**Federal Highway
Administration**

Report No.
FHWA-IP-84-6

Implementation Manual
August 1984

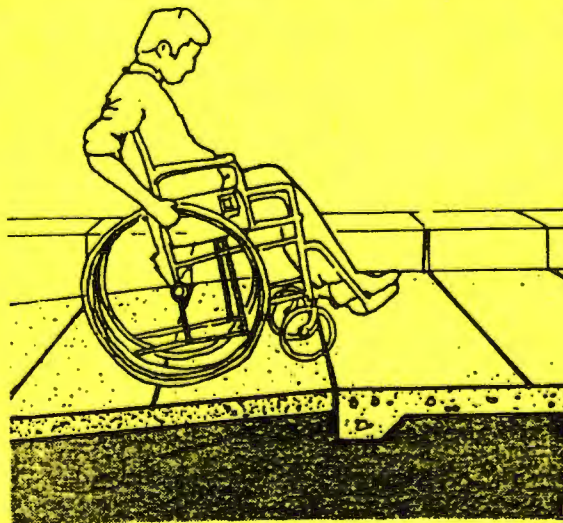

MTA LIBRARY

public through the National Technical Information Service, Springfield, Virginia 22161

NA
2545
.P5
R53
1984

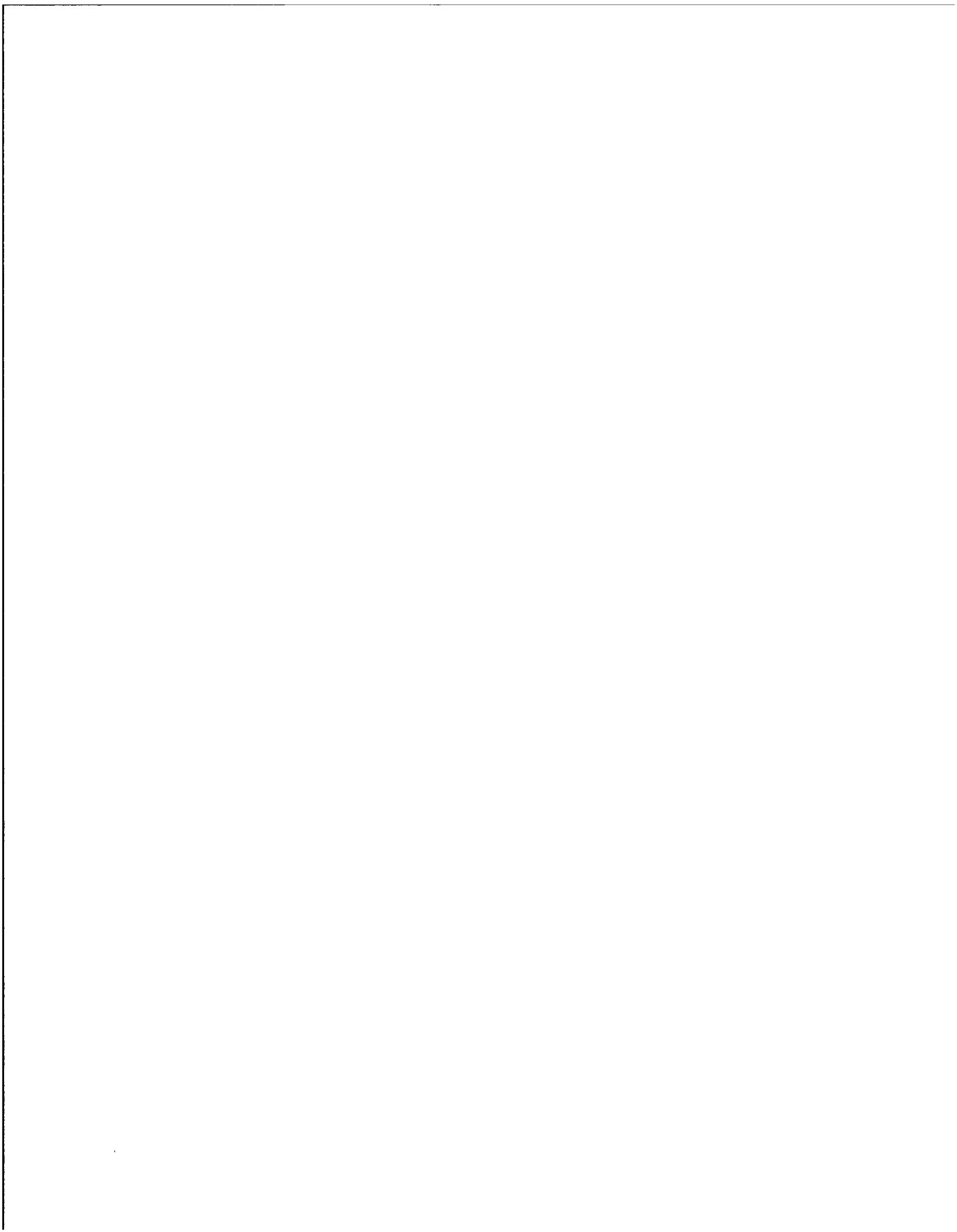

1. Report No. FHWA-IP-84-6		2. Government Accession No.		3. Recipient's Catalog No.	
4. Title and Subtitle Guidelines for Making Pedestrian Crossing Structures Accessible				5. Report Date August 1984	
				6. Performing Organization Code HRT-20	
7. Author(s) Messrs. Richard A. Richter and Charles L. King				8. Performing Organization Report No.	
9. Performing Organization Name and Address Federal Highway Administration 6300 Georgetown Pike McLean, Virginia 22101				10. Work Unit No. 31ZN028	
				11. Contract or Grant No.	
12. Sponsoring Agency Name and Address*				13. Type of Report and Period Covered Implementation Manual	
				14. Sponsoring Agency Code HRT-20	
15. Supplementary Notes Implementation Task N Manager: Peter Hatzi R&D FCP Project IN Manager: John Fegan					
16. Abstract In designing and locating pedestrian over- and undercrossing structures, accessibility for handicapped persons is an important consideration. Features needed to provide accessibility should be incorporated into the structures unless it is shown that it is impractical to do so. Even when full accessibility is not provided, as many of the handicapped population as possible should be accommodated on the pedestrian structure. The types of features used most commonly on over-and undercrossing structures are determined by the needs of two major groups of handicapped users -- those who use wheelchairs and those who are visually impaired. This latter group can be divided into those with limited vision and those who cannot see at all. Completed research provides an indication of the accessibility requirements of handicapped persons who use wheelchairs or are visually impaired. The maximum ramp grades and distances between resting places needed by persons in wheelchairs are provided. Design requirements necessary to accommodate persons with other types of ambulatory disabilities are also described. Features necessary to accommodate both persons with limited vision and those who cannot see at all are detailed. The necessity of considering the pedestrian overpass or underpass as a part of a broader network of accessible routes is outlined.					
17. Key Words Pedestrian, Elderly and Handicapped Pedestrian Crossings, Accessibility			18. Distribution Statement No restriction. This document is available through the National Technical Information Service, Springfield, VA, 22161.		
19. Security Classif. (of this report) Unclassified		20. Security Classif. (of this page) Unclassified		21. No. of Pages 31	22. Price



Table of Contents

	Page
I. Introduction	1
A. The Accessible Network	1
B. Features Required for Accessibility	2
C. Wheelchair Users	5
D. Blind Pedestrians	5
II. Pedestrian Crossing Planning, Design and Construction	8
A. Choosing the Crossing Site	8
B. Preparation of Preliminary Crossing Layout	9
C. Preparation of Crossing Design and Details	10
D. Construction	11
III. Design Details	11
A. End Connection, Approach and Structure Walkways	11
1. Walkway Widths	11
2. Surfaces	12
3. Maintenance	12
4. Gradients	13
B. Approach Ramps	13
1. Ramp Lengths and Gradients	13
2. Ramp Cross Slopes	14
3. Ramp Landings	14
C. Approach Stairs	14
1. Surfaces	14
2. Tactile Warning Markers	16
3. Stair Runs	16
4. Treads and Risers	16
5. Types of Steps	16
6. Approach Stair Widths	17
7. Hazardous Layouts	17
8. Stair Landings	17
D. Railings and Handrails	17
1. Rail Heights	17
2. Handrail Extensions	19
3. Handrail Design	19
4. Balustrades and Protective Enclosures	20
5. Handrail Load Capacity	21
E. Pedestrian Barricades	21
F. Lighting	22
G. Signs	22
1. Location of Signs	22
2. Sign Legibility	23
3. Special Signs and Signals for Handicapped Pedestrians	23
4. Tactile Area Layouts for Blind Pedestrians	25
IV. Definitions	26

List of Tables

Table	Page
1. Recommended design features for accessibility.	3,4
2. Design features for wheelchair travelers.	5
3. Design features for blind pedestrians.	8
4. Choosing the crossing site.	8
5. Preparation of preliminary crossing layout.	9
6. Preparation of crossing design and details.	10
7. Maximum allowable ramp lengths and gradients.	14
8. Slip resistance: Coefficient of friction for selected walkway materials against leather.	16
9. Acceptable tread widths for various riser heights.	16

List of Figures

Figure	Page
1. Recommended minimum width for off-structure walks.	11
2. Passing area.	11
3. Recommended minimum width for walkways on approaches and structures.	11
4. Maximum permissible size of expansion and construction joints.	12
5. Surface transition to be kept flush.	12
6. Recommended edges for walkway.	12
7. Recommended detectable protective barriers.	13
8. Walkways should be kept clear of overhanging branches and shrubs.	13
9. Maximum transverse slope for walks.	13
10. Maximum recommended cross slope of ramp surface.	14
11. Rest stop landing locations for various ramp grades.	15
12. Ramp and walkway slip resistance.	15
13. Tread slope.	16

List of Figures (cont.)

Figure	Page
14. Tactile signal.	17
15. Recommended minimum landing width.	17
16. Guardrail height.	18
17. Stair handrail height.	18
18. Ramp handrail height.	18
19. Handrail for children.	18
20. Stair handrail extension.	19
21. Ramp handrail extension.	19
22. Handrail projection.	19
23. Handrails allowing natural opposing grip.	20
24. Handrail mounting.	20
25. Avoid rough textured finish on wall.	20
26. Avoid recessed handrail.	20
27. Horizontal handrail member spacing.	21
28. Vertical handrail member spacing.	21
29. Hazardous barricades.	21
30. Detectable barricades.	22
31. Angle of view for ambulatory individuals.	22
32. Angle of view for wheelchair bound individuals.	22
33. View restricted with limited head movement.	23
34. Raised characters detectable to the visually impaired.	23
35. The international symbol of accessibility.	24
36. Detectable junction between walkway and street.	24
37. Detectable crosswalk markings.	24
38. Street furniture strip.	24
39. "Checkered" metal plate as a landmark warning of adjacent stairs.	25
40. Grass area as a shoreline device.	25
41. Planter used as a shoreline device.	25
42. Directional box (planter) used as a landmark and directional aid.	26

GUIDELINES FOR MAKING PEDESTRIAN CROSSING STRUCTURES ACCESSIBLE

I. Introduction

Since World War II, grade separation structures for pedestrians have become a standard part of our roadway systems in urban and rural locations. Most pedestrian crossing structures have been built over freeways; others span minor roads, rivers and railroad tracks; and some are underpasses.

This manual includes information on designing pedestrian over- and undercrossing structures for elderly and handicapped pedestrians. A more extensive treatment of design features which aid elderly and handicapped pedestrians can be found in "Development of Priority Accessible Networks, An Implementation Manual"(1). The recommendations in that publication as well as those contained in this manual are based on a series of research studies carried out at the Pedestrian Research Laboratory of the Georgia Institute of Technology, Atlanta, Georgia.

The codes and standards covering requirements for elderly and handicapped pedestrians, which are in force in the various jurisdictions of the United States, are not uniform and, therefore, discrepancies and conflicts may occur with the recommendations contained in this manual. In certain respects, these recommendations also may differ from the American National Standards Institute (ANSI) standards (1980) and the Architectural and Transportation Barriers Compliance Board (ATBCB) guidelines and requirements (1982). For these reasons, the contents of this manual must be considered only as general guidance, and the designer must be governed by the statutes and regulations covering the proposed crossing structure location.

(1) John Templer, et al, Development of Priority Accessible Networks: Provisions for the Elderly and Handicapped Pedestrians, Federal Highway Administration, Implementation Manual (FHWA-IP-80-8) (Washington: Government Printing Office, 1980).

In designing and locating overpass and underpass structures so they serve the elderly and handicapped pedestrians, cost, environmental factors, and availability of sites should be considered, as well as alternate routes which allow the elderly and handicapped to avoid use of a crossing structure. Most of the features necessary to accommodate elderly and handicapped pedestrians can be included when building a structure, at little or no additional cost. Features such as extremely long ramps or elevators, necessary at particular locations to provide accessibility, may be expensive, but can be justified by anticipated demand. At some locations, it may be economically impractical to provide a fully accessible crossing structure, in which case accessibility measures should be installed as closely to the desired values as possible. At locations where the profile of surrounding land is such that access by certain groups of elderly and handicapped pedestrians is not feasible or where the structure is so remotely located it would be impractical for these groups to reach it, the designer may need to use discretion in selecting accessibility features. The accessibility features often have value to able-bodied persons and should not be omitted without weighing all the benefits. If the designer finds it is impractical or imprudent to make a structure fully accessible, provisions for obtaining exceptions to codes and standards are available. The designer should become familiar with the various local, State, and Federal laws, codes, and standards governing accessibility and the application procedures for obtaining waivers.

A. The Accessible Network

A crossing structure carefully designed for accessibility still may not be usable by some elderly and disabled pedestrians if the sidewalks and walkways leading to the structure are not accessible. If, for example, it is necessary to cross a road to reach an overcrossing, and no curb cuts exist at the crosswalk, wheelchair users may not be able to reach the structure. A procedure called the Priority Accessible Network (PAN) gives planners and designers a systematic approach for selecting and installing improvements through the identification of

priority routes for the initial improvements. The procedure aids in identifying critical sections of selected walkway systems through inventories of accessibility barriers and identification of accessibility enhancement opportunities.

The process for development of a PAN is described in the Development of Priority Accessible Network manual (FHWA IP-80-8). The implementation of a PAN first involves the identification of districts representing areas where elderly and disabled pedestrians reside, work, or visit. Routes are identified within and between these districts. Each selected route is improved according to priorities set out in a master plan. Each district is also upgraded according to the priorities of the master plan, eventually leading to complete accessibility of the entire community. An initial PAN consists of several principal routes developed to be fully accessible.

The network thus formed in one district is then expanded to connect with networks in other districts. Each developed route within a given network is made up of a connecting sequence of components, such as street crossings connecting to sidewalk segments. An over- or undercrossing structure may be considered a component in such a network. The components are then made up of various elements such as curb ramps, street lights or pavement markings.

Accessibility is achieved by the use of appropriate design elements (barrier removing countermeasures). An example of a countermeasure is a curb ramp used to make the curb element of an overcrossing component accessible.

In considering where to locate a pedestrian over- or undercrossing structure, the structure designer should know which routes are or will be made accessible to the disabled population within the neighboring district(s) served. What laws, codes or standards must be addressed? If the routes leading to the structure are currently not accessible, will they be made so later as a staged improvement? Is there another location for the structure where accessibility could be more simply provided? Should a route leading to the structure be fully developed as part of the structure project? Even if local codes do not require them, the designer should consider the features suggested in this guide and make every effort to provide for a minimum level of accessibility.

The strategy for locating and planning pedestrian crossing structures is discussed in the following section. Pedestrian over- and undercrossing facilities are considered in terms of three components: end connections, approaches, and the crossing structure. The end connection is where the facility meets the adjoining roads or walkways. The approaches are the stair or ramp walkways that connect the structure to the end connection, and the crossing structure is the segment that spans across or tunnels under the road, river, etc.

B. Features Required for Accessibility

The recommended strategy for making crossings accessible is to select a specific set of design features from those identified in this manual for each of the three components of a crossing structure. This manual will aid the designer by 1) describing the specific accessibility features and explaining why they are needed, 2) providing guidance on the application of the selected features, and 3) giving the designer guidance on the use of optional features.

A familiarity with the nature of the disabling conditions elderly and handicapped persons have and the measures which provide accessibility is desirable for the designer in that it enables him or her to avoid inadvertently designing in potential hazards or accessibility barriers. Also important to the designer is an understanding of how a disabled person moves through the travel environment.

Table 1 lists some of the common design features which will assist elderly and handicapped pedestrians and describes the disability which makes inclusion of those features desirable for pedestrian crossings. The table may also be used as a checklist when reviewing any portion of a proposed design. Definitions of terms can be found in Section IV of this manual. A question the designer needs to consider in choosing the design features for a structure is whether or not groups of pedestrians with the disabling characteristics listed in Table 1, will be using the proposed structure.

Various types of disabilities and differing severities create a range of mobility problems for elderly and handicapped pedestrians. Some of these problems are satisfied by only minor aids provided on the pedestrian facilities.

Conversely, few handicapped pedestrians can be singled out as depending almost completely on the condition and design of the pedestrian facilities for mobility. The two most critically affected are manual wheelchair users and blind pedestrians.

Table 1. Recommended design features for accessibility

Design Features	Reason for Providing	Criteria References
1. Stopping or resting places (landings)	Elderly and handicapped pedestrians lack stamina and strength.	GSA - AS Sec. 5.1 * ATBCB - MGRAD ** Section 1190.70
2. Benches	Periodic resting places with benches provide seating for pedestrians and allow them to regain strength.	
3. Special signal timing for pedestrians	The slower movement and reaction time of elderly and handicapped pedestrians requires more crossing time at signalized intersections.	
4. Detectable warning cues	Blind persons need to be alerted to potential hazards such as stairs, intersections, driveways, etc.	ATBCB - MGRAD ** Section 1190.190 (reserved)
5. Detectable guidance cues	Where the natural cues are not available, supplementing guidance cues are useful.	
6. Protection from low projections	Overhead projections avoided by sighted persons are hazardous to visually impaired pedestrians.	GSA - AS Sec. 5.13 * ATBCB - MGRAD ** Section 1190.50 ANSI ***
7. Tactile signs	Route layout signs for visually impaired pedestrians are needed for guidance.	GSA - AS Sec. 5.1 * ATBCB - MGRAD ** Section 1190.200 (reserved) ANSI ***
8. Large legend signs	Handicapped persons with limited vision can often read signs if the letters are large.	GSA * ATBCB ** ANSI ***
9. Ramps with moderate grades	Handicapped persons in wheelchairs can utilize over- or undercrossings if ramp access is provided.	GSA - AS Sec. 5.1 * ATBCB - MGRAD ** Section 1190.70

* General Services Administration - Accessibility Standard (GSA - AS)

** Architectural and Transportation Barriers Compliance Board - Minimum Guidelines and Requirements for Accessible Design (ATBCB - MGRAD), 36 CFR Part 1190.

*** American National Standards Institute Standard (ANSI) A 117.1 - 1980

Table 1 (cont.)

Design Features	Reasons for Providing	Criteria References
10. Non-heat conducting handrails	Some elderly and handicapped persons are dependent on handrails and may be injured because of a high sensitivity to heat or cold.	ATBCB - MGRAD ** Section 1190.90 ANSI ***
11. Dual access facilities (steps and ramps)	Handicapped persons on crutches or using canes often find stairs easier to negotiate than ramps.	
12. Telephones at strategic access points	Telephones at convenient locations are needed by elderly and handicapped persons to call for assistance.	GSA - AS Sec. 5.8 * ATBCB - MGRAD ** Section 1190.20 ANSI ***
13. Wide walkways	Plenty of travel room encourages movement by elderly and handicapped pedestrians.	GSA - AS Sec. 4.2 * ATBCB - MGRAD ** Section 1190.50 ANSI ***
14. Stable slip resistant surfaces	Elderly and handicapped pedestrians are not agile and need good footing for confidence. Wheelchairs on ramps need slip resistance.	GSA - AS Sec. 4.2 * ATBCB - MGRAD ** Section 1190.115 ANSI ***
15. Water fountains	Elderly and handicapped pedestrians need frequent refreshment when traveling.	GSA - AS Sec. 5.7 * ATBCB - MGRAD ** Section 1190.116 ANSI ***
16. Gates and doors which are easily opened	Elderly and handicapped pedestrians cannot open and close gates and heavy doors.	GSA - AS Sec. 5.3 *
17. Signs located within pedestrians' normal vision	Signs mounted the standard height may be missed by pedestrians in wheelchairs or elderly pedestrians with stooped stature.	GSA - AS Sec. 5.11 * ANSI ***
18. Slip resistant standardized stairs	Some elderly and handicapped pedestrians find stairs easier to use than ramps when stairs are properly designed.	GSA - AS Sec. 5.4 * ATBCB - MGRAD ** Section 1190.80 ANSI ***
19. Area lighting	Persons with poor eyesight require well lighted areas to recognize landmarks, signs and other guidance features.	

* General Services Administration - Accessibility Standard (GSA - AS)

** Architectural and Transportation Barriers Compliance Board - Minimum Guidelines and Requirements for Accessible Design (ATBCB - MGRAD), 36 CFR Part 1190.

*** American National Standards Institute Standard (ANSI) A 117.1 - 1980

C. Wheelchair Users

Wheelchair users, as a group, are people with various disabilities (frequently multiple disabilities) and they may be elderly with degenerative conditions. Each disability has its own physical consequences with respect to strength, stamina, coordination, etc. The physical condition of the wheelchair user is affected by factors such as age, experience, training, attitude and general health.

The typical hand-propelled wheelchair is a light unsprung vehicle with limited stability. The wheels are narrow and can become trapped in gratings. Like the heavier power-propelled wheelchair, it can also become bogged down in gravel, mud, or any soft surface. Because the hand-propelled wheelchairs are more easily restricted by structure grades, they are used as a design vehicle to represent all wheelchairs. Rough hard surfaces such as cobblestones, uneven brick paving and concrete surfaces with rough joints will jolt a wheelchair and may even cause pain for the wheelchair user. An irregular expansion joint or a projection as little as 1/2-inch high may be too much for some wheelchair users to traverse, and may be sufficient to jolt them from their seats.

Many wheelchair users can use ramps without aid, but the effort they must exert is substantial; the physical demands of climbing ramps depend on the length and steepness of the ramp. Wheelchair users, as a group, tend to have less energy and stamina than able-bodied people, and therefore, ramps for them should be short with flat grades. These two requirements, however, tend to conflict with each other, the longer the ramp, the flatter the grade and vice versa. To minimize out-of-direction travel as well as facility cost, ramp lengths should be designed to be as short as possible while maintaining grades within acceptable limits. Where approach terrain and access points allow economical use of approach embankments, flatter grades should be used to help wheelchair users to move easier.

If a walkway has a cross slope, the wheelchair user must use more effort to keep the wheelchair from veering toward the downhill side. Cross slopes, therefore, should be limited to not more than 1 in 50.

Some wheelchair users can propel their chairs with remarkable precision through an opening with no more than 1/4-in. clearance on either side. Others, by the nature of their disability, have more strength on one side of their body, and swerve from side to side as they travel. For this reason, gates through which wheelchair users are to pass need to be at least 32-in. wide.

The wheelchair user needs adequate walkway width for passage and turning, and also needs longitudinal distance within which to decelerate and stop.

Despite their disabilities, wheelchair users can use over- and undercrossings efficiently when the appropriate design features are provided. The recommended design features for wheelchair travelers are summarized in Table 2.

D. Blind Pedestrians

According to the American Foundation for the Blind (AFB), about 1.7 million people in the United States are severely visually impaired. This includes those "completely blind," those "legally blind," and those not legally blind but who have a need for special travel aids. About 400,000 persons are with no usable vision and readily classified as "blind." The blind pedestrian represents a model for providing some mobility aids on pedestrian facilities because certain design elements of use to blind persons will also be of equal or greater use to persons with partial sight. For other features such as signage criteria, partially sighted persons will serve as the model. According to the AFB, 65 percent of the blind people in the United States are 65 years old or more, with only 4 percent under 25. Because many blind persons are old, they often have other disabilities such as poor balance and low agility, in addition to their blindness.

Design features provided to aid blind pedestrians offer three services: orientation, way finding and warning. Orientation devices such as tactile guidance strips and tactile maps allow the blind pedestrian to know where things are, the relationship of furniture, streets, building entrances, and the layout of buildings to themselves. Way finding through tactile route signs and turn markers provides route information which permits the blind pedestrian to stay on a specific route and avoid hazards of nonimproved routes. Warnings are provided by markers such as tactile strips placed to separate walkways from areas of danger.

Table 2. Design features for wheelchair travelers.

Design Features	Component	Principal Benefit
1. Accessible connection from the pedestrian network to the crossing structure.	End connection	Insures usefulness of the crossing to wheelchair users.
2. Direct travel route between major travel generators	Structure	Insures the structure is located for maximum service to wheelchair users.
3. Lighting	End connection, approach, structure	Insures that pedestrian hazards are minimized.
4. Stable, firm, slip resistant surface	Approach, structure, end connection	Prevents wheels from slipping.
5. Adequate turning and passing spaces	End connection	Provides freedom of movement for turning wheelchairs.
6. Wide walkways	Approach, structure	Insures users can meet and pass easily.
7. Low curbs on crossing ramps and structure	Approach, structure	Provides a safeguard from wheelchairs rolling off structure and approach ramp.
8. Short, moderately graded ramps	Approach	Insures wheelchair users can climb ramps.
9. Landings	Approach	Allows wheelchair users opportunities to rest while climbing ramps.
10. Handrails	Approach, structure	Allows wheelchair users handholds to aid in ramp climbing.

As blind people become familiar with a particular location (become oriented) their strategy for mobility may change. Rather than travel from point-to-point, or remembered landmark to remembered landmark, they may rely on a mental map of their setting that represents the spatial relationship of important features. For example, if a blind person is using a crossing structure, he or she may memorize a string of landmarks, such as the location of a sign, a path, a wall, the entrance to the crossing, or may develop an overall mental picture of the site and crossing structure. This mental image is most useful since it allows the traveler

flexibility and confidence (missing a single landmark in a point-to-point strategy may lead to confusion). A mental map may be almost impossible to acquire if a route is too complex. Visually impaired travelers are generally taught to keep track of the cardinal points - North, South, East, and West. Simple routes with right-angle turns support those directions and aid in mental mapping. Complex over- and undercrossing plan layouts with irregular angle turns and twisting approach paths should be avoided. Where crossings change direction or have multiple entrances and exits, tactile signs supplemented by braille showing route alignment are desirable.

The long cane is the most common mobility aid used by blind pedestrians and is used to sweep the path in front of the traveler. The cane is typically held at waist level and angled down. Blind persons are trained to sweep an area roughly as wide as the shoulders (approximately 24 in.), although most actually sweep an area much wider. A blind person, with experience, can become adept at detecting and evaluating various kinds of environmental cues such as walls, curbs, paving changes, or posts. Cane users are taught to make use of shorelines made up of walkway facility features such as the edge of a sidewalk, or special guidance strips, that help them to stay on a path; and landmarks, which are memorable points (lamp poles, mail boxes, curbs, etc.) that help the blind pedestrian remain oriented. The downward angle at which the cane is held, however, may cause the user to miss overhanging objects, or anything that is more than 27 in. above the ground.

Because their mobility, skills and physical disabilities may vary considerably, the travel strategies of blind pedestrians may differ also. Unusual situations at over- and undercrossings, as at other locations on a pedestrian facility, can be particularly difficult or hazardous. When a pedestrian trip involves going over a crossing structure, a typical blind pedestrian using a cane must first find the correct place to turn to reach the crossing. The location must be identified as the correct place to turn and distinguished in some way from all other possible turn locations. This problem is greatly reduced if the designer provides the turn-off location with some recognizable distinguishing feature or landmark such as a signpost or tactile marker.

After the pedestrian has found the correct place to turn, there remains the problem of locating the approach to the structure. At some existing pedestrian crossings, the traveler may be required to cross a large open space or parking lot before encountering the actual access ramp or stairs. This is a very difficult task for blind persons. As cane users, they typically navigate using shorelines and may inadvertently become disoriented when crossing a large open space. This may cause them difficulty in locating the entrance to the crossing or, in exiting, to locate some recognizable reference feature they need to continue their journey. To avoid this problem, connect the sidewalk to the crossing structure using a walkway with defined edges capable of being used as shorelines. This walkway should be clearly defined across the entire parking lot or open space.

When a traveler reaches the beginning of an approach component to a crossing, he or she must find the entrance to the ramp or stairs. The traveler must be sure the entrance encountered is the actual ramp or stairs to the over- and undercrossing rather than to another sidewalk or to a building. It is the responsibility of the designer to ensure the approach component to the structure is direct and unambiguous. In traversing through this component, the traveler must ascend or descend to the actual crossing. The design features most necessary are smooth handrails that turn before the stair or ramp turns to give the blind user some continual reference. Another useful guidance feature for blind pedestrians using canes is a low (2 in.) curb on the edges of the ramp. This curb can be used as a reference surface for the guidance cane.

Once on the crossing structure, a blind pedestrian may have relatively little difficulty, if it is a direct crossing. However, if choices are to be made, such as between a ramp or a stair, or between two different egress points, the blind pedestrian must be alerted. This can be done with a tactile route alignment sign, detectable tactile floor surface material, or some other sort of identifiable feature on the structure.

After the traveler has reached the opposite end of the crossing, he or she faces problems similar to those at the initial end connection. The traveler needs orientation and way finding features to find the appropriate pedestrian route. Here too, tactile signs, detectable surface treatments, or other identifying features are recommended.

The planning and design features recommended for blind pedestrians herein can be incorporated into almost any crossing structure. More elaborate design features are generally not needed on crossing structures and their approaches. The typical design features for the blind pedestrian are summarized in Table 3.

Table 3. Design features for blind pedestrians.

Design Features	Component	Principal Benefits
1. Simple plan layout for structure	Structure	Insures easy understanding of route in traversing structure.
2. Locating crossing structure at the most useful location	Structure, approach	Insures a direct travel path.
3. Tactile guidance strips and surfaces	End connection, approach	Insures a usable guidance reference system.
4. Tactile signs	End connections	Enables the blind pedestrian to locate crossing.
5. Handrails	Approach, structure	Provides guidance to the blind pedestrian while using the over- or undercrossing.

II. Pedestrian Crossing Planning, Design and Construction

The planning of the over- or undercrossing should incorporate considerations for elderly and handicapped pedestrians in each of the following four phases:

- * Choosing the Crossing Site
- * Preparation of Preliminary Crossing Layout
- * Preparation of Crossing Design and Details
- * Construction

After the decision is made that a pedestrian crossing is needed, a site should be selected

as nearly in a direct path between pedestrian generators (e.g. residences, shopping centers, senior citizen centers, etc.) and destinations as possible. It should then be reviewed for possible revisions to reduce costs, reduce access problems, or serve additional users.

A. Choosing the Crossing Site

Choosing an appropriate location for a pedestrian crossing structure depends on structural, access, and economic considerations. The coverage in this manual will be limited to the access aspects. The checklist in Table 4 should be considered when selecting a site. The factors below will apply to all three components of any proposed crossing structure.

Table 4. Choosing the crossing site.

Item	Action
1. Are the sidewalks or walkways in the vicinity of the site inaccessible?	Determine agency plans for making sidewalks accessible and coordinate action with structure plans.
2. Is the proposed site far from existing pedestrian walkways? Will it be difficult for blind people to find and will it be difficult for people with limited stamina to reach?	Investigate alternate locations to reduce travel distance.
3. Would pedestrians have to travel out of the way to use the structure between major origins and destinations?	Investigate a structure location as close to a direct line between major origins and destinations as possible.

B. Preparation of Preliminary Crossing Layout

The general layout of the crossing structure should be considered at the same time that the site planning takes place. In preparing the

preliminary structure layout, the crossing structure, the approaches and the end connections need to be matched to the site that has been chosen. The proposed layout should be evaluated using the checklist in Table 5.

Table 5. Preparation of preliminary crossing layout.

Item	Action
1. Does the crossing structure for the proposed site require long ramps?	Consider adding stairs in addition to ramps. Look for alternate locations where shorter ramps and stairs could be used.
2. Does the route from the site entrance to the crossing structure pass through a parking lot or open space?	Investigate alternative locations for end connections or provide detectable orientation and wayfinding cues. Be certain the pedestrian route is physically separated from traffic.
3. Are the end connection paths curved so they are difficult for the blind pedestrians to follow and to visualize?	Investigate the use of straight paths and right-angle turns.
4. Is the proposed layout so complicated it will be hard for the blind pedestrian to understand?	Revise layout to make access more direct.
5. Do the end connection paths leading to the structure area have steps?	Revise walkway routing.
6. Do the paths leading to the structure ramp more steeply than 5 percent?	Investigate a route with a gradient below 5 percent.
7. Is the crossing structure layout complex and difficult for the blind pedestrian?	Revise the layout to make it simple or simpler.
8. Does the end connection walkway curve and are directional changes less than 90 degrees?	Convert the walkway layout into tangents and 90-degree turns, wherever possible.
9. Is a circular (helical) ramp included in the crossing layout?	Design with a gradient flatter than the allowable.
10. Are there stairs or other dropoffs directly in the path of travel?	Design the layout so the stairs, etc., are not in the direct route of travel and provide tactile warning strips at the top of the stairs.

C. Preparation of Crossing Design and Details

After the preliminary structure layout has been developed only minor accessibility barriers in the three crossing components should remain. Major accessibility problems should have been taken care of by setting the grades, ramp widths and ramp lengths.

Recommendations for the barrier elements of the crossing structure, the approaches and the end connections are provided in Table 6. After insuring accessibility barriers do not exist, consider how many of the desirable (optional) features for elderly and handicapped pedestrians such as telephones, water fountains, and rest rooms will be made available.

Table 6. Preparation of crossing design and details.

Item	Action
1. Is the entrance to the crossing structure obvious to people with limited vision?	Provide for landmarks and signs.
2. Are the approaches leading to the structure narrow?	Widen approaches to 96" so two wheelchairs can pass.
3. Are there any places where a visually impaired pedestrian or a wheelchair user could fall off an edge?	Protect the pedestrians in that area with guardrail and curbs.
4. Are there any low overhanging trees or structures that could be dangerous to a person with limited vision?	Realign the path to avoid overhang, or design to avoid any constructed overhang.
5. Will the crossing be used by pedestrians with limited stamina?	Provide seats adjacent to the end connection path.
6. Is telephone service needed?	Provide an accessible public phone.
7. Is there more than one exit from the structure?	Provide tactile signs, detectable tactile surface treatments and other identifying features.
8. Is a ramp to be used?	Select a stable, firm, slip resistant material for the ramp surface with an acceptable coefficient of friction.
9. Does the ramp direct the users out into a road or a parking lot?	Provide a physical barrier across the ramp with right-angle exits to the vehicular area.
10. Are stairs to be used?	Follow guidelines for riser/tread dimensions, layout and details.
11. Are there elevated walkways on the structure?	Provide correct height guardrail and curb.
12. Is there a likelihood that vandals may damage the light fittings?	Select electric fittings that are resistant to vandalism.
13. Does any part of the structure or its components project into the walkway below the head level?	Modify design details to the projection or provide a 7 ft. (2.13 m) clearance.

D. Construction

Designing a structure with adequate accessibility may not insure access. There must also be a clear understanding of the needs of elderly and handicapped pedestrians on the part of the construction supervisory staff. Joint smoothness and width, transitions between ramps and sidewalks or streets, and walkway surfaces can become obstacles unless proper controls are exercised during construction.

III. Design Details

A. End Connection, Approach and Structure Walkways

1. Walkway Widths

The walkway widths within each of the crossing components (structure, approach and end connection) should be designed to accommodate projected pedestrian traffic density; however, the following minimum dimensions should be observed: Minimum clear widths of off structure walks should be 48 in. (1.22 m) to permit wheelchairs and pedestrian traffic to pass (fig. 1). Where minimum walk widths are

used, wheelchair turning and passing areas should occur at approximately 200-foot intervals (fig. 2). For 90-degree turns at T-intersections of walks, a 48-in. (1.22 m) minimum clear width for each branch of the walk should be provided to allow sufficient space for wheelchair turning. Approach and structure walkways should have a minimum width of 96 in. (2.44 m) (Fig. 3).

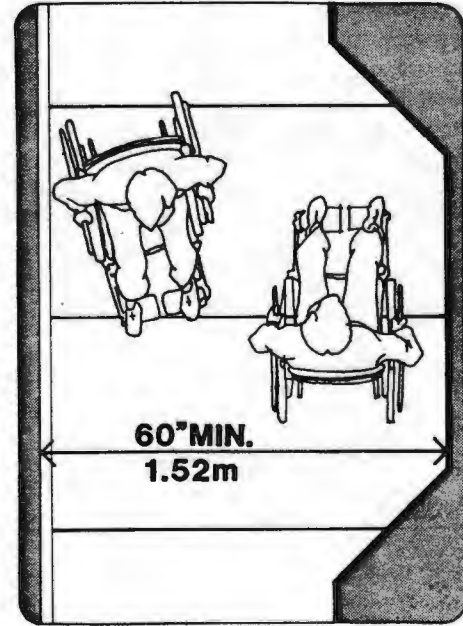

Figure 2. Passing area.

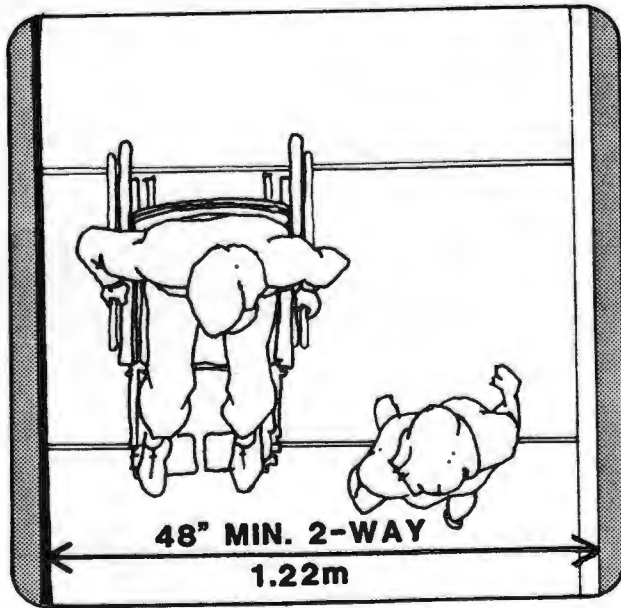

Figure 1. Recommended minimum width for off-structure walks.

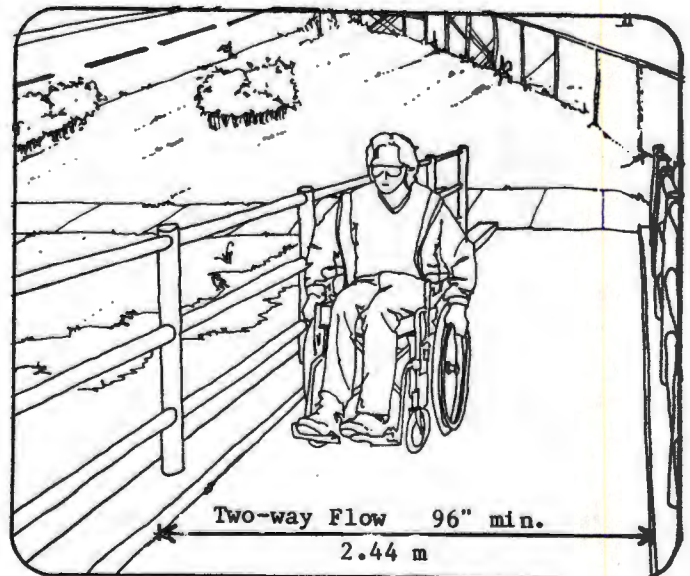

Figure 3. Recommended minimum width for walkways on approaches and structures.

1. Relates to ATBCB Minimum Guidelines and Requirements for Accessible Design Section 1190.50

2. Surfaces

Walkway surfaces should be stable, firm and finished with a relatively smooth but slip-resistant material. Expansion and construction joints should be held to a maximum of 1/2 in. (13 mm) (fig. 4). Avoid joint filler which will expand above the surface. Do not use surfaces constructed from small paving stones which may tend to move independently and cause unevenness. Unsealed gravel, cobblestone, or corrugated textures, are not recommended even as warning or cuing surfaces. Cuing and warning surfaces should have a consistent texture. Joints between adjoining surface materials should be flush, however, a maximum of 1/4 in. (6 mm) vertical height difference is allowed without edge treatment (fig. 5). Changes in level between 1/4 in. (6 mm) and 1/2 in. (13 mm) shall be beveled with a slope no greater than 1:2. Where possible, design walkways without joints.

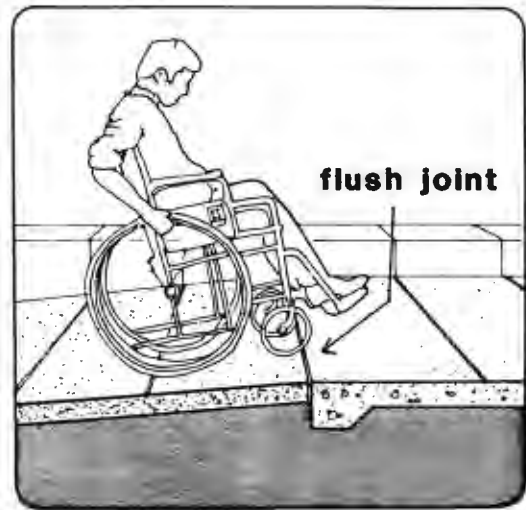

Figure 5. Surface transition to be kept flush.

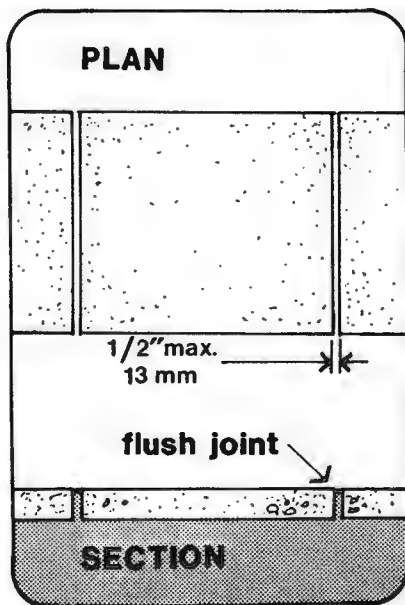

Figure 4. Maximum permissible size of expansion and construction joints.

Where the walk passes an adjacent area (such as a filling station) which is paved with the same, or a similar material, a physical barrier or a textured surface separation between the two areas should be provided (fig. 6). Where physical barriers are used convenient access points should be included. Use walkway surfaces with a low reflectance rating, such as wood, asphalt, composition, or broomed concrete to avoid glare.

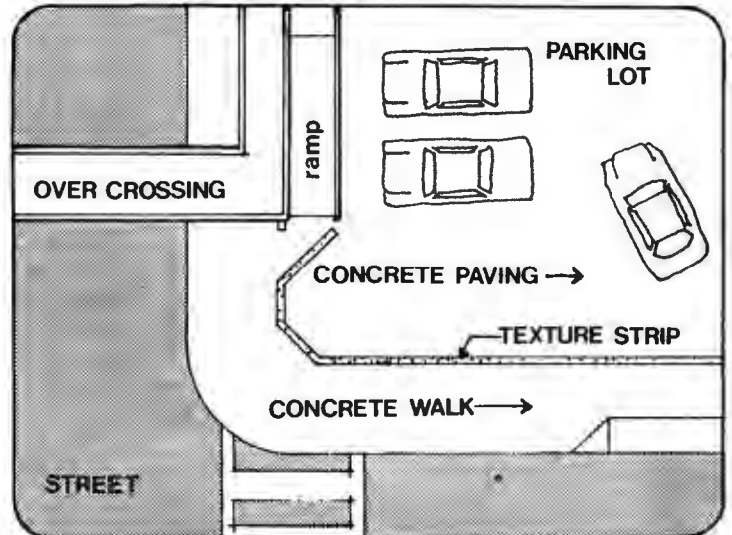

Figure 6. Recommended edges for walkway.

3. Maintenance

Clean sidewalks and walkways frequently to keep them free from trash. Sidewalks and walkways should be cleared of snow and ice immediately after a snowfall. Property owners can be requested to clear walks adjacent to their property. In many jurisdictions local ordinances require this to be done. Culverts and drains should be cleared to avoid flooding of walkways and curb ramps. Appropriate

protective barriers should be provided for blind pedestrians (Fig. 7). Trees planted adjoining walkways should be carefully chosen to minimize debris. Any branches and shrubs overhanging walkways should be cut back or cleared (Fig. 8).

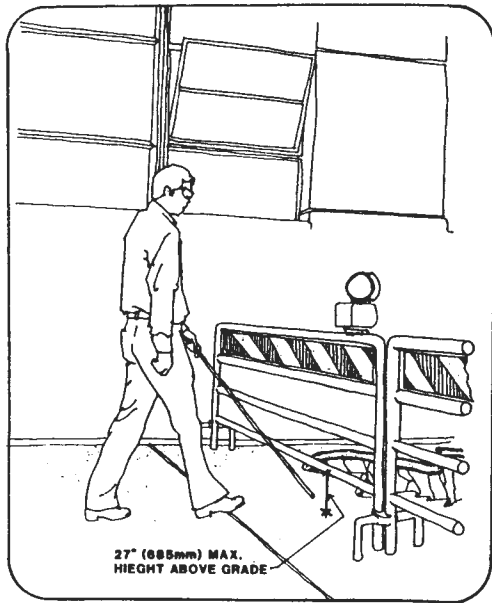

Figure 7. Recommended detectable protective barriers.

4. Gradients

Cross slopes of walks should have a reasonably level cross section. A transverse slope, not greater than 1 in 50 is acceptable (fig. 9). Walks must be graded to avoid depressions or other irregularities. These can cause puddles and icy spots to form. A walk is to be considered a ramp if the gradient exceeds 5 percent (1:20).

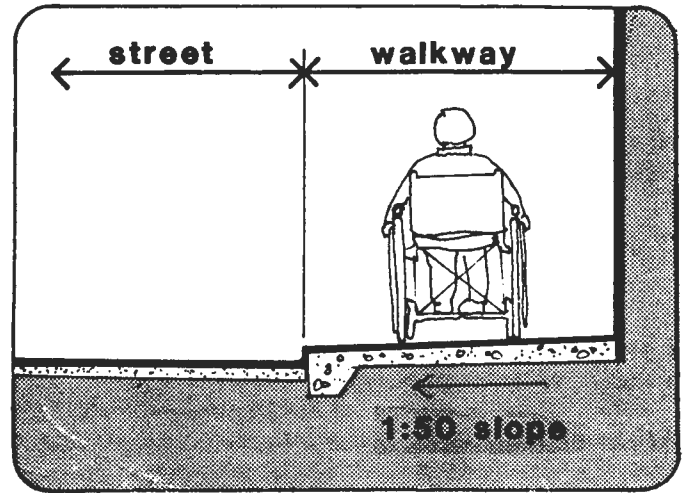

Figure 9. Maximum cross slope for walks.

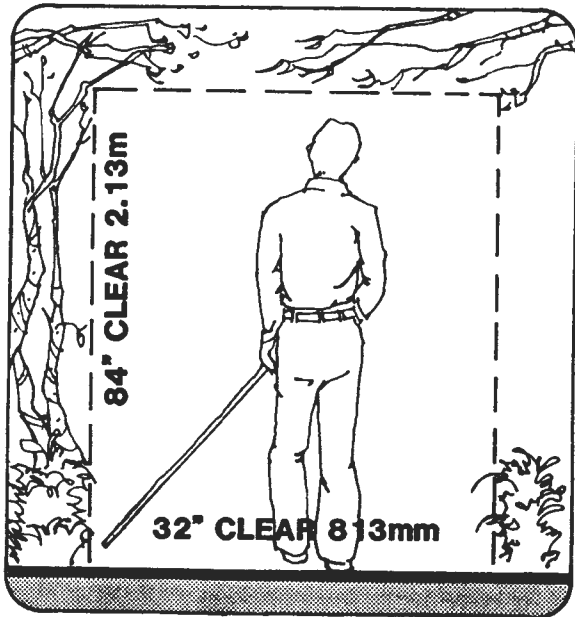

Figure 8. Walkways should be kept clear of overhanging branches and shrubs.

B. Approach Ramps

1. Ramp Lengths and Gradients

The ramp length is determined by the vertical height to be gained. Table 7 gives the maximum allowable ramp gradient for various ranges of vertical height. The overall vertical rise of the ramp determines how many landing areas should be provided. Table 7 also shows distances along the slope where intermediate landings need to be located for the limiting gradients. Ramp surfaces need to be made slip resistant. Required coefficients of friction for various gradients are shown in Figure 12.

1. Relates to ATBCB Minimum Guidelines and Requirements for Accessible Design Section 1190.70

Table 7. Maximum allowable ramp lengths and gradients.

Vertical Rise	Maximum Slope	Landing Number					
		1	2	3	4	5	6
0 to 9 ft. (2.7m)	1:10	45 ft. (13.5m)					
9 ft. (2.7m) to 14 ft. (4.3m)	1:11	69 ft. (20.7m)	124 ft. (37.2m)				
14 ft. (4.3m) to 16 ft. (4.9m)	1:13	83 ft. (24.9m)	148 ft. (44.4m)	192 ft. (57.6m)			
16 ft. (4.9m) to 20 ft. (6.0m)	1:15	96 ft. (28.8m)	170 ft. (51.0m)	215 ft. (64.5m)	245 ft. (73.5m)	275 ft. (82.5m)	305 ft. (91.5m)

2. Ramp Cross Slopes

The cross slope of ramp surfaces should not be greater than 1:50 (fig. 10).

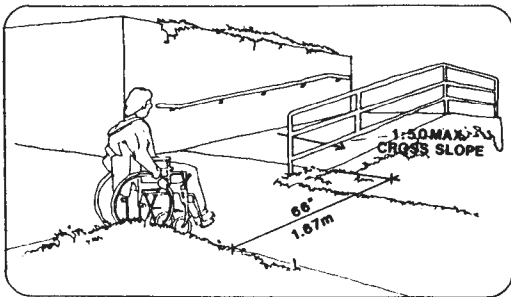

Figure 10. Maximum recommended cross slope of ramp surface.

3. Ramp Landings

Level landings (platforms) should be provided at the top and bottom of each ramp run for starting, stopping, and turning. The minimum clear width of a landing should be equal to the width of the ramp run leading to it. If ramps change direction at landings, a minimum clear width of 60 in. (1.53 m) should be provided. The minimum length of landings and platforms at the top and bottom of ramps should be 66 in. (1.67 m). Figure 11 gives the maximum allowable distances between intermediate landings for various slopes. To use this figure, determine the vertical rise

required for the ramp on the vertical scale, project a line horizontally until it intersects the appropriate sloped lines of the diagram. Select a ramp grade which results in the ramp length and landing position most appropriate. Minimum length of intermediate landings should be 60 in. (1.53 m). Handrails are not required on sloping surface walkways with 5 percent (1:20) or less slope. If a ramp rises more than 6 in. (153 mm) vertically in a single run, or if the horizontal projection of the ramp is greater than 72 in. (1.84 m), then it should have handrails on both sides. Where sidewalks have gradients greater than 5 percent, handrails on the street side may be omitted. Stairs should be considered in addition to ramps where it has been determined persons using crutches or others who have mobility limitations which preclude the use of ramps will regularly use the over- or undercrossing.

C. Approach Stairs

1. Surfaces

Tread surfaces should be slip resistant. Select stair nosing to contrast visually with treads and risers (fig. 12).¹

1. Relates to ATBCB Minimum Guidelines and Requirements for Accessible Design Section 1190.80

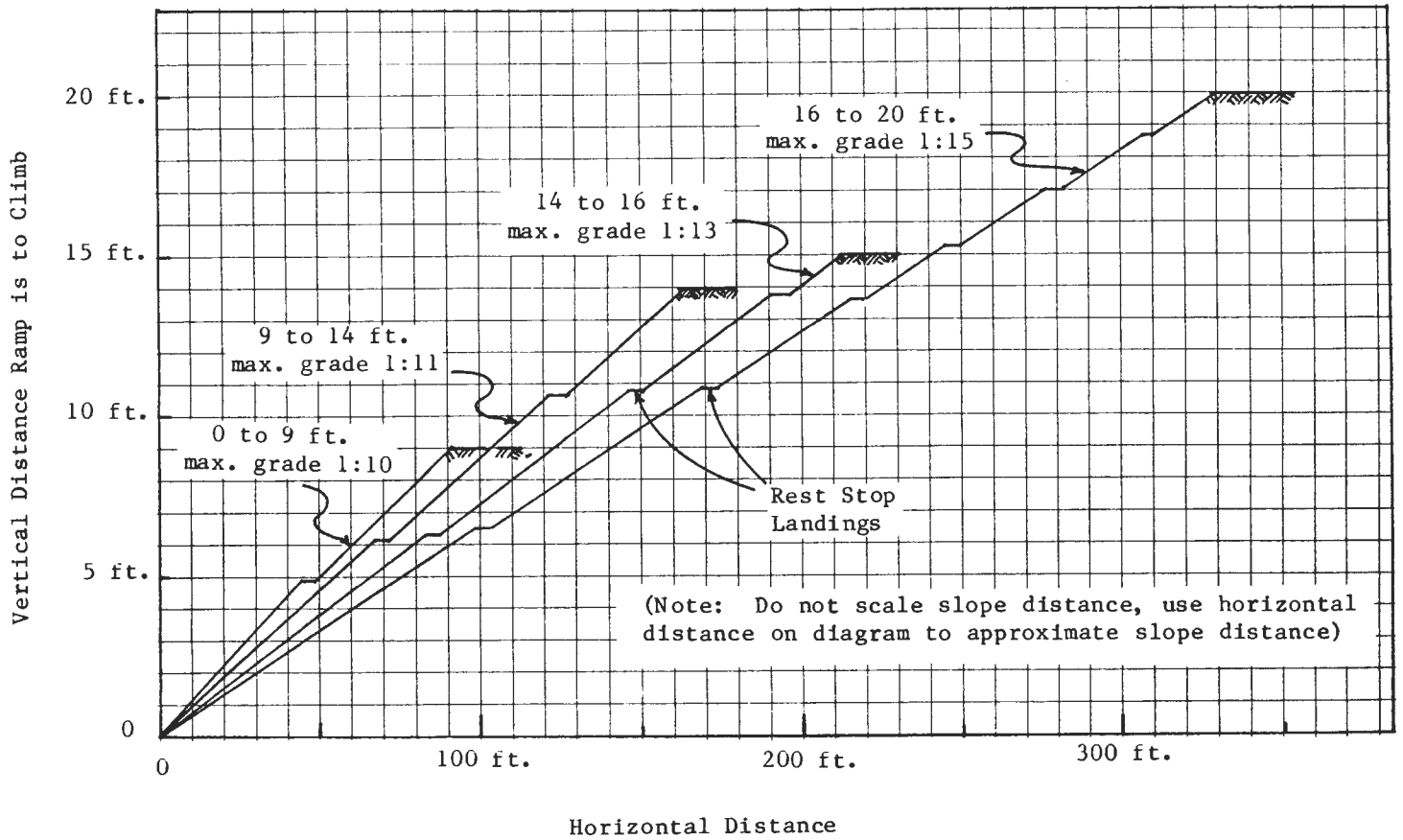

Figure 11. Rest stop landing locations for various ramp grades

Coefficient of Friction Necessary	Gradient						
	Level	1:20 (5%)	1:18 (5.55%)	1:16 (6.25%)	1:14 (7.14%)	1:12 (8.33%)	1:10 (10%)
		Minimum preferred for external surfaces					
	.50	.551	.556	.561	.573	.582	.603
		Minimum acceptable for external surfaces					
	.40	.450	.455	.461	.472	.481	.502
		Minimum acceptable for roofed areas					
	.30	.350	.355	.361	.372	.381	.402

Note: To find a ramp or walkway surface material with adequate slip resistance first find the required coefficient of friction for the gradient to be used from the gradient table above, then select a material whose coefficient of friction matches or exceeds that figure from the list of walkway materials in table 8.

Figure 12. Ramp and walkway slip resistance.

Table 8. Slip resistance: coefficient of friction for selected walkway materials against leather.

Material	Coefficient (dry)
1. Brushed concrete, new, against the brush	.75
2. Asphalt tile, waxed, heavy use area	.56
3. Smooth metal, rusted slightly	.54
4. Asphalt, parking lot, old	.53
5. Checker plate, rusted moderately	.50
6. Quarry tile, unglazed 6 in. x 6 in.	.49
7. Thermoplastic, used, on cross walk	.45
8. Brick pavers, on stair, new, no finish	.43
9. Exposed aggregate, pea gravel, heavy traffic	.41
10. Granite, stairs, old, exterior, well used	.40
11. Plywood "A" side, with grain, no finish	.39
12. Plywood "A" side, against grain, no finish	.38

Table 9. Acceptable tread widths for various riser heights.

Riser Height	Acceptable Tread Widths
7 in. 178 mm	11 in. 280 - 290 mm
6 1/2 in. 165 mm	11 to 12 1/2 in. 280 - 320 mm
6 in. 152 mm	11 to 14 in. 280 - 355 mm
5 1/2 in. 140 mm	11 to 13 in. 280 - 330 mm
5 in. 127 mm	11 to 12 in. 280 - 305 mm

The treads should slope approximately 1/8 in. in 12 in. (1:100) toward the nosing, in order to shed water and to prevent ice formation (fig. 13).

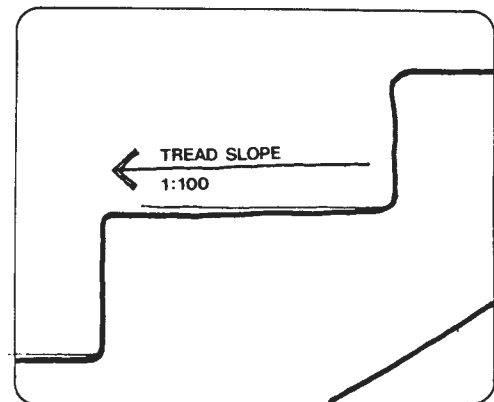

Figure 13. Tread slope.

2. Tactile Warning Markers

A tactile warning marker should be provided where walkways are combined with stairs. Markers used for warnings should be different from markers used to provide guidance cues.

3. Stair Runs

Where fewer than 3 risers in a flight of stairs are required to gain a particular elevation, use a ramp.

4. Treads and Risers

Use uniform tread widths and uniform riser heights for all stairs. Minimum tread depth should be not less than 11 in. (280 mm). The recommended tread-riser relationships are contained in Table 9.

5. Types of Steps

Stair nosing projections should be designed with a smooth curve to avoid catching pedestrians' toes. Steps should not have abrupt (squared) nosings. Non-projecting chamfered nosings, or 1/2 in. maximum radius (12.5 mm) rounded nosings, are preferred.

6. Approach Stair Widths

Stairs used as an approach to a pedestrian over- or undercrossing structure should have a minimum width of 96 in (2.44 m). Tactile strips, when used, should be at least 24 in (.61 m) wide and should extend at least 36 in (.91 m) from the hazard, and be the full width of the hazard (fig. 14).

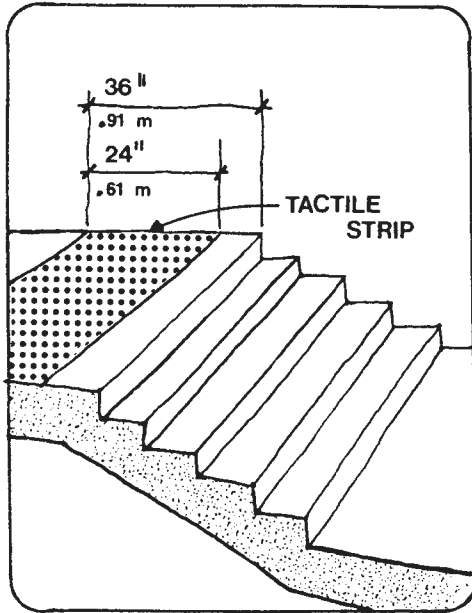

Figure 14. Tactile signal.

7. Hazardous Layouts

No part of a stair should be constructed to overhang a walkway at, or below, head height. Unless the overhang projects 4 in (102 mm) or less into the walkway, the overhang should be at least 84 in (2.13 m) clear above the walkway.

8. Stair Landings

The minimum clear width of landing where stairs reverse direction, should equal the combined widths of connecting stair runs (exclusive of wall or handrail thickness) or 96 in (2.44 m) whichever is greater (fig. 15). The minimum clear depth of landing should equal the width of the widest stair run or 48 in (1.2 m), whichever is larger.

Stairways leading to and from walkways should be set back from the edge of the walkway at least 23 in (.58 m) at the bottom, and 12 in (304 mm) at the top.

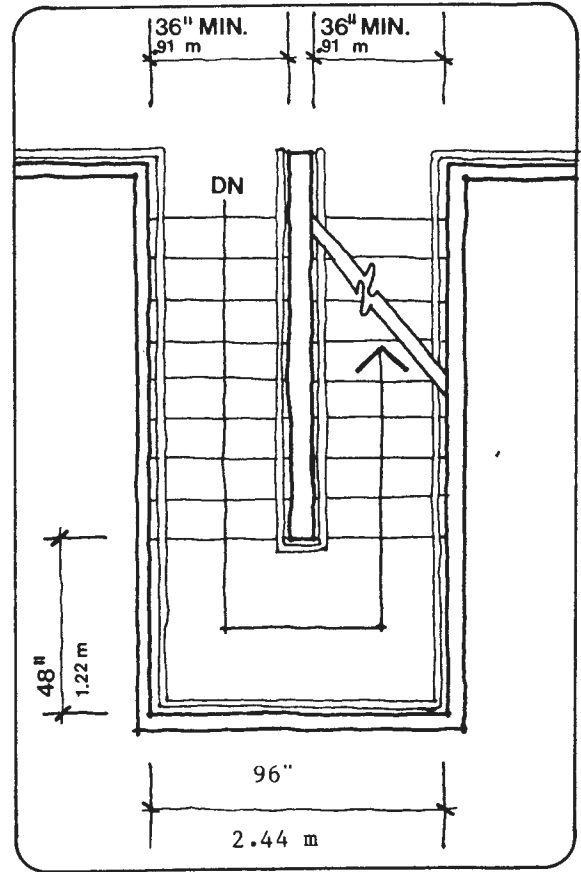

Figure 15. Recommended minimum landing width.

D. Railings and Handrails

1. Rail Heights

Railings are needed on stairs, ramps and at walkway dropoffs of more than 6 in (152.5 mm). Attention should be given to the open sides of platforms, and stair and ramp landings. The height of railings from level surface floors should be 42 in (1.06 m) minimum measured from the top of the rail to the surface of the floor finish (fig. 16).

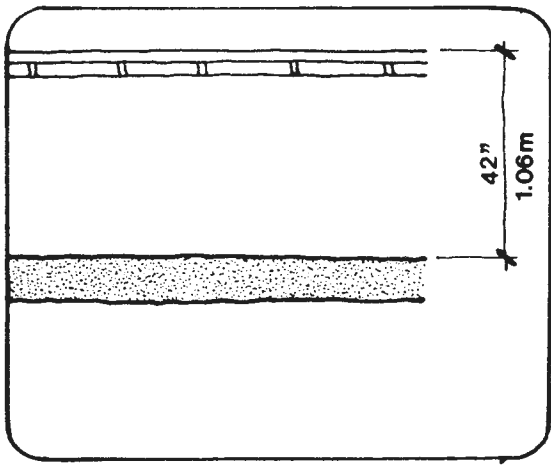

Figure 16. Guardrail height.

Where bicycles will use the facility, railings should be 54 in. (1.37 m) high. The height of handrails on stairs should be 32 in. - 34 in. (.81 m - .87 m) measured from the top of the handrail to the surface of the tread at the nosing (fig. 17). The height of

handrails on ramps should be 32 in. - 34 in. (.81 m - .87 m) measured from the top of the handrail to the surface of the ramp vertically below (fig. 18). The height of stair handrails for children and people of small stature should be 16 in. - 25 in. (.41 m - .64 m) measured from the top of the handrail to the surface of the tread at the nosing (fig. 19).

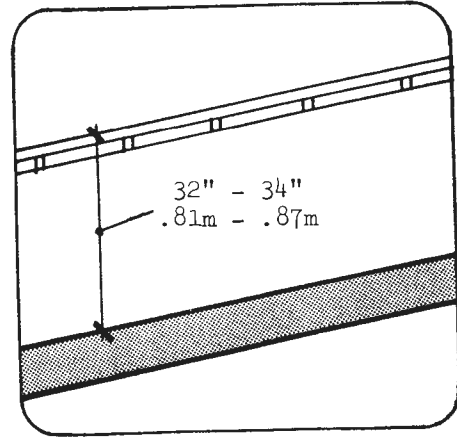

Figure 18. Ramp handrail height.

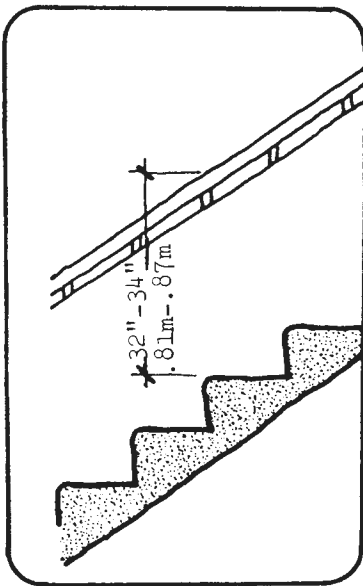

Figure 17. Stair handrail height.

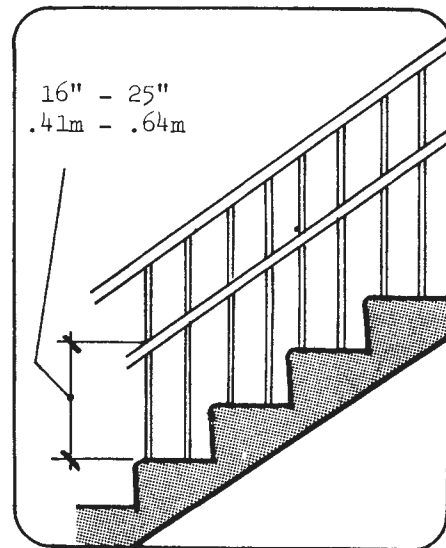

Figure 19. Handrail for children.

2. Handrail Extensions

Handrails should extend horizontally a minimum of 12 in. (305 mm) beyond the top of a stair to provide a cueing and orientation guide to blind pedestrians and to support pedestrians with limited agility while becoming oriented to the level surface. Handrails should extend beyond the bottom riser for a distance equal to the tread width, and then be continued horizontally for 12 in. (305 mm) (fig. 20). Handrails should extend horizontally a minimum of 12 in. (305 mm) beyond the top or bottom of a ramp (fig. 21). No handrails should

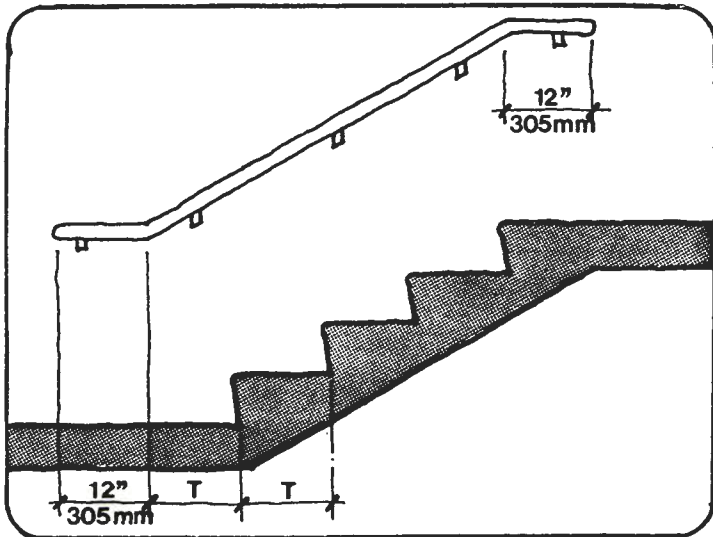

Figure 20. Stair handrail extension.

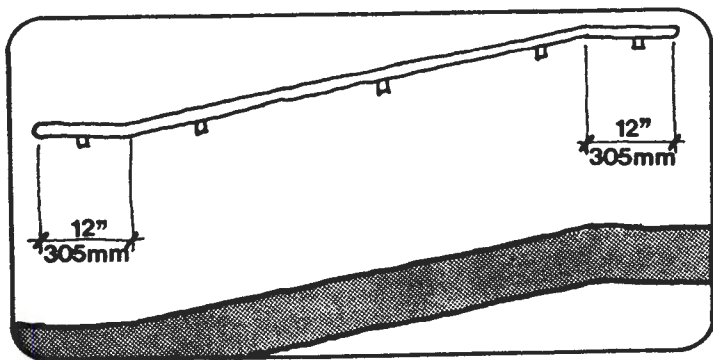

Figure 21. Ramp handrail extension.

project into walkways. The ends should return to the floor or adjoining walls (fig. 22). Handrails to stairs and ramp landings should continue along at least one side of a landing. Handrail section design should allow hands to use a natural grip. On switchback or dogleg stairs or ramps, the inside handrail is to be continuous.

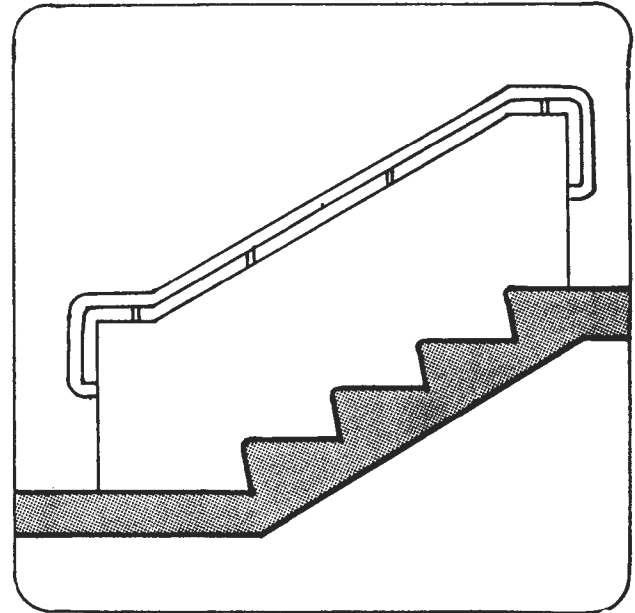

Figure 22. Handrail projection.

3. Handrail Design

Where the handrail section is deeper than 2 in. (51 mm), the upper portion of the section should be shaped so that the hand may grip the rail securely (fig. 23). The width of the section should be no wider than 1 1/2 in. (38 mm). All edges should be chamfered or eased. The gripping surface of continuous handrails should not be interrupted by goosenecks, newel posts, or other construction elements or obstructions. The materials for handrails should be poor conductors of heat, such as wood or plastic. Handrails mounted on a wall should have a minimum of 1 1/2 in. (38 mm) free space between wall and handrail. Supports for handrails should be mounted on a 2-in. (51 mm) minimum high curb. This is to prevent wheelchair wheels from going under the handrail and to provide a continual reference

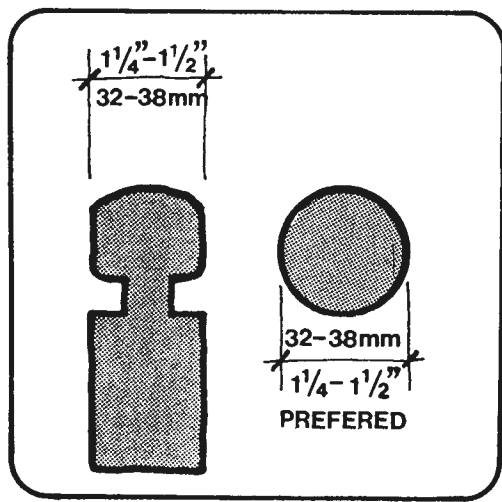

Figure 23. Handrails allowing natural opposing grip.

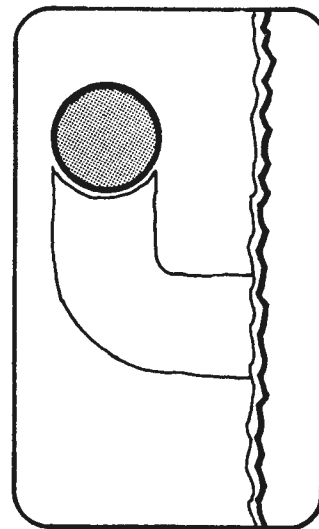

Figure 25. Avoid rough textured finish on wall.

surface for blind cane users. Wall brackets for handrails should be affixed to the underside of rails (figs. 24 and 25). Recessed handrails should not be used (fig. 26).

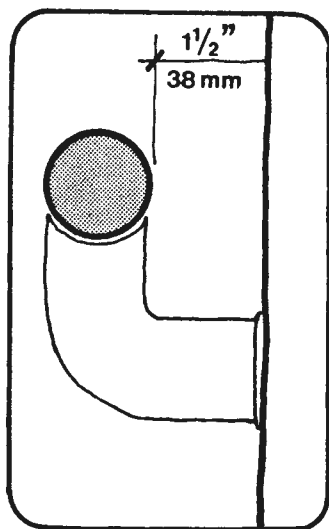

Figure 24. Handrail mounting.

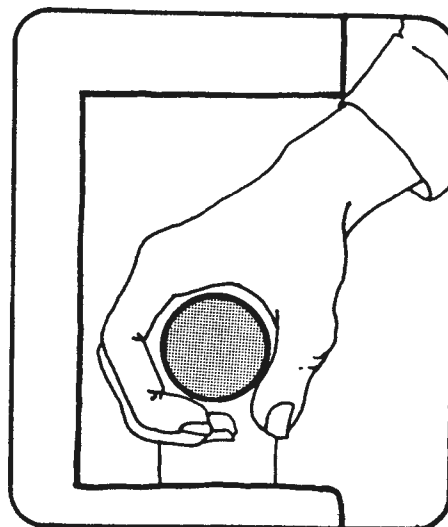

Figure 26. Avoid recessed handrail.

4. Balustrades and Protective Enclosures

Spacing between members (vertical or horizontal) should be less than 4 in. (100 mm) (figs. 27 and 28).

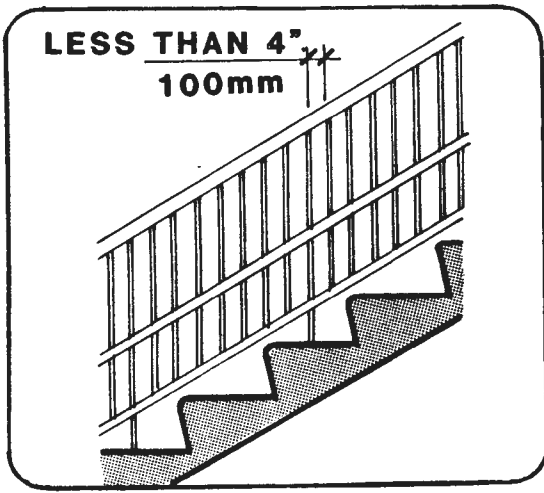

Figure 27. Horizontal handrail member spacing.

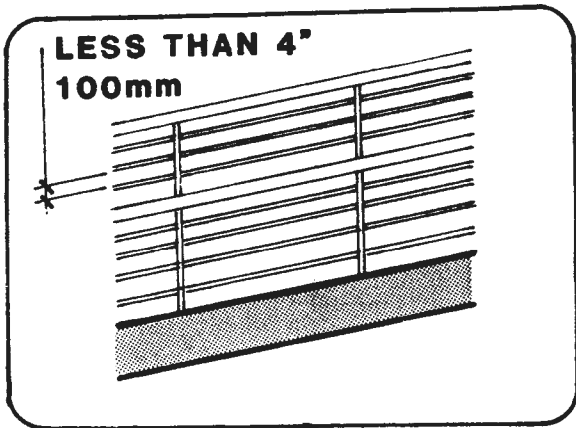

Figure 28. Vertical handrail member spacing.

5. Handrail Load Capacity

All handrails should be designed to withstand bending moments due to a 250-lb. (113 kg.) horizontal concentrated load. Fasteners and mountings of supports should withstand a 250-lb. (113 kg.) shear load and a 250-lb. (113 kg.) tensile load.

E. Pedestrian Barricades

Special pedestrian barricades are desirable where pedestrians are required to pass construction work, where pedestrians are to be restricted from particular areas at special events, or where temporary hazards to pedestrians are located near walkways. These pedestrian barricades generally differ from regular Type I, Type II, and Type III highway traffic barricades (barriers) in size and design, however for some applications highway traffic barriers can be used as pedestrian barricades. The bottom member of pedestrian barricades must be not more than 27 in. (685 mm) from the ground. Barricades should be equipped with both visual and auditory warning devices where possible.

Chain type barriers should be provided with a rigid bar no more than 27 in. above the walkway (figs. 29 and 30). Fencing used as barricades should be free of projections or appendages dangerous to pedestrians on adjacent walkways, playing fields, or other public spaces.

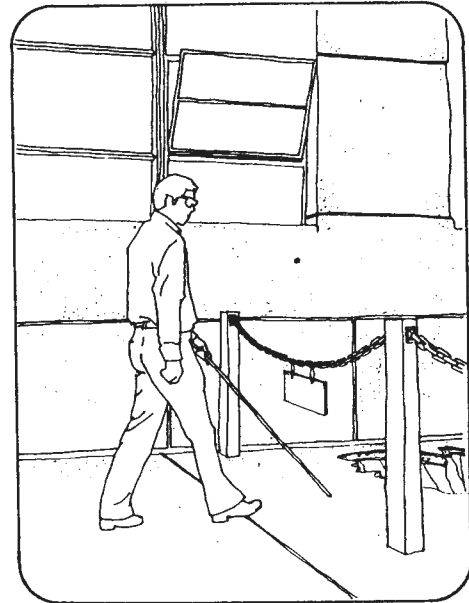

Figure 29. Hazardous barricades.

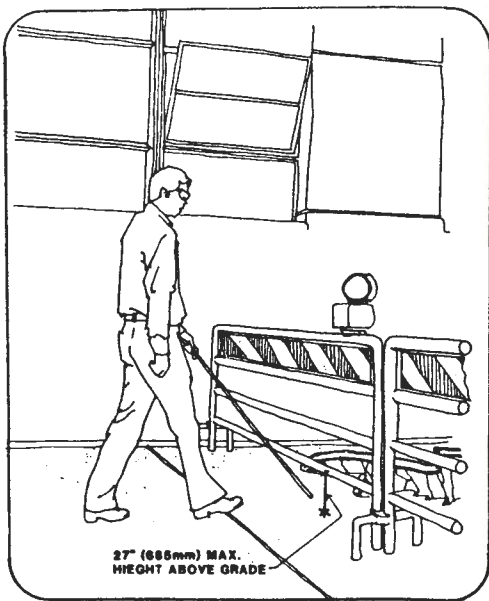

Figure 30. Detectable barricades.

F. Lighting

Where over- or undercrossing structures and approaches will be heavily used, particularly by handicapped pedestrians, lighting levels as recommended by the Illuminating Engineering Society (IES) should be provided. Steps, stairs, and ramps, should be well lighted without inducing glare. The lighting level recommended by the IES for crosswalk illumination is an average illumination level within the crosswalk area of at least 7.0 horizontal footcandles (75 lux). Recommended minimum values for walks are: residential areas, 0.2 footcandles (2 lux); intermediate areas, 0.6 footcandles (6 lux); and commercial areas, 0.9 footcandles (10 lux). In high crime areas, use double the usual recommendation, and never less than 0.5 footcandles (5 lux). Light fixtures should be vandalproof and located to discourage tampering.

G. Signs

1. Location of Signs

Signs should be located within the normal angles of view - from 10 degrees above to 10 degrees below eye level for a standing person (60 to 72 in. (1.52 to 1.83 m)) (fig. 31),

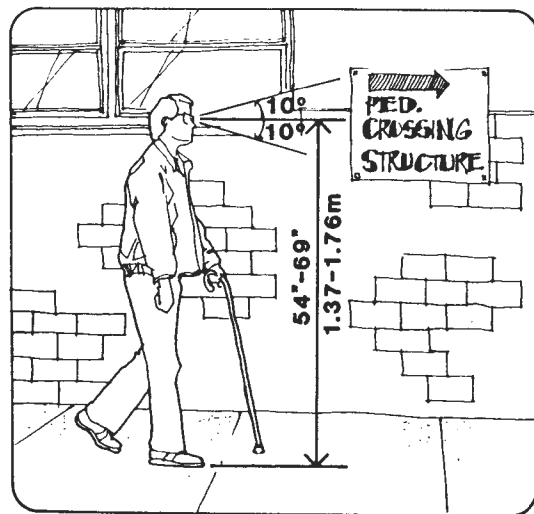

Figure 31. Angle of view for ambulatory individuals.

and from 15 degrees above to 15 degrees below eye level for a seated person (fig. 32). Locate signs at the sidewalk edge at least 40 in. high for wheelchair users and 50 in. high for ambulatory individuals. Avoid locating signs over the sidewalks when the signs are intended for pedestrians. Signs projecting over the walkway require a mounting height of 84 in. (2.13 m) and are usually difficult for handicapped pedestrians to use.

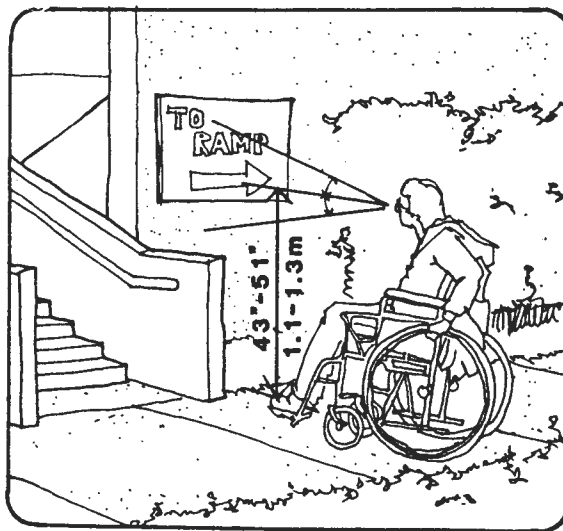

Figure 32. Angle of view for wheelchair bound individuals.

Signage positioned directly facing the path of travel is the most easily visible. Most people can distinguish signage within an angle of 30 degrees to either side of their face, without moving their head (fig. 33). Signs should be located so that they will not become a hazard or an obstacle to the pedestrian.

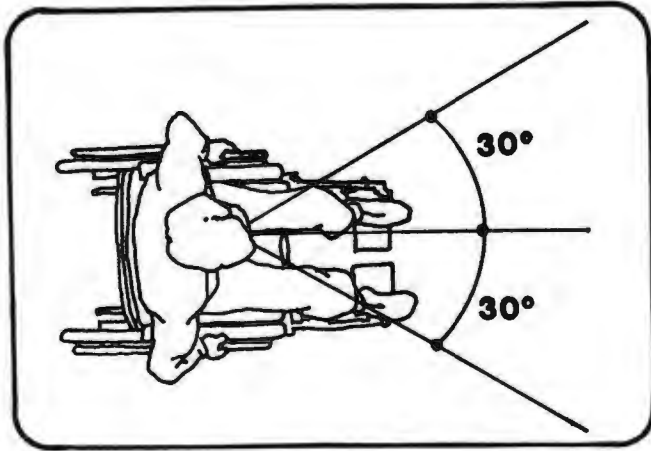

Figure 33. View restricted with limited head movement.

The print style on signs should be simple with raised letters. Lowercase letters with capitals are the easiest for pedestrians with limited eyesight to use. Elaborate styles are more difficult to read. The most critical signs should be reproduced in braille as well as in raised letters. The characters should be raised at least 1/32 in. (.8 mm), the height should be at least 5/8 in. (1.5 mm) (fig. 34).

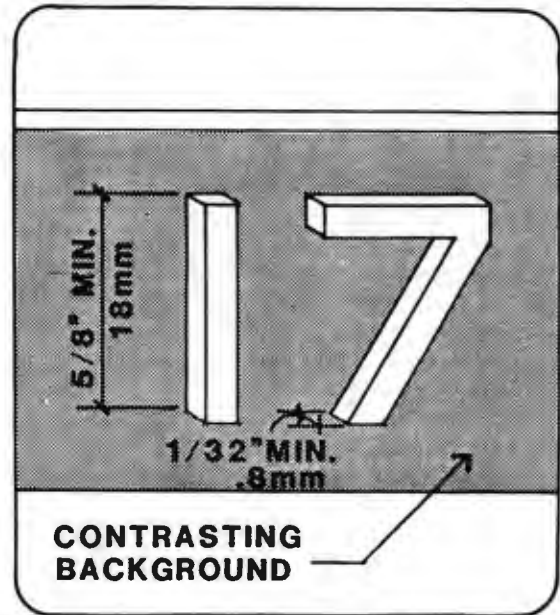

Figure 34. Raised characters detectable to the visually impaired.

2. Sign Legibility

The legibility of signs depends on the distance between the viewer and the sign, the relationship between the height of the characters and the width of the stroke, the color contrast between the characters and the background, the print font, and the illumination. The size of characters must be determined on the basis of the probable viewing distance. The characters on information signs for pedestrians should fall within the following proportions: Stroke width to height 1:5 to 1:10, character width to height 3:5 to 1:1.

It is desirable to provide a contrast between the character color and background. Light colored characters on a dark background are recommended as these are the most legible to the elderly. Sign lamination should be provided for the entire sign panel. In underpasses, where area lighting is generally provided, signs still require special lighting for emphasis. Avoid using recessed ceiling spotlights which tend to produce "pools" of light and distract from sign locations. The overall lighting level should be fairly low in underpasses to avoid glare, however, the daytime illumination level may have to be higher to compensate for the contrast in the underpass with outside illumination levels.

3. Special Signs and Signals for Handicapped Pedestrians

The International Symbol of Accessibility should be displayed at the beginning of accessible paths leading to the crossing structure if other paths are not accessible (fig. 35). If a path is not accessible, a sign should direct people to the nearest accessible route. Tactile guidance cues on walking surfaces can be used to provide information for visually impaired cane users. Tactile warning cues should be used where steps, stairs, or similar abrupt vertical grade changes are located within a walkway and there is a danger that people with impaired vision may not perceive the hazard.



Figure 35. The international symbol of accessibility.

Where curbs, planters, rough surface textures, low walls, curb ramps, etc., form the junction between a walkway and a street, additional cues are not required. Tactile strips, when provided should extend for the full width of the hazard, should be at least 24 in. (.61 m) in depth, and should extend at least 36 in. (.91 m) from the hazard (fig. 36). Linear

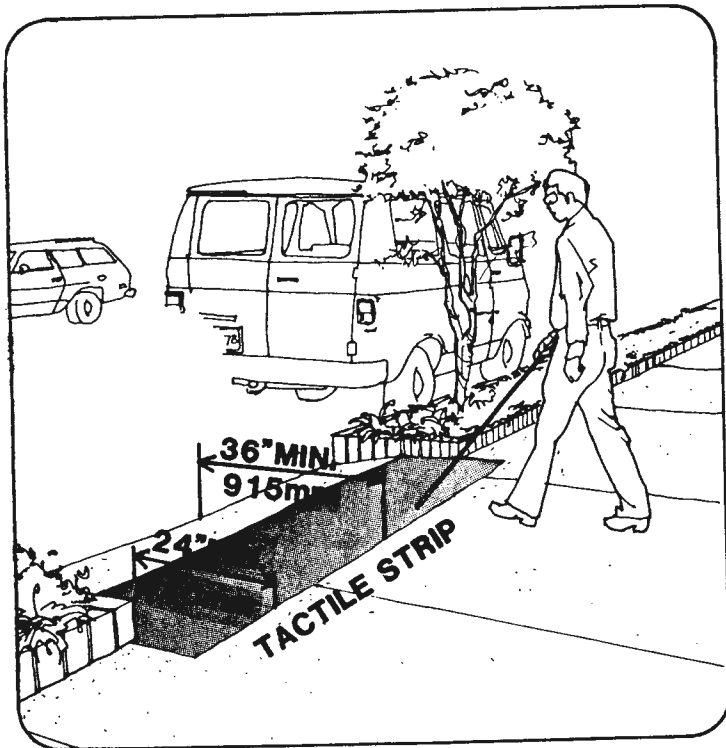

Figure 36. Detectable junction between walkway and street.

tactile strips can be used to define the edge of a walkway as an aid to visually impaired pedestrians. Where pedestrians must cross large open paved areas, paths marked by tactile guidance strips should be provided (fig. 37). A unique material for the walkway which is detectable from the surrounding surface should be used. Where street furniture is located within a strip of sidewalk dedicated for this purpose, it is desirable to add a strip that is detectable by the visually impaired (figs. 38 and 39).

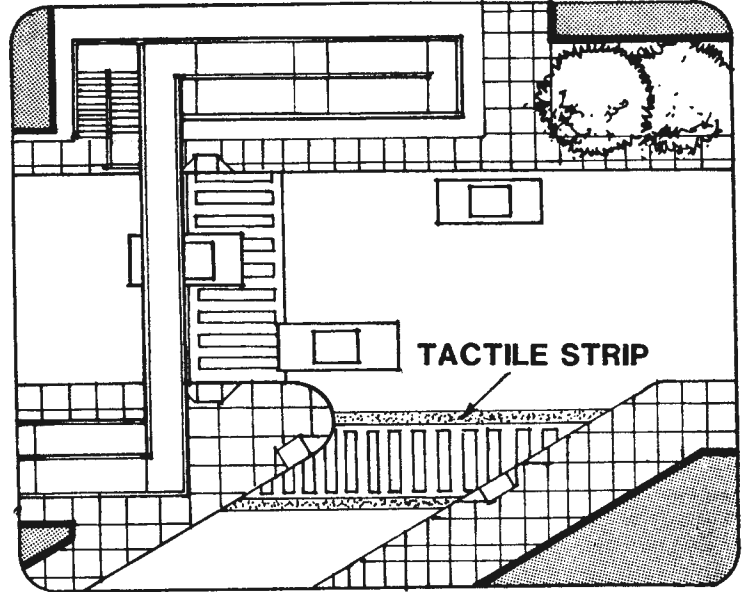

Figure 37. Detectable crosswalk markings.

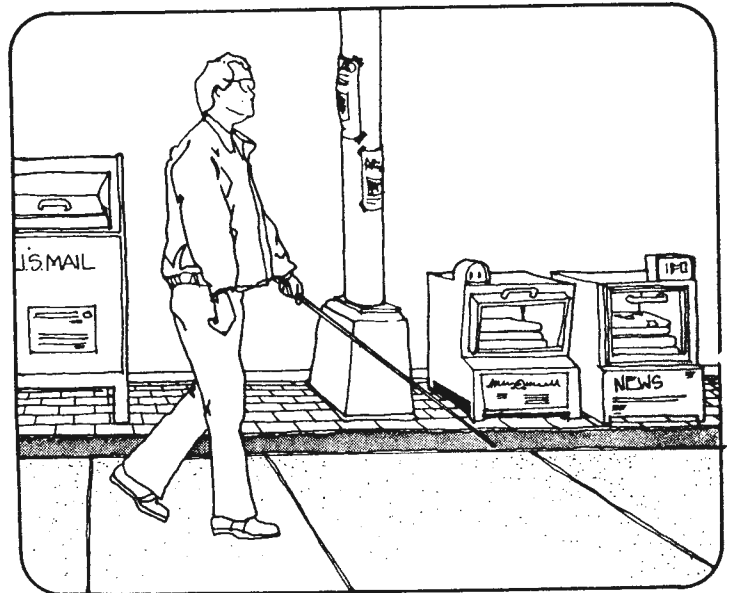

Figure 38. Street furniture strip.

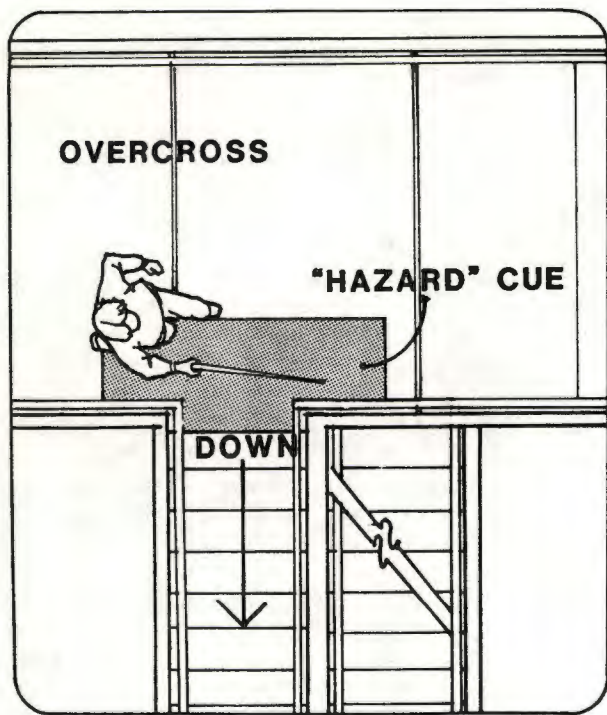

Figure 39. "Checkered" metal plate as a landmark warning of adjacent stairs.

4. Tactile Area Layouts for Blind Pedestrians

Crossing area layouts (tactile maps) of the area of over- or undercrossings can be designed to assist visually impaired persons in locating the boundaries of crosswalks, perceiving the direction of crosswalks, and in reducing ambiguities. If possible, structures should be located so as to provide an obvious path between the pedestrian approach route and the structure. Cane-detectable shorelines or pathways should be provided to help provide a distinct route to the crossing structure (figs. 41 and 42).

Where possible, approach paths should turn off main pedestrian routes using right angle turns, and should be paved. Where possible landmarks should be provided at major turns (fig. 42). On complex pedestrian pathway networks where frequent use by visually impaired people is anticipated, such as near a school, a tactile map should be provided to describe the site in raised figures and symbols. Maps of this type may be produced on a Thermoform-type device and issued as a portable map or may be permanently mounted at

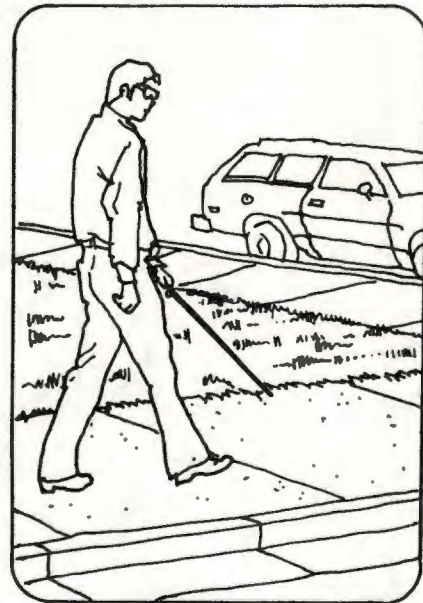

Figure 40. Grass area as a shoreline device.

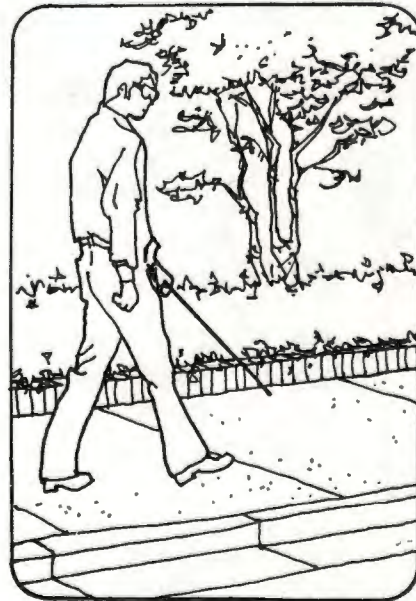

Figure 41. Planter used as a shoreline device.

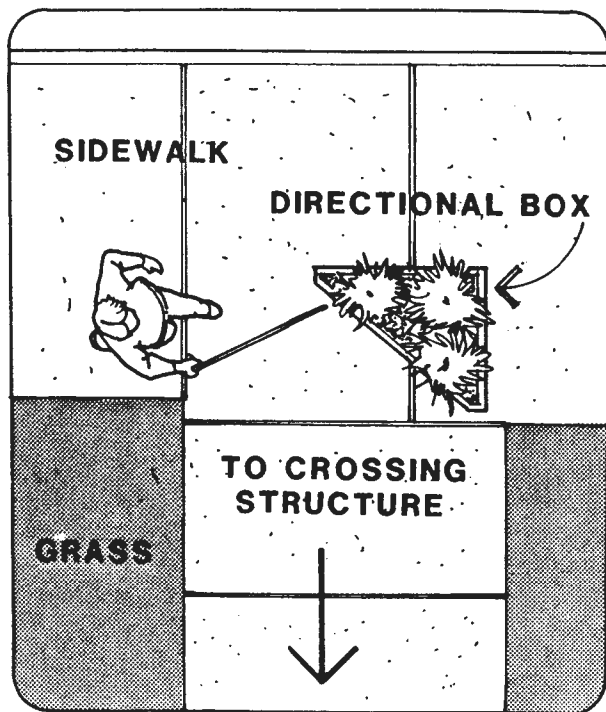

Figure 42. Directional box (planter) used as a landmark and directional aid.

the site. A location to the right of the approach and at a comfortable height (perhaps 30 in. to 48 in. (.76 m to 1.2 m)) is suggested. Since no standard symbols have yet been established for tactile maps, they should be developed by a professional mobility and orientation specialist.

IV. Definitions

Accessible - The condition of a pedestrian facility which allows efficient use by pedestrians with disabling characteristics.

Approach - A component of a pedestrian over- or undercrossing within a route. The portion between the "end connection" and the "structure."

Barricade - An element placed at a dangerous location to prevent pedestrians from encountering the danger.

Barrier - Any "element" of a pedestrian facility which blocks, hinders, or fails to provide a needed service. "Barrier-Free," means a facility is at an acceptable level as far as movement of elderly and handicapped pedestrians is concerned.

Component - Major segments of a pedestrian route. Sidewalk segments per block face, street crossings, end connections, approaches, and structures are considered components.

Countermeasure - The treatment or the feature which is provided to remove a "barrier."

Districts - Major areas within a city that possess similar travel demands from the elderly and handicapped. They may be defined by city administrations for other purposes.

Element - The smallest unit within the route, and it consists of curbs, walkway surfaces, ramps, or stairs. Each element is susceptible to improvement through the application of "countermeasures."

End connection - The terminal area of an over- or undercrossing. It may be defined as a crossing component at a signalized intersection or it may be a sidewalk segment leading to the base of an over- or undercrossing ramp.

Footcandle (lux) - The unit of measurement for the amount of illumination falling on a surface.

Handrails - Elements placed on stairs and ramps to provide continuous support and to aid pedestrians in ascending or descending.

Lumen - The unit of measurement for the amount of light energy given off by a light source.

Mobility - A status of disabled pedestrians which lets them travel with relative freedom and efficiency. It requires that both orientation and accessibility be present.

Orientation - A status of the blind which allows them to move in a desired direction of travel with adequate knowledge of the component elements and countermeasures to be encountered.

Priority Accessible Networks (PAN) - A system of routes for use by elderly and handicapped pedestrians which have been made accessible using a prioritized improvement process.

Railing - An element similar to a handrail which functions as a barricade.

Ramp - Any part of a constructed pedestrian circulation surface with a slope greater than 5 percent.

Rise - The vertical distance height of a flight of steps.