

**URBAN PUBLIC
TRANSPORTATION**

GLOSSARY

**TRANSPORTATION RESEARCH BOARD
NATIONAL RESEARCH COUNCIL**

HE
141
.U74
1989

1989 TRANSPORTATION RESEARCH BOARD EXECUTIVE COMMITTEE

Officers

Chairman

LOUIS J. GAMBACCINI, General Manager, Southeastern Pennsylvania Transportation Authority (SEPTA), Philadelphia

Vice Chairman

WAYNE MURI, Chief Engineer, Missouri Highway and Transportation Department, Jefferson City

Executive Director

THOMAS B. DEEN, Transportation Research Board

Members

ALFRED A. DELLIBOVI, Administrator, Urban Mass Transportation Administration, U.S. Department of Transportation (ex officio)

ROBERT E. FARRIS, Administrator, Federal Highway Administration, U.S. Department of Transportation (ex officio)

FRANCIS B. FRANCOIS, Executive Director, American Association of State Highway and Transportation Officials, Washington, D.C. (ex officio)

JOHN GRAY, President, National Asphalt Pavement Association, Riverdale, Maryland (ex officio)

THOMAS H. HANNA, President and Chief Executive Officer, Motor Vehicle Manufacturers Association of the United States, Inc., Detroit, Michigan (ex officio)

LT. GEN. HENRY J. HATCH, Chief of Engineers and Commander, U.S. Army Corps of Engineers, Washington, D.C. (ex officio)

T. ALLAN McARTOR, Administrator, Federal Aviation Administration, U.S. Department of Transportation (ex officio)

DIANE STEED, Administrator, National Highway Traffic Safety Administration, U.S. Department of Transportation (ex officio)

GEORGE H. WAY, JR., Vice President, Research and Test Department, Association of American Railroads, Washington, D.C. (ex officio)

ROBERT J. AARONSON, President, Air Transport Association of America, Washington, D.C.

ROBERT N. BOTHMAN, Director, Oregon Department of Transportation, Salem

J. RON BRINSON, President and Chief Executive Officer, The Port Of New Orleans, Louisiana

L. GARY BYRD, Consultant Engineer, Alexandria, Virginia

JOHN A. CLEMENTS, Vice President, Parsons Brinckerhoff Quade and Douglas, Inc., Boston, Massachusetts (Past Chairman, 1985)

SUSAN C. CRAMPTON, Secretary of Transportation, State of Vermont Agency of Transportation, Montpelier

L. STANLEY CRANE, Suburban Station Building, Philadelphia, Pennsylvania

RANDY DOI, Director, IVHS Systems, Motorola, Inc., Northbrook, Illinois

EARL DOVE, Chairman of the Board, AAA Cooper Transportation, Dothan, Alabama

WILLIAM J. HARRIS, E. B. Snead Distinguished Professor of Transportation and Distinguished Professor of Civil Engineering, Associate Director of Texas Transportation Institute, Texas A&M University System, College Station

LOWELL B. JACKSON, Vice President for Transportation, Greenhorne & O'Mara, Inc., Greenbelt, Maryland (Past Chairman, 1987)

DENMAN K. McNEAR, Vice Chairman, Rio Grande Industries, San Francisco, California

LENO MENGHINI, Superintendent and Chief Engineer, Wyoming Highway Department, Cheyenne

WILLIAM W. MILLAR, Executive Director, Port Authority of Allegheny County, Pittsburgh, Pennsylvania

ROBERT E. PAASWELL, Executive Director, Chicago Transit Authority

RAY D. PETHTEL, Commissioner, Virginia Department of Transportation, Richmond

JAMES P. PITZ, Director, Michigan Department of Transportation, Lansing

HERBERT H. RICHARDSON, Deputy Chancellor and Dean of Engineering, Texas A&M University System, College Station (Past Chairman, 1988)

JOE G. RIDEQUETTE, Executive Director, South Carolina Department of Highways and Public Transportation, Columbia

TED TEDESCO, Vice President, Corporate Affairs, American Airlines, Inc., Dallas/Fort Worth Airport, Texas

CARMEN E. TURNER, General Manager, Washington Metropolitan Area Transit Authority, Washington, D.C.

C. MICHAEL WALTON, Bess Harris Jones Centennial Professor and Chairman, College of Engineering, The University of Texas at Austin

FRANKLIN E. WHITE, Commissioner, New York State Department of Transportation, Albany

JULIAN WOLPERT, Henry G. Bryant Professor of Geography, Public Affairs and Urban Planning, Woodrow Wilson School of Public and International Affairs, Princeton University, Princeton, New Jersey

PAUL ZIA, Distinguished Professor, Department of Civil Engineering, North Carolina State University, Raleigh



**URBAN PUBLIC
TRANSPORTATION**

GLOSSARY

Benita H. Gray, *Editor*

Subcommittee on Urban Public Transportation Terms
Committee on Public Transportation Planning and Development

REFERENCE COPY

Transportation Research Board
National Research Council
Washington, D.C. 1989

11283

Urban Public Transportation Glossary
 Price: \$14.00
 Edited for TRB by Ruth Sochard Pitt

mode
 2 public transit

subject areas
 11 administration
 12 planning
 14 finance
 15 socioeconomics
 54 operations and traffic control

HE
 141
 .U74
 1989

Transportation Research Board publications are available by ordering directly from TRB. They may also be obtained on a regular basis through organizational or individual affiliation with TRB; affiliates or library subscribers are eligible for substantial discounts. For further information, write to the Transportation Research Board, National Research Council, 2101 Constitution Avenue, N.W., Washington, D.C. 20418.

Printed in the United States of America

NOTICE: The project that is the subject of this report was approved by the Governing Board of the National Research Council, whose members are drawn from the councils of the National Academy of Sciences, the National Academy of Engineering, and the Institute of Medicine. The members of the committee responsible for the report were chosen for their special competencies and with regard for appropriate balance.

Library of Congress Cataloging-in-Publication Data

Urban public transportation glossary / Subcommittee on Definitions, Committee on Public Transportation Planning and Development, Transportation Research Board, National Research Council ; editor, Benita H. Gray.
 p. cm.

Rev. and updated ed. of: Glossary of urban public transportation terms. 1978.

ISBN 0-309-04718-8

1. Urban transportation—Dictionaries. 2. Local transit—Dictionaries. 3. Transportation—Dictionaries. I. Gray, Benita H. II. National Research Council (U.S.). Transportation Research Board. Committee on Public Transportation Planning and Development. Subcommittee on Definitions. III. Glossary of urban public transportation terms.

HE141.U74 1989
 388.4'03—dc20

89-9945
 CIP

Sponsorship of the Glossary

Urban Public Transportation Section

Chairman: James C. Echols, Tidewater Transportation District Commission

Committee on Public Transportation Planning and Development

Chairman: Michael A. Kemp, Charles River Associates, Inc.

Vice Chairman: Patricia Van Matre, Los Angeles County

Transportation Commission

Secretary: David R. Miller, Parsons, Brinckerhoff, Quade & Douglas Paul N. Bay, Dick Chapman, Chester E. Colby, John Dockendorf, David J. Forkenbrock, Stephen Gordon, George E. Gray, Brendon Hemily, Nathan L. Jaschik, Hermann Knoflachner, Eugene J. Lessieu, Robert L. Peskin, Patti Post, Gilbert T. Satterly, Jr., George M. Smerk, Samuel L. Zimmerman

Subcommittee on Urban Public Transportation Terms

Chairman: Eugene J. Lessieu

Paul N. Bay, Donn Fichter, Benita H. Gray, Patti Post, James E. Reading, George M. Smerk, Edward Weiner

W. Campbell Graeb, Transportation Research Board staff

Sources Used for Illustrations

- J. H. Armstrong. *The Railroad: What it is, What it Does*. Simmons-Boardman, Omaha, Neb., 1974. (For illustrations on pp. 7, 17, 25, 26, 49, 66, and 73.)
- Q. Brackett, M. Biswas, R. Koppa, and S. H. Lucy. *Monorail Technology Study*. Texas Transportation Institute, Texas A&M University, College Station/Texas State Department of Highways and Public Transportation, February 1983. (For illustration on p. 66.)
- C. Henderson et al. *Future Urban Public Transportation Systems: Descriptions, Evaluations, and Programs*. Urban Transportation Administration, U.S. Department of Housing and Urban Development, n.d. (For illustration on p. 38.)
- G. Kovatch et al. *Transportation Systems Technology: A Twenty-Year Outlook*. Massachusetts Institute of Technology, Cambridge/U.S. Department of Commerce, August 1971. (For illustration on p. 66.)
- Transportation Research Board. *Transportation Research Record 1071*. National Research Council, Washington, D.C., 1986, pp. 34-56. (For illustration on p. 25.)

Introduction

Since the *Glossary of Urban Public Transportation Terms* (Special Report 179) was published in 1978, urban public transportation has increased in complexity, and the number of technical terms associated with it has continued to grow significantly. In many cases, the terminologies for planning and operations have developed separately. In addition, many decision makers are, initially, unfamiliar with the technical aspects of transportation. Also, over time, a number of other fields have been drawn into the decision-making process (e.g., environment, government, social services), involving many people who have little transportation expertise.

The original glossary was designed to organize and, to some degree, standardize the terms used in urban public transportation. Its purpose was not only to assist transit system operators in understanding the analytical language of the urban transportation planners and to aid the planners in understanding the operational language of the operators but also to achieve better communication within each discipline. A more general goal was to have the glossary serve as a basic reference for anyone who was interested or involved in public transportation.

Since 1978, several comprehensive glossaries dealing with various aspects of urban public transportation have been published. Each of these glossaries, however, was devoted to its own particular area of interest or was aimed at a small, specific group of users. Moreover, it has been almost 5 years since the most recent of these glossaries was distributed. As a result, it was felt that a revision and update of Special Report 179 was overdue. The responses to a questionnaire distributed by TRB in 1986 confirmed this premise. The Subcommittee on Urban Public Transportation Terms, part of the Committee on Public Transportation Planning and Development, undertook the 2-year effort to update the glossary.

Development of the Revised Glossary

The terms and definitions in Special Report 179 were divided into fields of interest, and these sections were sent to 110 experts in these fields who had indicated that they were willing to review the glossary. Many suggested revisions, additions, and deletions were received. The subcommittee members reviewed all this material, consulted other sources, and through a modified Delphi process, arrived at a consensus for each definition considered. Final phrasing, in many cases, was left in the hands of the editor. The intent of the reviewers' consensus, however, was always maintained. This glossary represents the best information that was available at the time of publication. Certain policy decisions were made by the subcommittee, as follows.

Content

The glossary was to consist of selected terms that are related to urban public transportation planning and operations and are fundamental to the achievement of better communication. Various terms were excluded, such as most computer programming terms (unless directly related to urban public transportation), most labor relations terms, and all terms exclusively concerned with goods movement. Terms for data required to be reported under Section 15 of the Urban Mass Transportation Act of 1964 were not included, and all included financial terms are general in nature.

Precedence

The selection of the primary term, that is, the term under which a definition is found, was arbitrary. The primary term should not necessarily be given a higher priority than its synonyms. Synonyms either follow the primary term, enclosed in parentheses, or may be found within or at the end of the definition, following the words "also known as."

Standardization

It was not the intent of the subcommittee to establish norms or standards. Instead, the objective was to provide a compilation of correct common usage. Many terms will therefore have more than one definition. The presence of a definition in the glossary does not preclude other equally correct definitions.

Structure of the Glossary

The definitions in this glossary are organized alphabetically by term but are extensively cross referenced. Most primary terms will be found in dictionary order (i.e., letter by letter alphabetization), but some will be found in sets under a primary concept, for example, bus, car, control system, transit system. A few definitions will be found in the definition of a related term. Acronyms and abbreviations are presented at the beginning of each alphabetical section, and their listings supply the defined term that is related to the acronym or abbreviation.

Acknowledgments

Although this glossary was prepared by the Subcommittee on Urban Public Transportation Terms, many people assisted in reviewing and commenting on the several drafts. Review comments were received from individuals associated with transit operating properties, metropolitan planning

2 Introduction

organizations, universities, consulting firms, and federal, state, and local agencies. Their valuable assistance contributed significantly to the accuracy and quality of the glossary. Special acknowledgments must go to Professor Vukan R. Vuchic and to transportation consultants Herbert S. Levinson and George Krambles, who reviewed the final draft submitted to the subcommittee members and whose input is reflected in the final definitions.

Sources

In addition to the sources cited in Special Report 179, the following references were consulted in the preparation of this glossary.

- R. F. Adams. *The Language of the Railroader*. University of Oklahoma Press, Norman, Okla., 1977.
- American Association of State Highway and Transportation Officials. *Transportation Glossary*. Washington, D.C., 1983.
- American Public Transit Association. *Guidelines for Design of Rapid Transit Facilities*. Washington, D.C., 1979.
- American Public Transit Association. *A Glossary of Transit Terminology for Governing Board Members*. Washington, D.C., 1984.
- American Railway Engineering Association. *1986-87 Manual for Railway Engineering (Fixed Properties)*. Washington, D.C., 1987.
- J. H. Armstrong. *The Railroad: What it is, What it Does*. Simmons-Boardman, Omaha, Neb., 1978.
- Association of American Railroads. *Car and Locomotive Cyclopedia of American Practice*, 3rd ed., Simmons-Boardman, New York, 1974.
- Association of Monterey Bay Area Governments. *Acronym Dictionary*. Monterey, Calif., n.d.
- B. J. Berry and F. E. Horton. *Geographic Perspectives on Urban Systems*. Prentice-Hall, Englewood Cliffs, N.J., 1970.
- California Department of Transportation. *Evaluation of Implementing Transit Performance Audits*. Sacramento, Calif., 1984.
- California Department of Transportation. *Transit Performance Audit Guidebook*. Sacramento, Calif., 1982.
- D. M. Considine (ed.). *Van Nostrand's Scientific Encyclopedia*. 6th ed., Van Nostrand, New York, 1983.
- J. W. Dickey. *Metropolitan Transportation Planning*. Hemisphere, Washington, D.C., 1983.
- G. J. Fielding. *Managing Public Transit Strategically*. Jossey-Bass, San Francisco, 1987.
- Fleet Maintenance Consultants, Inc. *Design Criteria for a Satellite Bus Maintenance Facility*. Houston, Tex., n.d.
- G. E. Gray and L. A. Hoel (eds.). *Public Transportation: Planning, Operations and Management*. Prentice-Hall, Englewood Cliffs, N.J., 1979.
- K. Gruber (ed.). *Encyclopedia of Associations, 1987*. 21st ed., Gale Research, Detroit, Mich., 1987.
- P. Hoffman (ed.). *Guide to Public Transportation Terms and Definitions*. Leigh, Scott, & Cleary, Denver, Colo., 1981.
- Institute of Public Administration. *Financing Transit: Alternatives for Local Government*. Washington, D.C., 1979.
- Institute of Transportation Studies. *Part-Time Labor, Work Rules, and Transit Costs*. University of California, Irvine, 1981.
- Institute of Transportation Studies and School of Social Sciences. *Development of Performance Indicators for Transit*. University of California, Irvine, 1977.
- N. D. Lea Transportation Research Corporation. *Dictionary of Public Transit*. Washington, D.C., 1981.
- C. H. Lovelock and C. D. Weinberg. *Marketing for Public and Nonprofit Managers*. John Wiley, New York, 1984.
- M. D. Meyer and E. J. Miller. *Urban Transportation Planning: A Decision-Oriented Approach*. McGraw-Hill, New York, 1984.
- Ohio, Kentucky, Indiana Regional Planning Authority. *Glossary of Transportation Planning Terms*. Cincinnati, Ohio, 1971.
- Railway Age. *Railway Age's Comprehensive Railroad Dictionary*. Simmons-Boardman, Omaha, Neb., 1984.
- H. S. Roberts. *Roberts' Dictionary of Industrial Relations*. 3rd ed., Bureau of National Affairs, Washington, D.C., 1986.
- R. E. Schmidt and M. E. Campbell. *Highway Traffic Estimation*. Eno Foundation, Saugatuck, Conn., 1956.
- Southern California Rapid Transit District. *A Glossary of RTD Transit Jargon*. n.p., n.d.
- P. R. Stopher and A. H. Meyburg. *Urban Transportation Modeling and Planning*. Lexington Books, Lexington, Mass., 1975.
- Transportation Research Board. *Special Report 209: Highway Capacity Manual*. National Research Council, Washington, D.C., 1985.
- U.S. Department of Commerce. *1980 Census of Population and Housing: User's Guide, Part B, Glossary*. Washington, D.C., 1982.
- U.S. Department of Transportation. *Glossary of Transportation Terms for Small Systems*. Cambridge, Mass., n.d.
- U.S. Department of Transportation. *Paratransit Handbook: A Guide to Paratransit Implementation*. Washington, D.C., 1979.
- U.S. Department of Transportation. *National Urban Mass Transportation Statistics, FY 1983, Section 15 Annual Report*. Cambridge, Mass., 1984.
- U.S. Department of Transportation. *A Directory of Urban Public Transportation Service*. Washington, D.C., 1986.
- U.S. Department of Transportation. *The Status of the Nation's Local Mass Transportation: Performance and Conditions*. Washington, D.C., 1987.
- U.S. Department of Transportation. *Urban Mass Transportation Act of 1964, as Amended through February 1988, and Related Laws*. Washington, D.C., 1988.
- V. R. Vuchic. *Urban Transportation Systems and Technology*. Prentice-Hall, Englewood Cliffs, N.J., 1981.

A

AADT—annual average daily traffic; see *traffic, annual average daily*.

AAR—Association of American Railroads; see *organizations, Association of American Railroads*.

AASHTO—American Association of State Highway and Transportation Officials; see *organizations, American Association of State Highway and Transportation Officials*.

AAWDT—annual average weekday traffic; see *traffic, annual average weekday*.

ABA—American Bus Association; see *organizations, American Bus Association*.

ABS—automatic block signal; see *control system, automatic block signal*.

ACV—air cushion vehicle; see *vehicle, air cushion*.

ADB—advanced design bus; see *bus, advanced design*.

ADT—average daily traffic; see *traffic, average daily*.

AE—annual element.

AFC—automatic fare collection; see *fare collection system, automatic*.

AFZ—auto-free zone.

AGT—automated guideway transit; automated guided transit; see *transit system, automated guideway*.

APTA—American Public Transit Association; see *organizations, American Public Transit Association*.

APWA—American Public Works Association; see *organizations, American Public Works Association*.

ARZ—auto-restricted zone.

ATC system—automatic train control system.

ATO—automatic train operation.

ATP—automatic train protection.

ATS—automatic train supervision; automatic train stop system.

ATU—Amalgamated Transit Union; see *union, transit*.

AVL—automatic vehicle location system.

AVM—automatic vehicle monitoring system.

abandonment—1. In public transportation operations, a procedure whereby a carrier ceases operations on all or part of its lines and routes on permission from the appropriate regulatory authorities. 2. With rights-of-way, the relinquishment of the public interest in right-of-way or activity thereon with no intention to reclaim it or use it again for transportation purposes; also known as *vacation*.

absolute block—see *block, absolute*.

absolute permissive block—see *block, absolute permissive*.

abstract choice model—see *model, abstract choice*.

A car—see *car, A*.

acceleration—increase in velocity per unit time; in transit, usually measured in feet per second squared (meters per second squared) or, in the United States, sometimes in miles per hour per second.

access—permission, liberty, or ability to enter, approach, or make use of.

ground (airport ground access)—highways, local streets, guideway systems, and publicly and privately operated transit services linking an airport to the area that it serves.

limited (controlled access)—in transportation, to have entry and exit limited to predetermined points, as with rail rapid transit or freeways.

unlimited—in transportation, to have entry or exit permitted at any point, as with city streets or taxi service.

accessibility—1. A measure of the ability or ease of all people to travel among various origins and destinations. 2. In transportation modeling and planning, the sum of the travel times from one zone to all other zones in a region, weighted by the relative attractiveness of the destination zones involved. 3. In traffic assignment, a measure of the relative access of an area or zone to population, employment opportunities, community services, and utilities.

handicapped (full accessibility)—the extent to which facilities are free of barriers and usable by mobile handicapped people, including wheelchair users.

point—in planning, a measure of the access of a certain point to activities throughout the region.

region—in planning, a measure of the ability of all people in all zones within a certain region to travel to other zones within that same region.

station—a measure of the ability of all people within a defined area to get to a specific transit station.

transit—1. A measure of the availability to all people of travel to and from various origins and destinations by transit. 2. A measure of the ability of all people to get to and from the nearest transit stop or station and their actual origin or destination. 3. In common usage, often used to mean the ability of the physically handicapped to use transit.

zone—in planning, a measure of the ability of all people in a zone to travel to other zones.

accessible transit system—see *transit system, accessible*.

accessible transportation facilities—transportation facilities that are barrier-free, allowing their use by all travelers, including the mobile physically handicapped, elderly, and transportation disadvantaged.

access mode—see *mode, access*.

access road—see *road, access*.

access street—see *street, local access*.

access time—see *time, access*.

Accounting and Reporting Elements—see *Financial Accounting and Reporting Elements*.

action plan (state action plan)—pursuant to the *Code of Federal Regulations* and guidelines by the U.S. Department of Transportation, a description of the statewide organizational arrangements, assignments of responsibility, and decision-making processes to ensure that economic, social, and environmental effects are fully considered along with

the technical issues in the development of multimodal state and regional transportation plans, corridor studies, and any resulting highway projects, so that final decisions are in the best overall public interest.

activity allocation model—see *model, activity allocation*.

activity center—see *major activity center*.

acts—see *legislation*.

address—as related to U.S. Census and other surveys, a geographic location.

adult cash fare—see *fare, adult cash*.

advanced design bus—see *bus, advanced design*.

advisory committee—see *organizations, citizen advisory committee*.

aerial structure—in transportation, any structure other than a culvert that carries a roadway or track or other guideway above an earth or water surface; see also *guide-way, elevated*.

aerial tramway—in passenger transportation, a mode consisting of cabins suspended from a stationary cable and towed by a moving, usually closed-loop, cable; used to overcome steep gradients, deep valleys, or bodies of water.

agencies, federal—see *U.S. Government*.

agency

joint powers—see *joint powers agreement*.

lead—see *lead agency*.

regional planning—see *organizations, regional planning agency*.

responsible—see *responsible agency*.

transit—see *transit district*.

aggregate demand model—see *model, aggregate demand*.

agreement

joint powers—see *joint powers agreement*.

section 13(c)—see *section 13(c) agreement*.

air brake—see *brake, air*; and *brake, automatic air*.

air cushion system—see *transportation system, air cushion*.

air cushion vehicle—see *vehicle, air cushion*.

air pollution—the presence of unwanted material in the air in sufficient amount and under such circumstances as to interfere significantly with human comfort, health, or welfare, or with full use and enjoyment of property.

airport ground access—see *access, ground*.

air quality—see *ambient air quality*.

air rights—the right to the use of air space over property owned by another. Often air rights are granted for buildings or other uses above or below transportation facilities.

algorithm—a prescribed set of well-defined rules or processes for the solution of a problem in a finite number of steps; see also *Moore's algorithm* and *routing and control algorithm*.

alight—to get off or out of a transportation vehicle.

alignment—in transportation, the horizontal and vertical ground plan of a roadway, railroad, transit route, or other facility as it would appear in plan and profile. The alignment

is usually described on the plans by the use of technical data, such as grades, coordinates, bearings, and horizontal and vertical curves.

allocation—an administrative distribution of funds, for example, federal funds among the states; used for funds that do not have legislatively mandated distribution formulas.

cost—see *cost allocation*.

allocation model, activity—see *model, activity allocation*.

all-or-nothing trip assignment—see *trip assignment, all-or-nothing*.

allowance

cost-of-living—see definition of *escalator clause*.

dismissal—see *pay, severance*.

layoff—see *pay, severance*.

allowance time—see *time, allowance*.

allowances—in labor, pay elements (beyond base pay) included in an operator's wages, for example, intervening time, layover time, overtime, pad time, report time, travel time, turn-in time.

allowed time—see *time, allowance*.

all-stop station—see *station, all-stop*.

alternating-current motor—see *motor, alternating-current*.

alternative

do-nothing—see *no-action alternative*.

low-capital—see *transportation system management alternative*.

no-action—see *no-action alternative*.

no-build—see *transportation system management alternative*.

null—see *no-action alternative*.

preferred—see *preferred alternative*.

transportation system management (TSM)—see *transportation system management alternative*.

alternative fuel—see *fuel, alternative*.

alternatives analysis—a detailed study and assessment of the various options available for the purpose of selecting one for implementation. Ideally, all feasible alternatives will be investigated. An alternatives analysis is required if funds are sought from the Urban Mass Transportation Administration for capital-intensive major transportation projects.

Amalgamated Transit Union—see *union, transit*.

ambient air quality—a physical and chemical measure of the concentration of various chemicals in the outside air, usually determined over a specific time period, for example, 5 minutes, 1 hour, or 1 day.

ambulatory handicapped—see *handicapped, ambulatory*.

American Association of State Highway and Transportation Officials—see *organizations, American Association of State Highway and Transportation Officials*.

American Bus Association—see *organizations, American Bus Association*.

American Public Transit Association—see *organizations, American Public Transit Association*.

American Public Works Association—see *organizations, American Public Works Association*.

a.m. peak—see *peak*.

Amtrak—see *U.S. Government, National Railroad Passenger Corporation*.

analysis

alternatives—see *alternatives analysis*.

cost-benefit—see *cost-benefit analysis*.

cost-effectiveness—see *cost-effectiveness analysis*.

demand—see *demand analysis*.

factor—see *factor analysis*.

impact—see *impact analysis*.

market—see *market analysis*.

marketing cost—see *marketing cost analysis*.

regression—see *regression analysis*.

selected link—see *selected link analysis*.

time series—see *time series analysis*.

value—see *value engineering*.

analysis area or unit—see *area, analysis*.

anchor, rail—see *rail anchor*.

A-95—see *Circular A-95*.

annual average daily traffic—see *traffic, annual average daily*.

annual average weekday traffic—see *traffic, annual average weekday*.

annual element—as provided in FHWA-UMTA joint regulations governing transportation programming, a list of those transportation improvement projects contained in an area's Transportation Improvement Program (TIP) that are proposed for implementation in the first year of the TIP and that are submitted to the U.S. Department of Transportation as part of the required planning process.

annual wage plan—see *guaranteed annual wage plan*.

anticreeper—see *rail anchor*.

application

emergency—see *braking, emergency*.

service—see *braking, service*.

area

analysis (*analysis unit*)—any geographic area, such as a zone or a group of zones combined, for the purpose of making an analysis or study.

auto-free—see *auto-free zone*.

auto-restricted—see *auto-restricted zone*.

consolidated metropolitan statistical (*CMSA*)—a metropolitan statistical area that has more than 1 million population and meets other specified requirements, as provided by the U.S. Office of Management and Budget. A CMSA consists of major components recognized as primary metropolitan statistical areas (PMSAs). See also *area, metropolitan statistical*.

coverage—in transit operations, the geographical area that a transit system is considered to serve, normally based on acceptable walking distances (e.g., 1/4 mile, 0.4 km) from loading points. For suburban rail transit that depends on automobile access (park and ride or kiss and

area (*continued*)

ride), coverage may extend several miles. See also *area, service*.

free—a portion of a transportation facility that people are permitted to enter without the payment of a fare.

fringe—the portion of a municipality immediately outside the central business district or the portion of an urban area outside of a central city or cities (urban fringe) that is characterized by a variety of business, industrial, service, and some residential activity.

metropolitan statistical (*MSA*)—as defined and designated by the U.S. Office of Management and Budget, an MSA consists of the central county or counties containing a city or an urbanized area with a population of at least 50,000 and the adjacent or outlying counties that have close economic and social relationships with the central counties, with a total metropolitan population of at least 100,000. An MSA, in contrast to the urbanized area, will therefore correspond to existing political jurisdiction boundaries (i.e., entire counties, except in the six New England states, where the boundaries are in terms of cities and towns). The term was adopted after the 1980 census and replaces standard metropolitan statistical area (SMSA). See also *area, consolidated metropolitan statistical*.

multiple-use—a transportation right-of-way used for other purposes in addition to transportation, for example, as a park; see also *joint-use corridor*.

paid—1. An area that a passenger may enter only after having paid a fare or with proper credentials. 2. The area in a station that is set off by barriers, gates, or other structures to permit ready access to transit only by those who have paid fares or secured passes before entering.

primary metropolitan statistical (*PMSA*)—as provided by the U.S. Office of Management and Budget, a major component of a consolidated metropolitan statistical area.

rural—as defined by the Bureau of the Census, the urban population includes all people living in urbanized areas or in places with 2,500 or more inhabitants located outside urbanized areas. The rural population consists of everyone else. Both urban and rural areas occur inside and outside of metropolitan statistical areas.

service—1. The jurisdiction in which the transit property operates. 2. The geographic region in which a transit system provides service or that a transit system is required to serve. See also *area, coverage*.

standard metropolitan statistical (*SMSA*)—a large population nucleus and the nearby communities that have a high degree of economic and social integration with that nucleus. Each SMSA consisted of one or more entire counties (or county equivalents; in New England, cities and towns) that met specified standards pertaining to population, commuting ties, and metropolitan character. SMSAs were designated by the U.S. Office of Management and Budget. An SMSA included a city or an urbanized area (as defined by the Bureau of the Census) with a population of at least 50,000 and had a total

area (*continued*)

population of at least 100,000 (75,000 in New England). The term SMSA was replaced by metropolitan statistical area (MSA) after the 1980 census.

study—see *area, analysis*.

urbanized (UA)—as defined by the Bureau of the Census, a population concentration of at least 50,000 inhabitants, generally consisting of a central city and the surrounding, closely settled, contiguous territory (*suburbs*). The boundary is based primarily on a population density of 1,000 people/mi² but also includes some less densely settled areas, as well as such areas as industrial parks and railroad yards, if they are within areas of dense urban development. The boundaries of UAs, the specific criteria used to determine UAs, or both may change in subsequent censuses. It should be noted that some publications abbreviate urbanized area *UZA*.

area occupancy—in station and other facility design and in pedestrian movement, the area provided per person.

area sampling—see *sampling, area*.

armature—the part, usually revolving, of an electric motor or generator that includes the main current-carrying winding and in which the electromotive force is induced.

arrangement, attrition—see *attrition arrangement*.

arterial highway—see *highway, arterial*.

arterial service—see *service, arterial*.

arterial street—see *street, arterial*.

articulated bus or articulated trolleybus—an extra-long, high-capacity bus or trolleybus that has the rear body section or sections flexibly but permanently connected to the forward section. The arrangement allows the vehicle to bend in curves and yet have no interior barrier to movement between the two parts. Typically, an articulated bus is 54–60 ft (16–18 m) long and has a passenger seating capacity of 60 to 80.

articulated rail vehicle (articulated car)—1. An extra-long rail vehicle with two or more bodies connected by joint mechanisms that allow bending in curves yet provide a continuous interior. Typically, the vehicle is 56–100 ft (17–33 m) long. It is very common on light rail transit systems but is also found on several rail rapid transit systems. 2. Rapid transit cars with separate bodies that share a common center truck. 3. Rapid transit cars in consist with two trucks on each car and bodies joined so that passengers can walk between the cars.

aspect, signal—see *signal aspect*.

assessment

environmental—see *environmental assessment*.

needs—see *needs assessment*.

assignment, traffic or trip—see *trip assignment*.

assignment sheet—see *sheet, assignment*.

Assistance, Catalog of Federal Domestic—see *Catalog of Federal Domestic Assistance*.

Association of American Railroads—see *organizations, Association of American Railroads*.

assurance, quality—see *quality assurance*.

asymmetrical monorail—see *transit system, monorail*.

asynchronous motor—see *motor, asynchronous*.

asynchronous network control system—see *control system, asynchronous network*.

attitude survey—see *survey, attitude*.

attitudinal data—in transportation studies, data collected, usually by surveys, from individuals concerning their judgments, views, and perceptions of existing and proposed transportation services and other transportation issues; see also *behavioral data*.

attractions, trip—see *trip attractions*.

attributes, service—see *service attributes*.

attrition arrangement—in labor, the policy of relying on voluntary resignations, deaths, and retirements instead of layoffs to reduce the labor force of a company or organization.

audit, performance—see *performance audit*.

augmented block guidance control system—see *control system, augmented block guidance*.

authority

joint powers—see *joint powers agreement*.

transit—see *transit district*.

auto-free zone (AFZ, auto-free area)—an area in which normal automobile traffic is prohibited. Vehicular traffic is restricted to public transit, emergency vehicles, taxicabs, and delivery of goods (the latter usually confined to certain time periods), or some combination thereof.

automated guideway (guided) transit—see *transit system, automated guideway*.

automated highway system—a system designed to automatically control modified conventional automobiles by external electrical signals emitted by sources such as overhead circuits or circuits embedded in the roadway.

automatic air brake—see *brake, automatic air*.

automatic block signal—see *signal, automatic block*.

automatic block signal control system—see *control system, automatic block signal*.

automatic coupler—see *coupler, automatic*.

automatic fare collection—see *fare collection system, automatic*.

automatic progression—1. A labor policy by which pay rate ranges or rates of pay of workers in jobs with established rate ranges are increased automatically at fixed intervals to the maximum rate for the classification. 2. Automatic movement from a trainee pay rate to the pay rate of a job classification or to the minimum level of a rate range. 3. A method by which workers move according to an agreed-on schedule from one pay scale to another automatically in a specified period of time.

automatic signal—see *signal, automatic*.

automatic train control system (ATC system)—1. A system for automatically controlling train movement, enforcing train safety, and directing train operations by computers; see

also *automatic train operation*, *automatic train protection*, and *automatic train supervision*. 2. A trackside system working in conjunction with equipment installed on the train, arranged so that its operation will automatically result in the application of the brakes to stop or control a train's speed at designated restrictions, should the operator not respond. The system usually works in conjunction with cab signals.

automatic train operation (ATO)—the subsystem within automatic train control that performs such functions as speed control, programmed stopping, and (sometimes) door operation.

automatic train protection (ATP)—the subsystem within automatic train control that provides fail-safe protection against collisions, excessive speed, and other hazardous conditions.

automatic train stop system (ATS)—a trackside system that works in conjunction with equipment installed on the electric rail car or locomotive to apply the brakes at designated restrictions or on a dispatcher's signal, should the operator not respond properly.

automatic train supervision (ATS)—the subsystem within automatic train control that monitors trains, adjusts the performance of individual trains to maintain schedules, and provides data for adjusting service to minimize the inconveniences otherwise caused by irregularities.

automatic vehicle location system (AVL)—a system that senses, at intervals, the location of vehicles carrying special electronic equipment that communicates a signal back to a central control facility. AVLs are used for detecting irregularity in service and are often combined with a computer-aided dispatch system.

automatic vehicle monitoring system (AVM)—a system in which electronic equipment on a vehicle sends signals back to a central control facility, locating the vehicle and providing other information about its operations or about its mechanical condition.

automobile or auto occupancy—see *vehicle occupancy*.

automobile service, public—see *transportation system, public automobile service*.

auto-restricted zone (ARZ, auto-restricted area)—an area in which vehicular traffic is regulated by time of day and type of vehicle. Normal automobile traffic and, sometimes, delivery of goods are limited to certain times; public transit, emergency vehicles, and (usually) taxicabs are permitted unrestricted access.

availability, transit system—see *transit system availability*.

average daily traffic—see *traffic, average daily*.

average earnings—see *earnings, average*.

average fare—see *fare, average*.

average speed—see *velocity, effective*.

axle, tag—see *tag axle*.

B

BOS—bus-only street; see *street, bus-only*.

back, turn—see *turn back*.

✓ **bad order**—1. A notice that a transit unit or locomotive needs repair. 2. A defect in a device or a transit unit or locomotive needing repair.

balanced transportation—see *transportation system, balanced*.

ballast—material placed on a track bed to hold the track in line and elevation and to distribute its load. Suitable material consists of hard particles (e.g., crushed rock, slag, gravel) that are stable, easily tamped, permeable, and resistant to plant growth.

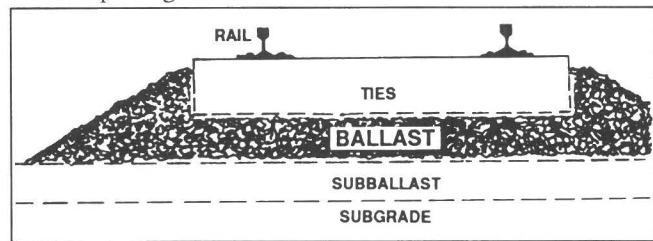

barn—an old-fashioned term for a large storage building for locomotives (also known as a *roundhouse*), rail transit cars (also known as a *carhouse*), or buses (also known as a *garage*).

barrier-free—containing no obstacles that would prevent use by a mobile physically handicapped or any other person.

barrier-free fare collection system—see *fare collection system, self-service barrier-free*.

base, data—see *data base*.

base fare—see *fare, base*.

base headway—see *headway, base*.

base period (off-peak period)—in transit, the time of day during which vehicle requirements and schedules are not influenced by peak-period passenger volume demands (e.g., between morning and afternoon peak periods). At this time, transit riding is fairly constant and usually low to moderate in volume when compared with peak-period travel. See also *off peak*.

base-period fleet—in transit, the number of transit units (vehicles or trains) required to maintain base-period schedules.

base-period service—see *service, base-period*.

base rate—1. The amount of pay for work performed during a unit of time, exclusive of overtime, pay premiums, or incentive earnings. Under incentive systems, the term may refer to the amount paid for an established task at normal work levels. 2. The maximum attainable hourly rate of pay for a designated job classification.

base run—see *run, base*.

base year—1. The year to which the major portion of the data gathered in a transportation survey relates. 2. The first year of a planning or forecast period.

basic fare—see *fare, base*.

basic operating unit—in rail rapid transit, the smallest number of rapid transit vehicles that can operate independently in revenue service, usually one to three (exceptionally more) cars.

battery bus—see *bus, electric*.

bay, bus—see *bus bay*.

B car—see *car, B*.

behavioral data—in transportation studies, data based on the way individuals or coherent groups of individuals, presumably with highly similar responses, behave when faced with a set of transportation alternatives; see also *attitudinal data*.

belt, passenger—see *moving walkway*.

belt highway—see *highway, belt*.

belt system—a means of transportation using continuously moving belts, for example, a pedestrian belt or a belt that carries individual small vehicles.

beltway—see *highway, belt*.

benefit, fringe—see *fringe benefit*.

benefit-cost analysis—see *cost-benefit analysis*.

benefit-cost ratio—the ratio of the dollars of discounted benefits achievable to the given outlay of discounted costs.

berth

bus—see *bus bay*.

train—see *train berth*.

bicycle lane—see *lane, bicycle*.

bicycle route (bicycle way)—any road, street, path, or way that is specifically designated in some manner as being open to bicycle travel, regardless of whether such facilities are designated for the exclusive use of bicycles or are to be shared with other vehicles or pedestrians. See also *lane, bicycle*.

bid—1. To make an offer to secure a contract. 2. To offer a proposal to secure a contract. 3. An employee's request to be assigned a certain piece of work or leave slot. An operator, for example, may bid on a run or days off.

bidder—an individual, partnership, firm, corporation, or any acceptable combination thereof, or joint venture, that is submitting a bid.

bidding runs—see *sign-up*.

bidirectional car—see *car, bidirectional*.

bidirectional transit unit—see *double-ended transit unit*.

bikeway—see *bicycle route*.

bilevel car—see *car, bilevel*.

binary choice model—see *model, binary choice*.

blister—see *bus bay*.

block—1. A section of track or guideway of defined limits on which the movement of trains is governed by block signals, cab signals, or both; also known as a *signal block*. 2. A section of track of defined length, the occupancy of which is regulated by fixed signal(s), telephone or radio orders, or timetables; also known as a *block section*. 3. The daily operating schedule of a transit unit (vehicle or train) between pull-out and pull-in, including scheduled and dead-head service. A block may consist of a number of runs.

block (continued)

absolute—a block that no train may enter while the block is occupied by another train.

absolute permissive—a signal system for a single track or guideway that prevents simultaneous opposing train movements between sidings but permits following movements at a safe distance.

census—see *census block*.

signal—see *block*.

block control system

dynamic—see *control system, moving block*.

fixed—see *control system, fixed block*.

manual—see *control system, manual block*.

moving—see *control system, moving block*.

block grants—aid directed at broadly or functionally defined purposes. In comparison with directed grants, more reliance is placed on state initiative, local initiative, or both in this form of grant.

block guidance control—see *control system, augmented block guidance*.

block indicator—a device, generally located near a turnout switch, that is used to indicate the presence of a train in the block or blocks leading to that switch.

block mileage (block kilometers)—the distance traveled daily during the operating schedule of a transit unit (vehicle or train) from pull-out to pull-in, including scheduled and deadhead service.

block section—see *block*.

block signal—see *signal, block*.

block signal control—see *control system, block signal*; and *control system, automatic block signal*.

board—to go onto or into a transportation vehicle.

extra—see *extra board*.

operators' off-day—see *operators' off-day board*.

paddle—see *paddle board*.

spare—see *extra board*.

body, car—see *car body*.

body-on-chassis—a vehicle that has a body fastened to a chassis usually built for trucks, as is typical in school bus construction; distinguished from integral construction, in which the frame and body are built as one unit.

bogie—see *truck*.

bonded rail joint—see *rail joint, bonded*.

bonus, owl—see *owl bonus*.

bonus time—see *time, allowance*.

book, off—see *off book*.

booked drivers—operating employees who have picked regular runs, including relief runs or trippers.

booking sheet—see *sheet, booking*.

box, fare—see *farebox*.

brake

air—a brake in which the mechanism is actuated by manipulation of air pressure. The term is often used to describe brakes that employ air under pressure above

brake (*continued*)

atmospheric, in contrast to vacuum brakes, which employ pressure below atmospheric.

automatic air—a brake in which air is stored above atmospheric pressure so that a reduction in pressure in the brake line (intentional or by some failure) causes a valve in each rail car to use air from an auxiliary reservoir to build up pressure in the brake cylinder, thus applying the brakes.

continuous (*trainlined brake*)—a system of brakes interconnected among rail cars so that the brakes on all cars in the train can be operated simultaneously from the locomotive or from any car in a multiple-unit train.

disc—a brake used primarily on rail passenger cars that uses brake shoes clamped by calipers against flat steel discs.

dynamic (*electric brake, electrodynamic brake, motor brake*)—a system of electrical braking in which the traction motors, used as generators, retard the vehicle by converting its kinetic energy into electrical energy. This energy is absorbed by suitable resistors. See also *brake, regenerative*. Dynamic brakes may be used to control train speed and to brake a train to a low speed, after which air brakes may bring the train to a full stop.

electric or electrodynamic—see *brake, dynamic*.

electromagnetic—see *brake, track*.

electropneumatic (*pneumatic brake*)—an automatic air brake that has electrically controlled valves to expedite applying and releasing the brakes.

friction (*mechanical brake*)—a brake that presses brake shoes against the running wheel tread or pads against inboard or outboard disc surfaces.

magnetic—see *brake, track*.

mechanical—see *brake, friction*.

motor—see *brake, dynamic*.

pneumatic—see *brake, electropneumatic*.

regenerative—a form of dynamic brake in which the electrical energy generated by braking is returned to the power supply line instead of being dissipated in resistors.

service—1. The primary train brake system. 2. The braking rate used for normal deceleration requirements, in contrast to emergency braking, which may provide greater retardation.

track (*electromagnetic brake, magnetic brake*)—a brake that consists of electromagnetic plates suspended above the track rail between the two axles of a truck. When the brake is activated, the plates drop onto the rails and exert braking by using powerful magnetic force that causes friction. The brake cannot be applied gradually and is used for emergency and holding, generally in conjunction with another braking system. This type of brake is required on all light rail vehicles and most streetcars.

trainlined—see *brake, continuous*.

vacuum—a brake released by air pressure that is lower than atmospheric pressure.

brake shoe—the nonrotating portion of a tread or disc brake assembly. The shoe is pressed against the tread, disc, or drum when the brake is applied.

braking

closed-loop—braking under continuous modulation by means of feedback from the train control system.

emergency (*emergency application*)—in rail operations, applying the brakes to stop in the minimum distance possible for the equipment, usually at a higher retardation rate than that obtained with a maximum service brake application. Once the brake application is initiated, it often cannot be released until the train has stopped or a predetermined time has passed.

full service—see *braking, maximum service*.

maximum service (*full service braking*)—in rail operations, a nonemergency brake application that obtains the maximum brake rate that is normally regarded as comfortable for passengers and consistent with the design of the primary brake system.

open-loop—unmodulated braking without feedback control from the train control system.

programmed—automatically controlled braking that causes a train to stop or reduce its speed to a predetermined level at a designated point within a specified range of deviation.

service (*service application*)—in rail operations, retardation produced by the primary train braking system at the maximum rate of retardation regarded as comfortable for repeated use in service stopping.

branch line—see *line, branch*.

break, paid—see *time, intervening*.

broad gauge—see *gauge, broad*.

brokerage, transportation—see *transportation brokerage*.

budgeting, program—see *planning-programming-budgeting system*.

bunching—with transit units, a situation that occurs when passenger demand is high and dwell times at stops are longer than scheduled. Headways become shorter than scheduled, and platoons of transit units (vehicles or trains) develop, with longer intervals between platoons. The same effect (one transit unit caught by the following) can also be caused by lack of protection from general road traffic congestion or by traffic signal timing. Bunching can become cumulative and can result in delay to passengers and unused capacity.

bus—a self-propelled, rubber-tired road vehicle designed to carry a substantial number of passengers (i.e., 10 or more), commonly operated on streets and highways. A bus has enough headroom to allow passengers (unless they are exceptionally tall) to stand upright after entering, and its body can typically accommodate at least 16 adult passenger seats (various legal definitions may differ slightly as to minimum capacity). Propulsion may be by gasoline, diesel fuel, or electric motor.

advanced design (*ADB*)—a prototype bus, originally introduced in the mid-1970s, that incorporates new

bus (*continued*)

styling and design features specified by the Urban Mass Transportation Administration.

articulated—see *articulated bus or articulated trolleybus*.

battery—see *bus, electric*.

charter—see *service, charter bus*.

commuter—see *service, commuter*.

double-decker—a high-capacity bus that has two levels of seating, one over the other, connected by one or two stairways. Total bus height is usually 13–14.5 ft (4–4.4 m), and typical passenger seating capacity ranges from 40 to 80 people.

dual-mode—1. A bus designed to operate both on city streets and on rails or other types of guideway; also known as a *dual-control bus*. 2. Sometimes used to refer to a trolleybus with a diesel or gasoline engine that can operate away from overhead wires; also known as a *dual-powered bus*.

electric (battery bus)—a bus that is propelled by electric motors mounted on the vehicle. The power source, usually a battery or battery pack, is located in the vehicle or on a trailer.

express—see *service, express bus*.

intercity (over-the-road coach)—a large bus with luggage space, used primarily for transportation between cities. It usually has reclining seats and restroom facilities.

local—see *service, local bus*.

motor (motor coach)—a bus that has a self-contained source of motive power, usually a diesel engine.

New Look—generally refers to a bus model manufactured in the United States and Canada between 1959 and 1978. New Look buses have much larger window areas than those of older buses, although these window areas are smaller than those of buses built in other parts of the world during the same period.

owl—see *run, owl*.

school—1. A vehicle operated by a public or private school or by a private contractor for the purpose of transporting children (through grade 12) to and from school or to and from other school-sponsored activities. The vehicle is externally identifiable as a school bus, typically by color (yellow) and lettering that identifies the school or school district served by the vehicle. This definition includes vehicles designed and built as school buses as well as other vehicles, such as vans and station wagons. See also *service, school bus*. 2. A vehicle designed and built as a school bus, typically with body-on-chassis construction. Such a vehicle may be used for other purposes than school bus service (e.g., military or church service).

small—a bus that is less than 20 ft (6 m) long.

standard urban (transit coach, urban transit bus)—a motor bus designed for a maximum number of seated and standing passengers in short ride, frequent stop service.

bus (*continued*)

Typically, it is 33 to 40 ft (10–12 m) long and is self-powered by a diesel engine, although gasoline and propane engines have been used.

subscription—see *service, subscription bus*.

suburban transit (suburban coach)—a motor bus designed primarily for a seated passenger load and longer journey times. It usually has a single front door, more comfortable seats than a standard urban bus, individual reading lights, and special baggage or package facilities.

trolley—see *trolleybus*.

urban transit—see *bus, standard urban*.

bus bay—1. A branch from or widening of a road that permits buses to stop, without obstructing traffic, while laying over or while passengers board and alight. It is designed to allow easy reentry of the bus into the traffic stream; also known as a *blister, bus duckout, bus turnout, or lay-by*. 2. A specially designed or designated location at a transit stop, station, terminal, or transfer center at which a bus stops to allow passengers to board and alight; also known as a *bus dock or bus berth*. 3. A lane for parking or storing buses in a garage facility, often for maintenance purposes.

bus berth—see *bus bay*.

bus dock or duckout—see *bus bay*.

bus gate—1. A bus priority signal control for intersection approaches. Signals located upstream from the intersection stop traffic in regular lanes while the bus lane remains open, allowing buses to proceed to any lane at the intersection signal ahead of other traffic. 2. In some areas, a crossing gate on highway ramps that only opens for buses.

bush—in planning, a collection of all the efficient paths between some origin and all destinations.

business district—see *central business district* and *outlying business district*.

business enterprise—see *disadvantaged business enterprise, minority business enterprise, and women's business enterprise*.

bus lane—see *lane, bus*.

bus mark-up sheet—see *sheet, booking*.

bus mile (bus kilometer)—one bus operated for 1 mile (kilometer).

bus-only street—see *street, bus-only*.

bus platoon—several buses operating together as a convoy, with each bus following the operating characteristics of the one in front.

buspool—a group of people who share the use and cost of bus transportation between designated origins and destinations on a regular basis, for example, daily trips to work.

bus priority lane—see *lane, bus*.

bus priority system—a system of traffic controls in which buses are given special treatment over the general vehicular traffic (e.g., bus priority lanes or preemption of traffic signals).

metered freeway—a means of giving buses preferential access to enter a freeway by restraining the entrance of

bus priority system (*continued*)

other vehicles through the use of ramp metering; see also *freeway, metered*.

bus rapid transit—see *transit system, bus rapid*.

bus run—see *run, bus*.

bus shelter—see *transit shelter*.

bus stop—see *stop, transit*.

bus turnout—see *bus bay*.

busway—a special roadway designed for exclusive use by buses. It may be constructed at, above, or below grade and may be located in separate rights-of-way or within highway corridors.

bypass, queue—see *queue jumper*.

bypass lane—see *queue jumper*.

bypass road—see *road, bypass*.



C&C—command and control system.

CAC—citizen advisory committee; see *organizations, citizen advisory committee*.

CBA—cost-benefit analysis.

CBD—central business district.

CBO—Congressional Budget Office; see *U.S. Government, Congressional Budget Office*.

CEA—cost-effectiveness analysis.

CFR—*Code of Federal Regulations*.

CMSA—consolidated metropolitan statistical area; see *area, consolidated metropolitan statistical*.

COG—council of governments; see *organizations, council of governments*.

COLA—cost-of-living allowance; see definition of *escalator clause*.

CPI—consumer price index.

CSG—Council of State Governments; see *organizations, Council of State Governments*.

CTC—centralized traffic control; see *control system, centralized traffic*.

CWR—continuous welded rail; see *rail, continuous welded*.

cab—1. The space or compartment in a locomotive or a powered rail car containing the operating controls and providing shelter and seats for the engine crew or motor operator. 2. A taxicab.

cab car—see *car, cab*.

cable, jumper—see *jumper cable*.

cable car—see *car, cable*.

cab signal—see *control system, cab signal*.

calibration—1. Reconciliation of an instrument with an established standard. 2. In modeling, the procedure used to

estimate the parameters of a model or to adjust a model to replicate actually measured conditions.

call, road—see *road call*.

cam controller—a device to regulate direction, accelerating, running, and braking of an electric vehicle. Cams on a rotating shaft open or close spring-loaded contacts that make or break electric circuits between the power supply and the traction motors.

capacity

crush (*crush load*)—the maximum feasible passenger capacity of a vehicle, that is, the capacity at which one more passenger cannot enter without causing serious discomfort to the others.

design—1. For highways, the maximum number of vehicles that can pass over a given section of a lane or roadway in one or both directions during a given time period under prevailing environmental (e.g., weather, light), roadway, and traffic conditions. 2. For transit, the maximum number of passengers that can be transported over a given section of a transit line in one direction during a given time period (usually 1 hr) under prevailing traffic conditions and design comfort standards. 3. For vehicles, the total number of spaces or people a vehicle can accommodate.

fleet (*rolling stock capacity*)—the total number of passenger spaces in all vehicles of a transit fleet.

line—the maximum number of spaces that transit units (vehicles or trains) on a line can transport past a fixed point in one direction per unit of time (usually 1 hr) under actual operating conditions; see also *capacity, theoretical line*.

normal vehicle—see *capacity, vehicle*.

rolling stock—see *capacity, fleet*.

seating (*seated capacity*)—the number of passenger seats in a vehicle.

standing—the number of standing passengers that can be accommodated in a vehicle under specified comfort standards, expressed in area per standee.

theoretical line—the maximum number of transit units (vehicles or trains) or spaces that can be carried over a line segment during a given time period with every transit unit operating at the minimum headway that the control system permits. Real operating conditions may reduce this capacity. See also *capacity, line*.

vehicle (*normal vehicle capacity, total vehicle capacity*)—the maximum number of passengers that the vehicle is designed to accommodate comfortably, seated and standing; may sometimes refer to number of seats only.

capacity restraint—see *trip assignment, capacity restraint*.

capital costs—nonrecurring or infrequently recurring costs of long-term assets, such as land, guideways, stations, buildings, and vehicles. These costs often include related expenses, for example, depreciation and property taxes. See also *operating costs*.

capsule transit system—see *transit system, capsule*.

captive rider—see *rider, captive*.

captive transit rider—see *rider, captive transit*.

car—1. A vehicle running on rails, for example, streetcar, rapid transit car, railroad car. 2. An automobile.

A—a powered rail car that shares mechanical and electrical equipment with another car (the B car) with which it is semipermanently coupled, forming a married pair. It has operator's controls at one end only.

articulated—see *articulated rail vehicle*.

B—a powered rail car that shares mechanical and electrical equipment with another car (the A car) with which it is semipermanently coupled, forming a married pair. It has operator's controls at one end only. 2. In a very few systems, a B car is a car in the middle of a train; it does not have a cab.

bidirectional (double-ended)—a powered rail car that has controls at both ends and symmetrically designed sides and ends for operation in either direction.

bilevel—a rail car that has two levels for passenger accommodation. The upper level may extend through the entire length of the car or only over a part of it; this level is sometimes restricted to seated passengers only. Bilevel cars are used principally on commuter rail lines. Double-deck cars and gallery cars are types of bilevel cars.

C—a powered rail car that usually does not have a control cab.

cab—1. A rail car with a driving cab. 2. A passenger-carrying car used in push-pull service and fitted with a cab at one end, to be used to operate the train when the locomotive is pushing; see also *car, commuter rail*.

cable—an individually controlled rail passenger vehicle operating in mixed street traffic and propelled by gripping a continuously moving cable located in an underground slot between the rails. The cable (which can draw many cable cars simultaneously) is powered by a large stationary motor at some central location instead of aboard the vehicle.

commuter rail—a passenger rail car designed for commuter rail services. It usually has many more seats than a conventional long-distance rail passenger car. The car may be hauled by a locomotive, have a self-contained internal combustion engine, or be electrically propelled by power from a third rail or overhead wire. See also *car, cab*.

diesel multiple-unit—see *car, multiple-unit*.

diesel rail—see *car, rail diesel*.

double-deck—a bilevel rail car with a second level that covers the full width of the car but may or may not extend the full length.

dual-powered turboelectric—a commuter railroad car capable of either running on electric power from a third rail or overhead wire or self-propulsion by a generator driven by a gas turbine.

electric multiple-unit—see *car, multiple-unit*.

electric rail—a rail car powered by current from a conduit along the track. The conduit is usually an overhead wire or third rail. See also *car, rectifier electric motor*.

car (continued)

gallery—a bilevel rail car that has seating and access aisles on a second level along each side of an open well. Tickets of passengers on the second level can be inspected or collected from the lower level.

light rail (LRV, light rail vehicle)—a rail vehicle similar to a streetcar. It may be larger, however, and is often articulated. A light rail car is capable of boarding and discharging passengers at either track or car-floor level.

motor—see *car, rail motor*.

multiple-unit (MU)—a powered rail car arranged either for independent operation or for simultaneous operation with other similar cars, when connected to form a train of such cars. It may be designated as *DMU (diesel multiple-unit)* or *EMU (electric multiple-unit)*, depending on the source of power.

PCC (PCC, Presidents' Conference Committee car)—a streetcar first produced in 1935. Its performance and efficiency were significantly improved over those of any streetcar previously built. The PCC car, characterized by (relatively) lightweight construction, smooth and rapid acceleration and deceleration, and soft ride, became the standard for U.S. streetcars for many years. See also *organizations, Presidents' Conference Committee*.

powered—see *car, rail motor*.

rail diesel (RDC, diesel rail car)—a self-powered rail car that usually has two diesel engines and can usually operate in multiple units (diesel multiple-unit car).

rail motor (motor car, powered car, self-powered car, self-propelled car)—a rail car that is propelled by a motor or engine located on the car itself. It can often be operated in multiple units (*multiple-unit car*). Common types are electric (*electric rail car*), which receives current either from a third rail or from an overhead wire, and diesel (*rail diesel car*).

rail rapid transit (rapid transit car, subway car)—a rail car for rapid transit systems. It is bidirectional, usually powered, and equipped with a control cab at one or both ends. It may be designed to operate in single or multiple units. It has two to five double doors per side, designed for fast boarding and alighting from high-level platforms.

rectifier electric motor—a rail car that collects propulsion power from an alternating-current distribution system and converts it to direct current for application to direct current motors by means of rectifying equipment carried by the rail car. The car may be defined by type of rectifier used, for example, *ignitron electric car*.

self-propelled or self-powered—see *car, rail motor*.

single-unit (SU)—a powered rail car, equipped with a control cab at one or both ends, that operates alone.

track—a self-propelled rail car (e.g., burro crane, highway rail car, detector car, weed burner, tie tamper) that is used in maintenance service and that may or may not operate signals or shunt track circuits.

trailer—1. An unpowered rail car operated in trains with powered cars (rapid transit) or towed by locomotives

car (*continued*)

(regional rail). 2. In some rail rapid transit systems, a trailer may be powered; however, it does not have operator's control and thus can only be operated in consists with cars that do.

trolley—1. A local term for a streetcar. 2. Recently, also a local term for a bus with a body simulating that of an old streetcar.

turboelectric—see *car, dual-powered turboelectric*.

unidirectional—a rail car (usually light rail or streetcar) that has doors on one side and an operating cab at only one end so that it must be turned around by separate means at terminals.

urban rail—a light rail, rail rapid transit, or commuter rail car.

car body—in passenger transportation, that portion of a rail car that carries people.

car card—an advertising card used on the interior or exterior of transit vehicles, usually of a standard size to fit permanent holders.

card

car—see *car card*.

run or train—see *paddle board*.

car equivalence, passenger—see *passenger car equivalence*.

car-following control system—see *control system, car-following*.

carhouse—see definition of *barn*.

car operator—see *operator, train*.

carpool—an arrangement in which two or more people share the use, cost, or both of traveling in privately owned automobiles between fixed points on a regular basis; see also *vanpool*.

carpool lane—see *lane, carpool*; and *lane, exclusive carpool*.

carrier—a person or company in the business of transporting passengers or goods.

common—in urban transportation, a company or agency certified by a regulatory body to carry all passengers who fulfill the contract (e.g., pay the required fare). The service is open to the public.

foreign—a term used by a carrier company in making reference to any other carrier.

carriers under contract—see *purchased transportation*.

car stop—see *stop, transit*.

Catalog of Federal Domestic Assistance—a catalog published annually by the U.S. Office of Management and Budget. It presents a comprehensive listing and description of federal assistance programs administered by different federal departments, agencies, commissions, and councils.

categorical exclusion—National Environmental Policy Act of 1969 categories of action that are exempt from preparing an environmental impact statement.

catenary system—that form of electric contact system in which the overhead contact wire is supported from one or

more longitudinal wires or cables (*messengers*), either directly by hangers (*simple catenary*) or by hangers in combination with auxiliary conductors and clamps (*compound catenary*). Attachment of the contact wire to the messenger is made at frequent and uniform intervals to produce a contact surface nearly parallel to the top of the track rails.

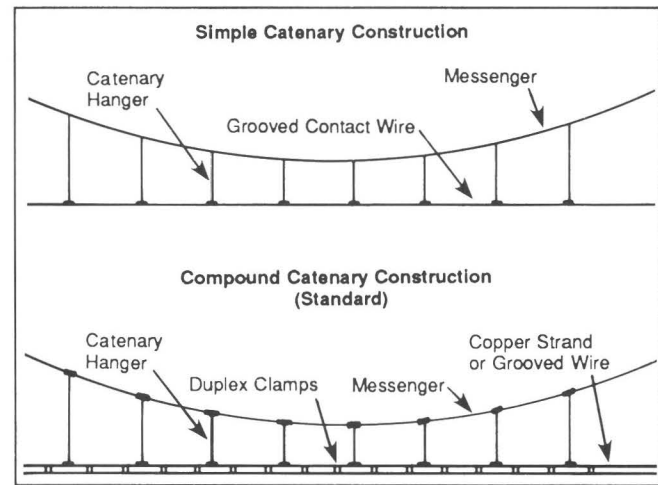

C car—see *car, C*.

census block—as defined by the Bureau of the Census, a geographic area wholly contained within a census tract and bounded on all sides either by streets or by a combination of streets, natural features, waterways, railways, transmission lines, or property lines of public and semipublic tracts. It is the basic unit for tabulation of urban data by the Bureau of the Census.

census enumeration district (ED)—as defined by the Bureau of the Census, an area used for data collection activities and as a tabulation area where census blocks are not present. EDs do not cross boundaries of legal or statistical areas and therefore vary widely in population size. They do not generally exceed 1,600 population in areas where the census is taken by mail or 1,000 where the census is taken by conventional enumerator canvassing.

census tract—as defined by the Bureau of the Census, a small statistical subdivision of a county. Generally, tracts have stable boundaries and 2,500–8,000 residents. When census tracts are established, they are designed to be relatively homogeneous areas in population characteristics, economic status, and living conditions.

center

major activity—see *major activity center*.

modal interchange—see *transit center*.

transfer or transit—see *transit center*.

center platform—see *platform, center*.

central business district (CBD)—as defined by the Bureau of the Census, an area of high land valuation characterized by a high concentration of retail businesses, service businesses, offices, hotels, and theaters, as well as by a high traffic flow. A CBD follows census tract boundaries; that is, it consists of one or more whole census tracts. CBDs are identified only in central cities of MSAs and other cities

with populations of 50,000 or more. See also *outlying business district*.

central city—as defined by the Bureau of the Census, the largest city, or one of the largest cities, in a metropolitan statistical area or urbanized area. The criteria for designating a central city vary with the type of area and the particular census.

centralized traffic control system—see *control system, centralized traffic*.

centroid—in planning, a point within a traffic zone or district that is chosen to be representative of the center of trip-making activities of the zone or district.

certification—in planning, approval by the Federal Highway Administration and the Urban Mass Transportation Administration of a local transportation planning process for compliance with legislative and regulatory requirements; see also *self-certification*.

charge, flag drop—see *flag drop charge*.

charter bus service—see *service, charter bus*.

charter service—see *service, charter*.

charter service revenue—see *revenue, charter service*.

check—in transit operations, a record of the passenger volume on all transit units that pass a specific location or time point (also known as a *passenger riding count or check*), the actual time the unit passes it (also known as a *schedule check*), the number of passengers who board and alight at each stop on a route or line (also known as an *on-and-off count or check*), or any combination of these items. The checker may ride the transit unit (an *on-board check*), follow it in another vehicle, or check the transit units from a particular location (a *point or corner check*).

checker—in transit operations, a person who observes and records passenger counts, timing, speeds, vehicle counts, schedule adherence, or other data useful in transit planning and scheduling. The position may be further specified as *schedule checker, traffic checker*, and so on.

check ride—in transit operations, a ride on which an observer checks the operator's skills, abilities, and compliance with rules and standard operating procedures.

choice rider—see *rider, choice*.

chopper—a solid-state electronic device that controls electric current flow to traction motors by very rapidly turning the power on and off, resulting in gradual vehicle acceleration at reduced current use.

circuit

electric train line—see *electric train line circuit*.

track—see *track circuit*.

Circular A-95—a circular from the U.S. Office of Management and Budget that furnished guidance to federal agencies for cooperation with state and local governments in the evaluation, review, and coordination of federal assistance programs and projects. This procedure has been replaced by the Intergovernmental Review Process (Executive Order 12372, issued July 14, 1982).

circulator service—see *service, circulator*.

citizen advisory committee—see *organizations, citizen advisory committee*.

city, central—see *central city*.

city transit service—see *service, city transit*.

civil speed limit—in rail operations, the maximum speed authorized for each section of track, as determined primarily by the alignment, profile, and structure.

clause, escalator—see *escalator clause*.

closed-loop braking—see *braking, closed-loop*.

coach

motor—see *bus, motor*.

over-the-road—see *bus, intercity*.

suburban—see *bus, suburban transit*.

transit—see *bus, standard urban*.

trolley—see *trolleybus*.

coasting—see *freewheeling*.

Code of Federal Regulations (CFR)—an annual publication that contains all federal regulations currently in effect.

coding, network—see *network coding*.

coefficient

riding frequency or habit—see *riding frequency coefficient*.

utilization—see definition of *load factor*.

coefficient of directness—1. The ratio of the length (measured in units of either distance or time) of a transit trip between two points and the length of the most direct highway route between the two points. 2. The ratio of the length (measured in units of either distance or time) of a trip between two points by one mode and the length of the trip by another mode.

cog railway (rack railway)—a rail transportation mode with auxiliary or full traction provided by a geared wheel in the middle of a powered axle that is engaged with a rack (toothed bar) installed along the track center. This system is used to overcome steep gradients.

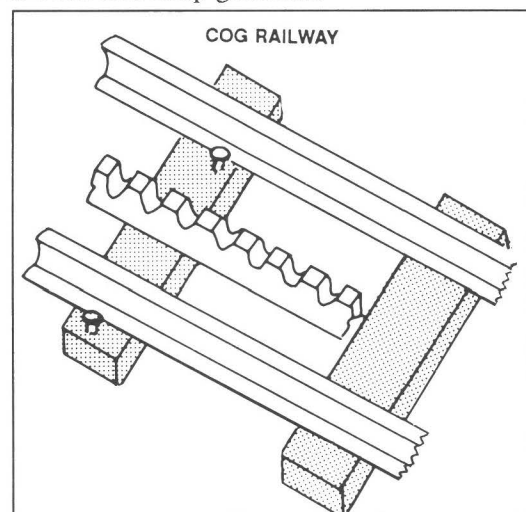

collector, current—see *current collector*.

collector road or street—see *street, collector-distributor*.

command and control system (C&C)—in rail systems, any means of adjusting and maintaining prescribed head-

ways; effecting starting and stopping, merging, and switching; and controlling other such functions. It is usually considered to include transit unit (car or train) protection, transit unit operation, and line supervision to ensure safe movement of the transit unit within the system. See also *control system, wayside*.

committee, citizen advisory—see *organizations, citizen advisory committee*.

common carrier—see *carrier, common*.

commutation ticket—in rail systems, a ticket sold at a reduced rate for a fixed or unlimited number of trips in a designated area during a specified time period.

commute—regular travel between home and a fixed location (e.g., work, school). The term is often applied only to travel in the direction of the main flow of traffic, to distinguish from reverse commute.

reverse—a commute in the direction opposite to the main flow of traffic, for example, from the central city to a suburb during the morning peak.

commuter—a person who travels regularly between home and a fixed location (e.g., work, school).

commuter bus—see *service, commuter*.

commuter rail—see *transit system, commuter rail*.

commuter rail car—see *car, commuter rail*.

commuter service—see *service, commuter*.

compensation—in labor, the entire amount of wages and fringe benefits, both current and deferred, that workers receive for their employment; see also *earnings*.

composite network—see *network, composite*.

compound catenary—see *catenary system*.

compound motor—see *motor, compound*.

compromise rail joint—see *rail joint, compromise*.

concept, marketing—see *marketing concept*.

condemnation—the process by which property is acquired for public purposes through legal proceedings under power of eminent domain.

conductor—1. In rail transit operations, the operating employee who may control the doors on rail transit vehicles, or who may have fare-collecting duties, or both. 2. In railroad operations, the operating employee in charge of the train and train crew. 3. In some bus operations, an operating employee (other than the bus driver) who collects fares and may control doors.

Congressional Budget Office—see *U.S. Government, Congressional Budget Office*.

connectivity—the ability of a public transportation network to provide service to the maximum number of origin-and-destination trip pairs through the optimal integration of routes, schedules, fare structures, information systems, and modal transfer facilities.

consist—in rail systems, the makeup or composition (number and specific identity) of individual units of a train.

consolidated metropolitan statistical area—see *area, consolidated metropolitan statistical*.

constant dollars—current dollars, that is, the value of the dollar for the year selected as a base, adjusted by using the

change in the GNP deflator index or other specified indicator between the current (base) year and the desired year. The intent of usage is to remove the distortion caused by inflation during the intervening time period. The adjusted values are termed constant measurement year dollars, for example, constant 1984 dollars.

consumer price index (CPI)—a measurement of the overall price change for a package of consumer goods purchased by a typical urban resident or worker, compiled by the Bureau of Economic Analysis of the Department of Commerce. The CPI does not measure the overall level of price change in the total economy. See also *gross national product deflator*.

contact rail—see *rail, third*.

contact shoe, overhead—see *overhead contact shoe*.

contact wire (trolley wire)—an overhead electric conductor that supplies power to streetcars, trolleybuses, and similar vehicles.

continuous brake—see *brake, continuous*.

continuous inductive train control system—see *control system, continuous train*.

continuous train control system—see *control system, continuous train*.

continuous transit system—see *transit system, continuous*.

continuous welded rail—see *rail, continuous welded*.

contract, cost-plus—see *cost-plus contract*.

contracting (contracting out)—a procedure followed by many organizations to let certain parts of the operation to private contractors, instead of having their own employees perform the work. A frequent rationale for contracting is the idea that the work can be performed more efficiently and with less expense to the main organization. See also *privatization*.

contraflow—movement in a direction opposite to the normal flow of traffic. The term usually refers to flow opposite to the heavier flow of traffic.

contraflow lane—see *lane, contraflow*.

control

deadman—see *deadman control*.

dual—see *transit system, dual-mode*; and *bus, dual-mode*.

quality—see *quality control*.

control device

grade crossing traffic—see *grade crossing traffic control device*.

traffic—see *traffic control device*.

controlled access—see *access, limited*.

controller, cam—see *cam controller*.

controls, passenger—see *passenger controls*.

control system

asynchronous network—a nonsynchronized electronic system for controlling headways. The transit unit (car or train) position is not rigidly controlled as a function of time. The longitudinal control of the transit unit is independent of line traffic when it is not in close proximity to another transit unit but usually becomes a car-following procedure when transit units are close to each other.

control system (*continued*)

augmented block guidance—an automated block control system for transit units (cars or trains) with short headways.

automatic block signal (ABS)—a system of governing train separation in which the signals are controlled by the trains themselves. The presence or absence of a train in a block is determined by a track circuit. If the circuitry fails, a restrictive signal is displayed.

automatic train—see *automatic train control system*.

block signal—a standard railroad signal system that uses a fixed signal at the entrance of a block to govern the separation of trains entering the block.

cab signal—in rail systems, a signal located in the cab, indicating a condition affecting the movement of a train and used in conjunction with interlocking signals and in conjunction with or in lieu of block signals.

car-following—a method of transit unit (car or train) longitudinal control whereby a following transit unit senses its position and velocity in relation to that of the transit unit preceding it and remains a specified distance behind it; see also *control system, asynchronous network*.

centralized traffic (CTC)—in rail systems, a traffic control system in which signals and switches are controlled from a remotely located (centralized traffic control) panel.

command and—see *command and control system*.

continuous train (continuous inductive train control)—a locomotive or self-propelled car apparatus that is constantly in contact with the track circuit and is immediately responsive to a change of conditions in the controlling section that affects train movement.

dynamic block—see *control system, moving block*.

fixed block—an automatic train control system that records the presence of a train (or a part of it) in each track section (block) and activates the signals on the line to indicate the block is occupied. In some cases, a following train is prevented from entering the block by a forced emergency stop.

manual block—a system of manually governing train movement in a block or a series of consecutive blocks by means of signals, train orders, telephone, or radio.

manual train—a system in which train movement is controlled by the operator (motorman) or engineer.

moving block (dynamic block control)—an automatic train control system that spaces trains according to their location and (sometimes) their relative velocity, stopping performance, and a prescribed factor of safety.

moving point—see *control system, moving slot*.

moving slot (point-follower control system, moving point control system)—a position control system in which the transit unit (car or train) synchronizes itself with the programmed trajectory of one of a set of moving points or slots monitored by a central computer; see also *control system, synchronous network*.

multiple-unit—a system that controls the operation of two or more rail motor cars in a train through the simultaneous control of the train by one operator.

control system (*continued*)

point-follower—see *control system, moving slot*.

quasi-synchronous network—an electronic system for controlling headways in which transit units (cars or trains) can be directed to move from one slot to another; see also *control system, synchronous network*.

synchronous network—a position control system in which the transit unit (car or train) synchronizes itself with the preprogrammed trajectory of one of a set of moving points or slots monitored by a central computer. A complete, conflict-free trajectory must be available for the assigned slot from origin to destination before the transit unit is permitted to depart. See also *control system, moving slot*.

traffic—see *control system, centralized traffic*.

wayside—a command and control system in which transit units (cars or trains) are controlled by electronic or mechanical devices along the track or other guideway.

conventional rail transport—transportation systems that consist of steel-wheeled trains running on duo-rail tracks. Trains may be self-propelled or hauled by locomotive, with diesel or electric propulsion.

convergence, point of—see *point of convergence*.

converted traffic—see *traffic, converted*.

conveyance—a means of carrying or transporting goods, people, or both.

conveyor, passenger or pedestrian—see *moving walkway*.

cordon count—in planning, a count of vehicles and people across a designated (cordon) line to determine the total flow (people and vehicles by mode and time period) into and out of the study area.

cordon line—in planning, an imaginary line circumscribing a specific geographic study area.

corner check—see *check*.

corridor—in planning, a broad geographical band that follows a general directional flow or connects major sources of trips. It may contain a number of streets and highways and transit lines and routes.

joint-use—see *joint-use corridor*.

corrugated rail—see *rail, corrugated*.

cost—the outlay or expenditure made to achieve an objective.

fixed—a cost that remains relatively constant irrespective of the level of operational activity; expenditures that do not vary with output. Examples include land, guideways, rent.

incremental (increment cost)—the net change in dollar costs that is directly attributable to a given decision or proposal when compared with some other alternative (including the existing situation or the do-nothing alternative).

marginal—the cost of producing one more unit of output.

cost (*continued*)

variable—a cost that varies in some relation to the level of output or operational activity; for example, the cost of fuel.

cost allocation—dividing costs among the various purposes or categories involved.

cost analysis, marketing—see *marketing cost analysis*.

cost-benefit analysis (CBA)—an analytical technique that compares the societal costs and benefits (measured in monetary terms) of proposed programs or policy actions. Identified losses and gains experienced by society are included, and the net benefits created by an action are calculated. Alternative actions are compared to allow selection of one or more that yield the greatest net benefits or benefit-cost ratio.

cost-effectiveness analysis (CEA)—an analytical technique used to choose the most effective method for achieving a program or policy goal. The costs of alternatives are measured by their requisite estimated monetary expenditures. Effectiveness is defined by the degree of goal attainment and may also (but not necessarily) be measured in monetary terms.

cost efficiency—a quantitative measure of efficiency or how well something contributes to the attainment of goals and objectives measured against its cost. For transportation systems, cost efficiency is usually measured as the ratio of the cost of a system to the level of service. Examples of four major unit cost measures that might be used (either separately or together) to determine cost efficiency are total operating cost per vehicle hour, total operating cost per vehicle mile, total operating cost per passenger trip, and total operating cost per passenger mile. See also *efficiency*.

costing, life cycle—see *life cycle costing*.

cost-of-living allowance—see definition of *escalator clause*.

cost-plus contract—a contract in which the purchase price is determined on the basis of actual costs plus a predetermined and mutually agreed-on fee, either a lump sum or a fixed percentage of total costs.

cost recovery ratio—the ratio of total revenues to total costs; the inverse of operating ratio. It is often used for evaluation of alternative plans.

costs—see *capital costs* and *operating costs*.

council of governments—see *organizations, council of governments*.

Council of State Governments—see *organizations, Council of State Governments*.

count—1. In transportation, a process that tallies a particular movement of people or vehicles past a given point during a stated time period. It may be a directional or a two-way value and is also known as a *traffic count*. 2. In transportation, a volume of people or vehicles.

cordon—see *cordon count*.

on-and-off—see *check*.

passenger—see *passenger count*.

passenger riding—see *check*.

count (*continued*)

traffic—see *traffic count*.

coupler—a device for connecting one rail vehicle to another. The mechanism is usually placed in a standard location at both ends of all rail cars and locomotives.

automatic—1. A coupler that operates automatically. It may also be capable of uncoupling automatically. 2. An automatic connector that joins electric or pneumatic train lines together between rail cars.

coupling

automatic—coupling achieved by very close headway control between vehicles to form trains without physical contact between the vehicles.

magnetic—coupling achieved by the use of energized electromagnets.

coverage area—see *area, coverage*.

cowcatcher—see *pilot*.

crashworthiness—the capability of a vehicle to act as a protective container and energy absorber under impact conditions.

creep—see *rail creep*.

cross elasticity—see *elasticity, cross*.

crossing

grade—a crossing or intersection of highways, railroad tracks, other guideways, or pedestrian walks, or combinations of these at the same level or grade.

highway/railroad—a place, at grade or grade separated, where highway traffic crosses railroad tracks.

railroad grade—the area where a road and a railroad cross at the same level, within which are included the railroad tracks, roadway, and roadside facilities for both road and rail traffic traversing that area.

railway—see *crossing, track*.

track (railway crossing)—an assembly of rails and frogs that allows crossing of two tracks at grade.

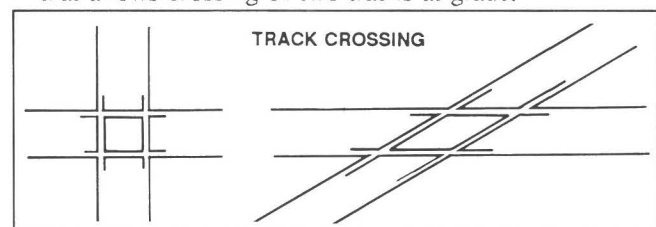

crossing control device, grade—see *grade crossing traffic control device*.

crossover—1. In rail systems, a track with two switches that connects two parallel tracks. 2. Pedestrian or vehicular links (at grade or grade separated) across a transportation facility.

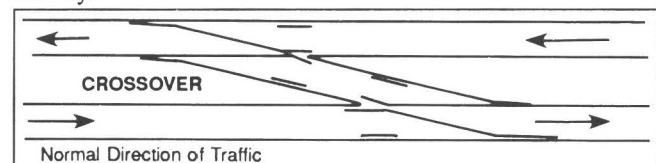

cross tie (railroad tie, tie)—the transverse member of the track structure to which the rails are fastened. Its function is

to provide proper gauge and to cushion, distribute, and transmit the stresses of traffic through the ballast to the roadbed.

crosstown service—see *service, crosstown*.

cruise speed or velocity—see *velocity, cruise*.

crush capacity or load—see *capacity, crush*.

culvert—any drainage or service structure under a roadway or guideway with a clear opening of 20 ft (6 m) or less measured along the center of the roadway or guideway.

curb-to-curb service—see *service, curb-to-curb*.

current collector—the mechanical component on an electric rail car that makes contact with the conductor that distributes the electric current; see also *overhead contact shoe, pantograph, third-rail shoe, and trolley pole*.

current dollars—see *constant dollars*.

curvature, radius of—see *radius of curvature*.

curve, demand—see *demand curve*.

cut-and-cover—a method of construction that consists of excavating the terrain from ground level, placing a structure in the excavation, and then filling over the structure.

cut line—1. In planning, an imaginary line placed at a strategic location to intercept all the links in an identified corridor. 2. In transit operations, the transverse division of a route as by a planned service change or an emergency.

cutting—see *run cutting*.

cycle speed—see *speed, overall trip*.

D

DAB—dial-a-bus; see *transportation system, dial-a-ride*.

DAR—dial-a-ride; see *transportation system, dial-a-ride*.

DBE—disadvantaged business enterprise.

DHV—design hourly volume.

DLIM—double-sided linear induction motor; see *motor, double-sided linear induction*.

DMU—diesel multiple-unit car; see *car, multiple-unit*.

DOE—Department of Energy; see *U.S. Government, Department of Energy*.

DOL—Department of Labor; see *U.S. Government, Department of Labor*.

DOT—department of transportation; see *organizations, department of transportation*; and *U.S. Government, Department of Transportation*.

DPM—downtown people mover; see *people mover, downtown*.

DSLIM—double-sided linear induction motor; see *motor, double-sided linear induction*.

dash sign—a large card placed on top of the dashboard and visible through the bus windshield, in addition to or instead of a head sign, usually denoting the type of service or destination.

data

attitudinal—see *attitudinal data*.

behavioral—see *behavioral data*.

demographic—see *demographic data*.

disaggregate—see *disaggregate data*.

data base—1. A collection of data from which information is derived and from which decisions can be made. 2. A nonredundant collection of data items processable by one or more computer applications.

days, off—see *off days*.

deadhead—1. To move a revenue vehicle in other than revenue service, for example, from one garage to another or from the end of a line to a garage. Such movement may include people using an employee pass and an occasional revenue passenger riding on an incidental basis. Also known as *deadheading*. 2. A non-fare-paying passenger, most commonly a transit system employee traveling to work using a pass.

deadheading—see *deadhead*.

deadhead or deadheading pay—see *pay, deadheading*.

deadhead time—see *time, deadhead*.

deadman control—a pedal, handle, or other form of switch, or combination thereof, that the operator must keep in a depressed or twisted position while a rail vehicle (or train) is moving. If the control is released, the power is cut off and the brakes are applied.

dead time—see *time, allowance*.

deceleration—decrease in velocity per unit time; in transit practice, often measured in feet per second squared (meters per second squared) or, in the United States, miles per hour per second.

deck—in transit systems, the floor of a rail car, bus, or boat.

dedicated funding source—a funding source that, by law, is available for use only to support a specific purpose and cannot be diverted to other uses. One example is the Highway Trust Fund.

dedicated funds—see *funds, dedicated*.

default value—a design value that is based on experience or on studied conclusions and that is used as a substitute value when an actual value is not available.

defensible space—a concept in architecture and urban design that precludes designs resulting in dark alleys, corners, or spaces where visibility and openness to other people is severely limited.

deflator, gross national product—see *gross national product deflator*.

delay time—see *time, delay*.

Delphi process (Delphi method, Delphi technique)—a method of allowing a group of individuals to deal with a complex problem as a single unit, with the goal of achieving a consensus. A typical Delphi process could involve distributing a questionnaire to participants so that they could rank problems in order of priority, summarizing the results, and providing the participants with feedback of the results, together with another questionnaire. As these steps are repeated, the distribution of individual responses narrows, and the participants move toward a consensus or to polarization.

demand—1. The quantity (of transportation) desired. 2. In an economic sense, a schedule of the quantities (of travel) consumed at various levels of price or levels of service offered (by the transportation system).

diverted—see *traffic, diverted*.

effective—the number of people or vehicles prepared to travel in a given situation, at a given price (fare or fee).

generated—see *traffic, generated*.

induced—see *traffic, induced*.

travel—see *travel demand*.

demand-actuated transportation system—see *transportation system, demand-responsive*.

demand analysis—a study of the factors that affect demand, performed by collecting data and using various analytical techniques to understand demand.

demand curve—the quantities of a given product or service that people are willing to purchase as a function of its given unit cost.

demand forecasting—see *forecasting, demand*.

demand-forecasting model—see *model, demand*.

demand jitney service—see *service, jitney*.

demand model—see *model, demand*.

aggregate—see *model, aggregate demand*.

direct—see *model, direct demand*.

disaggregate—see *model, disaggregate demand*.

demand-responsive transportation system—see *transportation system, demand-responsive*.

demographic data—statistics related to the size, density, distribution, vital statistics, social structure, and related characteristics of human populations.

Demonstration Program, Service and Methods—see *Service and Methods Demonstration Program*.

Demonstration Program, Research, Development and—see *Research, Development, and Demonstration Program*.

demotion—see *downgrading*.

density, train—see *train density*.

Department of Energy—see *U.S. Government, Department of Energy*.

Department of Health, Education, and Welfare—see *U.S. Government, Department of Health, Education, and Welfare*.

Department of Housing and Urban Development—see *U.S. Government, Department of Housing and Urban Development*.

Department of Labor—see *U.S. Government, Department of Labor*.

department of transportation—see *organizations, department of transportation*; and *U.S. Government, Department of Transportation*.

departments, U.S.—see *U.S. Government*.

dependent, transit—see *transit dependent*.

dependent variable—see *variable, dependent*.

depot—see *garage* and *terminal*.

derail—1. To run off the track. 2. A track safety device designed to guide a rail car off the rails at a selected spot to

prevent collisions or other accidents, commonly used on spurs or sidings to prevent unattended rolling cars from fouling the main line; also known as a *derailer*.

derailment—an instance of the wheels of a rail vehicle coming off the track.

describer—see *train describer*.

description, job—see *job description*.

design, preliminary—see *preliminary engineering*.

designated recipient—a public body, designated in each urban area, that must have the legal authority to receive and dispense federal funds.

design capacity—see *capacity, design*.

design hourly volume (DHV)—the amount of traffic a transportation facility is designed to carry in 1 hr.

desire line—a straight line on a map that connects the origin and destination of a trip (theoretically, the ideal or most desirable route) and may indicate by its width or density the volume of trips between that origin and destination.

destination—1. The point at which a trip terminates. 2. In planning, the zone in which a trip ends.

destination sign—a sign on a transit unit (vehicle or train) indicating the route or line number, direction, destination of the unit, or any combination thereof. Destination signs are most commonly located on the front of the transit unit but may also be located on the back, side, or both. See also *head sign*.

detail sheet—see *sheet, assignment*.

deterministic model—see *model, deterministic*.

deterministic process—a process in which all factors are known and predictable and that produces a fixed replicable output; see also *stochastic process*.

deterministic trip assignment—see *trip assignment, deterministic*.

detour—a temporary change in a portion of a transit route or highway; see also *reroute*.

development, joint or joint-use—see *joint development*.

Development and Demonstration Program, Research—see *Research, Development, and Demonstration Program*.

Development Program, Transit—see *Transit Development Program*.

deviation, point-to-point—see *point-to-point deviation*.

device

grade crossing traffic control—see *grade crossing traffic control device*.

signal-actuating—see *pedestrian signal-actuating device* and *vehicle signal-actuating device*.

traffic control—see *traffic control device*.

dial-a-bus or dial-a-ride—see *transportation system, dial-a-ride*.

diamond lane—see *lane, diamond*.

diesel-electric locomotive—see *locomotive, diesel-electric*.

diesel-hydraulic locomotive—see *locomotive, diesel-hydraulic*.

diesel multiple-unit car—see *car, multiple-unit*.

diesel rail car—see *car, rail diesel*.

differential, shift—see *shift differential*.

differential fare—see *fare, differential*.

differential technique, semantic—see *semantic differential technique*.

direct current motor—see *motor, direct current*.

direct demand model—see *model, direct demand*.

directional route miles—see *route miles*.

directional split—the proportional distribution between opposite flows of traffic on two-way facilities.

directness, coefficient of—see *coefficient of directness*.

disability, public transportation—see definition of *handicapped*.

disadvantaged, transportation—see *transportation disadvantaged*.

disadvantaged business enterprise (DBE)—a business owned and controlled by one or more socially and economically disadvantaged individuals, including Black Americans, Hispanic Americans, Native Americans, Asian-Pacific Americans, or Asian-Indian Americans, and any other minorities or individuals found to be disadvantaged by the Small Business Administration under Section 8(a) of the Small Business Act; see also *minority business enterprise* and *women's business enterprise*.

disaggregate data—information on the individual as opposed to averages or similar descriptors of a group of individuals.

disaggregate demand model—see *model, disaggregate demand*.

disc brake—see *brake, disc*.

discharge—1. In labor, the dismissal of a worker from employment. Discharge usually occurs as a result of unsatisfactory performance, for example, insubordination, absenteeism, accidents, or inefficiency. 2. In transit operations, to let passengers exit the vehicle.

discount rate—in cost-benefit analysis, an interest rate used to reduce the value of benefits or costs accruing in future years back to their current worth (net present value). If the discount rate is 4 percent, \$1.04 a year from now is of equal value to \$1.00 today.

discretionary funds—see *funds, discretionary*.

disincentive—something that discourages people from acting in a certain way. For example, high parking fees or tolls are disincentives to automobile use.

dismissal allowance or pay—see *pay, severance*.

dispatcher—1. In bus operations, the individual who assigns buses to runs, makes up work assignments to fill runs, directs the operators at the start of their assignments, and in some cases, maintains a constant awareness of status of the operation, via radio, telephone, or other means. 2. In rail operations, an operating person within a control center whose function it is to dispatch transit units (cars or trains), monitor their operation, and intervene in the event of disruption of schedule or when any change in service or routing is required. 3. In demand-responsive transportation, the person who assigns the vehicles to customers and notifies

the appropriate drivers and who may schedule and route vehicles and monitor their operation.

dispatching—1. In rail operations, the process of starting a transit unit (car or train) into service from a terminal, yard, or transfer track. 2. In demand-responsive transportation systems, the process of relaying service instructions to drivers. The procedure may include vehicle scheduling, routing, and monitoring, and it can be manual or partly or fully automated. 3. The relaying of service instructions to vehicle drivers or operators.

dispatch point—1. The location at which operating employees receive their assignments. 2. The location at which trips are started or restarted.

distance

linked trip—see *trip distance, linked*.

total travel—see *trip distance, linked*.

distribution

flow—see *trip assignment*.

Fratat—see *model, Fratat*.

trip—see *trip distribution*.

trip length frequency—see *trip length frequency distribution*.

distributor street—see *street, collector-distributor*.

district—in planning, a grouping of contiguous zones.

central business—see *central business district*.

enumeration—see *census enumeration district*.

outlying business district—see *outlying business district*.

transit—see *transit district*.

divergence, point of—see *point of divergence*.

diversion trip assignment—see *trip assignment, diversion*.

diverted demand or traffic—see *traffic, diverted*.

division—1. In transit systems, a term sometimes applied to a bus garage or rail barn and maintenance or servicing facility. 2. A segment of a rail or bus operation, either intracity or intercity, geographical in nature, with its own hierarchy of management and, usually, assigned personnel. 3. In bus operations, a group of routes that operates out of a common storage depot. 4. The portion of the railroad assigned to the supervision of the manager or superintendent, usually consisting of barn or carhouse, yards, stations, and sidings.

division of work—see *work sharing*.

dock—see *bus bay*.

dollars, constant or current—see *constant dollars*.

domain, eminent—see *eminent domain*.

do-nothing alternative—see *no-action alternative*.

door-to-door service—see *service, door-to-door*.

double—see *extra section*.

double-deck car—see *car, double-deck*.

double-decker bus—see *bus, double-decker*.

double-ended car—see *car, bidirectional*.

double-ended transit unit (bidirectional transit unit)—a rail car or train with an operating cab at each end.

double-sided linear induction motor—see *motor, double-sided linear induction*.

double-track main line—see *line, double-track main*.

downgrading (demotion)—reassignment of an employee to a task or job that requires lower skills and usually has a lower rate of pay.

downtime—1. A brief period during which workers are unable to perform their tasks, while they wait for vehicle replacement, repair, parts or supplies, etc. 2. A payment made to employees for such lost time. 3. A period during which a vehicle is inoperative because of repairs or maintenance.

downtown people mover—see *people mover, downtown*.

driver mark-up—see *sheet, assignment*.

drivers, booked—see *booked drivers*.

driving wheels—wheels that are powered by a motor or engine and that provide the tractive effort, through contact with the running surface, that propels the vehicle.

dual control or mode—see *transit system, dual-mode*; and *bus, dual-mode*.

dual-control or dual-mode bus—see *bus, dual-mode*.

dual-mode transit system—see *transit system, dual-mode*.

dual-mode vehicle—see *vehicle, dual-mode*.

dual-powered bus—see *bus, dual-mode*.

dual-powered locomotive—see *locomotive, dual-powered*.

dual-powered turboelectric car—see *car, dual-powered turboelectric*.

dual-power propulsion system—see *propulsion system, dual-power*.

duckout—see *bus bay*.

duty—see *shift*.

dwelling unit—a room or group of rooms, occupied or intended for occupancy as separate living quarters, by a family or other group of people living together or by a person living alone.

dwelling unit survey—see *survey, home interview*.

dwelt time—see *time, dwell*.

dynamic block control system—see *control system, moving block*.

dynamic brake—see *brake, dynamic*.

dynamic routing—in demand-responsive transportation systems, the process of constantly modifying vehicle routes to accommodate service requests received after the vehicle began operations, as distinguished from predetermined routes assigned to a vehicle.

E

E&H—elderly and handicapped.

EA—environmental assessment.

ECE—external combustion engine; see *engine, external combustion*.

ED—enumeration district; see *census enumeration district*.

EIS—environmental impact statement.

EMU—electric multiple-unit car; see *car, multiple-unit*.

EPA—Environmental Protection Agency; see *U.S. Government, Environmental Protection Agency*.

earnings—in general, the remuneration (pay) of a worker or group of workers for services performed during a specific period of time; see also *compensation*.

average—the arithmetic mean of the total earnings of a group of workers.

gross—a worker's total earnings, including overtime and spread premiums, shift differentials, production bonuses, cost-of-living allowances, instruction allowances, commission, and so on, before taxes and deductions.

straight time—a worker's earnings, excluding overtime payments, shift differential, and other extra monetary payments.

easement—a right acquired by one party to use or control property belonging to another party for a designated purpose, such as public utilities, streets or highways, transit lines.

effect, halo—see *halo effect*.

effective demand—see *demand, effective*.

effectiveness—1. In transportation, the correspondence of provided service to intended output or objectives, particularly the character and location of service; in other words, producing the intended result (doing the right things). 2. In transit, the degree to which the desired level of service is being provided to meet stated goals and objectives; for example, the percentage of a given service area that is within the desired $\frac{1}{4}$ mi (0.4 km) of a transit stop.

measure of—see *performance indicator*.

effective operating speed—see *speed, overall trip*.

effective velocity—see *velocity, effective*.

efficiency—the ratio of output (e.g., level of service provided) to input (e.g. cost or resource usage), that is, providing the desired result with a minimum of effort, expense, waste, and so on (doing things right).

effort, tractive—see *tractive effort*.

egress time—see *time, egress*.

elasticity

cross—a measure of the change in demand of one good or service (e.g., ridership on transit) with a change in price of another (e.g., price of gasoline).

fare—a measure of the change (increase or decrease) in ridership with a change in fare.

income—a measure of the change in demand of a good or service (e.g., ridership on transit) with a change in one's income.

price—a measure of the change in demand of a good or service (e.g., ridership on transit) with a change in price of the good or service (e.g., fares).

elderly and handicapped (E&H)—people who may have special needs for services such as transportation. Transportation especially provided for their benefit is called *elderly and handicapped (E&H) transportation*. Transit operations may include discounted fares (*E&H fares*) for their benefit. The minimum age for elderly people varies by the program (e.g., 55+, 60+, 65+). See also *handicapped*.

electrically locked switch—see *switch, electrically locked*.

electric brake—see *brake, dynamic*.

electric bus—see *bus, electric*.

electric incline railway (incline)—a railway in which vehicles are carried or conveyed by an electric hoist along inclined tracks. The hoist carries a single car, with or without counterweights, or two cars in balance. The system is used to overcome steep gradients. See also *funicular railway*.

electric locomotive—see *locomotive, electric*.

electric motor—see *motor*.

electric multiple-unit car—see *car, multiple-unit*.

electric rail car—see *car, electric rail*; and *car, rectifier electric motor*.

Electric Railway Presidents' Conference Committee—see *organizations, Presidents' Conference Committee*.

electric train line circuit—a continuous electric circuit between all units of the train. The circuit is provided with control stations to permit the control of traction motors and other equipment from any operator's cab on the train (or, in special cases, from one cab only).

electric trolleybus—see *trolleybus*.

electrification (railway electrification)—in rail systems, a term used to describe the installation of overhead wire or third-rail power distribution facilities to enable operation of electrically powered transit vehicles.

electrified track—see *track, electrified*.

electrodynamic brake—see *brake, dynamic*.

electromagnetic brake—see *brake, track*.

electropneumatic brake—see *brake, electropneumatic*.

element

annual—see *annual element*.

long-range—see *long-range element*.

transportation systems management—see *transportation systems management element*.

elephant train—see *train, elephant*.

elevated, the—see *transit system, rail rapid*.

elevated guideway—see *guideway, elevated*.

elevated-on-fill guideway—see *guideway, elevated-on-fill*.

emergency application or braking—see *braking, emergency*.

emergency transfer—see *transfer, emergency*.

eminent domain—the power to take private property for public use without the owner's consent, on payment of just compensation; see also *condemnation*.

employee, part-time—see *part-time employee*.

employees, operating—see *operating employees*.

end

head—see *head end*.

trip—see *trip end*.

energy, kinetic—see *kinetic energy*.

engine—1. A mechanism for converting energy (heat or other) into mechanical work. In modern transportation, the engine's source of energy is usually liquid or gaseous fuel. See also *motor*. 2. In common usage, the term is widely used for devices that produce motion. 3. A locomotive.

external combustion (ECE)—an engine in which fuel combustion takes place outside the cylinder, turbine, or the like and in which energy is turned into mechanical force; for example, a steam engine.

gas turbine—an internal combustion engine in which the hot compressed gases of combustion drive a turbine.

internal combustion (ICE)—an engine in which the power is developed through the expansive force of fuel that is fired or discharged within a closed chamber or cylinder.

radio-controlled (slave unit)—in passenger trains, an unmanned propulsive unit within a train that is separated by rail cars from the lead unit but controlled from it by radio signals.

steam—an engine driven or worked by steam; specifically, a reciprocating engine that has a piston driven by steam in a closed cylinder.

turbine—a rotary engine actuated by the reaction or impulse or both of a current of fluid or gas subjected to pressure. A turbine is usually made with a series of curved vanes on a central rotating spindle.

engineering

preliminary—see *preliminary engineering*.

value—see *value engineering*.

enterprise

disadvantaged business—see *disadvantaged business enterprise*.

minority business—see *minority business enterprise*.

women's business—see *women's business enterprise*.

enumeration district, census—see *census enumeration district*.

environment—the physical conditions that exist within a given area that will be affected by a proposed project, including land, air, water, minerals, flora, fauna, ambient noise, and objects of historic or aesthetic significance.

environmental assessment (EA)—an environmental study used under the National Environmental Policy Act of 1969 to determine whether an environmental impact statement is required.

environmental impact statement (EIS, I02 statement)—a comprehensive study of likely environmental impacts that will result from major federally assisted projects. An EIS is required by the National Environmental Policy Act of 1969.

Environmental Protection Agency—see *U.S. Government, Environmental Protection Agency*.

equity—in transportation, a normative measure of fairness among transportation users.

equivalence, passenger car—see *passenger car equivalence*.

escalator clause—a provision in a contract that stipulates that wages or prices are to be automatically increased or decreased at specific times according to a schedule that is usually related to changes in the cost of living (*cost-of-living allowance, COLA*) as measured by a designated index or other standard (e.g., the consumer price index). The provision may also apply to any tie between employee benefits and the cost of living, as in a pension plan.

estimate, standard error of—see *standard error of estimate*.

evaluation, impact—see *impact analysis*.

evening shift—see *shift, evening*.

exact fare—see *fare, exact*.

excess time—see *time, excess*.

exclusion, categorical—see *categorical exclusion*.

exclusive bus lane—see *lane, exclusive transit*.

exclusive carpool lane—see *lane, exclusive carpool*.

exclusive ride taxi—see *service, taxicab*.

exclusive right-of-way—see *right-of-way, exclusive*.

exclusive transit facilities—transportation system infrastructure elements that are set aside for the use of transit vehicles only. Examples include some freeway ramps, bus lanes, off-street bus loading or unloading areas, and separated and fully controlled rights-of-way.

exclusive transit lane—see *lane, exclusive transit*.

exclusive transit right-of-way—see *right-of-way, exclusive transit*.

expansion factor—a statistical value used to adjust a sample to represent an entire population, area, or universe.

express bus—see *service, express bus*.

express service—see *service, express*.

expressway—a divided arterial highway for through traffic. An expressway has full or partial control of access and generally has grade separations at major intersections.

extension, point of—see *point of extension*.

external combustion engine—see *engine, external combustion*.

external-external trip—see *trip, external-external*.

external-internal trip—see *trip, external-internal*.

extra board (*spare board*)—1. A roster of open (extra) runs and assignments. 2. A pool of employees available to cover unfilled runs or extra work.

extra or extra operator—see *operator, extra board*.

extra run—see *run, open*.

extra section (*double*)—a second bus added to accompany a regularly scheduled bus, used to handle passenger overloads.

extra work—see definition of *operator, extra board*.

F

FARE—Financial Accounting Reporting Elements.

FCC—Federal Communications Commission; see *U.S. Government, Federal Communications Commission*.

FHWA—Federal Highway Administration; see *U.S. Government, Federal Highway Administration*.

FONSI—finding of no significant impact.

FRA—Federal Railroad Administration; see *U.S. Government, Federal Railroad Administration*.

facilities

accessible transportation—see *accessible transportation facilities*.

exclusive transit—see *exclusive transit facilities*.

facility

intermodal transfer—see *transit center*.

parking—see *parking facility*.

factor

expansion—see *expansion factor*.

F or friction—see *friction factor*.

growth—see *growth factor*.

K—see *K factor*.

load—see *load factor*.

peak-hour—see *peak-hour factor*.

travel time—see *travel time factor*.

factor analysis—an analytical technique for identifying the major interrelationships between variables, frequently used in transportation demand analysis.

fail-safe—incorporating a feature that ensures that malfunctions that affect safety will cause the system to revert to a state that is safe.

fare—1. The required payment for a ride on a public transportation vehicle. It may be paid by any acceptable means, for example, cash, token, ticket, transfer, farecard, voucher, or pass or user fee. 2. A passenger who pays a fare.

adult cash—basic full fare paid by one person for one ride, excluding transfer and zone charges.

average—the arithmetic average of all fares paid by all revenue passengers, including those who received special or reduced fares. It is usually derived by or generally equivalent to dividing total fare revenue by total origin-to-destination trips, although in many cases it is based on unlinked trips.

base (*basic fare, regular fare*)—the price (with no discounts) charged to an adult for regular local service or, for systems with zone pricing, a one-zone fare with no discounts, that is, what it costs an adult paying a single cash fare to take a one-zone ride.

differential—1. A method of travel pricing that varies fares according to the time of day, direction, distance, or other characteristic of the ride or pertinent circumstances. 2. An additional charge for a trip, based on the time of

fare (*continued*)

day, direction, distance, or other special characteristic of the ride.

E&H—see definition of *elderly and handicapped*.

exact—a transit operations policy that precludes the making of change for passengers. A passenger must therefore have the correct change for the fare or else overpay it.

flat—a method of travel pricing that uses a single fare for the entire service area regardless of the trip's distance, time of day, area of travel, or other characteristics.

graduated—a fare that is proportional to the distance traveled (also known as *mileage fare*) or to the length of time that a passenger may ride on a service.

mileage—see *fare, graduated*.

off-peak or peak—see *fare, time-of-day*.

reduced—a special fare for children, students, senior citizens, or others that is less than the regular fare.

regular—see *fare, base*.

time-of-day—a fare that varies by time of day. It is usually higher during peak travel periods (*peak fare*) and lower during nonpeak travel periods (*off-peak fare*).

zone (zoned fare)—a method of transit pricing that is based on the geographical partitioning of the service area. The price is determined by the location and number of zones traversed. Zone fares are frequently used as a method of charging graduated or distance-based fares but may also be used to provide for differential fares for certain markets.

farebox—a device that accepts coins, bills, tickets, tokens, or other fare media given by passengers as payment for rides.

registering (register)—a farebox that also receives and records fare information.

farebox recovery ratio—see *fare recovery ratio*.

farebox revenue—see *revenue, farebox*.

farecard—see *magnetic farecard*.

farecard reader—a device that determines the value stored in a farecard when the farecard is inserted. A farecard reader may also be used for appropriately altering the value stored in a farecard. The device is usually used with a passenger turnstile or gate.

fare collection system—the procedures and devices used to collect fares and to accumulate and account for fares paid.

automatic (AFC)—the controls and equipment that automatically admit passengers on insertion of the correct fare in an acceptable form, which may be coins, tokens, tickets, or farecards (stored value farecards must be inserted again on exit, at which point an additional fare may be required). The system may include special equipment for transporting and counting revenues.

self-service, barrier-free (barrier-free fare collection system, honor system)—a fare collection system that has no paid areas or fare-registering turnstiles. This system requires that the passenger be able to display proof of payment (e.g., validated ticket, prepaid pass, valid transfer) while on board the transit vehicle. Compliance is

fare collection system (*continued*)

monitored through random checking by designated transit employees.

fare elasticity—see *elasticity, fare*.

faregate—see *fare-registering turnstile*.

fare recovery ratio (farebox recovery ratio)—the ratio of fare revenue to operating expenses; see also *operating ratio*.

fare-registering turnstile (faregate)—a turnstile that unlocks to allow a passenger to enter the paid area after a pass or farecard or the correct amount of money or tokens is inserted in it. It records the fares paid.

fare structure—the system set up to determine how much is to be paid by various categories of passengers using the system in any given circumstance.

far-side stop—see *stop, far-side*.

feasibility study—a study to determine the suitability of a proposed action, such as establishment of transit service in a given area.

federal agencies—see *U.S. Government*.

Federal Communications Commission—see *U.S. Government, Federal Communications Commission*.

Federal Domestic Assistance, Catalog of—see *Catalog of Federal Domestic Assistance*.

Federal Highway Administration—see *U.S. Government, Federal Highway Administration*.

Federal Railroad Administration—see *U.S. Government, Federal Railroad Administration*.

Federal Register—the official public notice of government actions. It publishes all current Presidential proclamations and Executive Orders, as well as federal agency regulations that have general applicability and legal effect. It is published five times a week.

Federal Regulations, Code of—see *Code of Federal Regulations*.

feedback—the return to the input of a part of the output of a process to obtain or approach a final answer.

feeder service—see *service, feeder*.

ferryboat—a vessel that carries passengers, vehicles, or both over a body of water, usually for short distances and with frequent, regular service. A ferryboat is generally a conventional shallow-draft boat, but hydrofoils, catamarans, and hovercraft are also used. Often such vessels are double-ended with a pilot house at each end for control purposes so that the vessel need not be turned around for the next trip.

few-to-few service—see *service, few-to-few*.

few-to-many service—see *service, few-to-many*.

F factor—see *friction factor*.

Financial Accounting and Reporting Elements (FARE, Uniform Financial Accounting and Reporting Elements)—a uniform financial and operating data reporting system developed by the federal government for the mass transit industry.

finding of no significant impact (FONSI)—a document that describes the reasons that a project will not have a significant effect on the environment and therefore does not require the preparation of an environmental impact statement under the National Environmental Policy Act of 1969.

first-track miles or kilometers—see *right-of-way miles*.

fixed block control system—see *control system, fixed block*.

fixed cost—see *cost, fixed*.

fixed guideway transit system—see *transit system, fixed guideway*.

fixed route—see *transportation system, fixed route*.

fixed shift—see *shift, fixed*.

fixed signal—see *signal, fixed*.

flag drop charge—the charge for an initial distance (usually specified by regulation) for taxi service. It is actually the minimum fare.

flag stop service—see *service, flag stop*.

flange, wheel—see *wheel flange*.

flasher—in rail systems, the flashing light at railroad grade crossings that warns motorists, bicyclists, and pedestrians of approaching trains.

flat fare—see *fare, flat*.

flat spot—loss of roundness of the tread of a railroad wheel, caused by wheel sliding.

flat wheel—a rail car wheel that has a flat spot on the tread.

fleet (rolling stock)—the vehicles in a transit system. Usually, “fleet” refers to highway vehicles and “rolling stock” to rail vehicles.

base-period—see *base-period fleet*.

fleet capacity—see *capacity, fleet*.

flexible work hours or flextime—see *work hours, flexible*.

flow, passenger—see *passenger flow*.

flow distribution—see *trip assignment*.

flow map (traffic volume flow map)—a map showing the actual transportation system, on which the width of the band depicting a route is in direct proportion to the volume of vehicles or passengers using the route.

flow rate (rate of flow)—in transportation, the number of units (passengers or vehicles) passing a point on a transportation facility during some period of time, usually counted or recomputed in units per hour. For example, if 8 buses pass a point in the first half hour and 15 in the second, the volume for the hour is 23. However, the flow rate for the first half hour is 16 buses/hr, and for the second half hour the flow rate is 30 buses/hr. See also *volume*.

force, tractive—see *tractive effort*.

forecasting—in planning, the process of determining the future conditions, magnitudes, and patterns within the urban area, such as future population, demographic characteristics, travel demand.

demand—in transportation planning, a technique for estimating the number of potential users of a system and their desired travel times and routes.

forecast year—in planning, the terminal year for a projection. Usually designates the year in the future for which the improvements embraced in the (transportation) plan are to be designed.

foreign carrier—see *carrier, foreign*.

formula funds—see *funds, formula*.

four-stage model—see *urban transportation modeling system*.

four-step planning process—see *urban transportation modeling system*.

fourth rail—see *rail, fourth*.

franchise—in transportation, the privilege or right granted a person, group, or organization by a government authority to provide general or specific transportation services, usually applicable to a geographically specified area.

Fratat model—see *model, Fratar*.

free area—see *area, free*.

free transfer—see *transfer, free*.

freeway—a divided highway for through traffic that has full access control and grade separations at all intersections. In some countries, it is also known as a *motorway*.

metered—a freeway to which access is controlled by entrance ramp signals that use fixed-time signal settings or is regulated by a computerized surveillance system. This procedure is used to prevent freeway congestion. See also *bus priority system, metered freeway*.

freewheeling (coasting)—of a vehicle, running without influence of either the propulsion or braking systems, that is, with tractive and braking forces at zero.

frequency, service—see *service frequency*.

frequency coefficient, riding—see *riding frequency coefficient*.

frequency distribution, trip length—see *trip length frequency distribution*.

friction brake—see *brake, friction*.

friction factor (F factor)—in a gravity model, the empirically determined value that expresses the effect of spatial separation between zones on trip interchanges.

fringe, urban—see *urban fringe*.

fringe area—see *area, fringe*.

fringe benefit—an employment-related entitlement provided in addition to a worker’s wages or salary that is paid for in part or wholly by the employer. Examples include paid leaves (vacations, holidays, sick leaves, etc.), pensions, social security, and health and life insurance plans.

fringe parking—see *parking, fringe*.

frog—a track component used at the intersection of two running rails to provide support and guidance for the wheels. It allows wheels on each rail to cross the other rail.

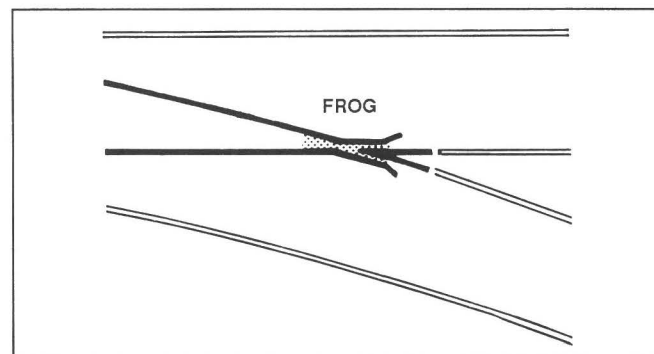

frontage road—see *road, frontage*.

fuel—in the conventional sense, a material or combination of materials that, when burned with air, produces heat and, often, explosive or mechanical energy.

alternative—a liquid or gaseous nonpetroleum fuel. The term usually refers to alcohol fuels, mineral fuels, natural gas, and hydrogen.

synthetic (synfuel)—usually refers to liquid or gaseous fuels derived from mineral feedstocks, such as coal, oil shale, and tar sands, instead of crude petroleum.

full accessibility—see *accessibility, handicapped*.

full crew law—a law or regulation that requires a minimum number of workers to be present on particular job assignments.

full service braking—see *braking, maximum service*.

Fund, Highway Trust—see *Highway Trust Fund*.

funding source, dedicated—see *dedicated funding source*.

funds

dedicated—funds collected and allocated for a specific program or purpose.

discretionary—1. Any funds whose distribution is not automatic. Decisions on the distribution of discretionary funds are usually made by an agency or person on the basis of that agency's or person's choice or judgment and in accordance with criteria set out in laws or regulations. 2. Funds granted at the discretion of the funding agency in the amount it desires.

formula—funds distributed or apportioned to qualifying recipients on the basis of formulas described in law or regulations, for example, funds in the Section 18 program for Small Urban and Rural Transit Assistance.

funicular railway—a passenger transportation mode consisting of a pair of rail vehicles (or short trains) permanently attached to two ends of the same cable, counterbalancing each other. It may have a single track with a turnout or a double track. This system is used to overcome steep gradients. See also *electric incline railway*.

furniture, street—see *street furniture*.



GNP deflator—gross national product deflator.

GRT—group rapid transit; see *transit system, group rapid*.

gallery car—see *car, gallery*.

garage—in bus systems, the location in which buses are stored and serviced and where operators report for work and receive supplies and assignments. It is also sometimes known as a *depot* or *barn*.

gas turbine engine—see *engine, gas turbine*.

gas turbine locomotive—see *locomotive, gas turbine*.

gate, bus—see *bus gate*.

gates, pantograph—see *pantograph gates*.

gather service—see *service, many-to-one*.

gauge

broad (wide gauge)—a rail track gauge that is more than 4 ft 8.5 in (1.435 m) wide. The distinction is often made that wide gauge is slightly greater but broad gauge is substantially greater than 4 ft 8.5 in.

narrow—a rail track gauge that is less than 4 ft 8.5 in (1.435 m) wide.

standard—a rail track gauge that is 4 ft 8.5 in (1.435 m) wide.

track—the distance between the inside faces of the two rails of a track measured $\frac{5}{8}$ inch (1.59 cm) below the top of the rails and perpendicular to the gauge line.

wide—see *gauge, broad*.

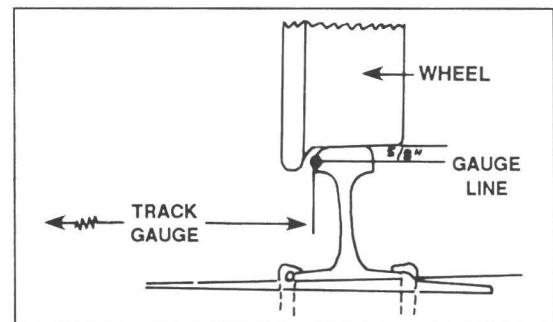

gauge line—a line $\frac{5}{8}$ in. (1.59 cm) below the top of the centerline of the head of the running rail along the side that is nearer the center of the track.

gear, running—see *running gear*.

general share model—see *model, general share*.

generated demand or traffic—see *traffic, generated*.

generation, trip—see *trip generation*.

generator—in mechanics, a rotating electrical machine that changes mechanical energy into electrical energy.

trip—see *trip generator*.

goals—1. In policy-making and planning, broad statements of directions in which planning or action is aimed; general value statements representing an ideal end that the community wishes to attain. 2. In transit operations, the general philosophy and desires of the transit organization that are theoretically attainable and provide guidance for future development; see also *objective*.

government, U.S.—see *U.S. Government*.

governments, council of—see *organizations, council of governments*.

governor—1. A device that holds the speed of an engine approximately constant regardless of the load. 2. A device that keeps an engine from exceeding a predetermined speed.

grade—rise in elevation within a specified distance. As an example, a 1-percent grade is a 1 ft (m) rise in elevation in 100 ft (m) of distance (measured horizontally).

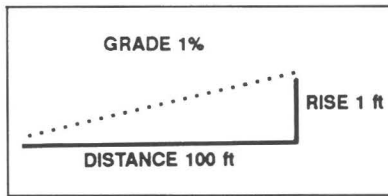

grade crossing—see *crossing, grade*.

grade crossing protection signal—see *signal, grade crossing protection*.

grade crossing traffic control device—any form of protective or warning device installed at a railroad or transit guideway grade crossing for the protection of highway or street traffic.

grade separation—a vertical separation of intersecting facilities (road, rail, etc.) by the provision of crossing structures.

graduated fare—see *fare, graduated*.

grants, block—see *block grants*.

graveyard shift—see *shift, night*.

gravity model—see *model, gravity*.

grid network—see *network, grid*.

gripman—operator of a cable car.

gross earnings—see *earnings, gross*.

gross national product deflator (GNP deflator)—an index of the level of overall price changes in the economy (gross national product). It is assembled by the U.S. Department of Commerce and provides a measure of inflation for comparison with price or cost changes of individual products or sectors of the economy. See also *consumer price index*.

ground access—see *access, ground*.

ground effect machine—see *vehicle, air cushion*.

group, low mobility—see *transportation disadvantaged*.

group rapid transit—see *transit system, group rapid*.

group riders—see *riders, group*.

growth factor—a value used to adjust existing data to produce an estimate for some future year.

growth model—see *model, regional growth*.

guarantee, pay—see *pay guarantee*.

guaranteed annual wage plan—a plan whereby employees who meet certain qualifications are assured wage income or employment for a full year or the greater part of a year.

guarantee time—see *time, guarantee*.

guardrail—1. In rail construction, a rail or other device that is laid parallel to the running rails of a track to prevent derailment or to hold the wheels in alignment and prevent their flanges from striking the points of turnouts, crossing frogs, or the points of switches. 2. In highway construction, traffic barriers used to prevent errant vehicles from leaving their designated areas and striking fixed objects or entering hazardous areas.

guide, run—see *paddle board*.

guideway—in transit systems, a track or other riding surface (including supporting structure) that supports and physically guides transit vehicles specially designed to travel exclusively on it.

elevated—a grade-separated guideway on a structure that provides overhead clearance for vehicles that operate on the prevailing surface of the terrain; see also *aerial structure*.

elevated-on-fill—a grade-separated guideway above the prevailing surface of the terrain that is supported by an embankment instead of by a structure.

open cut—a guideway below the prevailing surface of the terrain in a trenchlike excavation (cut).

H

HEW—Department of Health, Education and Welfare; see *U.S. Government, Department of Health, Education, and Welfare*.

HOV—high-occupancy vehicle; see *vehicle, high-occupancy*.

HOV lane—high-occupancy-vehicle lane; see *lane, high-occupancy-vehicle*.

HRIS—Highway Research Information Service.

HSGT—high-speed ground transportation; see *transportation system, high-speed ground*.

HUD—Department of Housing and Urban Development; see *U.S. Government, Department of Housing and Urban Development*.

habit coefficient, riding—see *riding frequency coefficient*.

hail—a hand or voice signal (or both) used to request a cruising vehicle to stop and accept passengers.

halo effect—the tendency to assign a favorable or unfavorable feature of an object to other characteristics of the same or associated objects.

handicapped—people who have physical or mental impairments that substantially limit one or more major life activities. In the context of transportation, the term usually refers to people for whom the use of conventional transit facilities would be impossible or would create a hardship. These people are also known as *transportation handicapped* or as people who have a *public transportation disability*.

ambulatory—handicapped people who are able to move around without assistance. In the context of transportation, the term usually refers to people who, although handicapped, are able to use regular transportation services without assistance or special equipment such as wheelchair lifts.

handicapped (*continued*)

nonambulatory—handicapped people who are unable to move about without assistance, for example, those confined to a wheelchair.

handicapped accessibility—see *accessibility, handicapped*.

head end—the beginning or forward portion of any train.

head sign—a sign indicating the destination of the transit unit (vehicle or train), usually located above the windshield.

headway—the time interval between the passing of the front ends of successive transit units (vehicles or trains) moving along the same lane or track (or other guideway) in the same direction, usually expressed in minutes; see also *service frequency*.

base—the scheduled headway between transit unit (vehicle or train) trips during an off-peak (usually midday) period.

policy—1. Headway prescribed by reasons other than matching capacity to demand. 2. The maximum permissible headway as established by the transit agency or (often) the policy board, usually for off-peak, low-demand periods.

headway management—a technique for managing the operation of transit units (vehicles or trains) that focuses on maintaining a certain spacing between units on the same line, instead of on adhering to a timetable. For example, if units become bunched, corrective measures might include delaying the units at the rear of the bunch to provide regular headways and hence load distribution, even at the expense of reducing timetable adherence.

headway sheet—see *sheet, headway*.

heater, switch—see *switch heater*.

heavy rail—see *transit system, rail rapid*.

high-occupancy vehicle—see *vehicle, high-occupancy*.

high-occupancy-vehicle lane—see *lane, high-occupancy-vehicle*.

high platform—see *platform, high*.

high rail—see *rail, high*.

high-speed ground transportation—see *transportation system, high-speed ground*.

high voltage—see *voltage, high*.

highway

arterial—a general term denoting a major highway used primarily by through traffic, usually on a continuous route.

belt (beltway)—an arterial highway for carrying traffic around an urban area or portion thereof.

radial—an arterial highway that leads to or from an urban center in a radial manner.

highway, street, or road—1. General terms denoting a public way for purposes of vehicular travel, including the entire area within the right-of-way. The recommended usages are as follows: in urban areas, highway or street; in rural areas, street or road. 2. Street, in common general usage, refers to the vehicular travel way, as distinguished from the sidewalk (the pedestrian travel way).

Highway Research Information Service (HRIS)—a computer-based information storage and retrieval system developed by the Transportation Research Board with financial support from the state highway and transportation departments and the Federal Highway Administration. It consists of summaries of research projects in progress and abstracts of published works.

highway/RR crossing—see *crossing, highway/railroad*.

highway system, automated—see *automated highway system*.

Highway Trust Fund—the federal account established by law to hold receipts collected by the government and earmarked for highway programs and a portion of the federal mass transit program. It is supported by the federal gasoline tax and other user taxes.

hold time—see *time, allowance*.

home-based trip—see *trip, home-based*.

home interview survey—see *survey, home interview*.

honor system—see *fare collection system, self-service, barrier-free*.

horsepower—a measure of power approximately equivalent to 746 watts or to 550 foot-pounds of work in 1 second.

hot, running—see *running hot*.

hour(s), rush—see *peak*.

hours, work—see *work hours*.

hub miles (hub kilometers)—actual logged miles (kilometers) of vehicle operation, usually read from a hubometer or odometer.

hunting, truck—see *truck hunting*.



ICC—Interstate Commerce Commission; see *U.S. Government, Interstate Commerce Commission*.

ICE—internal combustion engine; see *engine, internal combustion*.

IPG—Intermodal Planning Group; see *U.S. Government, Intermodal Planning Group*.

ITA—International Taxicab Association; see *organizations, International Taxicab Association*.

ITE—Institute of Transportation Engineers; see *organizations, Institute of Transportation Engineers*.

ignitron electric car—see *car, rectifier electric motor*.

impact, finding of no significant—see *finding of no significant impact*.

impact analysis (impact evaluation)—in transportation planning, that part of the process in which there is an evaluation of the effects of an existing or proposed transportation project on social, economic, and environmental factors or variables, for example, on air pollution, energy consumption, accidents, socioeconomic effects.

impact statement—see *environmental impact statement*.

impedance—1. In transportation generally, any condition that restricts or discourages travel, or a measure of that condition. 2. In transportation modeling, any such condition explicitly accounted for within the model. Time and costs are the factors usually considered, but others may also be examined.

impedance matrix—in planning, an array of zone-to-zone trip impedances, such as travel times and travel costs.

improvement program, transportation—see *transportation improvement program*.

improvements, low-capital transportation—see *low-capital transportation improvements*.

inbound trip—see *trip, inbound*.

incentive—something that encourages people to act in a certain way. For example, free parking and automobiles provided by employers are incentives to automobile use.

incline—see *electric incline railway*.

inclined plane railway—a special type of tramway vehicle modified to run on rails so that its passenger seats remain horizontal while its undercarriage is angled parallel to the slope. It is used for steep gradients.

income elasticity—see *elasticity, income*.

incremental cost—see *cost, incremental*.

incremental trip assignment—see *trip assignment, incremental*.

independent variable—see *variable, independent*.

index, consumer price—see *consumer price index*.

indication, signal—see *signal indication*.

indication point—the point at which the train control or cab signal impulse is transmitted to the rail vehicle apparatus from the track element.

indicator, block—see *block indicator*.

indicator, performance—see *performance indicator*.

induced demand or traffic—see *traffic, induced*.

induction loop sensor—a loop of wire (inductor) embedded in the roadbed that carries a small electric current used to sense a passing vehicle and to yield information about the presence and velocity of the vehicle. Induction loops are also used to actuate traffic signals.

induction motor—see *motor, induction*.

inductive train control system—see *control system, continuous train*.

inductor—a track element consisting of a mass of iron, with or without a winding, that stimulates the train control, train stop, or cab signal mechanisms on the rail vehicle.

information, service or user—see *user information*.

information services—see *Highway Research Information Service, Railroad Research Information Service, Transportation Research Information Services, and Urban Mass Transportation Research Information Service*.

information system

management—see *management information system*.

market—see *market information system*.

Transportation Planning Support—see *Transportation Planning Support Information System*.

infrastructure—1. In transit systems, all the fixed components of the transit system, such as rights-of-way, tracks, signal equipment, stations, park-and-ride lots, bus stops, maintenance facilities. 2. In transportation planning, all the relevant elements of the environment in which a transportation system operates.

in kind—1. The intrinsic value of goods and services (work time, supplies, etc.) used to provide the required local participation for federal and state grants. 2. State or local funds required by the federal government to complement federal funds for a project; also known as *match* or *matching funds*. A match may also be required by states in funding projects that are a joint state and local effort.

input—information to be used in an analysis.

inside rail—see *rail, low*.

inside spread—see *spread, inside*.

inspection plate—the portion of the farebox on which coins and tickets land so that they may be seen by the operator.

inspector (road supervisor, route supervisor, street supervisor)—a transit employee who evaluates performance, enforces safety and work rules, and attempts to solve problems; an inspector may be mobile (covering several districts in a radio-equipped vehicle) or fixed (assigned to a post at a designated intersection).

Institute of Transportation Engineers—see *organizations, Institute of Transportation Engineers*.

instrument, track—see *track instrument*.

insulated rail joint—see *rail joint, insulated*.

integral structure (integral vehicle construction)—a vehicle in which the frame and body are built as one unit, so that all principal members are load bearing, as distinguished from body-on-chassis.

integration, intermodal—see *intermodal integration*.

interchange—1. The system of interconnecting ramps between two or more intersecting travel ways (highways, transit guideways, etc.) that are grade separated. 2. The transfer of rail cars from one railroad or transit agency to another so that they may be used by someone other than the owner.

interchange center, modal—see *transit center*.

intercity bus—see *bus, intercity*.

intercity transportation—1. Transportation between cities. 2. Transportation service provided between cities by certificated carriers, usually on a fixed route with a fixed schedule.

interface, transportation—see *transportation interface*.

Intergovernmental Review Process—U.S. Presidential Executive Order 12372 (July 14, 1982) requires federal agencies to use state and local processes of intergovernmental coordination for review of proposed federal financial assistance, state plans, direct development activities, and environmental documents. This procedure replaces *Circular A-95* procedures.

interline—in public passenger transportation, a term denoting the interchange of passengers between one or more bus lines, rail transit lines, or railroads.

interlocking—in rail systems, an arrangement of switch, lock, and signal devices that is located where rail tracks

cross, join, separate, and so on. The devices are interconnected in such a way that their movements must succeed each other in a predetermined order, thereby preventing opposing or conflicting train movements.

interlocking limits—the track length between the most remote opposing home signals of an interlocking.

intermodal—between or including more than one means or mode of transportation.

intermodal integration—service coordination between two or more different transportation modes. This arrangement may include joint (transfer) stations, coordinated scheduling, joint fares, and combined public information activities.

Intermodal Planning Group—see *U.S. Government, Intermodal Planning Group*.

intermodal transfer facility—see *transit center*.

internal combustion engine—see *engine, internal combustion*.

internal-internal trip—see *trip, internal-internal*.

International Taxicab Association—see *organizations, International Taxicab Association*.

International Union of Public Transport—see *organizations, International Union of Public Transport*.

intersection—the point at which two or more roadways meet or cross.

point of—see *point of intersection*.

Interstate Commerce Commission—see *U.S. Government, Interstate Commerce Commission*.

Interstate substitution transfer projects—transportation projects funded by monies that would otherwise have been spent on a segment of the Interstate highway system that has been eliminated. The funds must be spent in the same political jurisdiction as the eliminated segment.

interurban—see *transit system, interurban*.

intervening opportunities model—see *model, intervening opportunities*.

intervening time—see *time, intervening*.

interview, qualitative—see *qualitative interview*.

interzonal travel time—see *time, interzonal travel*.

interzonal trip—see *trip, interzonal*.

intrazonal travel time—see *time, intrazonal travel*.

intrazonal trip—see *trip, intrazonal*.

island, loading or pedestrian—see *loading island*.

iteration—strictly, a repeated process or operation. However, the term is almost always used to imply that the later repetitions make use of the results of, or are somehow modified by, the previous repetition.

J

JPA—joint powers agreement.

jerk—time rate of change of acceleration or deceleration of

a vehicle, measured in feet per second cubed (meters per second cubed).

jitney—a privately owned vehicle (typically, a relatively small vehicle, such as a small van) operated on a fixed route but not on a fixed schedule; see also *transportation system, jitney*; and *service, jitney*.

job description—a written statement of the elements of a particular job or occupation, such as purpose, duties, equipment used, chain of command, previous training required, physical and mental demands, working conditions.

job posting—a notice of available jobs, usually posted on a bulletin board so that applicants may bid for hire, promotion, or transfer.

joint, rail—see *rail joint*.

joint development (joint-use development)—1. In transportation, ventures undertaken by the public and private sectors for development of land above, below, or along transportation facilities. 2. Coordinated development of an area by the public sector and private enterprise.

joint operations—1. Rail operations conducted on a track used jointly or in common by two or more rail companies. 2. Operation of a train, locomotive, car, or other on-track equipment by one railroad over the track of another railroad.

joint powers agreement (JPA, joint powers agency, joint powers authority)—a voluntary association of government entities formed into a special purpose agency to deal with a common problem or problems, carry out a specific project, or provide a specific service, for example, the operation of a regional transit system.

joint-use corridor—a transportation right-of-way used for more than one mode of transportation, such as trains and automobiles; see also *area, multiple-use*.

journey, linked—see *trip, linked*.

journey time—see *time, journey*.

jumper, queue—see *queue jumper*.

jumper cable (jumper)—a flexible conductor or group of conductors arranged to connect electric circuits between adjacent vehicles or rails.

junction—1. In transit operations, a location at which transit routes or lines converge or diverge. 2. In traffic engineering, an intersection.

junction point—1. A location at which a rail branch line track connects with a main-line track. 2. A location at which two or more railroads interchange cars over connecting tracks. 3. A location at which several transit lines converge.

K

K&R—kiss and ride.

K factor—1. In a gravity or similar model, a travel constant that reflects intangible values and perceptions of the user,

for example, modal image, friendly service. 2. In vehicle operations, the ratio of the minimum operating separation between two vehicles to the maximum emergency stopping distance. Normally, the factor is greater than 1 to provide a margin of safety.

kilometer—For all terms containing “kilometer,” see equivalent term with “mile.”

kinetic energy—the energy of a body that results from its motion. The kinetic energy of a moving body is equal to the energy needed to bring it to rest.

kiss and ride (*kiss ‘n’ ride, K&R*)—An access mode to transit whereby passengers (usually commuters) are driven to a transit stop and left to board a transit unit and then met after their return trip. Transit stations usually provide a designated area for dropping off and picking up such passengers.

L

LCT—low-capital transportation improvements.

LEM—linear electric motor; see *motor, linear electric*.

LIM—linear induction motor; see *motor, linear induction*.

LOS—level of service.

LRE—long-range element.

LRRT—light rail rapid transit; see *transit system, light rail rapid*.

LRT—light rail transit; see *transit system, light rail*.

LRV—light rail vehicle; see *car, light rail*.

LSM—linear synchronous motor; see *motor, linear synchronous*.

labor turnover—the movement of workers into and out of employment in a company or industry through hiring, layoffs, recall, resignations, and so on. The rate of labor turnover is usually expressed as the number of accessions and separations during a given period per 100 employees.

labor union—see *union*.

land use—the purpose for which land or the structure on the land is being used, for example, residential, commercial, light industry.

land use model—see *model, land use*.

lane—a portion of a street or highway, usually indicated by pavement markings, that is intended for one line of vehicles.

bicycle—a portion of a roadway or right-of-way that has been designated for preferential or exclusive use by bicycles. It is distinguished from the rest of the roadway by a painted stripe, curb, or other similar device. See also *bicycle route*.

bus (*bus priority lane, preferential bus lane, priority bus lane*)—a highway or street lane reserved primarily for buses, either all day or during specified periods. It may be used by other traffic under certain circumstances, such as

lane (*continued*)

making a right or left turn, or by taxis, motorcycles, or carpools that meet specific requirements described in the traffic laws.

bypass—see *queue jumper*.

carpool—a highway or street lane intended primarily for carpools, vanpools, and other high-occupancy vehicles, either all day or during specified periods. It may be used by other traffic under certain circumstances, such as while making a right turn.

contraflow—a highway or street lane on which vehicles operate in a direction opposite to what would be the normal flow of traffic in that lane. Such lanes may be permanently designated contraflow lanes, or, more usually, they may be used as contraflow lanes only during certain hours of the day. Frequently, the use of a contraflow lane is restricted to public transit and (possibly) other specially designated vehicles.

diamond—a high-occupancy-vehicle lane physically marked by diamonds painted on the pavement and often indicated by diamond-shaped signs as well.

exclusive carpool—a highway or street lane reserved for carpools and vanpools.

exclusive transit (*reserved transit lane*)—a highway or street lane reserved for buses, light rail vehicles, or both.

high-occupancy-vehicle (*HOV lane*)—a highway or street lane reserved for the use of high-occupancy vehicles (HOVs).

preferential bus—see *lane, bus*.

priority—a highway or street lane reserved (generally during specified hours) for one or more specified categories of vehicles, for example, buses, carpools, vanpools.

priority bus—see *lane, bus*.

ramp meter bypass—a form of preferential treatment in which a bypass lane on metered freeway on-ramps is provided for the exclusive use of high-occupancy vehicles.

reserved transit—see *lane, exclusive transit*.

reversible—a highway or street lane on which the direction of traffic flow can be changed to use maximum roadway capacity during peak-period demands.

reversible bus—a highway or street lane that is reserved for the exclusive use of buses and other high-occupancy vehicles and that can be operated in alternate directions during the two peak-hour periods. It may be the center lane in an arterial street that is used for left-turning traffic in off-peak hours. Usually, bus operators who use this facility are required to have special training and a permit, and the buses may be subject to access or operation controls or both.

latent travel demand—see *travel demand, latent*.

lateral motion—in rail operation, motion crosswise of the path of travel that results from the flexibility that must be provided in the track structure to permit its negotiation. It is experienced by all rail car parts except the wheels and axles. Lateral motion may also occur when the wheel tread is worn

to a dished profile. This type of wear causes truck hunting at speed and hence produces lateral motion.

law, full crew—see *full crew law*.

lay-by—1. In rail systems, a side track. 2. In bus systems, see *bus bay*.

layoff—the involuntary separation of a worker from employment, usually for a temporary or indefinite period, without prejudice toward the worker.

layoff allowance—see *pay, severance*.

layout sheet, terminal—see *sheet, terminal layout*.

layover, vehicle—see *time, layover*.

layover time—see *time, layover*.

layover zone—a designated stopover location for a transit vehicle at or near the end of the route or line or at a turnback point.

lead agency—under the National Environmental Policy Act of 1969, the public agency that has the principal responsibility for preparing environmental documents and for carrying out or approving a project that may have a significant effect on the environment.

leader run—see *run, leader*.

legislation

National Environmental Policy Act of 1969 (NEPA)—a comprehensive federal law requiring an analysis of the environmental impacts of federal actions, such as the approval of grants, and the preparation of an environmental impact statement for every major federal action that significantly affects the quality of the human environment.

Section 3—the section of the Urban Mass Transportation Act of 1964, as amended, that enables the Secretary of Transportation to make grants or loans to states and local public entities to finance specific types of public transportation projects. Although the grants are discretionary, Congress can and does earmark funds for specific projects. Section 3 funds are usually divided among rail modernization, new rail starts, bus, planning, and other projects, including elderly and handicapped transportation.

Section 9—the section of the Urban Mass Transportation Act of 1964, as amended, that governs the distribution of the public transit and capital and operating block grant appropriations, made by Congress each year, among transit operators across the nation.

Section 13(c)—the section of the Urban Mass Transportation Act of 1964, as amended, that requires that as a condition of any assistance under the act, fair and equitable arrangements must be made to protect the interests of employees affected by such assistance, including but without being limited to continuation of collective bargaining rights; preservation of rights, privileges, and benefits under existing collective bargaining agreements or otherwise; protection of individual employees against a worsening of their position with respect to their employment; assurance of employment to employees of acquired mass transportation systems and priority of reemploy-

legislation (continued)

ment for those terminated or laid off; and paid training programs.

Section 15—the section of the Urban Mass Transportation Act of 1964, as amended, that authorizes the Secretary of Transportation to request and receive statistical information about the financing and operations of public mass transportation systems on the basis of a uniform system of accounts and records.

Section 16(b)(2)—the section of the Urban Mass Transportation Act of 1964, as amended, that authorizes the Secretary of Transportation to award capital grants to private nonprofit organizations and associations that provide transportation services to elderly and handicapped individuals.

Section 18—the section of the Urban Mass Transportation Act of 1964, as amended, that governs the allocation of funding for public transit in nonurbanized areas.

Section 504—the section of the Rehabilitation Act of 1973 that established the policy that otherwise qualified handicapped people may not be discriminated against in any federal or federally assisted program.

Urban Mass Transportation Act of 1964—federal legislation enacted in 1964 that established the federal mass transportation program. There have been periodic amendments to the act since it was passed.

level of service (LOS)—1. A set of characteristics that indicate the quality and quantity of transportation service provided, including characteristics that are quantifiable (*system performance*, e.g., frequency, travel time, travel cost, number of transfers, safety) and those that are difficult to quantify (*service quality*, e.g., availability, comfort, convenience, modal image). 2. For highway systems, a qualitative rating of the effectiveness of a highway or highway facility in serving traffic, in terms of operating conditions. The *Highway Capacity Manual* identifies operating conditions ranging from A, for best operation (low volume, high speed), to F, for worst conditions. 3. For paratransit, a variety of measures meant to denote the quality of service provided, generally in terms of total travel time or a specific component of total travel time. 4. For pedestrians, sets of area occupancy classifications to connect the design of pedestrian facilities with levels of service (A for best through F for worst). 5. For transit rights-of-way, see *right-of-way*.

levitated vehicle—see *vehicle, tracked levitated*.

levitation, magnetic—see *magnetic levitation*.

license plate survey—see *survey, license plate*.

life, useful—see *useful life*.

life cycle costing—a method of evaluation of alternative choices (e.g., vehicles) on the basis of comparative total costs for purchase and operations over the expected useful life of the asset.

life cycle procurement—a form of competitive procurement in which the contract is awarded on the basis of a consideration of cost of operation over a designated term of

life as well as initial capital cost; see also *low bid procurement*.

lift, wheelchair—see *wheelchair lift*.

light rail—see *transit system, light rail*; and *transit system, light rail rapid*.

light rail car—see *car, light rail*.

light rail rapid transit—see *transit system, light rail rapid*.

light rail transit—see *transit system, light rail*.

light rail vehicle—see *car, light rail*.

limit, civil speed—see *civil speed limit*.

limited access—see *access, limited*.

limited or limited stop service—see *service, limited*.

limits, interlocking—see *interlocking limits*.

limits, yard—see *yard limits*.

limousine service—see *service, limousine*.

line—1. A transportation company (e.g., a bus line). 2. A transit service operated over a specified route or combination of routes. 3. An active (in-use) railroad track or AGT guideway. 4. In network coding, a route and its service level, including mode designation (type of service), line number, headway, and sequence of transfer points (nodes). These factors describe the line's route as an ordered set.

branch—a line of track branching off from the main line to provide service to an area not served directly by the main line itself.

cordon—see *cordon line*.

cut—see *cut line*.

desire—see *desire line*.

double-track main—a rail main line that has two tracks, usually one for each direction.

gauge—see *gauge line*.

main—the principal roadway, rail tracks, or other types of transportation rights-of-way over which all or most of the traffic moves.

screen—see *screen line*.

single-track main—a rail main line that has one track. It requires passing sidings for bidirectional operation.

linear electric motor—see *motor, linear electric*.

linear induction motor—see *motor, linear induction*.

linear synchronous motor—see *motor, linear synchronous*.

line capacity—see *capacity, line*; and *capacity, theoretical line*.

line circuit, electric train—see *electric train line circuit*.

line haul—see *service, line haul*.

line miles (line kilometers, miles or kilometers of directional roadway)—the sum of the actual physical length (measured in only one direction) of all streets, highways, or rights-of-way traversed by a transportation system (including exclusive rights-of-way and specially controlled facilities), regardless of the number of routes or vehicles that pass over any of the sections; see also *route miles*.

line volume—see *passenger volume*.

link—in planning, a section of a transportation system net-

work defined by intersection points (nodes) at each end; that is, a link connects two nodes. It may be one way or two way.

link analysis—see *selected link analysis*.

linked journey or trip or passenger trip—see *trip, linked*.

linked trip distance—see *trip distance, linked*.

linked trip time—see *time, linked trip*.

link load—in planning, the assigned volume of traffic on a link; see also *link volume*.

link loading—in planning, the process of determining the link loads by selecting routes of travel and accumulating the trip volumes on each link that is traversed.

link volume—in planning, the total number of highway vehicles or transit passengers assigned to a network link.

livery service—see *service, limousine*.

load, crush—see *capacity, crush*.

load, link—see *link load*.

load, passenger—see *passenger load*.

load factor—1. The ratio of used capacity to offered capacity of equipment or a facility during a specified time period. It is usually expressed as a percentage of seats occupied at a given point or (in continuous form) passenger miles (kilometers) divided by seat miles (kilometers). For rail services, the load factor is sometimes expressed as passenger miles (kilometers) per train mile (kilometer) to account for the ability to couple rail cars together to achieve efficiency. 2. The ratio of passengers actually carried versus the total passenger capacity of a vehicle; also known as a *utilization coefficient*.

loading, link—see *link loading*.

loading island—1. A pedestrian refuge within the right-of-way and traffic lanes of a highway or street. It is provided at designated transit stops for the protection of passengers from traffic while they wait for and board or alight from transit vehicles; also known as a *pedestrian island*. 2. A protected spot for the loading and unloading of passengers. It may be located within a rail transit or bus station.

load point, maximum—see *maximum load point*.

load section, maximum—see *maximum load section*.

load shedding—reducing the amount of conventional transit service at peak hours by encouraging the use of paratransit operations to carry some of the peak-period passengers.

local access street—see *street, local access*.

local bus or service—see *service, local bus*.

local train—see *train, local*.

location, vehicle—see *automatic vehicle location system*.

locked switch, electrically—see *switch, electrically locked*.

locking—in rail systems, the electrical or mechanical establishment of a condition for a switch, interlocking route, speed limit, or automatic function that cannot be altered except by a prescribed and inviolate sequence of unlocking actions.

locomotive—a powered rail vehicle used for towing rail cars. It does not carry passengers and is usually powered by electric motors or diesel engines.

locomotive (*continued*)

diesel-electric—a locomotive that uses one or more diesel engines to drive electric generators that in turn supply electric motors geared to the driving axles. Speed is controlled by controlling the output of the electric motors.

diesel-hydraulic—a locomotive in which power from one or more diesel engines is delivered through hydraulic transmission to the driving axles by means of shafts and gears. The hydraulics are for speed control.

dual-powered—a locomotive that is capable of both diesel and electric operation.

electric—a locomotive in which the propulsion is effected by electric motors mounted on the vehicle. The electric power comes from an external source.

gas turbine—a locomotive in which power developed by a turbine drives electric generators that supply traction power through electric motor gear drives. It usually burns oil.

passenger—a locomotive commonly used for hauling passenger trains and generally designed to operate at higher speeds and lower tractive effort than a freight locomotive of equal power.

self-propelled—a locomotive that requires no external source of electric power for its operation.

logo—a distinctive emblem, symbol, or trademark that identifies a product or service.

long-range element (LRE)—as provided in FHWA-UMTA joint regulations governing transportation programming, the LRE of a transportation plan provides for the long-range transportation needs of the urbanized area and identifies new transportation policies and facilities or major changes in existing facilities. It must be consistent with the area's comprehensive long-range land use plan, urban development objectives, and overall social, economic, environmental, system performance, and energy conservation goals and objectives.

loop—1. A transit route or guideway layout that is of a closed continuous form, such as a circle. 2. A terminal track layout or bus driveway that reverses the direction of a vehicle without the vehicle's reversing.

induction—see *induction loop sensor*.

pinched—a collapsed loop layout on which vehicles in both directions are reversed at the ends. The reversing layout is such that both lanes are merged into one; that is, at the pinched point the same or adjacent travel ways would be traversed.

low bid procurement—a form of competitive procurement in which the contract is awarded on the basis of the lowest price bid for the services or goods rendered; see also *life cycle procurement*.

low-capital alternative—see *transportation system management alternative*.

low-capital transportation improvements (LCT, low-capital intensive transportation improvements)—a group of transportation improvements, designed to increase the

usefulness of existing transportation facilities, that generally cost less and can be implemented more quickly than system development actions; see also *transportation system management*.

low mobility group—see *transportation disadvantaged*.

low platform—see *platform, low*.

low rail—see *rail, low*.

low voltage—see *voltage, low*.

M

MAC—major activity center.

MAC system—major activity center system; see *transit system, major activity center*.

MAGLEV—magnetic levitation.

MBE—minority business enterprise.

MIS—management information system.

MLP—maximum load point.

MLS—maximum load section.

MPO—metropolitan planning organization; see *organizations, metropolitan planning organization*.

MR—motivational research.

MSA—metropolitan statistical area; see *area, metropolitan statistical*.

MU—multiple unit; see *car, multiple-unit*.

machine, ground effect—see *vehicle, air cushion*.

magnetic brake—see *brake, track*.

magnetic coupling—see *coupling, magnetic*.

magnetic farecard—a card containing a magnetic tape strip or other electronic means of indicating the value purchased. The card is usually obtained from a vending machine and must be inserted into a farecard reader to gain access to the paid area of the transit system. In some systems, the card must also be inserted into a farecard reader to exit the paid area.

magnetic levitation (MAGLEV)—support technology that keeps a vehicle vertically separated from its track or riding surface by magnetic force, either attractive or repulsive.

main line—see *line, main*.

maintenance—the upkeep of vehicles, plant, machinery, and equipment. It may be scheduled, planned, progressive, or periodic on the basis of preestablished intervals of time, hours, or mileage, and employ preprinted checklists (*preventive maintenance*), or it may be unscheduled or corrective, in which case it is generally not interval based.

major activity center (MAC, activity center)—a geographical area characterized by a large transient population and heavy traffic volumes and densities; for example, central

business district, major air terminal, large university, large shopping center, industrial park, sports arena.

major activity center transit system—see *transit system, major activity center*.

major street—see *street, major*.

makeup time—see *time, pad*.

management

headway—see *headway management*.

marketing—see *marketing management*.

risk—see *risk management*.

transportation system—see *transportation system management*.

✓ **management information system (MIS)**—a system (manual or computerized) by which financial and operating data are collected and analyzed for management's use.

manual block control system—see *control system, manual block*.

manual train control—see *control system, manual train*.

many-to-few service—see *service, many-to-few*.

many-to-many service—see *service, many-to-many*.

many-to-one service—see *service, many-to-one*.

map, flow—see *flow map*.

marginal cost—see *cost, marginal*.

marker—a front or rear signal of a train (flag, reflector, or lamp).

market—1. The potential or actual consumers (or both) of a (transportation) product or service. A general market denotes the entire population of a designated geographical area, whereas a specialized market denotes particular groups, such as the elderly, handicapped, students. 2. The extent of demand for a (transportation) commodity or service.

target—a specified segment of the potential or actual (transportation) market (or both) that has been analyzed and selected by a (transportation) provider so that a marketing mix (target marketing) can be directed toward this segment.

market analysis—a type of marketing research that involves the measurement of the extent of present (transportation) needs, the determination of their characteristics, and the projection of future trends.

market information system—a systematic approach to providing (transportation) decision makers with relevant marketing information on a continuing basis.

marketing—1. A comprehensive process to induce greater usage of (transportation) services or products by determining the needs or demands of the community and potential consumers, developing and implementing services on the basis of these needs, pricing the services, promoting the services, and evaluating the services as implemented in relation to consumer needs and marketing goals. 2. In some organizations the marketing function is defined more narrowly as market research, pricing (fare) structure, image development (e.g., logo and color scheme), information services (e.g., route maps and schedules), advertising, and promotional efforts.

marketing concept—a philosophy that marketing is a management function that links the organization with its external environment (consumers and other constituencies). It includes responding to needs and anticipating change by attention to the process by which people adopt, maintain, or discard ideas, beliefs, or behavior patterns.

marketing cost analysis—the classification of accounting data into functional accounts (accounts organized by the purpose for which the expenditure was made or for which the revenue was received) instead of the traditional natural accounts (e.g., salaries and supplies) so that the marketer can evaluate the potential revenue and profitability of particular customers, territories, and so on.

marketing management—the planning, organizing, direction, and control of the entire marketing activity of a (transportation) supplier, including the formulation of marketing strategy, objectives, policies, and programs, market research, and product development; organization and staffing to carry out plans; supervision of marketing operations; and control of marketing performance.

marketing mix—the four basic elements in a marketing program that influence consumer decisions: product, pricing, distribution or delivery, and communication (promotion).

marketing planning—the process of setting up objectives for marketing activity and of determining and scheduling the steps necessary to achieve such objectives.

marketing research—the systematic gathering, recording, and analyzing of primary (newly collected) and secondary (existing) data to provide information for marketing decision making. In transportation, this could consist of gathering information and data (including economic data, etc.) and analyzing this material to identify the service attributes that most strongly influence the decisions of different groups about travel, to assess the potential demand for transportation, to determine the characteristics (needs, numbers, etc.) of potential users of a system, and to anticipate future trends.

market outline—a summary of the relative position of a type of (transportation) product or service in the total (transportation) market.

market potential—a calculation of the maximum possible number of buyers or users of a (transportation) good or service in a defined territorial area during a stated time period.

market profile—a description of the characteristics of people (age, sex, income, etc.) or of businesses or industrial activity (size, volume of sales, etc.) that constitute the market for a (transportation) product or service.

market segment—a portion of the population or a commercial activity consisting of individuals that have similar socioeconomic, demographic, economic, or other characteristics, so that similar marketplace behavior can be implied. The market segment may require a marketing plan tailored to its distinctive characteristics.

market segmentation—the process of identifying market segments.

market share—the percentage of a (transportation) market realized by or available to a particular (transportation) provider.

markings, pavement—see *pavement markings*.

mark-up—see *sign-up*.

bus—see *sheet, booking*.

driver—see *sheet, assignment*.

married pair—two semipermanently coupled rail cars (A car and B car) that share some mechanical and electrical equipment and must be operated together as a unit.

mass transit—see *public transit*.

mass transportation—transportation by bus, rail, boat, or other conveyance, either publicly or privately owned, that provides general or special service to the public on a regular and continuing basis (not including school bus, charter, or sightseeing service).

match or matching funds—see *in kind*.

matrix—an array of symbols or numbers, called elements, arranged in rows and columns in two dimensions and used as a form of tabulation.

impedance—see *impedance matrix*.

trip—see *trip matrix*.

maximum load point (MLP)—the point on a transit line or route at which the passenger volume is the greatest. There is one maximum load point in each direction.

maximum load section (MLS)—the section of a transit line or route that carries the highest total number of passengers for that line or route and direction.

maximum service braking—see *braking, maximum service*.

maximum spread—see *spread, maximum*.

maximum theoretical velocity—see *velocity, maximum theoretical*.

measure of effectiveness—see *performance indicator*.

mechanical brake—see *brake, friction*.

median (median strip)—the portion of a divided highway or guideway that separates the opposing flows of traffic.

merchandising—the planning and supervision involved in marketing the particular product or service at the places, times, and prices and in the quantities that will best realize the marketing objectives of the suppliers.

merge point—the section of a guideway or roadway at which two lines or lanes converge to become one.

messenger—see definition of *catenary system*.

metered freeway—see *freeway, metered*.

metered freeway bus priority system—see *bus priority system, metered freeway*.

metering, ramp—see *ramp metering*.

method, Delphi—see *Delphi process*.

metro—see *transit system, rail rapid*.

metropolitan planning organization—see *organizations, metropolitan planning organization*.

metropolitan railway—see *transit system, rail rapid*.

metropolitan statistical area—see *area, consolidated metropolitan statistical; area, metropolitan statistical; area, primary metropolitan statistical; and area, standard metropolitan statistical*.

midblock stop—see *stop, midblock*.

midibus—a bus with a passenger capacity of approximately 20–30 people.

mileage, block—see *block mileage*.

mileage fare—see *fare, graduated*.

miles of directional roadway—see *line miles*.

miles of route or roadway—see *route miles*.

miles of travel, vehicle—see *vehicle miles of travel*.

minibus—a small bus, typically capable of carrying 20 passengers or fewer. It is most often used for making short trips, demand-responsive transportation, or buspools.

minimum path—the route of travel between two points that has the least accumulation of time, distance, or other impedance measure.

minority business enterprise (MBE)—for transportation activities, a business owned and controlled by one or more individuals who are defined as minorities under U.S. Department of Transportation regulations for federally financed projects or by the appropriate state agency for state financed projects; see also *disadvantaged business enterprise*.

miss-out—a situation in which an operating employee fails to report for work on time without notifying the employer.

mix, marketing—see *marketing mix*.

mixed mode street—see *street, mixed mode*.

mixed or mixed flow traffic—see *traffic, mixed*.

mixed traffic operations—the operation of transit vehicles on nonexclusive rights-of-way (transit ROW category C) with nontransit vehicles.

modal interchange center—see *transit center*.

modal split (mode split)—1. The proportion of total person trips that uses each of various specified modes of transportation. 2. The process of separating total person trips into the modes of travel used; see also *urban transportation modeling system and model, sequential*. 3. A term that describes how many people use alternative forms of transportation. It is frequently used to describe the percentage of people who use private automobiles, as opposed to the percentage who use public transportation.

mode—a particular form of travel, for example, walking, traveling by automobile, traveling by bus, traveling by train.

access—a feeder mode to the principal mode of transportation; for example, walking, kiss and ride, park and ride.

dual—see *transit system, dual-mode*.

transit—a category of transit systems characterized by common characteristics of technology, right-of-way, and type of operation. Examples of different transit modes are regular bus service, express bus service, light rail transit, rail rapid transit, and commuter rail.

model—1. A mathematical or conceptual presentation of relationships and actions within a system. It is used for

model (*continued*)

analysis of the system or its evaluation under various conditions; examples include land use, economic, socioeconomic, transportation. 2. A mathematical description of a real-life situation that uses data on past and present conditions to make a projection about the future.

abstract choice—a model based on the assumption that it is not necessary to identify travel choice variables by the name of their mode, destination, time of day, or other characteristics; instead, they are identified by their attributes, for example, variables describing level of service.

activity allocation—a model used to predict the geographical distribution of land use activities.

aggregate demand—a model calibrated by combining observations of travel by individuals into geographic or demographic units that are used to estimate new flows when service attributes or unit sizes change.

binary choice—a demand model used in trip generation and modal choice that is based on the assumption that travelers make one of two possible choices.

demand (*demand-forecasting model*)—a model that relates the amount of travel to the level and price of the transportation service and the socioeconomic characteristics of the potential traveler.

deterministic—a model that expresses the interaction of system elements with complete certainty, that is, as absolute values.

direct demand—a model that simultaneously (in a single equation) predicts all travel choices for aggregate groups of individuals.

disaggregate demand—a model that is calibrated by using the observations of the travel choice behavior of individuals directly and is usually set up as a probabilistic model.

four-stage—see *urban transportation modeling system*.

Fratar (*Fratar distribution*)—a method of extrapolating a given distribution of trips on the basis of growth factors for the origin and destination ends. It is named after Thomas J. Fratar, the developer.

general share—a model that estimates a share of trips, such as a mode share of all trips or a destination share of trips from a given origin.

gravity—a mathematical trip distribution model that is based on the premise that the amount of travel between two zones is proportional to the amount of activity in each of the two zones and inversely proportional to the impedance to travel between the two zones. In other words, trips produced in any given area will distribute themselves in accordance with the accessibility of other areas and the opportunities.

intervening opportunities—a mathematical model that is based on probability theory and that distributes trips from one zone to each other zone in proportion to the probability that the trips have not found a prior destination in zones ranked closer to the zone of origin.

land use—a model used to predict the future spatial allocation of urban activities (land use), given total regional growth, the future transportation system, and other factors.

model (*continued*)

mode choice (*modal choice model*)—a model used to forecast the proportion of total person trips on each of the available transportation modes.

multiple-choice—a model that relaxes the assumption of only two possible choices and allows any number of possible choices within a given level of travel choice, such as mode, route, or time period, or among any or all of these trip characteristics.

probabilistic—in transportation modeling, a model whose basic premise is that travel flows cannot be predicted with certainty and uses probabilities in its algorithm, as part of its output statement, or elsewhere.

regional growth—a model used to estimate land uses in a region.

sequential—a demand model that is based on the assumption that travel decisions are made in a sequence of steps, such as whether or how often to travel (trip generation), what destination to choose (trip distribution), which mode to choose (modal split), and which route to choose (trip assignment).

share—a demand-forecasting model that divides a trip total (such as total trips from an origin) into its various components (such as trips from the origin to each of the destinations).

simulation—a model that represents mathematical events and responses to these events in a manner that resembles the interaction of cause and effect in a real system.

simultaneous—a demand-forecasting model that is based on the assumption that travelers choose a level of trip frequency, time of day, destination, mode, and path as a single decision and that in making this decision, travelers consider the alternatives for each of these choices simultaneously.

traffic—a mathematical equation or graphic technique used to simulate traffic movements, particularly those in urban areas or on a freeway.

modeling system, urban transportation—see *urban transportation modeling system*.

mode or modal choice model—see *model, mode choice*.

mode split—see *modal split*.

monitoring, vehicle—see *automatic vehicle monitoring system*.

monobeam—a type of guideway that consists of a single beam, usually elevated. It generally has a rectangular cross section that is usually straddled by the associated vehicles.

monorail—see *transit system, monorail*.

Monte Carlo technique—a simulation technique in which a random number generator is used to assign the numerical values of some components in the system being analyzed. It is usually assumed that a large number of repetitions of the simulation will produce reliable data on the means and distributions of the outputs.

monthly pass—see *pass, monthly*.

Moore's algorithm—a numerical procedure for determining the shortest paths from a single starting node to each other node in a network.

motion, lateral—see *lateral motion*.

motivational research (MR)—research that attempts to relate behavior to underlying desires, emotions, and intentions instead of merely enumerating behaviors or describing a situation. It relies heavily on the use of techniques adapted from psychology and other social sciences.

motor (electric motor)—a machine that transforms electrical energy into mechanical energy (torque).

alternating-current—an electric motor (synchronous, induction, etc.) that operates on alternating current.

asynchronous—an asynchronous machine that transforms electrical power from any alternating-current system into mechanical power and whose rotor does not turn at synchronous speed.

compound—a direct current motor that has two separate field windings, one (usually the predominating field) connected in parallel with the armature circuit and the other connected in series with the armature.

direct current—an electric motor (shunt, compound, etc.) that operates on direct current.

double-sided linear induction (DLM, DSLM)—a linear induction motor that has its active primary winding constructed so that it reacts magnetically with both sides of the guideway-mounted reaction rail (secondary winding).

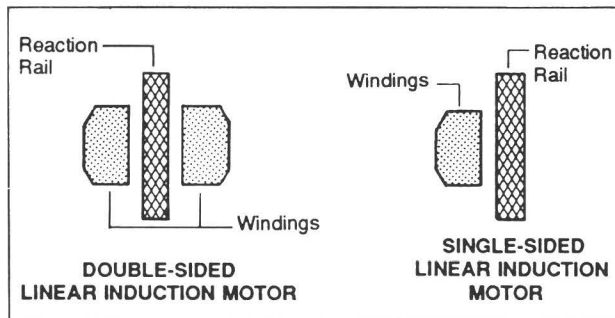

electric—see *motor*.

induction—an asynchronous alternating-current motor that converts alternating-current electric power, delivered to the primary winding (usually the stator) and carried as induced current by the secondary winding (usually the rotor), into mechanical power; see also *motor, linear induction*.

linear electric (LEM)—an electric motor that produces mechanical force through linear, instead of rotary, motion. It is chiefly used for propelling vehicles along a track or other guideway.

linear induction (LIM)—an asynchronous linear alternating-current motor composed of a winding in the guideway and a winding in the vehicle, one of which is energized to produce opposing magnetic fields that propel by alternately attracting and repelling the vehicle; see also *motor, double-sided linear induction*; and *motor, single-sided linear induction*.

linear synchronous (LSM, synchronized linear

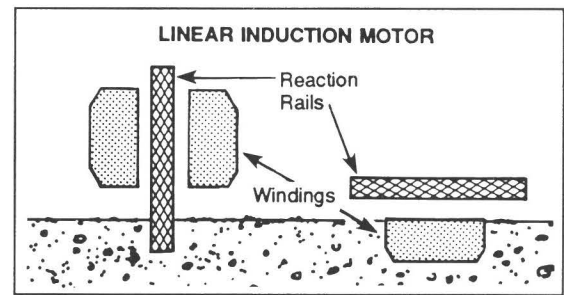

motor (continued)

motor—a synchronous linear alternating-current motor that supplies fixed speed operation for the powered vehicle. The fixed speed can be controlled electronically.

series-wound—a motor in which the field circuit is connected in series with the armature circuit. It is also often called a *traction motor*.

shunt—a type of rotary electric motor in which the field coils are connected in parallel with the motor armature.

single-sided linear induction (SLM, SSLM)—a linear induction motor that has a single primary winding on one side of the secondary or reaction rail.

synchronous—a synchronous machine that transforms electrical power from any alternating-current system into mechanical power. The average speed of normal operation is equal to the frequency of the power system to which it is connected. See also *motor, linear synchronous*.

traction—an electric motor, usually direct current and series wound, that propels a vehicle by exerting its torque through the wheels; see also *motor, series-wound*.

motor brake—see *brake, dynamic*.

motor bus—see *bus, motor*.

motor car, rail—see *car, rail motor*.

motor coach—see *bus, motor*.

motor operator or motorman—see *operator, train*.

motorway—see *freeway*.

move, reverse—see *reverse move*.

mover, people—see *people mover*.

moving block control system—see *control system, moving block*.

moving point control system—see *control system, moving slot*.

moving ramp—see *ramp, moving*.

moving sidewalk—see *moving walkway*.

moving slot control system—see *control system, moving slot*.

moving walkway (moving sidewalk, passenger or pedestrian conveyor, passenger belt)—a fixed conveyor device (usually a flexible belt) on which pedestrians may stand or walk while being transported; see also *ramp, moving*.

multimodal—concerning or involving more than one transportation mode.

multiple-choice model—see *model, multiple-choice*.

multiple-unit car—see *car, multiple-unit*.

multiple-unit control system—see *control system, multiple-unit*.

multiple-use area—see *area, multiple-use*.

N

NACo—National Association of Counties; see *organizations, National Association of Counties*.

NARC—National Association of Regional Councils; see *organizations, National Association of Regional Councils*.

NCHRP—National Cooperative Highway Research Program.

NCTRP—National Cooperative Transit Research and Development Program.

NEPA—National Environmental Policy Act; see *legislation, National Environmental Policy Act of 1969*.

NLC—National League of Cities; see *organizations, National League of Cities*.

NPTS—Nationwide Personal Transportation Study.

NTSB—National Transportation Safety Board; see *U.S. Government, National Transportation Safety Board*.

narrow gauge—see *gauge, narrow*.

National Association of Counties—see *organizations, National Association of Counties*.

National Association of Regional Councils—see *organizations, National Association of Regional Councils*.

National Cooperative Highway Research Program (NCHRP)—a program established by the American Association of State Highway Officials (now American Association of State Highway and Transportation Officials) to provide a mechanism for a national coordinated program of cooperative research employing modern scientific techniques. NCHRP is administered by the Transportation Research Board.

National Cooperative Transit Research and Development Program (NCTRP)—a program established under Section 6(a) of the Urban Mass Transportation Act of 1964, as amended, to provide a mechanism by which the principal client groups of the Urban Mass Transportation Administration can join cooperatively in an attempt to resolve near-term public transportation problems through applied research, development, testing, and evaluation. NCTRP is administered by the Transportation Research Board.

National Environmental Policy Act of 1969—see *legislation, National Environmental Policy Act of 1969*.

National League of Cities—see *organizations, National League of Cities*.

national product deflator, gross—see *gross national product deflator*.

National Railroad Passenger Corporation—see *U.S. Government, National Railroad Passenger Corporation*.

National Transportation Safety Board—see *U.S. Government, National Transportation Safety Board*.

Nationwide Personal Transportation Study (NPTS)—the NPTS, conducted (at this time) in 1969, 1977, and 1983 by the Bureau of the Census, has been the primary source of national data on travel patterns and frequency, transit use for all purposes, and the characteristics of transit users versus all travelers.

near-side stop—see *stop, near-side*.

needs assessment—in transportation planning, a technique of estimating the services and facilities needed to satisfy the potential demand for transportation service.

network—1. In planning, a system of links and nodes that describes a transportation system. 2. In highway engineering, the configuration of highways that constitutes the total system. 3. In transit operations, a system of transit lines or routes, usually designed for coordinated operation.

composite—in planning, a group of interconnected lines that represents a multimodal combination of existing and proposed transportation facilities and routes. It is often used for simulating travel patterns and determining capacities or other transportation system characteristics.

grid—1. In planning, an imaginary network of evenly spaced horizontal and vertical bars or lines that divides a study area into small geographic zones. 2. In transit operations, a service pattern in which two sets of parallel routes intersect each other at right angles.

radial—in transit operations, a service pattern in which most routes converge into and diverge from a central hub or activity center (e.g., central business district), like the spokes of a wheel. The hub may serve as a major transfer point.

simplified—see *network, spiderweb*.

spiderweb (spider network, simplified network)—a simulated highway system for a given area that is composed only of connections between zone centroids without respect to the physical street layout. It is usually used for corridor analysis.

network coding—the process of abstracting details of a real transportation network and recording them in a form suitable for computer processing.

network control—see *control system, asynchronous network; control system, quasi-synchronous network; and control system, synchronous network*.

New Look bus—see *bus, New Look*.

night shift—see *shift, night*.

no-action alternative (do-nothing alternative, null alternative)—a planning option of leaving the situation as it already exists. Existing facilities and services are maintained, and existing transportation policies are continued. See also *transportation system management alternative*.

no-build alternative—see *transportation system management alternative*.

node—in planning, a point that represents an intersection of two or more links, highways, or transit lines or routes or a zone centroid; used in trip assignment.

nonambulatory handicapped—see *handicapped, nonambulatory*.

non-home-based trip—see *trip, non-home-based*.

nontransportation revenue—see *revenue, nontransportation*.

normal vehicle capacity—see *capacity, vehicle*.

nosing—a transverse, horizontal motion of a locomotive that exerts a lateral force on the supporting structure.

not-in-service time—see *time, deadhead*.
null alternative—see *no-action alternative*.



OBD—outlying business district.
O-D study—origin-destination study.
OMB—Office of Management and Budget; see *U.S. Government, Office of Management and Budget*.
OTA—Office of Technology Assessment; see *U.S. Government, Office of Technology Assessment*.

objective—1. A measurable, attainable, and desired level of achievement of a goal, including the time span within which it is to be achieved and the person or people responsible for the achievement. An objective reflects established priorities and falls within constraints set by policy. 2. A specific step toward the attainment of a goal.

objectives, pricing—see *pricing objectives*.

occupancy

area—see *area occupancy*.

vehicle—see *vehicle occupancy*.

off, time—see *time off*.

off book—a list of transit operators who have asked to be excused from work on a specific day.

off-day board—see *operators' off-day board*.

off days—an employee's scheduled time off.

Office of Management and Budget—see *U.S. Government, Office of Management and Budget*.

Office of Technology Assessment—see *U.S. Government, Office of Technology Assessment*.

off-line—not in the main flow of traffic or not on the main line of traffic, for example, off-line station.

off-line station—see *station, off-line*.

off peak—the periods of time outside the peak periods; see also *base period*.

off-peak fare—see *fare, time-of-day*.

off-peak period—see *base period*.

offset—1. In transit operations, the amount of time (system-wide) that the train control computer has added into the theoretical schedule to maintain proper train sequencing, scheduled connections, and headways. 2. In traffic operations, the time difference between traffic signals as measured from some reference point.

off-street terminal—see *terminal, off-street*.

on, time—see *time on*.

on-and-off check or count—see *check*.

on-board check—see *check*.

102 statement—see *environmental impact statement*.

one-piece run—see *run, one-piece*.

one-to-many service—see *service, one-to-many*.

one-way trip—see *trip*.

one-zone ride—a transit ride within the limits of one fare zone.

on-line—in the main flow of traffic.

on-line station—see *station, on-line*.

on-time performance—the proportion of the time that a transit system adheres to its published schedule times within stated tolerances; for example, a transit unit (vehicle or train) arriving, passing, or leaving a predetermined point (time point) along its route or line within a time period that is no more than x minutes earlier and no more than y minutes later than a published schedule time. (Values of 0 minutes for x and 5 minutes for y are the most common.)

open cut guideway—see *guideway, open cut*.

open-loop braking—see *braking, open-loop*.

open run—see *run, open*.

operating costs—the sum of all recurring costs (e.g., labor, fuel) that can be associated with the operation and maintenance of the system during the period under consideration. Operating costs usually exclude such fixed costs as depreciation on plant and equipment, interest paid for loans on capital equipment, and property taxes on capital items. See also *capital costs*.

operating employees (operating personnel)—1. Employees whose major function is operating the service, such as station employees, switchmen, bus drivers, train operators, conductors. 2. In rail operations, those employees that have direct and supervisory responsibility for the movement of transit units (cars or trains), embodying both on-board and wayside duties.

operating ratio—the ratio of operating expenses to operating revenue; the inverse of cost recovery ratio. It is used as a measure of financial efficiency. See also *fare recovery ratio*.

operating revenue, total—see *revenue, total operating*.

operating speed—see *speed, running*; and *speed, schedule*.

effective—see *speed, overall trip*.

operating time—see *time, operating*.

operating unit—see *basic operating unit*.

operation—see *operator* and *property*.

automatic train—see *automatic train operation*.

train—see *train operation*.

operational system—in system development, a system that is now available for use.

operations

joint—see *joint operations*.

mixed traffic—see *mixed traffic operations*.

operator—1. An employee of a transit system whose workday is spent in the operation of a transit unit (vehicle or train); examples include bus driver, gripman, motorman, rapid transit train motor operator. Such an employee may also be known as a *platform operator*. 2. The organization that runs a transportation system on a day-to-day basis and is also known as an *operation, property, or system*; see also *property*.

operator (*continued*)

car—see *operator, train*.

extra board (*extra, extra operator, reserved man*)—an operator who has no assigned run but is used to cover work (*extra work*) or runs (*extra runs*) deliberately left open by the scheduling department or runs that are open because of the absence of regularly assigned operators. A minimum guarantee, specified in the contract, is frequently paid if no work is available. See also *tripper*.

motor—see *operator, train*.

part-time—an operator expected to perform work on less than a full-time employee workweek basis. Wages, benefits, and duration of work are typically different from those of full-time operators.

platform—see *operator*.

rapid transit—see *operator, train*.

regular—an operator who has picked a regular run.

streetcar—see *operator, train*.

train (*motor operator, motorman*)—the operating employee who controls the movement of a rail transit unit (vehicle or train). Specific titles are also used, such as *car operator, rapid transit operator, streetcar operator*.

operator assignment sheet—see *sheet, assignment*.

operator pick—see *sign-up*.

operators' off-day board—1. A list of all routes that includes the number of crews and their picked days off. 2. A list of operators indicating their picked days off.

operator's subsidy—see *subsidy, provider-side*.

operator's travel time—see *time, journey*.

opportunities model, intervening—see *model, intervening opportunities*.

order

bad—see *bad order*.

slow—see *slow order*.

orders—authorization to move a train, as given by a train dispatcher either in writing or orally.

organizations—see also *U.S. Government* and *union, transit*.

American Association of State Highway and Transportation Officials (AASHTO)—membership includes state and territorial highway and transportation departments and agencies and the U.S. Department of Transportation. Its goal is to develop and improve methods of administration, design, construction, operation, and maintenance of a nationwide integrated transportation system. It studies transportation problems, advises Congress on legislation, and develops standards and policies.

American Bus Association (ABA)—membership is primarily privately owned bus operating firms in intercity, local, charter, and tour bus service; bus manufacturers; oil and gas refiners and distributors; travel and tourism organizations; and others concerned with the operation of bus service and promotion of motor coach tours. Its members

organizations (*continued*)

seek to improve the service that they provide and to develop increased bus use.

American Public Transit Association (APTA)—a non-profit international industry association made up of transit systems and other organizations and institutions connected to or concerned with the transit industry. It performs a variety of services for the industry, and its objectives include promotion of transit interests, information exchange, research, and policy development.

American Public Works Association (APWA)—members include those involved in the theory and practice of the design, construction, maintenance, administration, and operation of public works facilities and services. It conducts historical research on public works subjects, sponsors research and educational foundations, and operates a computerized local government information network. It includes a transportation council.

Association of American Railroads (AAR)—an industry association made up of individual railroads in the United States, Canada, and Mexico. It performs a variety of technical services for the railroads, and its purposes include the promotion of railroad interests and the standardization and coordination of operating and mechanical activities within the railroad industry.

citizen advisory committee (CAC)—an organized group of local people who supply their ideas and input to, for example, a particular transportation study or plan, a transit or paratransit operation, or a government agency.

council of governments (COG)—a voluntary consortium of local government representatives, from contiguous communities, meeting on a regular basis and formed to cooperate on common planning and to solve common development problems of their area.

Council of State Governments (CSG)—a joint agency of all state governments. It works to strengthen state government, promotes intergovernmental cooperation, disseminates information needed by states, and assists states in solving specific problems. It maintains the State Government Research Institute.

department of transportation (DOT)—a municipal, county, state, or federal agency responsible for transportation; see also *U.S. Government, Department of Transportation*.

Institute of Transportation Engineers (ITE)—a society of professionals in transportation and traffic engineering. It promotes education, research, the development of public awareness, and the exchange of professional information in these areas with the goal of contributing individually and collectively toward meeting human needs for mobility and safety.

International Taxicab Association (ITA)—an organization of fleet taxicab owners. It provides representation in Washington, D.C., disseminates information to its members and others concerned with taxicab operations, and conducts research and studies relevant to the problems of the taxi service industry.

organizations (*continued*)

International Union of Public Transport (UITP)—an association that pools information and experience of urban and interurban transportation undertakings for joint study and research and promotes technical and economic development.

metropolitan planning organization (MPO)—according to the United States Code, the organization designated by the governor and local elected officials as responsible, together with the state, for transportation planning in an urbanized area. It serves as the forum for cooperative decision making by principal elected officials of general local government.

National Association of Counties (NACo)—membership includes elected and appointed county governing officials and other county officials and their deputies at management or policy levels. This organization provides research and reference services for its members and represents them at the national level.

National Association of Regional Councils (NARC)—membership includes the regional councils of local governments and government agencies, and libraries, organizations, and others interested in regionalism as an approach to addressing issues that cross local government boundaries, such as transportation. The association provides legislative representation in Washington, D.C., and technical assistance through workshops and training programs.

National League of Cities (NLC)—a federation of state leagues and cities that develops and pursues a national municipal policy to meet the future needs of cities and to help them solve problems that they have in common. It represents municipalities before Congress and federal agencies; offers training, technical assistance, and information; and conducts a research program.

Presidents' Conference Committee (PCC, Electric Railway Presidents' Conference Committee)—a group of leading streetcar producers and operators who, between 1930 and 1935, sponsored the development of the PCC car. This car had performance characteristics superior to any previous model of streetcar and became the standard of U.S. streetcars for many years. See also *car, PCC*.

Public Utilities Commission (PUC, Public Service Commission, PSC)—a state agency whose responsibilities include regulation of for-hire (public and private) carriers of passengers and goods within a state. Other jurisdictions (e.g., a city) may also have a PUC or PSC that regulates for-hire carriers within that jurisdiction.

regional planning agency (RPA)—a nonprofit, quasi-public organization whose policy board is composed of member municipal government representatives. It makes recommendations related to land use, the environment, human resources, housing, and transportation for a specific region.

Transportation Research Board (TRB)—a unit of the National Research Council, operating under the corporate

organizations (*continued*)

authority of the private and nonprofit National Academy of Sciences. The purpose of TRB is to advance knowledge concerning the nature and performance of transportation systems by stimulating research and disseminating the information derived therefrom. Its affiliates and participants include transportation professionals in government, academia, and industry.

United Bus Owners of America (UBOA)—an organization of bus companies. It provides representation in Washington, D.C., for its members, disseminates information, provides insurance programs to members, and is especially concerned with safety and regulatory issues.

United States Conference of Mayors (USCM)—membership includes cities of more than 30,000 population, represented by their mayors. Its purpose is to promote improved municipal government by cooperation between cities and the federal government. It provides educational information, technical assistance, and legislative services to cities and conducts a research program.

origin—1. The point at which a trip begins. 2. In planning, the zone in which a trip begins.

origin-destination service—see *service, origin-to-destination*.

origin-destination study (O-D study)—a study of the origins and destinations of the trips of vehicles or travelers. It may also include trip purposes and frequencies.

outbound trip—see *trip, outbound*.

outline, market—see *market outline*.

outlying business district (OBD)—the portion of an urban area that is normally separated from the central business district and fringe area but that supports considerable business activity and has its own traffic circulation, superimposed on some through traffic.

output—something produced, for example, the result of an analytic process.

outside rail—see *rail, high*.

outside time—see *time, spread*.

overall travel time—see *time, linked trip*.

overall trip speed—see *speed, overall trip*.

overhead contact shoe (contact shoe, trolley shoe)—a metal bar for collecting current from an overhead conductor along which it slides. It is held in place by a pantograph or bow.

over-the-road coach—see *bus, intercity*.

overtime—time worked in excess of the basic workday or workweek, as defined by law, collective bargaining agreement, or company policy. It may also apply to any time worked on Saturdays, Sundays, and holidays at premium rates.

owl bonus—a premium paid employees for working owl runs (runs late at night, such as midnight to between 4 and 6 a.m.).

owl bus or run—see *run, owl*.

owl service—see *service, owl*.

P

P&R—park and ride.

PAS—public automobile service; see *transportation system, public automobile service*.

PCC—Presidents' Conference Committee; see *organizations, Presidents' Conference Committee*; and *car, PCC*.

PCC car—Presidents' Conference Committee car; see *car, PCC*.

PCE—passenger car equivalence.

PMSA—primary metropolitan statistical area; see *area, primary metropolitan statistical*.

PPBS—planning-programming-budgeting system.

PRT—personal rapid transit; see *transit system, personal rapid*.

PSC—Public Service Commission; see *organizations, Public Utilities Commission*.

PUC—Public Utilities Commission; see *organizations, Public Utilities Commission*.

paddle board (*paddle, run card, run guide, train card*)—the headway sheets (time schedule) made up for each run (operator's piece of work) that list all the pieces of work on that run (including any special notations) for the operator.

pad time—see *time, pad*.

paid area—see *area, paid*.

paid area transfer—see *transfer, paid area*.

paid break—see *time, intervening*.

paid miles—see *revenue vehicle miles*.

paid transfer—see *transfer, paid*.

pair, married—see *married pair*.

pallet-pod system—see *transportation system, pallet-pod*.

pallet system—see *transportation system, pallet*.

pantograph—a device for collecting current from an overhead conductor, characterized by a hinged vertical arm operated by springs or compressed air and a wide, horizontal contact surface that glides along the wire. Older versions usually consist of two parallel, hinged, double-diamond frames.

pantograph gates—gates located outside and at the end of transit cars so that when cars are coupled, their gates meet to prevent people from falling into the area between the cars.

parameter—1. A measurable fixed characteristic of a sample or population. 2. An independent variable used in the development of mathematical models.

paratransit—forms of transportation services that are more flexible and personalized than conventional fixed route, fixed schedule service but not including such exclusory services as charter bus trips. The vehicles are usually low- or medium-capacity highway vehicles, and the service offered is adjustable in various degrees to individual users' desires. Its categories are public, which is available to any user who pays a predetermined fare (e.g., taxi, jitney,

dial-a-ride), and semipublic, which is available only to people of a certain group, such as the elderly, employees of a company, or residents of a neighborhood (e.g., vanpools, subscription buses).

park and ride (*park 'n' ride, P&R*)—an access mode to transit in which patrons drive private automobiles or ride bicycles to a transit station, stop, or carpool/vanpool waiting area and park the vehicle in the area provided for that purpose (park-and-ride lot, park-and-pool lot, commuter parking lot, bicycle rack or locker). They then ride the transit system or take a car- or vanpool to their destinations.

parking

fringe (*peripheral parking*)—a parking facility located immediately outside the central business district, where personal vehicles may be parked and travelers may continue their trip to downtown via transit, carpool, or vanpool.

peripheral—see *parking, fringe*.

remote—1. A parking facility located beyond easy walking distance of an activity center (e.g., airport, fairgrounds, amusement park, industrial complex) that is connected to the activity center by a shuttle service (e.g., shuttle bus or van, elephant train). 2. A parking facility located a more significant distance from the central business district (e.g., in a suburban area or satellite community) than fringe parking, where personal vehicles may be parked and travelers continue their trip to downtown by transit, carpool, or vanpool.

parking facility—an area, which may be enclosed or open, attended or unattended, in which automobiles may be left, with or without payment of a fee, while the occupants of the automobiles are using other facilities or services.

parking supply—the total number of parking spaces within a given area or facility.

parking turnover—the ratio of the total number of parked vehicles accommodated during a given period in a specified area to the total number of parking spaces in that area.

parkway—an arterial highway for noncommercial traffic that has full or partial control of access. It is usually located within a park or a ribbon of parklike development. Certain types of traffic, such as truck or bus, may be prohibited from using parkways.

part-time employee—an employee expected to perform work on less than a 40-hr, full-time employee workweek basis. Such an employee's wages, benefits, and duration of work are typically different from those of full-time employees.

part-time operator—see *operator, part-time*.

part trip—see *trip, part*.

pass—1. A means of transit prepayment, usually a card, that a transit passenger displays to the operator, conductor, or fare inspector or processes through automatic fare-collection equipment instead of paying a cash fare. Passes are usually sold by the week or month. In some areas, to encourage tourism, they are also sold for shorter periods, sometimes with restricted hours for their use. 2. A means, usually a card, of granting free access to a transit system.

pass (*continued*)

This type of pass is issued to employees, visiting dignitaries, and so on. Employee passes usually carry some form of identification.

monthly—a pass valid for unlimited riding within certain designated zones for a 1-month period.

passenger—a person who rides a transportation vehicle, excluding the operator or other crew members of that transportation vehicle; see also *trip, passenger; trip, linked; and trip, unlinked*.

revenue—a passenger who pays (or has prepaid) a fare.

transfer—a passenger who changes from one route or line to another route or line.

passenger belt—see *moving walkway*.

passenger car equivalence (PCE)—the representation of larger vehicles, such as buses, as equal to a quantity of automobiles (passenger cars) for use in level of service and capacity analyses.

passenger controls—a system of railings, booths, turnstiles, and other fixtures for collecting fares and otherwise directing the movement of passengers. The controls may also be used to maintain the distinction between fare-paid and unpaid people.

passenger conveyer—see *moving walkway*.

passenger count—a count of the passengers on a vehicle or who use a particular facility.

passenger flow (passenger traffic)—the number of passengers who pass a given location in a specified direction during a given period.

passenger load—the number of passengers on a transit unit (vehicle or train) at a specified point.

passenger locomotive—see *locomotive, passenger*.

passenger mile (passenger kilometer)—the transportation of one passenger a distance of 1 mi (km).

passenger miles (passenger kilometers)—the total number of passengers carried by a transit system for a unit of time multiplied by the number of miles they travel. A comparison of passenger miles (kilometers) and seat miles (kilometers) provides a measure of transit system efficiency.

passenger miles per train mile (passenger kilometers per train kilometer)—the number of passenger miles (kilometers) accomplished by a given train mile (kilometer). The measure is the equivalent of load factor for buses, boats, or aircraft, but it also adjusts for distortions introduced as cars are added to trains. As an example, 100 people in one rail car of 100-passenger capacity is a load factor of 100 percent. If a car is added for 10 more passengers, the load factor drops to 55 percent — yet in many ways, productivity has gone up, not down.

passenger platform—see *platform*.

passenger riding count or check—see *check*.

passenger station—see *station*.

passenger traffic—see *passenger flow*.

passenger trip—see *trip, linked; trip, passenger; and trip, unlinked*.

passenger vehicle—see *vehicle, passenger*.

passenger volume (line volume)—the total number of passengers carried on a transit line during a given period.

passing track—see *siding*.

path—in planning, any series of links where each succeeding link has the ending node of a previous link as its beginning node.

minimum—see *minimum path*.

patron—see *rider*.

patronage—see *ridership*.

pavement markings—markings set into, applied on, or attached to the surface of the pavement for the purpose of regulating, warning, or guiding traffic.

pay

deadheading (deadhead pay, travel pay, travel time pay)—payment for being required to report for work at a point removed from the home terminal or to return without passengers after completing a run.

dismissal—see *pay, severance*.

premium—compensation at a rate higher than the regular rate as a result of overtime, shift differentials, or other contractual arrangement.

retroactive—current wage payments that are the result of wage increases that were determined to have become effective as of an earlier date.

separation—see *pay, severance*.

severance (dismissal pay or allowance, layoff allowance, separation pay, termination pay)—monetary allowance paid by an employer to displaced employees. Severance pay is generally awarded on permanent termination of employment (for reasons unrelated to performance on the job) with no chance of recall but is also often awarded in cases of indefinite recall with recall rights intact. The payment is often graduated by the length of service.

spread time premium (spread penalty, spread premium time)—1. Extra compensation paid for work performed in excess of a specified spread time, for example, 10 hours. 2. In some systems, extra compensation paid to certain employees whose duties require work during the morning and evening peak hours, with nonworking release time in between. This premium pay is to compensate for the inconvenience of working a split shift.

termination—see *pay, severance*.

travel or travel time—see *pay, deadheading*.

pay guarantee—a minimum level of pay for workers, usually per day or per week, that is stipulated by written contract.

payroll speed—see *speed, payroll*.

peak (peak period, rush hours)—1. The period during which the maximum amount of travel occurs. It may be specified as the morning (a.m.) or afternoon or evening (p.m.) peak. 2. The period when demand for transportation service is heaviest.

peak/base ratio (peak/off-peak ratio)—1. The ratio between the number of vehicles operating in passenger service

during the peak hours and that during the base period. 2. The ratio between the number of passengers carried during the peak hours and that during the base period.

peak fare—see *fare, time-of-day*.

peak-hour conversion factor—see *peak-hour factor*.

peak-hour factor (*peak-hour conversion factor*)—the ratio of the volume during the peak hour to the maximum rate of flow during a selected period within the peak hour.

peak-hour pricing—see *pricing, peak-hour*.

peak period—see *peak*.

peak service—see *service, peak*.

pedestrian—a person traveling on foot.

pedestrian assist—see *transportation system, pedestrian assist*.

pedestrian conveyor—see *moving walkway*.

pedestrian island—see *loading island*.

pedestrian refuge—a space designed for the use and protection of pedestrians, including both the safety zone and the area at the approach that is usually outlined by protective deflecting or warning devices; see also *loading island*.

pedestrian signal-actuating device—a device to actuate traffic signals that is designed to be used by pedestrians.

penalty, spread—see *pay, spread time premium*.

penalty rate—1. An extra rate of pay for particularly hazardous or onerous work. 2. Sometimes applied to any premium or overtime rate of pay.

penalty time—see *time, penalty*.

people mover—an automated transportation system (e.g., continuous belt system or automated guideway transit) that provides short-haul collection and distribution service, usually in a major activity center.

downtown (DPM)—a people mover that primarily serves internal movements in a central business district.

performance, on-time—see *on-time performance*.

performance audit—in transit operations, an evaluation of a transit system's efficiency and effectiveness; a management review focusing on system's goals, objectives, and performance. A performance audit is also used to determine whether the transit agency is complying with local, state, and federal regulations on such matters as highway safety, pollution control, handicapped accessibility, and achievement of revenue-to-cost ratios.

performance indicator (*measure of effectiveness*)—a quantitative measure of how well an activity, task, or function is being performed. In transportation systems, it is usually computed by relating a measure of service output or use to a measure of service input or cost.

period

base or off-peak—see *base period*.

peak—see *peak*.

peripheral parking—see *parking, fringe*.

permissive block—see *block, absolute permissive*.

person trip—see *trip, person*.

personal rapid transit—see *transit system, personal rapid*.

Personal Transportation Study, Nationwide—see *Nationwide Personal Transportation Study*.

personnel, operating—see *operating employees*.

pick—see *sign-up*.

pick-out or picking sheet—see *sheet, pick-out*.

piece of work (*piece*)—in transit operations, a unit of work of any size from part of a trip to a full day's run of round trips.

pilot—1. In rail operations, a qualified person assigned to assist train crews who are operating over unfamiliar track-
age or operating unfamiliar equipment. 2. On rail vehicles, a wheel guard that protects the front truck of a rail vehicle from foreign objects on the track; also known as a *cowcatcher*.

pinched loop—see *loop, pinched*.

pitch—a rising and falling motion about the transverse axis.

plan

action—see *action plan*.

guaranteed annual wage—see *guaranteed annual wage plan*.

marketing—see *marketing planning*.

sketch—see *sketch planning*.

system—see *system planning*.

planning process—in transportation, the process required by federal transit and highway legislation through which communities develop proposals for transportation projects designed to serve the needs of an area; see also *urban transportation planning process*.

four-step—see *urban transportation modeling system*.

unified—see *unified planning work program*.

urban transportation—see *urban transportation planning process*.

Urban Transportation—see *Urban Transportation Planning System*.

planning-programming-budgeting system (PPBS, program budgeting)—a planning and management process in which resources of an organization are allocated to identified individual programs, in contrast to the administrative budget grouping of resources by type of disbursement.

plate, inspection—see *inspection plate*.

platform (*passenger platform*)—that portion of a transit facility directly adjacent to the tracks or roadway at which transit units (vehicles or trains) stop to load and unload passengers. Within stations, it is often called a *station platform*.

center—a passenger platform located between two tracks or guideways so that it can serve them both.

high—a platform at or near the floor elevation of the transit unit (vehicle or train), eliminating the need for steps on the transit unit.

low—a platform at or near the top of the running surface of the transit unit (vehicle or train), requiring the passenger to use steps to board and alight.

side—a passenger platform located to the outside of the tracks or guideways, as distinguished from a center platform located between the tracks or guideways.

platform operator—see *operator*.

platform time—see *time, platform*.

platoon, bus—see *bus platoon*.

p.m. peak—see *peak*.

pneumatic brake—see *brake, electropneumatic*.

point

dispatch—see *dispatch point*.

indication—see *indication point*.

junction—see *junction point*.

maximum load—see *maximum load point*.

merge—see *merge point*.

relief—see *relief point*.

time—see *time point*.

turnover—see *turnover point*.

point accessibility—see *accessibility, point*.

point check—see *check*.

point control system, moving—see *control system, moving slot*.

point deviation service—see *service, point deviation*.

point-follower control system—see *control system, moving slot*.

point of convergence—the location at which two transit routes meet and then continue on the same alignment.

point of divergence—the point at which two transit routes separate after operating over the same alignment.

point of extension—the point at which one transit route is lengthened from an existing route.

point of intersection—the point at which one transit route crosses or abuts another route.

point-to-point deviation—a transit routing pattern in which the vehicle passes through prespecified points in accordance with a prearranged schedule but is not given a specific route to follow between these points. It may provide door-to-door or curb-to-curb service. See also *service, point deviation*.

pole, trolley—see *trolley pole*.

policy—in transportation, a definite course, selected from among alternatives, to guide and determine decisions on transportation matters. The policy prescribes the limits within which effort toward goal achievement must stay.

policy headway—see *headway, policy*.

pollution, air—see *air pollution*.

pool—see *buspool, carpool, and vanpool*.

population (*universe*)—in planning, each and every member of some group of interest for the purposes of statistical description or inference.

postcard survey—see *survey, postcard*.

posting, job—see *job posting*.

potential, market—see *market potential*.

power, dual—see *propulsion system, dual-power*.

powered car—see *car, rail motor*.

power rail—see *rail, third*.

powers agreement, joint—see *joint powers agreement*.

power system—the electrical devices and equipment that convert, transmit, and use power to operate a vehicle.

preemption, signal—see *signal preemption*.

preferential bus lane—see *lane, bus*.

preferential treatment—in transportation, giving special privileges to a specific mode of transportation; bus lanes and signal preemption are examples.

preferred alternative—in an alternatives analysis, the alternative favored for implementation over the others studied.

preliminary engineering (*preliminary design*)—that portion of the development of a project during which the basic planning objectives are translated into specific, well-defined criteria that can permit the final design process to begin.

pre-metro system—see *transit system, pre-metro*.

premium, shift—see *shift differential*.

premium pay—see *pay, premium*.

spread time—see *pay, spread time premium*.

premium time—see *time, pad*.

preparation and storage time—see *time, preparation and storage*.

Presidents' Conference Committee—see *organizations, Presidents' Conference Committee*; and *car, PCC*.

Presidents' Conference Committee car—see *car, PCC*.

pretest—in planning, a test of the procedures to be used in conducting a travel or other survey.

preventive maintenance—see definition of *maintenance*.

price elasticity—see *elasticity, price*.

price index, consumer—see *consumer price index*.

pricing—a strategy for charging users. It may be used to ration demand (change behavior), cover costs, or achieve other policy objectives.

peak-hour—charging higher prices for peak-period service than for off-peak service.

time-of-day—varying the price of service during the day.

pricing objectives—the goals that a company or public agency seeks to reach through implementation of its pricing strategy.

primary metropolitan statistical area—see *area, primary metropolitan statistical*.

priority lane—see *lane, priority*.

bus—see *lane, bus*.

priority system, bus—see *bus priority system*.

private siding—see *siding, private*.

private transportation—1. Any transport service that is restricted to certain people and is therefore not open to the public at large. 2. Owned or operated by an individual or group, not by a governmental entity, for his or its own purposes or benefit.

privatization—the contracting of public services or selling of public assets to private industry.

probabilistic model—see *model, probabilistic*.

probability—1. The relative frequency with which an event occurs or is likely to occur. 2. In statistics, the relative possibility that an event will occur, as expressed by the ratio of the number of actual occurrences to the total number of possible occurrences.

probability sampling—see *sampling, probability*.

process

Delphi—see *Delphi process*.

deterministic—see *deterministic process*.

four-step planning—see *urban transportation modeling system*.

Intergovernmental Review—see *Intergovernmental Review Process*.

planning—see *planning process*.

stochastic—see *stochastic process*.

3C—see *3C process*.

urban transportation planning—see *urban transportation planning process*.

procurement

life cycle—see *life cycle procurement*.

low bid—see *low bid procurement*.

product deflator, gross national—see *gross national product deflator*.

productions, trip—see *trip productions*.

productivity—the ratio of units of transportation output to units of input (consumed resource); for example, vehicle miles (vehicle kilometers) per operator hour, or passenger miles (passenger kilometers) per unit cost of operation.

profile, market—see *market profile*.

program

National Cooperative Research—see *National Cooperative Highway Research Program* and *National Cooperative Transit Research and Development Program*.

Research, Development, and Demonstration—see *Research, Development, and Demonstration Program*.

Service and Methods Demonstration—see *Service and Methods Demonstration Program*.

Transit Development—see *Transit Development Program*.

transportation improvement—see *transportation improvement program*.

unified planning work—see *unified planning work program*.

program budgeting—see *planning-programming-budgeting system*.

programmed braking—see *braking, programmed*.

progression, automatic—see *automatic progression*.

projects, Interstate substitution transfer—see *Interstate substitution transfer projects*.

property (operation, operator, system)—in the transit industry, a public transit agency or a private transit company with responsibility for transportation services such as bus, ferry, rail; see also *transit district*.

proportional sampling—see *sampling, stratified*.

proportional trip assignment—see *trip assignment, proportional*.

proposals, request for—see *request for proposals*.

propulsion system—the motors, driving mechanism, controls, and other devices that propel a vehicle.

dual-power—a propulsion system that is capable of op-

propulsion system (continued)

eration from two different types of power sources, for example, an internal combustion engine and electricity.

prospectus—1. In transportation, a document that describes proposed activities in transportation planning over a specified period of time, predicts future conditions in the region, assigns responsibility for planning and implementing transportation services, and discusses transportation alternatives for the future. 2. A document presenting the qualifications and experience of a consultant.

protection, train—see *automatic train protection*.

prototype system—in system development, a system that has been built to demonstrate its capability to operate in the manner intended; see also *vehicle, prototype*.

prototype vehicle—see *vehicle, prototype*.

provider-side subsidy—see *subsidy, provider-side*.

public automobile service system—see *transportation system, public automobile service*.

publicly owned transit system—see *transit system, publicly owned*.

Public Service or Utilities Commission—see *organizations, Public Utilities Commission*.

public service vehicle—see *vehicle, public service*.

public transit (mass transit)—passenger transportation service, usually local in scope, that is available to any person who pays a prescribed fare. It operates on established schedules along designated routes or lines with specific stops and is designed to move relatively large numbers of people at one time. Examples include bus, light rail, rapid transit.

public transportation—transportation service to the public on a regular basis using vehicles that transport more than one person for compensation, usually but not exclusively over a set route or routes from one fixed point to another. Routes and schedules of this service may be predetermined by the operator or may be determined through a cooperative arrangement. Subcategories include public transit service and paratransit services that are available to the general public.

urban—see *urban public transportation*.

public transportation disability—see *handicapped*.

public way—any public street, road, boulevard, alley, lane, or highway, including those portions of any public place that have been designated for use by pedestrians, bicycles, and motor vehicles.

pull-in—1. A deadhead trip from the point at which the transit unit (vehicle or train) ends an in-service trip to the garage or yard. 2. A transit unit (vehicle or train) that is returning to the garage or yard; see also *time, pull-in*.

pull-in time—see *time, pull-in*; and *time, turn-in*.

pull-out—1. A deadhead trip from the garage or yard to the point at which the transit unit (vehicle or train) begins an in-service trip. 2. A transit unit (vehicle or train) that is leaving a garage or yard; see also *time, pull-out*.

pull-out time—see *time, pull-out*; and *time, report*.

purchased transportation (carriers under contract)—transportation service purchased by a public agency from a

public or private transportation provider on the basis of a written contract.

purpose, trip—see *trip purpose*.

push-pull train—see *train, push-pull*.

push-through—a bus-operating technique used in busy peak-hour street operations when heavy passenger loads can combine with general road traffic delays to create bunching. A push-through is an unscheduled bus that is held at a key point, to be inserted by an inspector or street supervisor into a route when a serious gap occurs. It is used to prevent worsening of service.

Q

qualitative interview—an open-ended, detailed, or in-depth survey technique, the findings of which are not generally projectable and cannot be summed up by tabulation; see also *survey, quantitative*.

quality

ambient air—see *ambient air quality*.

ride—see *ride quality*.

service—see definition of *level of service*.

quality assurance—the systematic use of performance requirements, design criteria, specifications, production control procedures and acceptance plans for materials, processes, or products to ensure prescribed properties or characteristics.

quality control—the system of collection, analysis, and interpretation of measurements and other data concerning prescribed characteristics of a material, process, or product, for determining the degree of conformance with specified requirements.

quantitative survey—see *survey, quantitative*.

quasi-synchronous network control system—see *control system, quasi-synchronous network*.

queue—1. A line of waiting vehicles, for example, traffic at a signal, or buses at a park-and-ride facility. 2. A line of waiting people.

queue jumper—1. A short section of exclusive or preferential lane that enables specified vehicles to bypass an automobile queue or a congested section of traffic. A queue jumper is often used at signal-controlled freeway on-ramps in congested urban areas to allow high-occupancy vehicles preference. It is also known as a *bypass lane* or *queue bypass*. 2. A person who violates passenger controls.

quota sampling—see *sampling, quota*.

R

RD&D—Research, Development, and Demonstrations Program.

RDC—rail diesel car; see *car, rail diesel*.

RGR—regional rail; see *service, regional rail*.

ROW—right-of-way.

RPA—regional planning agency; see *organizations, regional planning agency*.

RRIS—Railroad Research Information Service.

RUCUS—Run Cutting and Vehicle Scheduling.

rack railway—see *cog railway*.

radial highway—see *highway, radial*.

radial network—see *network, radial*.

radio-controlled engine—see *engine, radio-controlled*.

radius of curvature—a rating of the severity of a curve by comparing it to an arc of a circle of stated radius.

rail—a rolled steel shape laid in two parallel lines to form a track for carrying vehicles with flanged steel wheels.

contact—see *rail, third*.

continuous welded (CWR)—a number of standard length rails welded together into a single length of 400 or more ft (122 or more m). It provides a smoother running surface and ride than jointed rail.

corrugated—a rough condition of alternate ridges and grooves that develops on rail tread in service.

fourth—an electrical conductor that provides ground return or negative return for systems in which the running rails are not used for that purpose.

guard—see *guardrail*.

high (outside rail)—the outer or superelevated rail of a curved track.

inside—see *rail, low*.

low (inside rail)—the inner rail of a curve that has at-grade alignment, whereas the opposite or outer rail is elevated.

outside—see *rail, high*.

power—see *rail, third*.

restraining—a rail placed parallel to the inside running rail on a curve to restrain the wheel flange and reduce wear on the outside running rail.

running—a rail that supports and guides the flanged wheels of the rail vehicle.

standard—a 39-ft (11.89-m) section of rail.

stock—a running rail against which the switch rail operates.

third (contact rail, power rail)—an electric conductor, located alongside the running rail, from which power is collected by means of a sliding shoe attached to the truck of electric rail cars or locomotives.

welded—two or more rails welded together at their ends to form a length less than 400 ft (122 m); see also *rail, continuous welded*.

rail anchor (*anticreeper*)—a track device for ballasted track designed to prevent longitudinal rail movement (creep) caused by factors such as traffic or temperature variations.

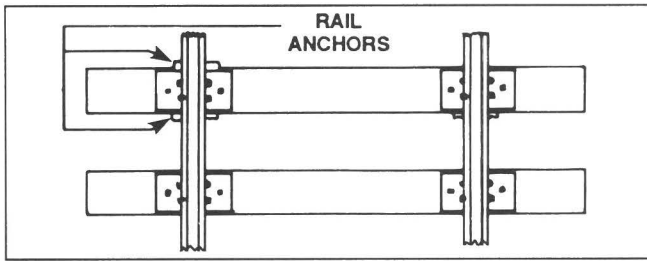

railbus—a relatively light, diesel-powered, two-axle rail vehicle with a body resembling that of a bus.

rail car

electric—see *car, electric rail*.

urban—see *car, urban rail*.

rail creep—longitudinal rail movement, caused by, for example, traffic or temperature variations.

rail diesel car—see *car, rail diesel*.

rail joint—a fastening designed to unite abutting ends of contiguous rails.

bonded—a rail joint that uses high-strength adhesives in addition to bolts to hold rails together. The bonded joint may be insulated or noninsulated. On electrified track, it conducts electrical power back to the powerhouse.

compromise—a rail joint between rails of different height and section, or rails of the same section but of different joint drillings.

insulated—a rail joint designed to arrest the flow of electric current from rail to rail by means of insulation placed so as to separate the rail ends and other metal parts connecting them.

rail motor car—see *car, rail motor*.

rail rapid transit—see *transit system, rail rapid*.

rail rapid transit car—see *car, rail rapid transit*.

railroad, commuter—see *transit system, commuter rail*.

railroad grade crossing—see *crossing, railroad grade*.

Railroad Research Information Service (RRIS)—a computer-based information storage and retrieval system developed by the Transportation Research Board with financial support from the Federal Railroad Administration. It consists of summaries of research projects in progress and abstracts of published works.

railroad tie—see *cross-tie*.

rail transit system—see *transit system, rail*.

rail transport, conventional—see *conventional rail transport*.

rail tread—the top surface of the rail that contacts the wheels of the rail vehicle.

rail vehicle, articulated—see *articulated rail vehicle*.

railway

cog—see *cog railway*.

electric incline—see *electric incline railway*.

railway (*continued*)

funicular—see *funicular railway*.

inclined plane—see *inclined plane railway*.

metropolitan—see *transit system, rail rapid*.

rack—see *cog railway*.

street—see *transit system, streetcar*.

railway crossing—see *crossing, track*.

railway electrification—see *electrification*.

ramp—1. In highway systems generally, an inclined section of roadway over which traffic passes for the primary purpose of ascending or descending to make connections with other roadways. It can also be an interconnecting roadway of an interchange, or any connection between highway facilities of different elevations that vehicles may use to enter or leave a designated highway. 2. For divided highways specifically, a facility that provides access to the through lanes of freeways and expressways or connects two freeways. 3. In traffic assignment, a link that connects a freeway node and an arterial node.

moving—an inclined moving walkway.

ramp meter bypass lane—see *lane, ramp meter bypass*.

ramp metering—1. The process of facilitating traffic flow on freeways by regulating the amount of traffic entering the freeway through the use of control devices on entrance ramps. 2. The procedure of equipping a freeway approach ramp with a metering device and traffic signal that allow the vehicles to enter the freeway at a predetermined rate.

random sampling—see *sampling, random*.

rapid, the—see *transit system, rail rapid*.

rapid rail transit—see *transit system, rail rapid*.

rapid transit car—see *car, rail rapid transit*.

rapid transit operator—see *operator, rapid transit*.

rapid transit system—see specific entries under *transit systems*: bus rapid, group rapid, light rail rapid, personal rapid, rail rapid.

rate

base—see *base rate*.

discount—see *discount rate*.

penalty—see *penalty rate*.

rate of flow—see *flow rate*.

ratio

benefit-cost—see *benefit-cost ratio*.

cost recovery—see *cost recovery ratio*.

fare or farebox recovery—see *fare recovery ratio*.

operating—see *operating ratio*.

peak/base or peak/off-peak—see *peak/base ratio*.

travel time—see *travel time ratio*.

reader, farecard—see *farecard reader*.

recall—the process of bringing laid-off employees back to work, usually based on the same principles that governed the order of layoff but in inverse order (e.g., the last worker to be laid off is first to be recalled). Usually, the order is determined by seniority, whereby the worker with the most seniority is given the first opportunity to return to work.

recipient, designated—see *designated recipient*.

recovery ratio—see *cost recovery ratio* and *fare recovery ratio*.

recovery time—see *time, layover*.

rectifier electric motor car—see *car, rectifier electric motor*.

reduced fare—see *fare, reduced*.

redundancy—the existence in a system of more than one means of accomplishing a given function.

refuge, pedestrian—see *pedestrian refuge*.

regenerative brake—see *brake, regenerative*.

region accessibility—see *accessibility, region*.

regional growth model—see *model, regional growth*.

regional planning agency—see *organizations, regional planning agency*.

regional rail service—see *service, regional rail*.

regional transit service—see *service, regional transit*.

Register, Federal—see *Federal Register*.

register or registering farebox—see *farebox, registering*.

regression analysis—a statistical technique for estimating best-fit mathematical relationships between a dependent variable and one or more independent variables.

regular fare—see *fare, base*.

regular operator—see *operator, regular*.

regular run—see *run, regular*.

Regulations, Code of Federal—see *Code of Federal Regulations*.

relationship, speed-flow—see *speed-flow relationship*.

relay, track—see *track relay*.

relay time—see *time, layover*.

reliability—the probability that a specified function will be performed without failure and within the design parameters for the period of time intended, under actual operating conditions.

relief person (relief man)—an operator who replaces another operator at the completion of the relieved operator's assigned run or portion of run.

relief point—a designated time point at which operators may take a lunch period or rest break, or a point at which an operator is relieved by another operator, that is, where one run is completed and another starts.

relief run—see *run, relief*.

relief time—see *time, relief*.

remote parking—see *parking, remote*.

report time—see *time, report*.

request for proposals—a document announcing a proposed project, describing the scope of the work and the criteria to be used by potential consultants in developing proposals for the work and outlining the evaluation process.

reroute—to divert to a route other than the scheduled route, usually with preplanning and for a longer period than that for a detour.

research

marketing—see *marketing research*.

motivational—see *motivational research*.

Research, Development, and Demonstration Program (RD&D)—an Urban Mass Transportation Administration

program to stimulate technological, institutional, and operational improvements in public transportation.

Research Information Service—see *Highway Research Information Service, Railroad Research Information Service, Transportation Research Information Services, and Urban Mass Transportation Research Information Service*.

Research Program—see *National Cooperative Highway Research Program and National Cooperative Transit Research and Development Program*.

reserved man—see *operator, extra board*.

reserved transit lane—see *lane, exclusive transit*.

resources sites, symbolic—see *symbolic resources sites*.

response time—see *time, response*.

responsible agency—a public agency that proposes carrying out a project but is not necessarily the lead agency for the project.

restoration of service—the resumption of service according to schedule after it has been interrupted or operating off schedule.

restraining rail—see *rail, restraining*.

retirement—in labor, withdrawal from working life or from a particular employment, usually because of age or disability and usually with a pension.

retroactive pay—see *pay, retroactive*.

revenue

charter service—revenue earned by operating vehicles under charter contracts.

farebox—the passenger payments for rides, including cash, farecards, tickets, tokens, pass receipts, and transfer and zone charges but excluding charter revenue.

nontransportation—revenue earned by activities not associated with the provision of the system's transit service, for example, sales of maintenance services, rental of vehicles and buildings, nontransit parking lots, sale of advertising space, and investment income.

total operating—the sum of regular passenger revenue, charter revenue, and other miscellaneous revenues, such as those from advertising or concessions.

revenue miles (revenue kilometers)—miles (kilometers) operated by vehicles available for passenger service.

revenue passenger—see *passenger, revenue*.

revenue seat mile (revenue seat kilometer)—the movement of one transit passenger seat over 1 mi (km). In other words, the total number of revenue seat miles (kilometers) for a vehicle is obtained by multiplying the number of revenue seats in the vehicle by the number of revenue miles (kilometers) traveled.

revenue service—see *service, revenue*.

revenue track miles or kilometers—see *track miles, revenue*.

revenue vehicle—see *vehicle, revenue*.

revenue vehicle miles (revenue vehicle kilometers, paid miles or kilometers)—the distance in miles (kilometers) that a revenue vehicle is operated while it is available for passenger service.

reverse commute—see *commute, reverse*.

reverse move—the forward movement of a train going against the normal direction of traffic.

reversible bus lane—see *lane, reversible bus*.

reversible lane—see *lane, reversible*.

Review Process, Intergovernmental—see *Intergovernmental Review Process*.

ride

check—see *check ride*.

one-zone—see *one-zone ride*.

shared—see *shared ride*.

ride quality—a measure of the comfort level experienced by a passenger in a moving vehicle, including the vibration intensity and frequency, accelerations (longitudinal, transverse, and vertical), jerk, pitch, yaw, and roll.

rider—1. A passenger on any revenue service vehicle; also known as a *patron*. 2. In government reporting, someone making an unlinked trip.

captive—a person limited by circumstances to use one mode of transportation; see also *transit dependent* and *transportation disadvantaged*.

captive transit—a person who does not have a private vehicle available or cannot drive (for any reason) and who must use transit to make the desired trip; see also *transit dependent* and *transportation disadvantaged*.

choice—a person who has at least two modes of travel available and selects one to use.

riders, group—riders who have a common origin and destination or some demographic variable in common and travel together in the same vehicle.

ridership (patronage)—the number of people making one-way trips on a public transportation system in a given time period.

ridesharing—a form of transportation, other than public transit, in which more than one person shares in the use of the vehicle, such as a bus, van, or automobile, to make a trip.

riding check or count, passenger—see *check*.

riding frequency coefficient (riding habit coefficient)—the number of passenger trips during a designated time period divided by the resident population of the area served, that is, transit trips per capita per year.

right-of-way (ROW)—1. A general term denoting land, property, or interest therein, usually in a strip, acquired for or devoted to transportation purposes. For transit, rights-of-way may be categorized by degree of their separation: A—fully controlled without grade crossings, also known as *grade separated, exclusive, or private*; B—longitudinally physically separated from other traffic (by curbs, barriers, grade separation, etc.) but with grade crossings; C—surface streets with mixed traffic, although transit may have preferential treatment. 2. The precedence accorded to one vehicle or person over another. 3. The legal right of passage over another person's land.

exclusive—a lane or other facility that is fully grade separated or access controlled and is used only by a specified mode or specified vehicles at all times.

right-of-way (continued)

exclusive transit—a right-of-way that is fully grade separated or access controlled and is used exclusively by transit; transit ROW category A.

right-of-way miles (right-of-way kilometers, first-track miles or kilometers)—the length of right-of-way occupied by one or more lanes or tracks; see also *route miles*.

rights, air—see *air rights*.

rim—on a rail car wheel, that portion around the outer circumference that forms the edge of the tread. The thickness of the rim is a measure of the amount of wear remaining in the wheel, and when this dimension reaches a given limit, the wheel must be scrapped.

risk management—an element of the systems safety management function that evaluates the effects of potential hazards on safety by considering acceptance, control, or elimination of such hazards with respect to expenditure of resources.

road—see *highway, street, or road*.

access—a road that gives direct access to the land and premises on one or both sides.

bypass—a road that takes through traffic around a congested area and thereby facilitates through movement and relieves local congestion.

collector—see *street, collector-distributor*.

frontage—a local street or road auxiliary to and located on the side of a freeway, expressway, or arterial highway for service to abutting property and adjacent areas and for control of access to the freeway, expressway, or arterial highway.

roadbed—1. In railroad construction, the foundation on which the ballast and track rest. 2. In highway construction, the graded portion of a highway within top and side slopes, prepared as a foundation for the pavement structure and shoulder.

road call—a mechanical failure of a bus in revenue service that necessitates removing the bus from service until repairs are made.

road miles (road kilometers)—linear miles (kilometers) of highway as measured along the centerline of the right-of-way.

roadside survey—see *survey, roadside*.

road supervisor—see *inspector*.

roadway—that portion of a highway built, designed, or ordinarily used for vehicular travel, except the berm or shoulder. If a highway includes two or more separate roadways, the term means any such roadway separately but not all such roadways collectively.

roll—motion about the longitudinal axis of a vehicle.

rolling stock—see *fleet*.

rolling stock capacity—see *capacity, fleet*.

roster—see *sheet, assignment*.

rotating shift—see *shift, rotating*.

rotor—the rotating member of motors, generators, or motor-type relays.

roundhouse—a building, circular in design, used to house locomotives while they are being serviced or repaired; see also *barn*.

round trip—see *trip, round*.

route—1. The geographical path followed by a vehicle or traveler from start to finish of a given trip. 2. A designated, specified path to which a transit unit (vehicle or train) is assigned. Several routes may traverse a single portion of road or line. 3. In traffic assignments, a continuous group of links that connects two centroids, normally the path that requires the minimum time to traverse. 4. In rail operations, a determined succession of contiguous blocks between two controlled interlocked signals.

bicycle—see *bicycle route*.

route deviation service—see *service, route deviation*.

route miles (route kilometers)—various definitions exist for this statistic: 1. One-way duplicating is total mileage (kilometers) of routes, where the roadway or guideway segments of each individual route are summed up in one direction. For example, a 1-mi (km) segment over which buses operate in both directions would be reported as 2 mi (km); also known as *directional route miles (kilometers)* or *miles (kilometers) of roadway or route*. 2. One-way non-duplicating is total mileage (kilometers) of routes, where a particular roadway or guideway segment is only counted once regardless of number of routes or direction of travel on that segment; also known as *line miles (kilometers)* or *miles (kilometers) of directional roadway*. 3. Two-way mileage (kilometers) is total mileage (kilometers) of each route covered from start to finish. No attention is given to direction of routes or number of routes using any particular segment of roadway or guideway.

route structure—1. A network of transit routes. 2. The pattern of transit routes, for example, grid, radial.

route supervisor—see *inspector*.

routing

dynamic—see *dynamic routing*.

through—see *through routing*.

routing and control algorithm—a numerical technique for assigning trips (usually vehicle trips) to routes and controlling flows of traffic in simulation of transportation networks.

rule—in rail operations, a law or order authoritatively governing conduct or action.

run—1. The movement of a transit unit (vehicle or train) in one direction from the beginning of a route to the end of it; also known as a *trip*. 2. An operator's assignment of trips for a day of operation; also known as a *work run*.

base—a regular run that has no unpaid breaks and is normally 8 hr in duration.

bus—the daily assignment of a bus, numbered and listed in a master schedule. Each vehicle displays its bus run number.

extra—see *run, open*.

leader—a run that operates ahead of another run on the same route or line.

one-piece—an operator's daily work schedule for which the operator stays on the same transit unit (vehicle or train) without relief. It usually is about 8 hr long.

run (continued)

open (extra run)—a run that is put into effect after other runs have been assigned and that normally will be assigned from the extra board until the next picking of runs or will be put up for bid by seniority.

owl (owl bus)—a run that operates during the late night through early morning hours; most commonly, midnight to 4 or 6 a.m.

regular—a scheduled combination of transit trips, the total time of which guarantees, equals, or exceeds payment for the number of hours specified as an operator's day's work.

relief—a week's work composed of a combination of other operators' scheduled days off from regular runs.

split (swing run)—two operating assignments separated by a period of time during which the operating employee is unassigned and not paid.

straight—a run that has no unpaid breaks in it.

swing—see *run, split*.

work—the daily assignment of an operator. It may include operation over more than one route or line.

run card—see *paddle board*.

run cutting—the process of organizing all scheduled trips operated by the transit system into runs for the assignment of operating personnel and vehicles.

Run Cutting and Vehicle Scheduling (RUCUS)—a computerized transit scheduling program.

run guide—see *paddle board*.

running gear—the vehicle parts whose functions are related to the movement of the vehicle, including the wheels, axles, bearings, and suspension system.

running hot (running sharp)—running ahead of schedule.

running rail—see *rail, running*.

running speed—see *speed, running*.

running time—see *time, running*.

run pick or picking—see *sign-up*.

runs, bidding—see *sign-up*.

rural area—see *area, rural*.

rush hour(s)—see *peak*.

S

SLIM—single-sided linear induction motor; see *motor, single-sided linear induction*.

SLT—shuttle-loop transit; see *transit system, shuttle-loop*.

SMD Program—Service and Methods Demonstration Program.

SMSA—standard metropolitan statistical area; see *area, standard metropolitan statistical*.

SSLIM—single-sided linear induction motor; see *motor, single-sided linear induction*.

SU—single unit; see *car, single-unit*.

saddle monorail—see *transit system, monorail*.

sample—a part of a statistical population (universe) that is studied to gain information about the whole.

sampling—the process or technique of selecting a suitable sample.

area—a method of sampling that divides a geographical region into smaller areas and uses random selection to determine specific areas or respondents to be interviewed.

probability—a method of sampling in which each unit of the universe has a known chance of selection.

proportional—see *sampling, stratified*.

quota—a method of sampling designed to obtain a specific number of respondents with known characteristics.

random—a form of probability sampling in which each unit of the universe has an equal chance of selection.

stratified (proportional sampling)—a method of sampling that sets a quota for certain classifications of the population being sampled on the basis of the proportion of each classification in the total population (universe) or of previous information about the relative distributions in these classifications.

scatter service—see *service, one-to-many*.

schedule—1. A listing or diagrammatic presentation in time sequence of every trip and every time point of each trip, from start to finish of service, on a transit line or route. 2. In transit or railroad operations, a published table of departure or arrival times (or both) for arranged service over a transit line or route or a specific section of railroad; see also *timetable*.

track—a document issued on a regular basis that describes the departments and personnel that are scheduled to occupy any portion of track during the following week. Use of a track schedule is usually associated with heavy track maintenance work.

schedule check—see *check*.

schedule checker—see *checker*.

schedule speed—see *speed, schedule*.

scheduling—in transit operations, the process of preparing the operating plan (schedule) for a transit line or network on the basis of passenger demand, policy for level of service, and operating elements (travel times, etc.).

school bus—see *bus, school*.

school bus service—see *service, school bus*.

scoping—in planning, the setting of parameters.

screen line—an imaginary line, usually following such physical barriers as rivers or railroad tracks, that splits a study area into parts and along which traffic counts and interviews may be conducted and compared.

seating or seated capacity—see *capacity, seating*.

seat mile, revenue—see *revenue seat mile*.

section—for sections of legislation, see definition of *legislation*.

block—see *block*.

section (continued)

extra—see *extra section*.

maximum load—see *maximum load section*.

Section 13(c) agreement—a written agreement between a recipient of federal assistance under the Urban Mass Transportation Act of 1964, as amended, and unions representing the workers affected by the assistance that is designed to comply with the requirements of Section 13(c) of the Act. If affected workers are not represented by unions, then the recipient alone signs an agreement acceptable to the Secretary of Labor.

segment, market—see *market segment*.

segmentation, market—see *market segmentation*.

selected link analysis—in planning, an analysis of origins and destinations of trips assigned to a specified link or links in a network.

self-certification—a procedure by which a local agency assures the federal agency that all the federal rules and regulations have been followed and adhered to; see also *certification*.

self-propelled locomotive—see *locomotive, self-propelled*.

self-propelled or self-powered car—see *car, rail motor*.

self-service, barrier-free fare collection system—see *fare collection system, self-service, barrier-free*.

semantic differential technique—in attitudinal research, a method of rating the emotional connotations of words and concepts by the use of adjectives paired with their opposites.

semi-metro system—see *transit system, semi-metro*.

seniority—the status of an employee, as measured by length of employment in relation to other employees, for such purposes as determining order of promotion, layoff, and so on. Seniority is normally calculated from the date of hire or the first day worked in a classification; therefore those employed longest have the most seniority.

sensor, induction loop—see *induction loop sensor*.

separation, grade—see *grade separation*.

separation pay—see *pay, severance*.

sequential model—see *model, sequential*.

series, time—see *time series*.

series-wound motor—see *motor, series-wound*.

service—a system or method of providing people with the use of something, for example, transportation.

arterial—generally major (long or heavily patronized) transit routes that operate on principal or major surface arterial streets.

base-period—the level of transit operations during the base period.

charter—transportation service offered to the public on an exclusive basis (either as individuals or as groups). It is provided with a vehicle that is licensed to render charter service and engaged at a specific price for the trip or period of time, usually on a reservation or contractual basis.

charter bus—transportation by bus of a group of people who, pursuant to a common purpose and under a single

service (*continued*)

contract at a fixed price, have acquired the exclusive use of a bus to travel together under an itinerary.

circulator—bus service confined to a specific locale, such as a downtown area or a suburban neighborhood, with connections to major traffic corridors.

city transit—transit serving an urban area, as distinguished from short-haul and regional transit service.

commuter—transportation provided on a regularly scheduled basis during peak travel periods for users commuting to work, school, and similar destinations.

crosstown—nonradial transit service that does not enter the central business district.

curb-to-curb—a service that picks up and delivers passengers at the curb or roadside, as distinguished from door-to-door service. Passenger assistance is not rendered other than for actual boarding and alighting.

demand jitney—see *service, jitney*.

door-to-door—a service that picks up passengers at the door of their place of origin and delivers them to the door of their place of destination. This service may necessitate passenger assistance between the vehicle and the doors. See also *service, curb-to-curb*.

express—service that has fewer stops and a higher operating speed than regular service.

express bus—bus service with a limited number of stops, either from a collector area directly to a specific destination or in a particular corridor with stops en route at major transfer points or activity centers. Express bus service usually uses freeways or busways where they are available.

feeder—1. Local transportation service that provides passengers with connections with a major transportation service. 2. Local transit service that provides passengers with connections to main-line arterial service; an express transit service station; a rail rapid transit, commuter rail, or intercity rail station; or an express bus stop or terminal.

few-to-few—a service that picks up passengers at a limited number of origins and delivers them to a limited number of destinations.

few-to-many—a service that picks up passengers at a few preselected origins, typically activity centers or transfer points, and delivers them to many destinations.

flag stop—1. In paratransit operations, a service accessed by hail. 2. In rail operations, a nonscheduled stop that may be served if proper notice is given by a passenger or prospective passenger.

gather—see *service, many-to-one*.

jitney (demand jitney service)—a route deviation service in which small or medium-sized vehicles, such as large automobiles, vans, or minibuses, are used. The vehicles are usually owned by the drivers and the service is often independently operated. See also *transportation system, jitney*.

level of—see *level of service*.

limited—1. A transit service that operates only during a

service (*continued*)

certain period of the day, or that serves only specific stops (also known as *limited stop service*) or in a specified area, or that serves only certain segments of the population. 2. Line service with some restrictions on boarding and alighting.

limousine (livery service)—1. Demand-responsive public transportation service on an exclusive basis, provided in a vehicle that is licensed to render that service for hire at rates of fare agreed on by the operating licensee, its agent, or the chauffeur and the passengers. 2. Exclusive transportation provided by a chauffeur (usually uniformed) in a large automobile.

line haul—1. Transportation service along a single corridor, without branches, with stops along the way. Usually service is intensive (high capacity) and uses exclusive right-of-way. 2. May also be used to describe express service or even main-line service, as opposed to feeder service.

livery—see *service, limousine*.

local—1. Transit service that involves frequent stops and consequent low average speeds, the purpose of which is to deliver and pick up transit passengers close to their destinations or origins. 2. Transit operation in which all transit units (vehicles or trains) stop at all stations. 3. Transit service in a city or its immediate vicinity, as distinguished from regional transit service or interurban lines.

local bus—a bus service that picks up and discharges passengers at frequent, designated places (stops) on city streets.

many-to-few—a service that picks up passengers at many different origins and delivers them to a few destinations.

many-to-many—a service that picks up passengers at many different origins and delivers them to many different destinations within the service area.

many-to-one (gather service)—a service that collects passengers from many origins and delivers them to a specific point, for example, an office building, train station, or bus stop.

one-to-many (scatter service)—a service that picks up passengers at one point of origin and delivers them to many destinations.

origin-to-destination—service in which the passenger-carrying vehicle will not stop along the way to pick up additional passengers.

owl—transit service provided late at night, usually from midnight to between 4 and 6 a.m.

peak—service during peak periods, usually involving the largest number of transit units (vehicles or trains) in operation at the same time.

point deviation—public transportation service in which the transit vehicle is required to arrive at designated transit stops in accordance with a prearranged schedule but is not given a specific route to follow between these stops. It allows the vehicle to provide curbside service for those who request it. See also *point-to-point deviation*.

service (*continued*)

public automobile—see *transportation system, public automobile service*.

regional rail (RGR)—regional rail passenger service, usually provided by railroad agencies, that consists of electric- or diesel-powered trains on grade-separated railroad lines (sometimes with protected grade crossings); see also *transit system, commuter rail*.

regional transit—long bus or rail transit lines with few stations and high operating speeds. They primarily serve long trips within metropolitan regions, as distinguished from city transit service and short-haul transit service.

Research Information—see *Highway Research Information Service, Railroad Research Information Service, Transportation Research Information Services, and Urban Mass Transportation Research Information Service*.

restoration of—see *restoration of service*.

revenue—1. Transit service excluding deadheading or layovers. 2. Any service scheduled for passenger trips.

route deviation—public transportation service on an exclusive basis that operates along a public way on a fixed route (but not a fixed schedule). The vehicle may deviate from the route occasionally in response to demand for service or to take a passenger to a destination, after which it returns to its route. It is a form of paratransit. See also *service, jitney*.

scatter—see *service, one-to-many*.

school bus—service designed to transport children to or from any regularly conducted public or private school or school-related activities, either on an exclusive or nonexclusive basis.

shoppers' special—service provided during off-peak hours that is designed to carry passengers to or from shopping areas.

short-haul transit—low-speed transit service for circulation within small areas that usually have high travel density, such as central business districts, campuses, airports, exhibition grounds, and other major activity centers.

shuttle—1. Service provided by vehicles that travel back and forth over a particular route, especially a short one, or one that connects two transportation systems or centers, or one that acts as a feeder to a longer route. Shuttle services usually offer frequent service, often without a published timetable. 2. For rail and other guideway systems, a service in which a single vehicle or train operates on a short line, reversing direction at each terminal.

skip-stop—service in which alternate transit units (vehicles or trains) stop at alternate sets of stations on the same route. Each set consists of some joint and some alternate stations.

subscription bus—1. A bus service in which routes and schedules are prearranged to meet the travel needs of riders who sign up for the service in advance. The level of service is generally higher than that of regular passenger

service (*continued*)

service (fewer stops, shorter travel time, and greater comfort), and the buses are usually obtained through charter or contractual arrangements. 2. Commuter bus express service operated for a guaranteed number of patrons from a given area on a prepaid, reserved seat basis.

subscription van—service similar to that provided by a subscription bus, except that the van may be privately owned, leased from a public or private company, or provided by the employer. The driver is usually a member of the group.

subsidized taxi—a taxicab service in which the fares are lower than actual taxi fares and the taxi company is reimbursed the difference. The service may be provided to the general public or to special groups, such as elderly people. Funds for the subsidy can come from a variety of sources, including local taxes or social service agency program funds.

taxicab (*exclusive ride taxi, taxi service*)—demand-responsive public transportation service on an exclusive basis, in a vehicle licensed to render that service; see also *shared ride and service, subsidized taxi*.

Service and Methods Demonstration Program (SMD Program)—a program established and overseen by the Urban Mass Transportation Administration and the Transportation Systems Center in which transit innovations are developed, demonstrated, and evaluated for their potential in providing improved transit service.

service application—see *braking, service*.

service area—see *area, service*.

service attributes—those aspects of a transportation system that affect travel decisions about its use, such as travel time, reliability, comfort (e.g., crowding, standees), cost, ease of use, and safety.

service brake—see *brake, service*.

service braking—see *braking, service; and braking, maximum service*.

service frequency—the number of transit units (vehicles or trains) on a given route or line, moving in the same direction, that pass a given point within a specified interval of time, usually 1 hr; see also *headway*.

service information—see *user information*.

service performance or quality—see definition of *level of service*.

service track miles (kilometers)—see *track miles, service*.

service volume—the maximum number of vehicles that can pass a given point during a specified period while a specified level of service is maintained.

severance pay—see *pay, severance*.

shake-up—see *sign-up*.

share, market—see *market share*.

shared ride—a trip, other than by conventional public transit, on which the passengers enter at one or more points of origin and disembark at one or more destinations and for which each passenger is charged an individual fare. Shared ride taxi service is a way of using taxicabs for paratransit.

share model—see *model, share*.

general—see *model, general share*.

share the work—see *work sharing*.

sharing, work—see *work sharing*.

sharp, running—see *running hot*.

shedding, load—see *load shedding*.

sheet

assignment (*detail sheet, driver mark-up sheet, operator assignment sheet, roster*)—in transit operations, a listing that includes both the vehicles needed by time of day for each division and how many operators are needed.

booking (*bus mark-up sheet*)—a list of scheduled runs posted to inform operators of the buses assigned to them and where the buses are parked.

bus mark-up—see *sheet, booking*.

detail—see *sheet, assignment*.

driver mark-up—see *sheet, assignment*.

headway—a form that contains the scheduled times that transit vehicles are to reach or depart given time points along a route or line.

operator assignment—see *sheet, assignment*.

pick-out (*picking sheet*)—1. A form that gives the out and in times for each scheduled bus on a route or line, including the times that the bus is scheduled to pass a designated relief point. 2. A summary timetable that gives all blocks, in chronological order, that pass by (or initiate service) at a selected point.

terminal—the final timetable of transit unit (vehicle or train) departures from the route or line terminals that is used, in conjunction with the time points and running time, to govern the operation of the units.

terminal layout—a form on which the scheduled departure times of trains from the line terminals are laid out before final adjustment.

trip—1. A sheet on which operating employees record their day's work and may also record the receipts for a run. 2. A record kept of the information required by ordinance or by rule for a shift worked by the driver of a public passenger vehicle in demand-responsive service. It may also be used in line haul or charter service.

shelter—see *transit shelter*.

shift (*tour of duty, stint, trick, turn*)—a part of the daily working schedule of a transit system or its employees.

evening—a shift that ends at or near midnight; see also *shift, swing*.

fixed—a work schedule in which the hours remain the same, week after week, for a group of workers.

graveyard—see *shift, night*.

night (*graveyard shift*)—a shift that starts at or near midnight; see also *shift, swing*.

rotating—a work schedule in which workers change their hours at periodic intervals.

split—a daily shift that is divided into parts separated by periods during which the employee is unassigned and, sometimes, not paid; see also *shift, swing; run, split; and pay, spread time premium*.

shift (*continued*)

swing—1. The fourth or rotating shift used on continuous 7-day or round-the-clock operations. 2. Sometimes used instead of night or graveyard shift to mean work between approximately midnight and 8:00 a.m. or instead of evening shift to mean work ending at approximately midnight. 3. Sometimes used to describe an ordinary split shift.

shift differential (*shift premium*)—additional compensation (cents per hour or percentage of the daily rate) paid to workers employed at other than regular daytime hours.

shine time—see *time, report*.

shoe

brake—see *brake shoe*.

overhead contact—see *overhead contact shoe*.

third-rail—see *third-rail shoe*.

trolley—see *overhead contact shoe*.

shoofly—a temporary track to allow rail operations to bypass construction activities.

shoppers' special service—see *service, shoppers' special*.

short-haul transit service—see *service, short-haul transit*.

short turn—see *turn back*.

shunt—in rail operations, to shift or switch, as a train car; also the railroad switch itself.

shunt motor—see *motor, shunt*.

shuttle-loop transit—see *transit system, shuttle-loop*.

shuttle service—see *service, shuttle*.

shuttle system—see *transit system, shuttle*.

side platform—see *platform, side*.

side track—see *siding*.

sidewalk, moving—see *moving walkway*.

siding (*passing track, side track*)—a track adjacent to a main or a secondary track, for meeting, passing, or storing cars or trains.

private—a siding owned or leased by an individual or firm.

sign

dash—see *dash sign*.

destination—see *destination sign*.

head—see *head sign*.

signal

automatic—a signal that is controlled automatically by certain conditions of the track section that it protects.

automatic block—a system in which signals are actuated automatically by the presence of a train on the track section. Some block signal systems can use an electric circuit to detect the presence of any vehicle, switch positions, broken rail, and so on.

block—a fixed signal installed at the entrance of a block to govern trains entering and using that section of track.

cab—see *control system, cab signal*.

fixed—in rail operations, a signal at a fixed location that indicates a condition that affects the movement of a train.

grade crossing protection—a railroad crossing flashing light signal or automatic gate actuated by the approach of a train at a grade crossing.

signal (*continued*)

wayside—in rail operations, a fixed signal that is located along the track right-of-way.

signal-actuating device—see *pedestrian signal-actuating device* and *vehicle signal-actuating device*.

signal aspect—1. The appearance of a fixed signal conveying an indication, as viewed from the direction of an approaching rail unit. 2. The appearance of a cab signal conveying an indication, as viewed by an observer in the cab of a rail unit.

signal block—see *block*.

signal indication—the information conveyed by a signal.

signal preemption—in highway operations, an automatic or manual device for altering the normal signal phasing or the sequence of a traffic signal to provide preferential treatment for specific types of vehicles, such as buses or trains.

significant impact, finding of no—see *finding of no significant impact*.

sign-up (*bidding runs, mark-up, operator pick, pick, run pick, run picking, shake-up*)—the procedure by which, at regular intervals or when new service or realignments of service are implemented, operators select their regular assignment for an upcoming period (typically several months). The order of selection is usually by operator seniority and is usually specified in union contracts.

simple catenary—see *catenary system*.

simplified network—see *network, spiderweb*.

simulation—a process or technique in which real phenomena, such as vehicle or person movements, are represented mathematically to allow study for planning purposes.

simulation model—see *model, simulation*.

simultaneous model—see *model, simultaneous*.

single-sided linear induction motor—see *motor, single-sided linear induction*.

single-track main line—see *line, single-track main*.

single-unit car—see *car, single-unit*.

sites, symbolic resources—see *symbolic resources sites*.

sketch planning—a transportation analysis procedure that is simpler, faster, and cheaper than using a full procedure and that typically requires less detailed input and provides less specific output.

skimmed or skim tree—see *tree, skimmed*.

skip-stop service—see *service, skip-stop*.

slave unit—see *engine, radio-controlled*.

slot control system, moving—see *control system, moving slot*.

slow order—a location where trains must temporarily travel more slowly than maximum authorized track speed for that location.

small bus—see *bus, small*.

source, dedicated funding—see *dedicated funding source*.

space—in the context of transportation vehicle capacity, a space is a seat or the standing area for one passenger.

defensible—see *defensible space*.

spacing—the distance between consecutive vehicles, measured front to front.

spare board—see *extra board*.

special trackwork—see *trackwork, special*.

speed—see *velocity*.

average—see *velocity, effective*.

cruise—see *velocity, cruise*.

cycle—see *speed, overall trip*.

effective operating—see *speed, overall trip*.

operating—see *speed, running*; and *speed, schedule*.

overall trip (effective operating speed, cycle speed)—in transit operations, the average speed achieved per round trip, including layover time but excluding deadheading time. It is calculated by individual trips, by running time periods, or for the entire schedule.

payroll—a factor used in payroll calculations that is derived by dividing the number of revenue miles (kilometers) operated by the pay hours of the appropriate employee classification, usually rail or bus operators.

running—the highest safe speed at which a vehicle is normally operated on a given roadway or guideway under prevailing traffic and environmental conditions; in some areas, also known as *operating speed*.

schedule—the one-way distance between terminals divided by the scheduled travel time between the terminals; in some areas, also known as *operating speed*.

speed-flow relationship—the relationship between the flow (volume) of units on a transportation facility and the speed of those units. As flow increases, speed tends to decrease.

speed limit, civil—see *civil speed limit*.

spiderweb or spider network—see *network, spiderweb*.

split

directional—see *directional split*.

modal or mode—see *modal split*.

split run—see *run, split*.

split shift—see *shift, split*.

spot, flat—see *flat spot*.

spot time—see *time, layover*.

spread—see *time, spread*.

inside—in scheduling, a time interval beyond which premium (overtime) pay is required.

maximum—the largest permissible spread time for an operator, as specified in a labor contract or agreement.

spread penalty or spread premium time—see *pay, spread time premium*.

spread the work—see *work sharing*.

spread time premium—see *pay, spread time premium*.

staggered work hours—see *work hours, staggered*.

standard error of estimate—a statistical measure of the possible differences between the actual and estimated values of a variable.

standard gauge—see *gauge, standard*.

standard metropolitan statistical area—see *area, standard metropolitan statistical*.

standard rail—see *rail, standard*.

standard urban bus—see *bus, standard urban*.

standing capacity—see *capacity, standing*.

state action plan—see *action plan*.

statement, environmental impact—see *environmental impact statement*.

station—1. An off-street facility where passengers wait for, board, alight, or transfer between transit units (vehicles or trains). A station usually provides information and a waiting area and may have boarding and alighting platforms, ticket or farecard sales, fare collection, and other related facilities. It is also known as a *passenger station*. 2. The location to which operating employees report and from which their work originates. 3. In transportation planning, the location along a cordon line at which interviews are made. 4. In railroad operations, a place designated in the timetable by name, at which a train may stop for traffic or to enter or leave the main track, or from which fixed signals are operated.

all-stop—in transit systems with skip-stop schedule or express service, a station that is served by all scheduled transit units (vehicles or trains).

off-line—a station at which a transit unit (vehicle or train) stops outside of the main track or travel lane so that other units can pass while passengers board and alight.

on-line—a station in which transit units (vehicles or trains) stop on the main track or travel lane. This is the common design, and the term is used only to distinguish this station from off-line stations.

passenger—see *station*.

station accessibility—see *accessibility, station*.

station platform—see *platform*.

statistical area—see *area, consolidated metropolitan statistical; area, metropolitan statistical; area, primary metropolitan statistical; and area, standard metropolitan statistical*.

steam engine—see *engine, steam*.

steel wheel—in rail systems, the specially designed cast or forged steel, essentially cylindrical element that rolls on the rail, carries the weight, and provides guidance for rail vehicles. The wheels are semipermanently mounted in pairs on steel axles and are designed with flanges and a tapered tread to provide for operation on track of a specific gauge. The wheel also serves as a brake drum on cars with on-tread brakes.

stem time—see *time, pull-in; and time, pull-out*.

stint—see *shift*.

stochastic process—a process that involves random variables and a nonreproducible output; see also *deterministic process*.

stochastic trip assignment—see *trip assignment, stochastic*.

stock, rolling—see *fleet*.

stock rail—see *rail, stock*.

stop

far-side—a transit stop located beyond an intersection. It requires that transit units (vehicles or trains) cross the intersection before stopping to serve passengers.

midblock—a transit stop located at a point away from intersections.

stop (continued)

near-side—a transit stop located on the approach side of an intersection. The transit units (vehicles or trains) stop to serve passengers before crossing the intersection.

terminal—a transit stop located at either end of a transit route or line.

transit—an area where passengers wait for, board, alight, and transfer between transit units (vehicles or trains). It is usually indicated by distinctive signs and by curb or pavement markings and may provide service information, shelter, seating, or any combination of these. Stops are often designated by the mode offering service, for example, bus stop, car stop.

stopped time—see *time, stopped*.

storage time—see *time, preparation and storage*.

straight run—see *run, straight*.

straight time—see *time, straight*.

straight time earnings—see *earnings, straight time*.

stratified sampling—see *sampling, stratified*.

stratum—a group of people or households with the same or similar socioeconomic characteristics.

street—see *highway, street, or road*.

arterial—a major thoroughfare, used primarily for through traffic rather than for access to abutting land, that is characterized by high vehicular capacity and continuity of movement.

bus-only (BOS)—a street devoted to bus traffic only.

collector-distributor (collector road)—a street that gathers and disperses traffic between larger arterial highways and smaller streets. It has intersections at grade and provides access to abutting properties.

local access—a street that provides access for pedestrians and vehicles to properties that front on it but is not intended for through traffic.

major—an arterial highway that has intersections at grade and gives direct access to abutting property. Geometric design and traffic control measures are used to expedite the safe movement of through traffic.

mixed mode—a street carrying mixed traffic, that is, having no exclusive transit lanes or priority lanes for transit.

transit—a street reserved for transit vehicles only.

streetcar—an electrically powered rail car that is operated singly or in short trains in mixed traffic on track in city streets. In some areas it is also known as a *trolley car* and, primarily in Europe, as a *tram*.

streetcar operator—see *operator, train*.

streetcar system—see *transit system, streetcar*.

street furniture—equipment placed on the street (off the vehicle lanes), such as lights, benches, signs, bus shelters, kiosks, and plants in containers.

street railway—see *transit system, streetcar*.

street supervisor—see *inspector*.

strip, median—see *median*.

structure

aerial—see *aerial structure*.

fare—see *fare structure*.

integral—see *integral structure*.

route—see *route structure*.

stub terminal—see *terminal, stub*.

study

feasibility—see *feasibility study*.

origin-destination—see *origin-destination study*.

study area—see *area, analysis*.

subballast—a material, superior in composition to the roadbed material, that is spread on the track roadbed before the ballast is spread.

subcontract—a secondary contract undertaking some or all of the obligations of a primary or previous contract.

subscription bus service—see *service, subscription bus*.

subscription van service—see *service, subscription van*.

subsidized taxi service—see *service, subsidized taxi*.

subsidy—in transportation, a grant, usually provided by a government agency, that makes up all or part of the difference between the cost of providing a transportation service and the revenues generated by that service.

provider-side (*operator's subsidy*)—a subsidy paid directly to the provider for supplying certain specified transportation services.

user-side (*user subsidy*)—a subsidy in the form of a sum or a discount paid or applied directly to riders of a transportation service, usually through some type of voucher system.

substitution transfer projects, Interstate—see *Interstate substitution transfer projects*.

suburb—see definition of *area, urbanized*.

suburban coach or suburban transit bus—see *bus, suburban transit*.

subway—1. That portion of a transportation system that is constructed beneath the ground surface, regardless of its method of construction. 2. An underground rail rapid transit system or the tunnel through which it runs. 3. In local usage, sometimes used for the entire rail rapid transit system, even if it is not all beneath the ground surface. 4. A pedestrian underpass.

subway car—see *car, rail rapid transit*.

superelevation—1. In track construction, the design vertical distance that the outer rail is set above the inner rail on a curve. 2. In highway construction, the banking of the roadway on a curve.

supervision, train—see *automatic train supervision*.

supervisor, road, route, or street—see *inspector*.

supply, parking—see *parking supply*.

supported monorail—see *transit system, monorail*.

survey

attitude—a survey that seeks information on attitudes, motives, and opinions.

dwelling unit—see *survey, home interview*.

home interview (*dwelling unit survey*)—a survey in which data are collected at the home in face-to-face interviews. In the case of transportation studies, such

survey (*continued*)

interviews usually include information on household characteristics and travel patterns.

license plate—a survey in which license plate numbers of vehicles at one point are tabulated and compared with a similar listing at another point. It may also be used to establish approximate trip origin by identifying the registration address from motor vehicle records or even to conduct a survey through questionnaires sent to the registration address.

postcard—a survey conducted by distributing a form postcard to travelers or by mailing such a postcard to the home, with a request that the card be completed and mailed back.

quantitative—a survey investigation that gives results in numbers that can be tabulated and projected; see also *qualitative interview*.

roadside—a survey in which highway vehicles are stopped, and drivers, passengers, or both are interviewed to secure information about the trip being made.

telephone—a survey in which data are collected by telephone.

travel—the collection of data that describe the social, economic, and travel characteristics of people who make trips by various modes of transportation.

suspended monorail—see *transit system, monorail*.

suspension—in vehicle construction, the springs, dampers, air bellows, and other devices that absorb shocks and vibration on the vehicle's wheels, reducing or eliminating them before they reach the vehicle body.

swing run—see *run, split*.

swing shift—see *shift, swing*.

switch—1. The movable rails of a turnout that divert the wheels of passing rolling stock from one track to either one of two branching from it. 2. To move rail cars from one place to another within a defined territory, such as an industry, a yard, or a terminal.

electrically locked—a hand-operated switch equipped with a remotely controlled electrical device that restricts the movement of the switch.

track—see *turnout*.

switch heater—a device for melting or clearing snow or ice at rail switches by means of steam, electric, or oil heat or by air jets.

switching—1. A means of changing the route of a guided transit unit (vehicle or train) from one track or guideway to another. 2. The moving of rail cars from one place to another within a terminal or yard.

symbolic resources sites—those cultural or educational areas that are important for their symbolic significance to the community. These could include public and private management areas, historic sites, and unique archaeological, botanical, cultural, and educational areas.

symmetrical monorail—see *transit system, monorail*.

synchronized linear motor—see *motor, linear synchronous*.

synchronous motor—see *motor, synchronous*.

synchronous network control system—see *control system, synchronous network*.

synfuel or synthetic fuel—see *fuel, synthetic*.

system—see *operator and property*.

automated highway—see *automated highway system*.

automatic train control—see *automatic train control system*.

automatic train stop—see *automatic train stop system*.

automatic vehicle location—see *automatic vehicle location system*.

automatic vehicle monitoring—see *automatic vehicle monitoring system*.

belt—see *belt system*.

bus priority—see *bus priority system*.

catenary—see *catenary system*.

command and control—see *command and control system*.

control—see *control system*.

fare collection—see *fare collection system*.

honor—see *fare collection system, self-service, barrier-free*.

management information—see *management information system*.

market information—see *market information system*.

operational—see *operational system*.

planning-programming-budgeting—see *planning-programming-budgeting system*.

power—see *power system*.

propulsion—see *propulsion system*.

prototype—see *prototype system*.

transit—see *transit system*.

transportation—see *transportation system*.

Transportation Planning Support Information—see *Transportation Planning Support Information System*.

trolley—see *transit system, streetcar*.

Urban Transportation Planning—see *Urban Transportation Planning System*.

system management, transportation—see *transportation system management*.

system performance—see *definition of level of service*.

system planning—in transportation, a procedure for developing an integrated means of providing adequate facilities for the movement of people and goods, involving regional analysis of transportation needs and the identification of transportation corridors involved.

T

TACV—tracked air cushion vehicle; see *vehicle, tracked air cushion*.

TDP—Transit Development Program.

TIP—transportation improvement program.

TLV—tracked levitated vehicle; see *vehicle, tracked levitated*.

TPSIS—Transportation Planning Support Information System.

TRB—Transportation Research Board; see *organizations, Transportation Research Board*.

TRIS—Transportation Research Information Services.

TSM—transportation system management.

TSME—transportation systems management element.

TTS—timed transfer system.

TWU—Transport Workers Union; see *union, transit*.

table, trip—see *trip table*.

tag axle—a nonpowered vehicle axle that helps distribute the load.

target market—see *market, target*.

taxicab—a passenger automobile or a specially designed vehicle driven by a professional driver in a for-hire taxi service.

taxicab service—see *service, taxicab*.

taximeter—a mechanical or electrical device in a taxicab that records and indicates a charge or fare calculated according to distance traveled, waiting time, initial charge, number of passengers, and other charges authorized by ordinance or by rule. Some taximeters are part of electronic dispatching systems.

taxi service, subsidized—see *service, subsidized taxi*.

technique

Delphi—see *Delphi process*.

Monte Carlo—see *Monte Carlo technique*.

semantic differential—see *semantic differential technique*.

telephone survey—see *survey, telephone*.

terminal—1. The end station or stop on a transit line or route, regardless of whether special facilities exist for reversing the vehicle or handling passengers; also known as a *terminus*. 2. An assemblage of facilities provided by a railroad or intercity bus service at a terminus or at an intermediate location for the handling of passengers and the receiving, classifying, assembling, and dispatching of trains or dispatching of buses; also known as a *depot*.

off-street—a transit terminal or turnaround point for transit vehicles that is located away from other vehicular traffic.

stub—a dead-end terminal in which the entering rail (or other guided) transit unit must depart by the same guideway on which it entered. Because no loop is provided, a bidirectional transit unit (vehicle or train) is necessary.

terminal layout sheet—see *sheet, terminal layout*.

terminal sheet—see *sheet, terminal*.

terminal stop—see *stop, terminal*.

terminal time—see *time, terminal*.

termination pay—see *pay, severance*.

terminus—see *terminal*.

territory, train control—see *train control territory*.

theoretical line capacity—see *capacity, theoretical line*.

third rail—see *rail, third*.

third-rail shoe—a metallic sliding contact attached to the trucks of electric rail vehicles for the purpose of collecting current from the third-rail distribution system.

3C process—a process for planning urban transportation facilities and services that is required by the Federal Aid Highway Act of 1962 and the Urban Mass Transportation Act of 1964, as amended, in urbanized areas. The three Cs stand for a continuing, comprehensive, and cooperative transportation planning process.

throughput—1. The volume of vehicles passing or people transported past a point or series of points during a given period of time. 2. Traffic.

through routing—the practice of joining the ends of radial transit routes to travel through downtown instead of having each route turn back in the downtown and return to its origin.

ticket—1. A printed card or piece of paper that gives a person a specific right to ride on a train or transit vehicle. 2. To provide a ticket or tickets.

commutation—see *commutation ticket*.

tie—see *cross-tie*.

time

access—the time elapsed on a trip from the moment of leaving the point of origin to the moment of boarding a vehicle.

allowance (*allowed time, bonus time, dead time, hold time*)—time for which an operator is paid even though the hours have not been worked or have not been worked in operating a transit unit. Forms of allowance time are pad time, report time, turn-in time, and sometimes, travel time and intervening time. See also *allowances*.

bonus—see *time, allowance*.

clear—see *time, turn-in*.

dead—see *time, allowance*.

deadhead (*not-in-service time*)—time spent moving a revenue vehicle in nonrevenue service.

delay—the amount of time by which a transit unit (vehicle or train) in service is delayed from its scheduled time.

down—see *downtime*.

dwell—the time a transit unit (vehicle or train) spends at a station or stop, measured as the interval between its stopping and starting.

egress—the time elapsed on a trip from the moment of alighting from a vehicle to the moment of arriving at the point of destination.

excess—time delay associated with travel to or between major transit routes, for example, time spent walking, waiting, or transferring.

guarantee—the minimum amount of contractually stipulated time employees must be paid for working. The weekly guarantee time, for example, is usually 40 hr, whether or not the employee actually works that long.

time (continued)

hold—see *time, allowance*.

intervening—the time between two pieces of paid work for which the employee is also paid; sometimes called *paid break*.

interzonal travel—the travel time between any two zones, including the terminal time at each end of the trip.

intrazonal travel—the travel time for trips that begin and end in the same zone, including the terminal time at each end of the trip.

journey (*operator's travel time*)—in transit operations, a time allowance for being required to report for work at a point removed from the home terminal or to return without passengers after completing a run; see also *pay, deadheading*.

layover (*recovery time, relay time, spot time, turn-around time*)—time built into a schedule between arrivals and departures, used for the recovery of delays and preparation for the return trip. The term may refer to transit units (also known as *vehicle layover*) or operators.

linked trip (*overall travel time, total travel time*)—in transportation planning, the time duration of a linked trip, that is, from the point of origin to the final destination, including waiting and walking time at transfer points and trip ends.

makeup—see *time, pad*.

not-in-service—see *time, deadhead*.

operating—the actual time required for a transit unit (vehicle or train) to move from one point to another, including making stops.

operator's travel—see *time, journey*.

outside—see *time, spread*.

overall travel—see *time, linked trip*.

pad (*makeup time, premium time*)—time for which an operator is paid to meet a guaranteed minimum, even though the hours have not been worked; a form of allowance time.

penalty—the amount of time by which a run exceeds its stipulated length and for which special allowances must be paid.

platform—1. The period during which an operator is charged with the operation or care of a transit unit (vehicle or train), including operating time in revenue service and deadhead, layover, and other time that the unit may be in operation but not in passenger service. 2. The time a transit unit is in revenue service. 3. The time the operator is actually on the assigned transit unit; also known as *work time*.

premium—see *time, pad*.

preparation and storage—the time in minutes paid to an operator to prepare or store the transit unit when pulling out and in, that is, report time and turn-in time combined.

pull-in—1. In transit operations, the time at which the transit unit returns to the yard or garage; see also *time, turn-in*. 2. In some transit operations, the deadhead time

time (*continued*)

assigned to move a transit unit (vehicle or train) from its last scheduled stop to the storage area; also known as *stem time*.

pull-out—1. In transit operations, the scheduled time at which the transit unit leaves the yard or garage; see also *time, report*. 2. In some transit operations, the deadhead time assigned to move a transit unit (vehicle or train) from the storage area to its first scheduled stop; also known as *stem time*.

recovery—see *time, layover*.

relay—see *time, layover*.

relief—the time at which operators report to specified points (relief points) to relieve and be relieved.

report—1. The time at which operators must report if they are to work an assignment. 2. The time at the beginning of a run that operators use to prepare themselves for duty and their vehicles for service before leaving the yard or garage. This time, usually 5 or 10 min, may be paid or unpaid. It is also frequently known as *preparation time, pull-out time*, or (only if paid) *report time allowance*. See also *time, pull-out*. 3. In some properties, the time spent by an operator waiting for an assignment or protecting service in event of absence of another operator; also known as *shine time*.

response—in demand-responsive operations, the time between a passenger's request for service and the passenger pickup.

running—the actual time required for a transit unit (vehicle or train) to move from one point to another, excluding time for stops.

shine—see *time, report*.

spot—see *time, layover*.

spread (*spread, outside time*)—total elapsed time from the beginning to the end of a day's assignment, including all breaks, time between runs, travel time, and deadheading.

spread premium—see *pay, spread time premium*.

stem—see *time, pull-in*; and *time, pull-out*.

stopped—time on a trip spent stationary because of the stoppage of other traffic.

straight—time worked at a regular or base rate, as distinguished from overtime.

terminal—1. For passengers, the time required at the ends of trips to unpark and park their private vehicles, including any necessary walking time. 2. For rail vehicles, the time allowed at a terminal between arrival and departure for turning vehicles, recovering delays, and preparing for the return trip. 3. The time required for a passenger to pass through a terminal when there is a change of mode.

total travel—see *time, linked trip*.

transfer—the time required to effect a change of mode or to transfer between routes or lines of the same mode.

trip—see *time, linked trip*; and *time, unlinked trip*.

turnaround—see *time, layover*.

time (*continued*)

turn-in—the time at the end of a run that allows the operators to clear their responsibilities (e.g., read farebox, turn in tickets) and prepare their vehicles for storage. The time may be paid or unpaid and may or may not be included in platform time. It is also frequently known as *clear time, pull-in time, or storage time*; see also *time, pull-in*.

unlinked trip—in planning, the time duration of an unlinked trip, that is, one made on a single vehicle.

wait—the time spent waiting for a transit vehicle.

weighted—a measure of travel time where certain components (e.g., wait time) are factored upward.

work—see *time, platform*.

timed connection or transfer—see *transfer, timed*.

timed transfer system (TTS)—a transit network consisting of one or more nodes (transit centers) and routes or lines radiating from them. The system is designed so that transit vehicles on all or most of the routes or lines are scheduled to arrive at a transit center simultaneously and depart a few minutes later; thus transfers among all the routes and lines involve virtually no waiting. TTS is typically used in suburban areas and for night service; in other words, for those cases in which headways are long (10–60 min). Transit centers (also known as *timed transfer focal points*) are ideally located at major activity centers, such as suburban towns, campuses, and shopping centers.

time-of-day fare—see *fare, time-of-day*.

time-of-day pricing—see *pricing, time-of-day*.

time off—the clock time recorded when an operator's duties are completed.

time on—the clock time recorded when an operator actually reports, before pull-out time.

time point—a point on a line or route for which the time that transit units (vehicles or trains) are scheduled to pass is specified; usually, the leaving time is used.

time series—data collected by observing the same phenomenon at several different times.

time series analysis—an analytic approach that separates the effects of trend, season, and cycle and is useful in evaluating demand.

timetable—1. Usually refers to a printed schedule for the public. 2. A listing of the times at which transit units (vehicles or trains) are due at specified time points; also known as a *schedule*. 3. In railroad operations, the authority for the movement of regular trains subject to the rules. It contains classified schedules with special instructions for the movement of trains and locomotives.

token—a prepaid, nonmonetary stamped piece used in payment for transit service, usually one trip.

torque—the twisting force required to turn a bolt or a rotating shaft.

total operating revenue—see *revenue, total operating*.

total travel distance—see *distance, linked trip*.

total travel time—see *time, linked trip*.

total vehicle capacity—see *capacity, vehicle*.

tour of duty—see *shift*.

trace tree—see *tree, trace*.

track—1. An assembly of rails, supporting ties, and fastenings over which rail vehicles travel. 2. A linear cam or way that physically guides (and usually supports) any matching vehicle used for transportation. 3. The width of a wheeled vehicle from wheel to wheel, usually measured between the outsides of the rims. 4. The distance between the centers of the tread of parallel wheels, as of an automobile.

electrified—rail track equipped for the operation of electrically propelled vehicles that receive electric power from a conduit placed along the track's entire length. The conduit is usually an overhead wire or third rail.

passing—see *siding*.

side—see *siding*.

track brake—see *brake, track*.

track car—see *car, track*.

track circuit—an electrical circuit that makes use of both rails to detect train occupancy of the track and, in response, to actuate signals, train control devices, and grade crossing protective equipment.

track crossing—see *crossing, track*.

tracked air cushion vehicle—see *vehicle, tracked air cushion*.

tracked levitated vehicle—see *vehicle, tracked levitated*.

track gauge—see *gauge, track*.

track instrument—a device in which the vertical movement of the rail or the blow of a passing wheel operates a contact to open or close an electric circuit.

track miles (track kilometers)—the sum of the one-way linear miles (kilometers) of all trackage in a system, including all main track and trackage in yards, car barns, switches, and turnouts.

revenue (revenue track kilometers)—the number of miles (kilometers) of track used in passenger-carrying service.

service (service track kilometers)—the number of miles (kilometers) of track used exclusively in nonrevenue service.

track relay—a relay that receives all or part of its operating energy through conductors (of which the track rails are an essential part) and that responds to the presence of a train on the track.

track schedule—see *schedule, track*.

track special work—see *trackwork, special*.

track switch—see *turnout*.

track trip—a device that is located near the track and interconnected with the signal system so that it triggers the emergency brakes of any train that passes when the signal is red.

trackwork—the rails, switches, frogs, crossings, fastenings, pads, ties, and ballast or track-support slab over which rail cars are operated.

special (track special work)—all rails, track structures, and fittings, other than plain unguarded track, that is neither curved nor fabricated before laying.

tract, census—see *census tract*.

traction motor—see *motor, traction*.

tractive effort (tractive force)—the force exerted by a locomotive or other powered vehicle on its driving wheels. It is equal to the weight on the driving wheels times the coefficient of adhesion.

trade union—see *union*.

traffic—in traffic engineering and transportation planning, the vehicles, people, or both that pass a specified point during a given period.

annual average daily (AADT)—daily traffic that is averaged over a calendar or fiscal year.

annual average weekday (AAWDT)—daily traffic that is averaged over a calendar or fiscal year and that includes only weekdays (Mondays through Fridays). It may also exclude holidays.

average daily (ADT)—the average number of vehicles that pass a specified point during a 24-hr period.

converted—a component of the normal traffic pattern that has made a change in its usual mode of travel, for example, automobile drivers converted into public transit users because of street congestion and lack of parking facilities.

diverted (diverted demand)—a component of traffic that has changed from its previous path of travel to another route without a change in origin, destination, or mode of travel, for example, traffic diverted from a major street to a new expressway, roughly parallel to the street, because of savings in time or distance.

generated (generated demand)—a general term that can be applied to any part of the traffic created by one or more land uses.

induced (induced demand)—the added component of traffic volume that did not previously exist in any form but that results when new or improved transportation facilities are provided, for example, trips to a shopping center by the transit dependent when transit service to the shopping center is started.

mixed (mixed flow traffic)—traffic that contains different vehicle categories or different modes.

passenger—see *passenger flow*.

traffic assignment—see *trip assignment*.

traffic assignment zone (traffic zone)—in planning, a division of a study area that is represented by a centroid and used for traffic assignment purposes.

traffic checker—see *checker*.

traffic control device—a sign, signal, marking, or other device placed on or adjacent to a street or highway, by authority of a public body or official that has jurisdiction, to regulate, warn, or guide traffic.

grade crossing—see *grade crossing traffic control device*.

traffic control system, centralized—see *control system, centralized traffic*.

traffic count—a record of the number of vehicles, people aboard vehicles, or both, that pass a given checkpoint during

a given time period. It may be classified by type of vehicle. See also *count*.

traffic model—see *model, traffic*.

traffic operations, mixed—see *mixed traffic operations*.

traffic volume flow map—see *flow map*.

traffic zone—see *traffic assignment zone*.

trailer car—see *car, trailer*.

train—1. Two or more transit vehicles physically connected and operated as a unit; see also *transit unit*. 2. One or more locomotives or self-propelled rail cars, with or without other cars but with marker lights. 3. On a headway sheet, a single transit unit (vehicle or train) and all the scheduled work that it performs during the operating day.

elephant—a train of two or more small passenger conveyances, which may be open or enclosed, pulled slowly by a power tractor unit. The trailer units follow essentially the same path as that taken by the tractor unit. Elephant trains are typically operated at major activity centers, such as expositions or boardwalks.

local—a train that stops at every station on the line; see also *service, local*.

push-pull—a locomotive and a set of cars equipped with one or more cab cars from which the locomotive can be controlled. The train is either pulled and controlled from the locomotive in the conventional manner or pushed by the locomotive and controlled from the leading car.

train berth—in rail operations, the space designated for a train of given length to occupy when it is stopped at a station platform, in a terminal, on a transfer track, or at some other designated place.

train card—see *paddle board*.

train control—see *automatic train control system*.

train control system

continuous—see *control system, continuous train*.

manual—see *control system, manual train*.

train control territory—the portion of a railroad division or district that is equipped with an automatic train control system.

train density—1. The number of trains that can be operated safely over a segment of railroad in each direction during a 24-hr period. 2. The average number of trains that pass over a specified section of railroad in a specified period.

train describer—a document or display device that gives information about the origin, destination, class, or character of trains, locomotives, or rail cars that are moving or to be moved between given points.

train line circuit—see *electric train line circuit*.

trainlined brake—see *brake, continuous*.

train operation—the way in which a train is operated, for example, automatic with automatic overspeed control, or manual with either automatic or manual speed control, or skip-stop.

automatic—see *automatic train operation*.

train operator—see *operator, train*.

train protection, automatic—see *automatic train protection*.

train stop system, automatic—see *automatic train stop system*.

train supervision, automatic—see *automatic train supervision*.

tram—see *streetcar*.

tramway—see *transit system, streetcar*.

aerial—see *aerial tramway*.

transducer—an electrical or mechanical device that converts physical motion into electrical impulses that can be easily counted and processed by a computer. Examples of transducers include fuel flow meters, vehicle odometers, and passenger-counting infrared beams.

transfer—1. A passenger's change from one transit unit (vehicle or train) or mode to another transit unit or mode. 2. A slip of paper, card, or other instrument issued to passengers (either free or with a transfer fee) that gives the right to change from one transit unit or mode to another according to certain rules that may limit the direction of travel or the time in which the change may be made.

emergency—a transfer issued to passengers under emergency conditions, for example, a transfer issued at the point of a break in service or to a passenger who caught the wrong bus. It does not conform to the rules for normal transfer and therefore may permit continuation of a ride by an alternate route or in a reverse direction.

free—a transfer that requires no additional payment.

paid—a transfer that requires an additional payment (*transfer fee*), either at the time of purchase or at the time of boarding another transit unit (vehicle or train).

paid area—a transfer in a controlled area, within which all patrons will have paid a fare, that allows boarding of transit units (vehicles or trains) through all doors, without fare inspection.

timed—1. A transfer that is valid only for a specified time. 2. The scheduling of intersecting transit routes so that they are due to arrive at a transfer point simultaneously, eliminating waiting time for transfer passengers; also known as a *timed connection*. See also *timed transfer system*.

transfer center—see *transit center*.

transfer facility, intermodal—see *transit center*.

transfer fee—see definition of *transfer, paid*.

transfer passenger—see *passenger, transfer*.

transfer projects, Interstate substitution—see *Interstate substitution transfer projects*.

transfer time—see *time, transfer*.

transit, mass or public—see *public transit*.

transit accessibility—see *accessibility, transit*.

transit agency or authority—see *transit district*.

transit bus—see *bus, standard urban*; and *bus, suburban transit*.

transit car—see *car, rail rapid transit*.

transit center—a transit stop or station at the meeting point of several routes or lines or of different modes of transportation. It is located on or off the street and is designed to handle the movement of transit units (vehicles or trains) and

the boarding, alighting, and transferring of passengers between routes or lines (in which case it is also known as a *transfer center*) or different modes (also known as a *modal interchange center* or an *intermodal transfer facility*).

transit dependent—having to rely on transit services instead of the private automobile to meet one's travel needs; see also *rider, captive; rider, captive transit; and transportation disadvantaged*.

Transit Development Program (TDP)—a short-term (5-year) program that outlines the intended development of transit in any given year for that period. It includes a detailed program of capital equipment acquisition, system management, and operations.

transit district—a geographical or political division created specifically for the single purpose of providing transportation services. It is a separate legal entity and usually possesses the authority to impose a property tax. Such political divisions may also be known as a *transit agency* or *transit authority*; see also *property*.

transit facilities, exclusive—see *exclusive transit facilities*.

transit lane, exclusive or reserved—see *lane, exclusive transit*.

transit mode—see *mode, transit*.

Transit Research and Development Program—see *National Cooperative Transit Research and Development Program*.

transit shelter—a building or other structure constructed at a transit stop. It may be designated by the mode offering service, for example, *bus shelter*. A transit shelter provides protection from the weather and may provide seating or schedule information or both for the convenience of waiting passengers.

transit stop—see *stop, transit*.

transit street—see *street, transit*.

transit system—the facilities, equipment, personnel, and procedures needed to provide and maintain public transit service.

accessible—a transit system that can transport any mobile person, including those who are physically disabled, and in which the vehicles and stops or stations are designed to accommodate patrons who are confined to wheelchairs.

automated guideway (automated guided transit, AGT)—any guided transit mode with fully automated operation (i.e., no crew on the transit units). The term usually refers, however, only to guided modes with small and medium-sized vehicles that operate on guideways with exclusive right-of-way. The term includes the personal rapid transit concept and group rapid transit or people mover systems.

bus rapid—an inexact term describing a bus operation that is generally characterized by operation on an exclusive or reserved right-of-way that permits high speeds. It may include reverse lane operations on limited access roads. Strictly speaking, rapid transit designates operations entirely on exclusive right-of-way; thus bus rapid transit might be more appropriately called semi-rapid.

transit system (continued)

capsule—a system of small transit units or individual capsules propelled by belts, rollers, or cables.

commuter rail—a passenger railroad service that operates within metropolitan areas on trackage that usually is part of the general railroad system. The operations, primarily for commuters, are generally run as part of a regional system that is publicly owned or by a railroad company as part of its overall service. In some areas it is called *regional rail*.

continuous—a system that provides continuous movement, for example, a moving belt or escalator. The whole system or portions of it may operate at variable speeds.

dual-mode—a broad category of systems wherein vehicles may be operated in both of two different types of operation or propulsion, for example, manually steered and guided, on highways and on guideways, or with diesel and electric traction.

fixed guideway—1. A transportation system composed of vehicles that can operate only on their own guideways, which were constructed for that purpose. Examples are rapid rail, light rail, and monorail. 2. Federal usage of the term in funding legislation also includes bus priority lanes, exclusive right-of-way bus operations, trolley coaches, and ferryboats as fixed guideway transit.

group rapid (GRT)—an automated guideway transit system that uses medium-sized vehicles operating automatically as single units or coupled trains on exclusive rights-of-way with special guideways. The vehicles are usually rubber tired and electrically propelled. The systems are sometimes referred to as *people mover systems*.

heavy rail—see *transit system, rail rapid*.

interurban—electric rail transit service between cities and towns that are fairly close to each other, specifically, 9–50 mi (15–80 km). This mode usually operates on private rights-of-way that are longitudinally physically separated (by curbs, barriers, grade separation, etc.) from other traffic but that have grade crossings for other vehicles and pedestrians, including regular street intersections. Sections of line in cities may run along streets or median strips.

light rail (LRT)—as defined by the TRB Subcommittee on Light Rail Transit, a metropolitan electric railway system characterized by its ability to operate single cars or short trains along exclusive rights-of-way at ground level, on aerial structures, in subways, or occasionally, in streets, and to board and discharge passengers at track or car floor level.

light rail rapid (LRRT)—light rail transit with exclusive, grade-separated right-of-way for the entire system. It may have low- or high-level platforms and visual or signal control.

major activity center (MAC system)—a transit system that provides service for short trips within small, densely populated major activity centers, such as shopping centers and downtown areas.

transit system (*continued*)

monorail—a transit system consisting of vehicles supported and guided by a single guideway (rail or beam), usually elevated. The basic types are as follows: *supported*, in which vehicles straddle the guideway or are laterally supported by it; and *suspended*, in which vehicles hang directly below the guideway (*symmetrical monorail*) or to one side of it (*asymmetrical monorail*). Supported monorails are stabilized by gyro, overhead rails, or lateral guidewheels on both sides of the beam (*saddle monorail*).

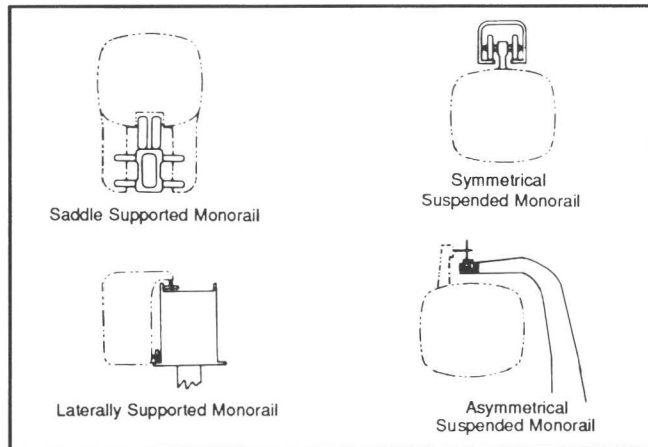

personal rapid (PRT)—a theoretical concept for an automated guideway transit system that would operate small units (two to six passengers) under computer control over an elaborate system of guideways. Off-line stations would provide demand-responsive service (except, perhaps, during peak periods) with headways of 3 sec or less. Individuals or small acquainted groups would use a unit to travel between origin and destination stations without stopping.

pre-metro—a light rail transit system designed with provisions for easy conversion to rail rapid transit.

publicly owned—a transit system owned by any municipality, county, regional authority, state, or other governmental agency, including a system operated or managed by a private company under contract to the government agency owner.

rail—any of the family of transit modes with rail technology. The major ones, generally in ascending order of performance, are streetcars, light rail transit, rail rapid transit, and commuter or regional rail.

rail rapid (heavy rail transit, rapid rail transit)—a transit system that generally serves one urban area, using high-speed, electrically powered passenger rail cars operating in trains in exclusive rights-of-way, without grade crossings (Chicago is an exception) and with high platforms. The tracks may be in underground tunnels, on elevated structures, in open cuts, at surface level, or any combination thereof. Some local terms used for rail rapid transit are *the elevated*, *the metro*, *the metropolitan railway*, *the rapid*, *the subway*, *the underground*.

semi-metro—a light rail transit system that uses exclusive right-of-way for much of its length, usually at sur-

transit system (*continued*)

face grade but occasionally in tunnels or on aerial structures.

shuttle—a transit system that is characterized by a back-and-forth operation, usually over a short distance.

shuttle-loop (SLT)—an automated guideway transit system in which transit units (vehicles or trains) operate along shuttle or loop guideways with few or no switches. It usually has on-line stations.

streetcar (street railway, tramway, trolley system)—a street transit system consisting of electrically powered rail vehicles operating in one- to three-car transit units, mostly on surface streets with mixed traffic.

transit system availability—a measure of the capability of a transit system to be used by potential passengers, including such factors as the hours the system is in operation, route spacing, and accessibility to the physically handicapped.

transit union—see *union*, *transit*.

transit unit—one or more transit vehicles coupled and operated together. The term includes single vehicles (bus, rail, or other guideway) and multicar trains (rail or other guideway).

bidirectional or double-ended—see *double-ended transit unit*.

transitway—a dedicated right-of-way, most commonly in a mall, that is used by transit units (vehicles or trains), usually mixed with pedestrian traffic.

transport, conventional rail—see *conventional rail transport*.

transportation

balanced—see *transportation system, balanced*.

department of—see *organizations, department of transportation*; and *U.S. Government, Department of Transportation*.

elderly and handicapped—see definition of *elderly and handicapped*.

intercity—see *intercity transportation*.

mass—see *mass transportation*.

private—see *private transportation*.

public—see *public transportation*.

purchased—see *purchased transportation*.

urban public—see *urban public transportation*.

transportation brokerage—1. Coordination of transportation services in a defined area. The transportation broker may centralize vehicle dispatch, record keeping, vehicle maintenance, and other functions under contractual arrangements with agencies, municipalities, and other organizations. 2. A method of matching travelers with a variety of transportation providers through use of central dispatching and administrative facilities.

transportation disadvantaged (low-mobility group)—people whose range of transportation alternatives is limited, especially in the availability of relatively easy-to-use and inexpensive alternatives for trip making. Examples include the young, the elderly, the poor, the handicapped, and those who do not have automobiles. See also *transit dependent; rider, captive*; and *rider, captive transit*.

transportation facilities—see *accessible transportation facilities*.

transportation handicapped—see *handicapped*.

transportation improvement program (TIP)—as stated in FHWA-UMTA joint regulations that govern transportation programming, a prioritized program of transportation projects to be implemented in appropriate stages over several years (i.e., 3–5 yr). The projects are recommended from those in the transportation systems management element and the long-range element of the planning process. This program is required as a condition for a locality to receive federal transit and highway grants.

transportation improvements, low-capital—see *low-capital transportation improvements*.

transportation interface—the point or facility at which two or more modes of transportation meet or at which two or more transit system routes or lines meet.

transportation modeling system, urban—see *urban transportation modeling system*.

transportation planning process, urban—see *urban transportation planning process*.

Transportation Planning Support Information System (TPSIS)—a centralized system for gathering transportation data.

Transportation Planning System, Urban—see *Urban Transportation Planning System*.

Transportation Research Board—see *organizations, Transportation Research Board*.

Transportation Research Information Services (TRIS)—a national network of transportation research information services developed by the Transportation Research Board. TRIS consists of the Air Transport Information Service, Highway Research Information Service, Maritime Research Information Service, Railroad Research Information Service, and Urban Mass Transportation Research Information Service. The TRIS database is vended by Dialog Information Services.

Transportation Study, Nationwide Personal—see *Nationwide Personal Transportation Study*.

transportation system—1. A system that provides for the movement of people, goods, or both. 2. A coordinated system made up of one or several modes serving a common purpose, the movement of people, goods, or both.

air cushion—a surface transportation system that uses vehicles that are supported above the guideway by a thin layer (cushion) of air.

balanced—a system in which the facilities and services of different transportation modes are treated as parts of a single system and each mode is planned in a manner that most effectively uses its special elements in combination with other elements to provide mobility for people in the most effective manner.

demand-actuated—see *transportation system, demand-responsive*.

demand-responsive (demand-actuated transportation system, demand response transportation system)—a

transportation system (continued)

transportation system characterized by flexible routing and scheduling of relatively small vehicles to provide door-to-door, curb-to-curb, or point-to-point transportation at the user's demand. It operates on the street and highway system (e.g., taxicab) or, in concept, on a guideway network.

dial-a-ride (DAR)—a demand-responsive system in which curb-to-curb transportation is provided to patrons who request service by telephone, either on an ad hoc or subscription basis. It is also known as dial-a-bus (DAB) when buses are the vehicles used.

fixed route—a system in which vehicles follow one or more routes. It is different from modes of transportation such as taxicabs or demand-responsive transportation, in which each trip may differ in its origin and destination.

high-speed ground (HSGT)—a guided transportation system with exclusive right-of-way and vehicles intended to serve a densely traveled corridor at cruise speeds of 124 mph (200 km/h) and greater.

jitney—public transportation rendered in small or medium-sized vehicles that are licensed to render that service at a fixed rate or fare for each passenger. The vehicles operate on fixed routes along public ways, from which they may deviate from time to time in response to a demand for service or to take passengers to their destinations, thereafter returning to the fixed route. The scheduling and organization of this type of system vary among jurisdictions. It is used extensively in cities of developing countries that have inadequate transit service. See also *service, jitney*.

pallet—a system that uses platforms or pallets to carry, for example, conventional automobiles or cabins automatically on high-speed guideways.

pallet-pod—a pallet system that uses pods consisting of passive vehicles that are transferred from line to line by an automated conveying mechanism.

pedestrian assist—a system of moving walkways or other devices designed to aid pedestrian movement.

public automobile service (PAS)—a system designed to facilitate short-distance urban trips at modest speed through the use of a fleet of small electric automobiles, available at self-service stands located every few blocks, for rental by the trip to accredited drivers.

tube—a proposed system in which vehicles (usually non-powered vehicles propelled by differential air pressures, gravity, or both) operate within a sealed tube at extremely high speeds.

urban—the system of transportation elements (both private and public) that provides for the movement of people and goods in an urban area. The components include transit systems, paratransit services, and highway or road systems, including private vehicles and pedestrians.

transportation system management (TSM)—that part of the urban transportation planning process undertaken to improve the efficiency of the existing transportation system. The intent is to make better use of the existing transportation system by using short-term, low-capital transportation

improvements (LCTI) that generally cost less and can be implemented more quickly than system development actions.

transportation system management alternative (*low-capital alternative, no-build alternative, TSM alternative*)—the planning option of not building a new transportation facility, such as a new highway or rail system, but instead improving the already existing transportation system, for example, by making streets one way or increasing public transportation services; see also *no-action alternative* and *transportation system management*.

transportation systems management element (TSME)—as provided in FHWA-UMTA joint regulations governing transportation programming, the TSME of a transportation plan provides for the short-range transportation needs of the urbanized area by making efficient use of existing transportation resources and providing for the movement of people in an efficient manner. It identifies traffic engineering, public transportation, regulatory, pricing, management, operational, and other improvements to the existing system but does not include new facilities or major changes in existing facilities.

Transport Workers Union—see *union, transit*.

travel demand

latent—the number of trips that would probably be made during a defined period of time by vehicles or passengers along a particular route or corridor under specified conditions, for example, at certain fare or service levels.

total—the potential number of trips that would probably be made by people who do not now travel because of inconvenience, unawareness, inaccessibility, or unavailability of present modes or the inability to use them.

travel distance—see *trip distance, linked*.

travel pay—see *pay, deadheading*.

travel survey—see *survey, travel*.

travel time

operator's—see *time, journey*.

overall or total—see *time, linked trip*.

travel time factor—an empirically determined set of factors in which each factor expresses the effect of one particular travel time increment of trip interchanges between zones.

travel time pay—see *pay, deadheading*.

travel time ratio—the ratio that compares travel times between a pair of points via two different modes or facility types.

tread

rail—see *rail tread*.

wheel—see *wheel tread*.

treatment, preferential—see *preferential treatment*.

tree—in planning, a graph or network in which one node is joined to every other node by a unique path. A shortest path tree is a record that shows the shortest routes and travel times from a given zone to each node in the travel network. The tracing of routes has a strong resemblance to the trunk and branches of a tree.

skimmed (*skim tree*)—in planning, a series of records, compiled by using data obtained from the tree records,

tree (*continued*)

that lists the minimum travel time, cost, or distance between each pair of zones.

trace—in planning, the sequence of nodes that defines the links that make up the shortest path between two zones.

trick—see *shift*.

trip—1. A one-way movement of a person or vehicle between two points for a specific purpose; sometimes called a *one-way trip* to distinguish it from a round trip. 2. In rail operations, a mechanical lever or block signal that, when in the upright position, activates a train's emergency braking system. 3. The movement of a transit unit (vehicle or train) in one direction from the beginning of a route to the end of it; also known as a *run*.

external-external—a trip that has both its origin and destination outside the study area but that involves travel through the study area.

external-internal—a trip that has either its origin or destination inside the study area.

home-based—a trip that has either its origin or destination at the traveler's residence.

inbound—a trip toward the central urban area, into the central business district, or to a timed transfer point or major activity center.

internal-internal—a trip that has both its origin and its destination inside the study area.

interzonal—a trip that involves travel between two zones.

intrazonal—a trip that has both its origin and its destination in the same zone.

linked (*linked journey, linked passenger trip*)—a trip from the point of origin to the final destination, regardless of the number of modes or vehicles used.

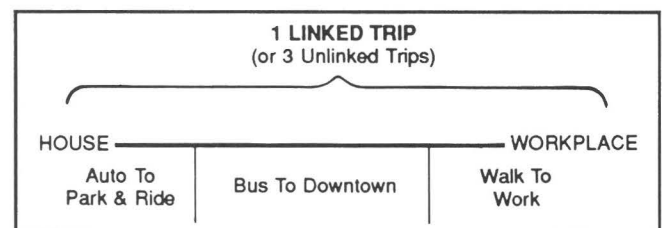

non-home-based—a trip that has neither its origin nor its destination at a residence.

one-way—see *trip*.

outbound—a trip away from the central urban area, out of the central business district, or away from a timed transfer point or major activity center.

part—a run added to the beginning or end of a regular run.

passenger—one passenger making a one-way trip from origin to destination.

person—a trip made by a person by any mode or combination of modes for any purpose.

round—the movement of a person or a vehicle from a point of origin to a destination and then back to the same point of origin.

track—see *track trip*.

trip (*continued*)

unlinked—1. A trip made in a single vehicle. 2. The boarding of one transit vehicle in revenue service; also known as an *unlinked passenger trip*. 3. Any segment of a linked trip.

vehicle—the one-way movement of a vehicle between two points.

trip assignment (*flow distribution, traffic assignment*)—in planning, a process by which trips, described by mode, purpose, origin, destination, and time of day, are allocated among the paths or routes in a network by one of a number of models; see also *urban transportation modeling system* and *model, sequential*.

all-or-nothing—a trip assignment technique that allocates the total number of trips between two zones to only one path between them, usually chosen on the basis of minimum travel time.

capacity restraint—an iterative process by which the volume allocated to a route is compared with the capacity of that route and the speed of the route is adjusted accordingly to reflect its characteristics of speed, volume, and density. New minimum time paths are calculated at the beginning of each iteration.

deterministic—a trip assignment process without probabilistic elements, that is, one that will always produce the same outputs when given the same inputs.

diversion—a trip assignment technique that allocates trips to alternate routes on the basis of the relative times or distances (or both) involved.

incremental—a trip assignment technique that approximates flow equilibrium by loading fixed increments of traffic and adjusting link speeds to reflect relationships of speed, volume, and density. Minimum time paths are calculated after each incremental assignment.

proportional—a trip assignment process that is not all or nothing.

stochastic—a probabilistic trip assignment technique that allocates trips with deviation from the minimum time route on the basis of differences in travel time.

trip attractions—in planning, the number of trips, daily or for a specified time interval, to or from a zone generated by present or future land uses in that zone. The term normally refers to the non-home end of a trip. Trip attractions can also be defined as the non-home ends of home-based trips or the destinations of non-home-based trips. See also *trip productions*.

trip distance

linked (*total travel distance*)—the distance traveled on a linked trip, that is, the distance from the point of origin to the final destination, including the walking distance at trip ends and at transfer points.

unlinked—the distance traveled on an unlinked trip, for example, a trip on a single vehicle.

trip distribution—in planning, the process of estimating movement of trips between zones by using surveys or models; see also *urban transportation modeling system* and *model, sequential*.

trip end—a trip origin or a trip destination.

trip generation—in planning, the determination or prediction of the number of trips produced by and attracted to each zone; see also *urban transportation modeling system* and *model, sequential*.

trip generator—a land use from which trips are produced, such as a dwelling unit, a store, a factory, or an office.

trip length frequency distribution—a list or diagram of the number or the percentage of trips made at various intervals of trip time or distance.

trip matrix—in planning, an array of the number of trips made between each zone pair; see also *trip table*.

tripper—1. In transit operations, a short piece of work that cannot be incorporated into a full day's run, usually scheduled during peak hours. 2. In transit operations, a short work schedule for operators, usually 1–3 hr long; for example, during peak periods. 3. On some transit properties, a short run that is less than 8 hr long. 4. On some transit properties, a transit service that operates on only a portion of a route, usually at peak hours.

unpairable—a tripper that cannot be paired with another piece of work to form a day's work because of timing and applicable work rules, for example, the maximum spread rule.

trip productions—in planning, the number of trips, daily or for a specified time interval, that are produced from and return to a given zone, generally the zone of residence. Trip productions can also be defined as the home end of home-based trips or the origin of non-home-based trips. See also *trip attractions*.

trip purpose—the primary reason for making a trip, for example, work, shopping, medical appointment, recreation.

trip sheet—see *sheet, trip*.

trip table—a table that presents the number of trips between zones, classified by mode, purpose, time period, type of vehicle, or other category; see also *trip matrix*.

trip time—see *time, linked trip*; and *time, unlinked trip*.

trolley—1. An apparatus, such as a grooved wheel or shoe, at the end of a pole, used for collecting electric current from an overhead wire and transmitting it to a motor of a streetcar, trolleybus, or similar vehicle, where it is used for traction and other purposes. 2. Sometimes used locally as another term for a streetcar.

trolleybus (*electric trolleybus, trolley coach*)—an electrically propelled bus that obtains power via two trolley poles from a dual (positive and negative) overhead wire system along routes. It may be able to travel a limited distance on battery power or an auxiliary internal combustion engine. The power-collecting apparatus is designed to allow the bus to maneuver in mixed traffic over several lanes.

articulated—see *articulated bus* or *articulated trolleybus*.

trolley car—see *car, trolley*.

trolley coach—see *trolleybus*.

trolley pole—a swiveling spring-loaded pole attached on the roof of an electric bus or car that holds a wheel or sliding

shoe in contact with the overhead conductor (which usually takes the form of a thick wire), collects current from it, and transmits the current to the motor on the vehicle, for example, a streetcar or trolleybus.

trolley shoe—see *overhead contact shoe*.

trolley system—see *transit system, streetcar*.

trolley wire—see *contact wire*.

truck (*bogie*, British usage)—in rail transportation, a rail vehicle component that consists of a frame, normally two axles, brakes, suspension, and other parts, which supports the vehicle body and can swivel under it on curves. A truck usually also contains traction motors.

truck hunting—in rail operations, lateral instability of a truck, generally occurring at high speed and characterized by the shifting of one or both wheel sets from side to side so that the flanges strike the rail. The resulting motion of the rail car causes excessive wear in car and truck components and creates potentially unsafe operating conditions.

Trust Fund, Highway—see *Highway Trust Fund*.

tube transportation system—see *transportation system, tube*.

tunnel—1. An enclosed passageway, as for trains, automobiles, and so on, through or under an obstruction, such as a city, mountain, river, or harbor. 2. An underground passage.

turbine engine—see *engine, turbine*.

turboelectric car—see *car, dual-powered turboelectric*.

turn—see *shift*.

short—see *turn back*.

turnaround time—see *time, layover*.

turn back—1. In transit operations, to cut short a transit trip (to turn back before reaching the end of the route or line), usually to get back on schedule or to meet peak passenger demands; also known as a *short turn*. 2. In rail operations, a point along a track at which a train may reverse direction.

turn-in time—see *time, turn-in*.

turnout—1. In rail transportation, the assembly of a switch and a frog with closure rails by which rolling stock or trains can travel from a track onto either one of two diverging tracks; also known as a *track switch*. 2. A short side track or passage that enables trains, automobiles, and similar vehicles to pass one another. 3. A short passing lane on a highway.

bus—see *bus bay*.

turnover

labor—see *labor turnover*.

parking—see *parking turnover*.

turnover point—a point along a transit route at which a large proportion of passengers leave and board a transit unit.

turnstile, fare-registering—see *fare-registering turnstile*.

U

UA—urbanized area; see *area, urbanized*.

UBOA—United Bus Owners of America; see *organizations, United Bus Owners of America*.

UITP—see *organizations, International Union of Public Transport*.

UMTA—Urban Mass Transportation Administration; see *U.S. Government, Urban Mass Transportation Administration*.

UMTRIS—Urban Mass Transportation Research Information Service.

UPWP—unified planning work program.

USCM—United States Conference of Mayors; see *organizations, United States Conference of Mayors*.

U.S. DOT—U.S. Department of Transportation; see *U.S. Government, Department of Transportation*.

UTMS—urban transportation modeling system.

UTPS—Urban Transportation Planning System.

UTU—United Transportation Union; see *union, transit*.

UZA—used by some to indicate an urbanized area, although the Bureau of the Census uses UA; see *area, urbanized*.

underground—see *transit system, rail rapid*.

unidirectional car—see *car, unidirectional*.

unified planning work program (UPWP)—a document produced every year to describe all transportation-related planning activities that will be carried out during the next year. It includes planning to be done by all agencies in the region and details which agencies will be involved in each portion of the work program.

Uniform Financial Accounting and Reporting Elements—see *Financial Accounting and Reporting Elements*.

union (labor union, trade union)—an organization of wage earners or salaried employees for mutual aid and protection and for dealing collectively with employers in advancing the members' economic interests and general working conditions.

transit—one of the many unions representing various segments of the transit industry's work force. Three major ones are the *Amalgamated Transit Union (ATU)*, the *Transport Workers Union (TWU)*, and the *United Transportation Union (UTU)*. Their membership is limited to operators, mechanics, and other nonsupervisory employees.

unit

analysis—see *area, analysis*.

basic operating—see *basic operating unit*.

dwelling—see *dwelling unit*.

slave—see *engine, radio-controlled*.

transit—see *transit unit*.

United Bus Owners of America—see *organizations, United Bus Owners of America*.

United States Conference of Mayors—see *organizations, United States Conference of Mayors*.

United States Government—see *U.S. Government*.

United Transportation Union—see *union, transit*.

universe—see *population*.

unlimited access—see *access, unlimited*.

unlinked trip—see *trip, unlinked*.

unlinked trip distance—see *trip distance, unlinked*.

unlinked trip time—see *time, unlinked trip*.

unpairable tripper—see *tripper, unpairable*.

urban fringe—that part of an urbanized area outside the central city or cities.

Urban Mass Transportation Act—see *legislation, Urban Mass Transportation Act of 1964*.

Urban Mass Transportation Administration—see *U.S. Government, Urban Mass Transportation Administration*.

Urban Mass Transportation Research Information Service (UMTRIS)—a computer-based information storage and retrieval system developed by the Transportation Research Board under contract to the Urban Mass Transportation Administration. It consists of summaries of research projects in progress and abstracts of published works.

urban public transportation—transportation systems for intraurban or intraregional travel, available for use by any person who pays the established fare. It consists of transit and paratransit.

urban rail car—see *car, urban rail*.

urban transit bus—see *bus, standard urban*.

urban transportation modeling system (UTMS, four-stage model, four-step planning process)—a system of models used in transportation planning as an approach to urban travel demand modeling. It consists of four major stages: trip generation, trip distribution, modal split, and trip assignment. UTMS predicts the number of trips by type, time of day, zonal origin and destination, mode, and routes.

urban transportation planning process—the federally required planning process for urbanized areas that is aimed at developing programs to meet a region's transportation needs by analyzing the existing system and preparing plans and studies in a comprehensive, continuing, and cooperative manner. It results in several documents: a transportation systems management element (TSME), a transportation improvement program (TIP), a prospectus, a unified planning work program (UPWP), and a long-range element (LRE). See also *planning process*.

Urban Transportation Planning System (UTPS)—a tool for multimodal transportation planning developed by the Urban Mass Transportation Administration and the Federal Highway Administration. It is used for both long- and short-range planning, particularly system analysis, and covers both computerized and manual planning methods. UTPS consists of computer programs, attendant documentation, user guides, and manuals that cover one or more of five analytical categories: highway network analysis, transit network analysis, demand estimation, data capture and manipulation, and sketch planning.

urban transportation system—see *transportation system, urban*.

urbanized area—see *area, urbanized*.

U.S. Department of Transportation—see *U.S. Government, Department of Transportation*.

use, land—see *land use*.

useful life—the total productive time span of a piece of equipment, usually used with reference to vehicles.

user information (service information)—information on fares, stopping places, schedules, and other aspects of service essential to the efficient use of public transit. The term also refers to devices employed to convey such information, including bus stop signs, timetable brochures or books, telephone inquiries, and computerized user-interactive systems.

user-side or user subsidy—see *subsidy, user-side*.

U.S. Government

Amtrak—see *U.S. Government, National Railroad Passenger Corporation*.

Congressional Budget Office (CBO)—a federal office created by Congress to provide Congress with basic budget data and with analyses of alternative fiscal, budgetary, and programmatic policy issues.

Department of Energy (DOE)—a cabinet-level federal agency whose responsibilities include improving the energy efficiency of transportation.

Department of Health, Education, and Welfare (HEW)—a cabinet-level federal agency that provides funds for many specialized transportation services in urbanized and rural areas as part of its social service programs.

Department of Housing and Urban Development (HUD)—a cabinet-level federal agency whose responsibilities include community development programs, such as improved community facilities and services, assistance to nonprofit entities, and acquisition and rehabilitation of publicly owned real property.

Department of Labor (DOL)—a cabinet-level federal agency whose responsibilities include waivers of the labor protection provisions of Section 13(c) of the Urban Mass Transportation Act of 1964, as amended.

Department of Transportation (DOT)—a cabinet-level federal agency responsible for the planning, safety, and system and technology development of national transportation, including highways, mass transit, aircraft, and ports.

Environmental Protection Agency (EPA)—an independent federal agency in the executive branch whose responsibilities include development and enforcement of national air quality emission standards and support of antipollution activities by state and local governments.

Federal Communications Commission (FCC)—a U.S. agency whose responsibilities include licensing and regulation of radio communications, including those used in transportation facilities and vehicles.

Federal Highway Administration (FHWA)—a component of the U.S. Department of Transportation, established to ensure development of an effective national road and highway transportation system. It assists states in constructing highways and roads and provides financial aid at the local level, including joint administration with

U.S. Government (*continued*)

the Urban Mass Transportation Administration of the Section 18 program.

Federal Railroad Administration (FRA)—an agency of the United States government, established in 1966 as part of the U.S. Department of Transportation. It coordinates government activities that are related to the railroad industry.

Intermodal Planning Group (IPG)—a regional organization of federal agencies, set up to oversee transportation planning activities in the states of that region. It may include representatives of the Federal Highway Administration, Coast Guard, Federal Aviation Administration, Federal Railroad Administration, Urban Mass Transportation Administration, Department of Housing and Urban Development, Environmental Protection Agency, and other federal agencies.

Interstate Commerce Commission (ICC)—an administrative agency created by Congress to carry out economic regulation (entry, rates, services) of interstate commerce. Its members are appointed by the President.

National Railroad Passenger Corporation (Amtrak)—an agency created by Congress in 1970 to operate the national railroad passenger system. It also operates commuter rail service under contract, usually to metropolitan transit agencies.

National Transportation Safety Board (NTSB)—an independent agency of the federal government whose responsibilities include investigating transportation accidents and conducting studies, and making recommendations on transportation safety measures and practices to government agencies, the transportation industry, and others.

Office of Management and Budget (OMB)—a federal office in the Executive Office of the President, charged with the major task of preparing the preliminary budget for recommendation to Congress. It also controls allocation of funds from the Department of the Treasury to agencies.

Office of Technology Assessment (OTA)—a federal office created to serve Congress by providing objective analyses of major public policy issues related to scientific and technological change.

Urban Mass Transportation Administration (UMTA)—a component of the U.S. Department of Transportation, delegated by the Secretary of Transportation to administer the federal transit program under the Urban Mass Transportation Act of 1964, as amended, and various other statutes.

utilization coefficient—see *load factor*.



VKT—vehicle kilometers of travel; see *vehicle miles of travel*.

VMT—vehicle miles of travel.

vacation—see *abandonment*.

vacuum brake—see *brake, vacuum*.

validation—the marking of a ticket, pass, or transfer for the purpose of verifying its legitimate use for paid travel, usually giving time and place of marking.

value, default—see *default value*.

value engineering (value analysis)—an analysis of materials, processes, and products in which functions are related to cost and from which a selection may be made for the purpose of achieving the required function at the lowest overall cost consistent with the requirements for performance and maintainability.

van, subscription—see *service, subscription van*.

vanpool—an organized ridesharing arrangement in which a number of people travel together on a regular basis in a van. The van may be company owned, individually owned, leased, or owned by a third party. Expenses are shared, and there is usually a regular volunteer driver. See also *carpool*.

variable—a quantity that may have different values; a data measure used for analysis.

dependent—a variable whose value is determined for a given value of another variable.

independent—a variable whose value may be taken at will to be any value. Sometimes there are certain restrictions but its value is not dependent on another variable.

variable cost—see *cost, variable*.

vault—the part of the farebox that holds the money.

vehicle—any device or contrivance for carrying or conveying people or objects, including land conveyances, vessels, aircraft, and spacecraft. The term is sometimes specifically restricted to land conveyances on wheels, runners, treads, and so on.

air cushion (ACV, ground effect machine)—any vehicle supported by a cushion of air.

articulated rail—see *articulated rail vehicle*.

dual-mode—a vehicle that operates both manually on public streets and automatically on an automated guideway.

high-occupancy (HOV)—any passenger vehicle that meets or exceeds a certain predetermined minimum number of passengers, for example, more than two or three people per automobile. Buses, carpools, and vanpools are HOV vehicles.

light rail—see *car, light rail*.

passenger—a vehicle for transporting passengers.

prototype—a vehicle that is built to test a new design and that is expected to perform in essentially the same way that the production vehicle is meant to perform. When tested and perfected, the prototype becomes the model for production of series vehicles. See also *prototype system*.

public service—a vehicle used for public passenger transport.

revenue—a vehicle used to provide passenger transit service for which remuneration is normally required. It is

vehicle (*continued*)

distinct from nonrevenue equipment, which is used to build or maintain facilities, provide supervision, and so on.

tracked air cushion (TACV)—a laterally guided vehicle that is suspended above the track by an air cushion system.

tracked levitated (TLV)—a laterally guided vehicle that is suspended above the track by magnetic levitation.

vehicle capacity—see *capacity, vehicle*.

vehicle construction—see *body-on-chassis and integral structure*.

vehicle hour—the operation of a vehicle for a period of 1 hr.

vehicle layover—see *time, layover*.

vehicle location system—see *automatic vehicle location system*.

vehicle mile (vehicle kilometer)—the movement of one vehicle over a distance of 1 mile (kilometer).

vehicle miles, revenue—see *revenue vehicle miles*.

vehicle miles of travel (VMT; vehicle kilometers of travel, VKT)—1. On highways, a measurement of the total miles (kilometers) traveled by all vehicles in the area for a specified time period. It is calculated by the number of vehicles times the miles (kilometers) traveled in a given area or on a given highway during the time period. 2. In transit, the number of vehicle miles (kilometers) operated on a given route or line or network during a specified time period.

vehicle monitoring system—see *automatic vehicle monitoring system*.

vehicle occupancy—the number of people aboard a vehicle at a given time; also known as *auto or automobile occupancy* when the reference is to automobile travel only.

vehicle signal-actuating device—a device to control traffic signals that is activated by vehicles.

vehicle trip—see *trip, vehicle*.

velocity (speed)—the distance passed per unit of time, or the rate of change in location relative to time. For transportation vehicles, it is usually measured in miles (kilometers) per hour.

cruise (cruise speed)—the forward velocity that a vehicle maintains when it is neither accelerating nor decelerating. It is usually less than maximum design speed but can be equal to it.

effective (average speed)—the average velocity at which a vehicle travels. For transit vehicles, it includes dwell times at stops or stations, acceleration, and deceleration.

maximum theoretical—the highest theoretical velocity that a vehicle is physically capable of achieving.

vestibule—in rail systems, an enclosed space at each end of a passenger car.

vine—in planning, a record that shows the shortest routes from a given zone to all nodes; a node may be traversed more than once.

voltage

high—in rail transportation, the prime propulsion power voltage supplied by an overhead wire or third rail, usually 500–1,500 V direct current.

voltage (*continued*)

low—in rail transportation, the voltage used for most auxiliary systems (e.g., illumination, fans, public address systems), usually 24 or 72 V direct current or 110–240 V alternating current.

volume—in transportation, the number of units (passengers or vehicles) that pass a point on a transportation facility during a specified interval of time, usually 1 hr; see also *flow rate*.

design hourly—see *design hourly volume*.

line—see *passenger volume*.

link—see *link volume*.

passenger—see *passenger volume*.

service—see *service volume*.

W

WBE—women's business enterprise.

wage plan, guaranteed annual—see *guaranteed annual wage plan*.

wait time—see *time, wait*.

walkway, moving—see *moving walkway*.

way

bicycle—see *bicycle route*.

public—see *public way*.

wayside control system—see *control system, wayside*.

wayside lift—see *wheelchair lift*.

wayside signal—see *signal, wayside*.

weighted time—see *time, weighted*.

welded rail—see *rail, welded*.

wheel, flat—see *flat wheel*.

wheelchair lift—a device used to raise and lower a platform that facilitates transit vehicle accessibility for wheelchair users and other handicapped individuals. Wheelchair lifts may be attached to or built into a transit vehicle or may be located on the station platform (*wayside lifts*).

wheel flange—in rail systems, a projecting edge or rim on the circumference of a steel wheel that is designed to keep the wheel on a rail.

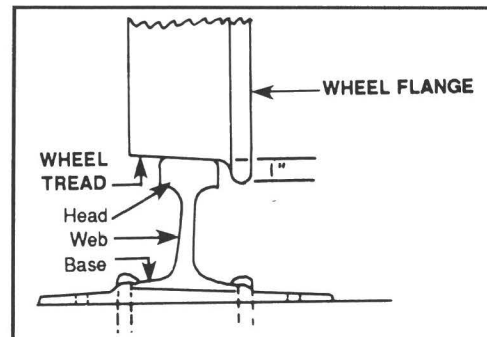

wheel tread—in rail systems, the exterior cylindrical or conical surface of a steel wheel that comes in contact with the rail.

wheels, driving—see *driving wheels*.

wide gauge—see *gauge, broad*.

wire, contact or trolley—see *contact wire*.

women's business enterprise (WBE)—a business owned and controlled by one or more women. WBEs require certification by the appropriate agency to receive preferential treatment for state or federal projects. See also *disadvantaged business enterprise*.

work

division of—see *work sharing*.

piece of—see *piece of work*.

share or spread the—see *work sharing*.

work hours—a fixed number of hours that are required to be worked each day.

flexible (flextime)—a work schedule in which employees can schedule the required number of work hours as they wish. It differs from staggered work hours in that it is the employee, not the employer, who sets the starting and ending times.

staggered—a work schedule in which employees' starting and ending times are staggered by the employer.

unified planning—see *unified planning work program*.

work run—see *run, work*.

work sharing (division of work, share the work, spread the work)—an arrangement designed to avoid layoffs, whereby available work during slack periods is spread as evenly or as equitably as possible among the regular employees by reducing each worker's daily or weekly hours or by establishing a week-on, week-off work schedule.

work time—see *time, platform*.

Y

yard—1. In rail systems, a facility within defined limits that has a system of tracks used for making up trains, storing rail cars, and other purposes. 2. In transit systems, an open storage lot for light rail vehicles, streetcars, electric trolley buses, and motor buses.

yard limits—a slow-speed area on main railroad tracks that often extends 5–10 mi (8–16 km) from either end of a yard. For transit operations, this distance is much shorter: it is usually confined to the yard itself or to a short lead, usually less than 1 mi (1.6 km) in length.

yaw—an angular motion about the vertical axis of a vehicle.

year

base—see *base year*.

forecast—see *forecast year*.

Z

zone

auto-free—see *auto-free zone*.

auto-restricted—see *auto-restricted zone*.

layover—see *layover zone*.

traffic assignment—see *traffic assignment zone*.

zone accessibility—see *accessibility, zone*.

zone or zoned fare—see *fare, zone*.

zoning—the division of an area into districts, and the public regulation of the character and intensity of use of the land and improvements thereon.

NOTES

NOTES

The **Transportation Research Board** is a unit of the National Research Council, which serves the National Academy of Sciences and the National Academy of Engineering. The Board's purpose is to stimulate research concerning the nature and performance of transportation systems, to disseminate the information produced by the research, and to encourage the application of appropriate research findings. The Board's program is carried out by more than 300 committees, task forces, and panels composed of more than 3,500 administrators, engineers, social scientists, attorneys, educators, and others concerned with transportation; they serve without compensation. The program is supported by state transportation and highway departments, the modal administrations of the U.S. Department of Transportation, and other organizations and individuals interested in the development of transportation.

The National Academy of Sciences is a private, nonprofit, self-perpetuating society of distinguished scholars engaged in scientific and engineering research, dedicated to the furtherance of science and technology and to their use for the general welfare. Upon the authority of the charter granted to it by the Congress in 1863, the Academy has a mandate that requires it to advise the federal government on scientific and technical matters. Dr. Frank Press is president of the National Academy of Sciences.

The National Academy of Engineering was established in 1964, under the charter of the National Academy of Sciences, as a parallel organization of outstanding engineers. It is autonomous in its administration and in the selection of its members, sharing with the National Academy of Sciences the responsibility for advising the federal government. The National Academy of Engineering also sponsors engineering programs aimed at meeting national needs, encourages education and research, and recognizes the superior achievements of engineers. Dr. Robert M. White is president of the National Academy of Engineering.

The Institute of Medicine was established in 1970 by the National Academy of Sciences to secure the services of eminent members of appropriate professions in the examination of policy matters pertaining to the health of the public. The Institute acts under the responsibility given to the National Academy of Sciences by its congressional charter to be an adviser to the federal government and, upon its own initiative, to identify issues of medical care, research, and education. Dr. Samuel O. Thier is president of the Institute of Medicine.

The National Research Council was organized by the National Academy of Sciences in 1916 to associate the broad community of science and technology with the Academy's purposes of furthering knowledge and advising the federal government. Functioning in accordance with general policies determined by the Academy, the Council has become the principal operating agency of both the National Academy of Sciences and the National Academy of Engineering in providing services to the government, the public, and the scientific and engineering communities. The Council is administered jointly by both the Academies and the Institute of Medicine. Dr. Frank Press and Dr. Robert M. White are chairman and vice chairman, respectively, of the National Research Council.

Transportation Research Board
National Research Council
2101 Constitution Avenue, N.W.
Washington, D.C. 20418

NON-PROFIT ORG.
U.S. POSTAGE
PAID
WASHINGTON, D.C.
PERMIT NO. 8970

ADDRESS CORRECTION REQUESTED

ISBN 0-309-04718-8

