



U.S. Department  
of Transportation

**Federal Highway  
Administration**

Publication No. FHWA-TS-89-034  
July 1989

---

# **Work Zone Traffic Management Synthesis:**

## **Selection And Application Of Flashing Arrow Panels**

---

Research, Development, and Technology  
Turner-Fairbank Highway Research Center  
6300 Georgetown Pike  
McLean, Virginia 22101-2296

FE  
28  
N636  
1989x

TE  
228  
.N636  
1989x

17567

FEB 28 '91

#### NOTICE

This document is disseminated under the sponsorship of the Department of Transportation in the interest of information exchange. The United States Government assumes no liability for its contents or use thereof.

The contents of this report reflect the views of the contractors who are responsible for the facts and the accuracy of the data presented herein. The contents do not necessarily reflect the official views or policy of the Department of Transportation.

This report does not constitute a standard specification, or regulation.

The United States Government does not endorse products or manufacturers. Trademarks or manufacturers' names appear herein only because they are considered essential to the object of this document.



1. Report No. FHWA-TS-89-034		2. Government Accession No.		3. Recipient's Catalog No.	
4. Title and Subtitle Work Zone Traffic Management Synthesis: Selection and Application of Flashing Arrow Panels				5. Report Date July 1989	
				6. Performing Organization Code	
7. Author(s) Errol C. Noel, Ziad A. Sabra, Conrad L. Dudek				8. Performing Organization Report No.	
9. Performing Organization Name and Address  Contractor: Daniel Consultants, Inc. Columbia, Maryland Subcontractor: Dudek & Assoc., Bryan, Texas				10. Work Unit No. (TR AIS) NCP 3A9a 0073	
				11. Contract or Grant No. DTFH61-88-X-0007	
12. Sponsoring Agency Name and Address Federal Highway Administration Turner-Fairbank Highway Research Center 6300 Georgetwon Pike McLean, Virginia 22101-2296				13. Type of Report and Period Covered  Final Report May 1988 - May 1989	
				14. Sponsoring Agency Code	
15. Supplementary Notes  FHWA Contract Manager: Guenther Lerch, HRT-20					
16. Abstract  This report is a synthesis of research findings and current practices in the selection and application of arrow panels in work zones. The information presented here is based on a review of research reports and work zone manuals of a selection of state and city highway agencies, discussions with high way officials, and field observation of a selection of highway construction projects. The report presents an assessment of the state-of-the-practice and makes recommendations for further research and specification inclusions in the future revisions of the <u>Manual on Uniform Traffic Control Devices</u> .					
17. Key Words  flashing arrow panels, mini-panels work zones, arrow boards			18. Distribution Statement  No restrictions. This document is available to the public through the National Technical Information Service, Springfield, VA 22161		
19. Security Classif. (of this report)  Unclassified		20. Security Classif. (of this page)  Unclassified		21. No. of Pages  74	22. Price

# SI\* (MODERN METRIC) CONVERSION FACTORS

## APPROXIMATE CONVERSIONS TO SI UNITS

Symbol	When You Know	Multiply By	To Find	Symbol
--------	---------------	-------------	---------	--------

### LENGTH

in	inches	25.4	millimetres	mm
ft	feet	0.305	metres	m
yd	yards	0.914	metres	m
mi	miles	1.61	kilometres	km

### AREA

in <sup>2</sup>	square inches	645.2	millimetres squared	mm <sup>2</sup>
ft <sup>2</sup>	square feet	0.093	metres squared	m <sup>2</sup>
yd <sup>2</sup>	square yards	0.836	metres squared	m <sup>2</sup>
ac	acres	0.405	hectares	ha
mi <sup>2</sup>	square miles	2.59	kilometres squared	km <sup>2</sup>

### VOLUME

fl oz	fluid ounces	29.57	millilitres	mL
gal	gallons	3.785	litres	L
ft <sup>3</sup>	cubic feet	0.028	metres cubed	m <sup>3</sup>
yd <sup>3</sup>	cubic yards	0.765	metres cubed	m <sup>3</sup>

NOTE: Volumes greater than 1000 L shall be shown in m<sup>3</sup>.

### MASS

oz	ounces	28.35	grams	g
lb	pounds	0.454	kilograms	kg
T	short tons (2000 lb)	0.907	megagrams	Mg

### TEMPERATURE (exact)

°F	Fahrenheit temperature	$5(F-32)/9$	Celcius temperature	°C
----	------------------------	-------------	---------------------	----

## APPROXIMATE CONVERSIONS FROM SI UNITS

Symbol	When You Know	Multiply By	To Find	Symbol
--------	---------------	-------------	---------	--------

### LENGTH

mm	millimetres	0.039	inches	in
m	metres	3.28	feet	ft
m	metres	1.09	yards	yd
km	kilometres	0.621	miles	mi

### AREA

mm <sup>2</sup>	millimetres squared	0.0016	square inches	in <sup>2</sup>
m <sup>2</sup>	metres squared	10.764	square feet	ft <sup>2</sup>
ha	hectares	2.47	acres	ac
km <sup>2</sup>	kilometres squared	0.386	square miles	mi <sup>2</sup>

### VOLUME

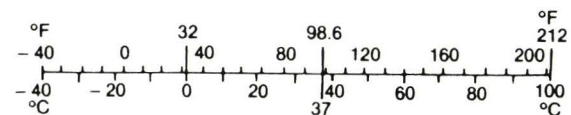
mL	millilitres	0.034	fluid ounces	fl oz
L	litres	0.264	gallons	gal
m <sup>3</sup>	metres cubed	35.315	cubic feet	ft <sup>3</sup>
m <sup>3</sup>	metres cubed	1.308	cubic yards	yd <sup>3</sup>

### MASS

g	grams	0.035	ounces	oz
kg	kilograms	2.205	pounds	lb
Mg	megagrams	1.102	short tons (2000 lb)	T

### TEMPERATURE (exact)

°C	Celcius temperature	$1.8C + 32$	Fahrenheit temperature	°F
----	---------------------	-------------	------------------------	----



\* SI is the symbol for the International System of Measurement



## TABLE OF CONTENTS

	Page
LIST OF FIGURES .....	iv
LIST OF TABLES .....	v
I. INTRODUCTION .....	1
A. Driver Needs.....	1
B. Driver Understanding of Arrow Panels .....	2
C. Placement of Arrow Panels for Lane Closures ...	6
D. Effectiveness of Arrow Panels in Lane Closures .....	7
II. DESIGN REQUIREMENTS AND SPECIFICATIONS .....	11
A. Manual on Uniform Traffic Control Devices (MUTCD) .....	11
B. State and Local Specifications .....	11
1. Panels .....	11
2. Lamps .....	12
3. Mounts .....	12
4. Operation Controls .....	12
5. Power Supply .....	17
C. Design Specifications of Non-Standard Arrow Panels .....	17
D. Crashworthiness of Arrow Panels .....	20
III. APPLICATIONS IN PRACTICE .....	23
A. MUTCD Requirements .....	23
B. Current Use of Standard Arrow Panels .....	25
1. Left and Right Lane Closures .....	25
2. Center Lane Closures .....	29
3. Multi-Lane Closures .....	33
4. Moving Maintenance Lane Closure Operations .....	36
5. Shoulder Closure .....	36
6. Lane Diversions .....	41
7. Traffic Splits .....	47
C. Summary of Current Practices .....	47
D. Current Use of Non-Standard Arrow Panels .....	49
1. State Governments .....	49
2. Municipalities .....	51
3. Utility Companies .....	54
IV. MAINTENANCE AND COST OF ARROW PANELS .....	56
A. Maintenance .....	56
B. Cost of Equipment .....	57
V. CONCLUSIONS .....	59
VI. RECOMMENDATIONS .....	62
A. Arrow Panel Applications .....	62
B. Arrow Panel Specifications .....	64
C. Further Research on Arrow Panels .....	65

	Page
LIST OF REFERENCES .....	67

**LIST OF FIGURES**

Figure 1.	Designation of information handling zones related to positive guidance procedure .....	3
Figure 2.	Arrow panel modes.....	4
Figure 3.	Lamp spacing details for the arrow panel ...	14
Figure 4.	Lamp spacing details .....	15
Figure 5.	Configuration of standard and non-standard arrow panels .....	21
Figure 6.	Application of the arrow panel in typical right lane closures .....	26
Figure 7.	Application of the arrow panel in left lane closures .....	27
Figure 8.	Placement of the arrow panel for typical right lane closures in Michigan and Pennsylvania .....	28
Figure 9.	Application of the arrow panel in lane closures on local streets .....	30
Figure 10.	Arrow panel applications in multi-lane closures .....	31
Figure 11.	Arrow panel applications in center lane closures on urban and rural roadways .....	32
Figure 12.	Proposed TCDH revision for use of one arrow panel in center lane closure .....	34
Figure 13.	Application of arrow panels in multi-lane closures .....	35
Figure 14.	Moving-maintenance lane closure on urban arterials .....	37
Figure 15.	Application of the arrow panel in rural moving operations on four and six-lane divided highways .....	38
Figure 16.	Application of the arrow panel in moving operations for single and multi-lane closures .....	39
Figure 17.	Application of the arrow panel for moving operations .....	40
Figure 18.	Application of the caution bar mode for shoulder closure .....	42
Figure 19.	Traffic control for shoulder closure .....	43
Figure 20.	Application of the arrow panel in crossovers .....	44
Figure 21.	Application of the arrow panel in crossovers with lane reductions .....	45
Figure 22.	Lane shift without lane closure and arrow panel .....	46
Figure 23.	Application of the arrow panel in typical traffic split .....	48



	Page
Figure 24. Non-standard arrow panel on an interstate highway .....	50
Figure 25. Use of mini-arrow panels on local streets ..	52
Figure 26. Use of mini-arrow panels on local streets ..	53

#### LIST OF TABLES

Table 1. Summary of arrow panel specifications .....	12
Table 2. Non-standard arrow panel specifications .....	18
Table 3. Non-standard arrow panel specifications (Table 2 continued) .....	19
Table 4. Use of arrow panels in work zones .....	24
Table 5. Cost of arrow panels .....	58





## I. INTRODUCTION

Arrow panels are sign panels with a matrix of lights capable of displaying an illuminated flashing arrow or sequential arrow pattern or an illuminated flashing warning. Arrow panels provide advance warning to motorists when the travel lanes are closed or diverted or when work is being done on the shoulder. Arrow panels are often used in conjunction with other traffic control devices such as construction warning signs and channelization devices.

General guidelines for the design, application, and operation of standard arrow panels are presented in Sections 6E-7 through 6E-9 on the Manual on Uniform Traffic Control Devices (MUTCD) (1). Since their introduction to the MUTCD in 1977, standard arrow panels are widely used by state highway departments, municipalities, utility companies, and contractors. The arrow panel is primarily used for lane closures. Other applications of the arrow panel include lane diversion, traffic splits, shoulder closure, and lane closure during moving-maintenance activities.

This synthesis discusses current practices in the design and application of arrow panels based on a review of the literature and state standards, field observations, and discussions with state highway officials in California, Illinois, Maryland, Michigan, New York, Virginia, and Pennsylvania. Discussions were also held with local highway officials in San Francisco, Washington, D.C., Chicago, Detroit, New York City, Baltimore, Richmond, and Philadelphia.

**A. Driver Needs.** Despite the use of conventional highway work zone warning signs and channelizing devices for lane closures, drivers must still make several critical decisions quickly. Prior to changing lanes, drivers must detect, recognize, and comprehend visual cues and then decide on the appropriate response. These actions become increasingly demanding when the driver does not obtain all the necessary information, is overloaded with information, or the information is confusing. These are the areas where the potential for serious accidents is high. Proper selection and installation of traffic control devices can help guide the motorist on the approach to and through the work zone.

Positive guidance in work zones reduces the risk of accidents, provides longer advance warning sign detection, promotes earlier merging into an open lane, and facilitates driver passage through the visual clutter of construction and maintenance equipment, alignment shifts, work crews and traffic control devices. The driver's information and guidance needs

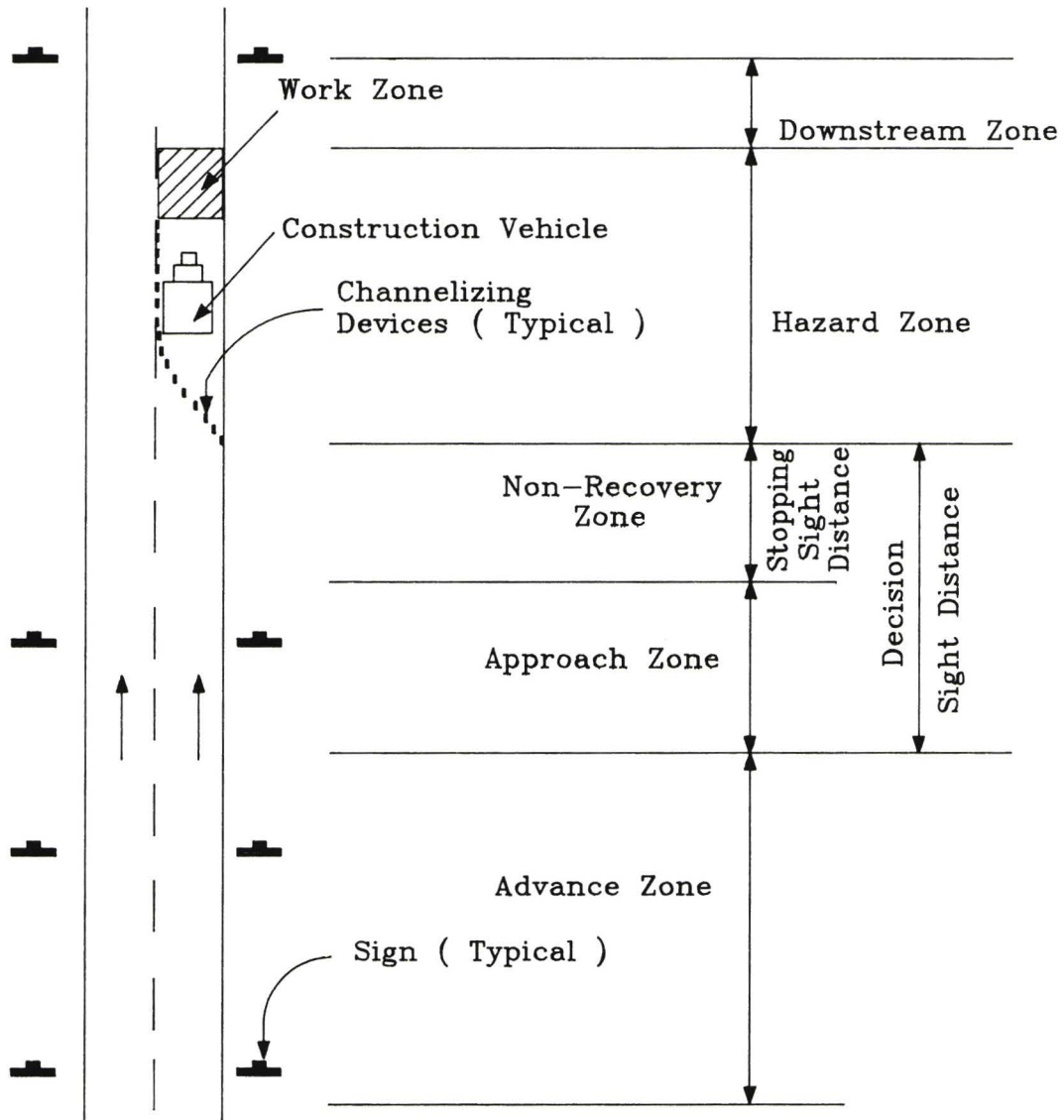
subareas as shown in Figure 1:

1. Advance Zone - where hazards or inefficiencies do not yet affect the driver's task.
2. Approach Zone - where the driver must detect and recognize the hazard ahead. This zone corresponds to the decision sight distance minus the stopping sight distance. The American Association of State Highway and Transportation Officials (AASHTO) (27) recognizes that stopping sight distances are often inadequate when drivers must make complex or instantaneous decisions, when information is difficult to perceive, or when unexpected or unusual maneuvers are required. In these circumstances, decision sight distance must provide the greater length that drivers need. Decision sight distance is the distance required for a driver to detect an unexpected or otherwise difficult-to-perceive information source or hazard in a roadway environment that may be visually cluttered, recognize the hazard or its threat potential, select an appropriate speed and path, and initiate and complete the required safety maneuver safely and efficiently. (27, 28)
3. Non-Recovery Zone - point beyond which there is insufficient space to avoid a system failure. A system failure can range from a non-catastrophic failure such as traffic delay to a catastrophic failure such as a fatal accident (28).
4. Hazard Zone - distance corresponding to the length of the hazard.
5. Downstream Zone - area beyond the hazard corresponding to the distance it takes to safely return to normal operating conditions.

Driver information requirements in each of the above subareas has been studied by Hostetter, et al. (32). The arrow panel specifically meets some of the needs of drivers by alerting them and guiding through the work zone. The arrow panel has been tested and its effectiveness has been well documented (4, 5, 6, 7).

**B. Driver Understanding of Arrow Panels.** The arrow display is of three types: 1) flashing arrow; 2) sequential arrow; and 3) sequential chevron. Each standard arrow panel is capable of displaying three or four basic operating modes such as left arrow, right arrow, double arrow and caution mode (four or more lamps arranged in a pattern which does not indicate a direction). The operating modes of arrow panel are shown in Figure 2.





Source: References ( 2 , 3 )

Figure 1. Designation of information handling zones related to positive guidance procedure

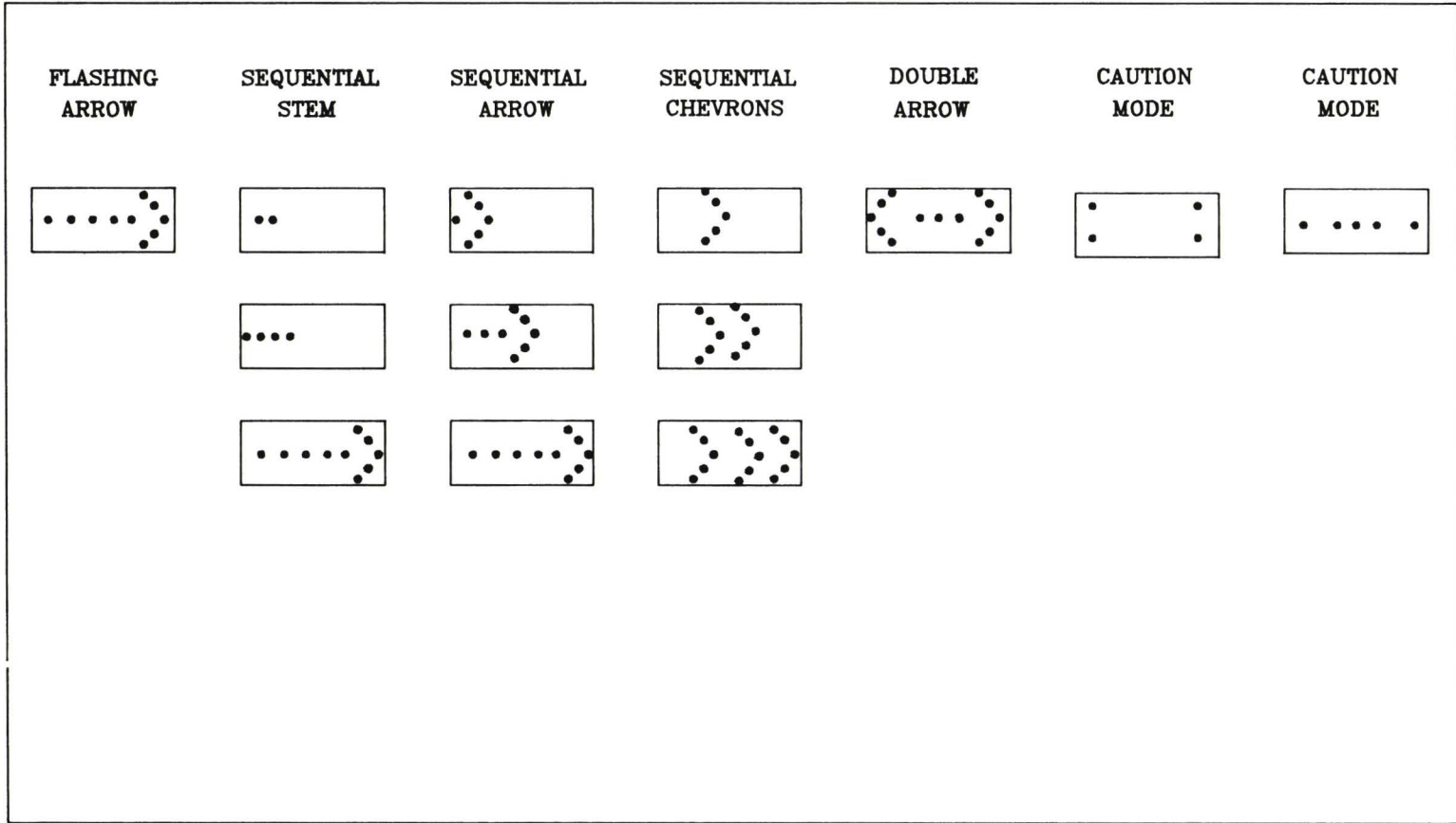


Figure 2. Arrow panel modes

As early as 1978 Graham et al. (7) found in laboratory studies using a sample of twenty subjects that the flashing arrow and sequential arrow were understood by a high percentage of drivers (95%) to mean that a lane was closed and the driver must change lanes ahead. Graham et al. acknowledged that the sample was not representative of the driving population. Driver preference studies were also conducted with employees of one company located in the midwest and with employees of the Federal Highway Administration in Washington, D.C. in an attempt to address the question of whether the three modes, i.e., flashing arrow, sequential arrow, and sequential chevrons, could be essentially interchangeable in directing the driver to shift from the closed lane, or whether one mode might be superior or more effective in conveying this meaning. However, certain trends emanated from the studies. First, the flashing arrow and the sequential chevron were clearly preferred over the sequential arrow. Secondly, almost an equal number of the 109 subject drivers preferred the flashing arrow and the sequential chevron, although the flashing arrow was definitely preferred over the sequential arrow by the subjects in Washington, D.C. The authors indicated that there may have been a regional bias based on the more common usage of the flashing arrow panel in the Washington, D.C. area.

Because drivers interpret the flashing arrow and sequential arrow to mean that a lane is closed ahead, they are not generally effective in diversions (detours, crossovers, or bypass roadways) (7). Field studies by Graham et al. (7) indicate that arrow panels do cause unnecessary lane changes in diversion work zones.

Results of studies conducted by Pain et al. (9) support the findings of the aforementioned studies. In their study, Pain et al. (9) concluded that the flashing arrow and sequential chevron displays distinctly mean lane closure. Pain et al. added that, in real world situations, the sequential chevron may have some pitfalls which are more serious than those of the flashing arrow. Although the sequential chevron provides a strong directional indication to the driver it uses three pulses to convey its message as opposed to two pulses for the flashing arrow. The authors (9) believe that the meaning of the three pulses of the sequential chevron has a greater tendency to be degraded if displayed at night or when diffused under inclement weather.

Although more research may be needed on the use of arrow panels in work zones, the meaning of arrow panel displays for left and right lane closures appears to be well understood by drivers. Drivers' understanding of the arrow panel display for shoulder work, diversions, and split situations, however, is not yet documented convincingly and should be researched further.



**C. Placement of Arrow Panels for Lane Closures.** According to Section 6E-8, Part VI, of the MUTCD (1), the placement of the arrow panel should vary as needed to achieve the desired recognition distances. For stationary lane closures, the arrow panel should be placed on the shoulder at the beginning of the taper. Where applicable for diversions, the MUTCD indicates that the arrow panel should be placed behind the barricades closing the roadway. Research addressing arrow panel placement has focused on several scenarios including placement of the arrow panel in the middle of the taper, at the beginning of the taper, and upstream of the taper at distances ranging from 100 to 2,000 feet.

Knapp and Pain (29) in 1978 recommended the placement of a flashing arrow panel at the beginning of the taper. Graham et al. (7) concluded from field studies conducted in the late 1970s that the best placement of an arrow panel is on the shoulder about 100 to 500 feet upstream of the taper. The authors further concluded that the arrow panel is optimally placed when it is on the shoulder head-on to the driver. Arrow panel effectiveness is reduced when the roadway curvature precludes a head-on viewing.

Faulkner and Dudek (6) evaluated the use of a supplemental arrow panel at work zones where sight distance to the work area is restricted (less than 1,500 feet). Studies were conducted using an arrow panel with a flashing arrow at the taper but also using a second (supplemental) arrow panel with a flashing arrow on the shoulder upstream of the taper in order to improve the effective sight distance to the work zone. The results indicate that for right-side or left-side lane closures a supplemental arrow panel placed on the shoulder upstream of the lane closure can be extremely effective in shifting traffic from the closed lane if the sight distance to the arrow panel improves the effective sight distance to the work zone. The supplemental arrow panel can be placed up to 2,500 feet upstream of the taper. Placement more than 2,500 feet in advance of the work zone may result in drivers moving back into the closed lane.

When a lane is closed for short-term mobile operations, the Traffic Control Devices Handbook (TCDH) (10) suggests the arrow panel be placed at the rear of the activity in the closed lane on a vehicle separate from the maintenance vehicle itself. Studies conducted by Bryden (11) and Dudek et al. (12) concurred with the TCDH.

The majority of research on arrow panel placement focused on freeway operation and single lane closures. Arrow panel placement for multi-lane closures on freeways and applications for local streets have been virtually ignored in the literature. While multi-arrow panels are now commonly used on multi-lane closures, there is no literature to support its use. Urban work areas present unique settings which need special



attention in order to promote the proper use of arrow panels.

**D. Effectiveness of Arrow Panels in Lane Closures.** The predominant finding among researchers is that arrow panels, when placed properly at the beginning of the construction taper, are very effective devices for lane closures because they promote an early and smooth merge into the open lane. The effectiveness of arrow panels has been demonstrated to be a function of parameters such as panel size, angularity and placement, operation mode, type of roadway facility, work zone activity, and traffic conditions. When examined, the effectiveness of the arrow panel has been measured in terms of reduced speed, queuing, conflicts, and trapped vehicles in the closed lane.

In 1974, McAllister and Kramer (8) of the California Department of Transportation (Caltrans) conducted field studies in an attempt to determine the most effective size and type of arrow panel for use in work zones. Thirteen arrow panel sizes, ranging in size from 24 inches x 48 inches to 48 inches x 96 inches were tested. The arrow panels were mounted eight feet high on trailers and placed on the median shoulder of a freeway and displayed a merge-right pattern. The study concluded that the 48-inch x 96-inch arrow panel was more effective than the smaller panels during the daytime. The flashing arrow was more effective than the sequencing arrow pattern during nighttime operation. Vehicle speeds were also reduced up to five miles per hour due to the arrow panels.

In 1974, Bates (13) of the Illinois Department of Transportation conducted a study to examine the effectiveness of a second arrow panel in work zones for earlier merging from two lanes onto one lane. The second arrow panel was placed one-half mile upstream of the lane merging point and the other arrow panel was placed just behind the barricades at the merging point. Both arrow panels were mounted on trucks. The arrow panel performance was measured in terms of a ratio of the percent of vehicles in the closed lane without arrow panels to percent of vehicles in the closed lane with arrow panels. The ratio was determined for three points: 4,700 feet before the merge; 2,100 feet before the merge; and at the point of merge. The ratio was consistently higher at the merge point for the right lane closure. Bates (13) concluded that a second upstream arrow panel is very effective in promoting an earlier traffic merge.

In 1976, Shah and Ray (14) of the Louisiana Department of Highways experimented with a 3.5-foot x 6.5-foot, trailer-mounted, sequencing chevron arrow panel. The arrow panel was tested as a supplement to standard work zone warning signs. The study concluded that the use of a sequential chevron arrow panel in addition to warning signs reduced speeds and queue lengths significantly. Queuing lengths were reduced by 72



percent when the sequencing chevron panel was used as opposed to 51 percent when the arrow panel was not used.

Studies conducted by Graham et al. (15) in 1977 indicated that vehicle speeds and erratic maneuvers were reduced due to the presence of arrow panels. In their studies of 79 projects in seven States, the sequential flashing arrow panel placed in the closed lane near the transition point reduced speeds by nearly three miles per hour, reducing erratic maneuvers by 25 percent but increasing the slow-moving vehicle conflict rate by 20 percent.

In 1978, Graham et al. (7) examined the effectiveness of several types of arrow panels for lane closures as well as for diversions (detours), splits, and shoulder closures. The term diversion (detour) is used in this context to mean a situation where all lanes remain open through the work zone, but the lanes deviate from the normal path.

Laboratory studies were conducted by Graham et al. (7) in 1978 to evaluate driver understanding of and preferences for the following arrow panel modes: (1) flashing arrow, (2) sequential stem, (3) sequential arrow, (4) sequential chevron, (5) double arrow, and (6) two caution modes (alternating side lights and flashing stem). The driver understanding studies using 20 employees of the research organization revealed that the arrows and chevrons connoted a lane closure ahead with a high confidence level for 95 percent of the subjects. The arrows and chevrons seemed to indicate a lane closure for 75 percent of the subjects, even though the arrow panel was placed on the shoulder. The flashing bar (caution mode) caused confusion. The researchers concluded that the role of the caution mode needed more in-depth examination, considering the confusion demonstrated by the 20 subjects.

The driver preference studies (7) of the flashing arrow, sequential arrow and sequential chevron for lane closures which used 63 employees of a company in the midwest and 49 employees of the Federal Highway Administration in Washington, D.C., indicated that the choice of arrow panel mode seemed to be related to driver experiences at work zones within geographic regions. The drivers at the midwest company clearly preferred the flashing arrow and the sequential chevrons over the sequential arrow. The flashing arrow and the sequential chevrons did not separate out significantly between themselves, indicating that these might be used interchangeably. The Federal Highway Administration employees also clearly preferred the flashing arrow and the sequential chevron over the sequential arrow. However, this sample also showed a clear preference for the flashing arrow over the sequential chevrons. The researchers indicated a regional bias toward the flashing arrow near the Washington, D.C. area because the Commonwealth of Virginia did not use the sequential chevrons at the time of the study.



Subsequent field studies were conducted by Graham et al. (7) at 20 work zone lane closure locations to evaluate the effectiveness of the following arrow panel modes: flashing arrow, sequential stem, sequential arrow, and sequential chevron. The studies revealed that the arrow panels are effective in encouraging drivers to leave the closed lane sooner, thus reducing the number of vehicles in that lane near the start of the taper. The researchers did not find any statistically significant differences in effectiveness among the arrow panel modes. However, the larger arrow panels (48 inches x 96 inches) were found to be more effective than the smaller panels, particularly during the peak periods and at night.

Arrow panels are also effective supplementary devices for slow-moving maintenance operations. Bryden (11) of the New York Department of Transportation measured the arrow panel effectiveness at six maintenance sites involving lane striping and pavement marking. Several arrow panel sizes were examined; all arrow panels operated in the sequential stem-arrow mode and were mounted on maintenance trucks. Bryden found that the 36-inch x 72-inch arrow panel increased detectability substantially. The approaching traffic vacated the occupied lane much sooner when a larger arrow panel was mounted on the rear maintenance vehicle. Speeds were reduced 6 to 10 miles per hour with the larger arrow panel. Lane changes began occurring when traffic was about 20 seconds -- 1800 feet at 60 miles per hour -- behind the last maintenance vehicle with or without a small panel mounted on it. With the large panel (36 inches x 72 inches), however, lane changes began as far back as 30 seconds -- 2700 feet at 60 miles per hour. The only significant improvement for the small panels was for vehicles changing lanes 7 seconds or less -- 600 feet behind the truck-mounted panel. Beyond that distance, the small panel (24 x 48 inches) had little increased target value over a standard protection scheme without an arrow panel.

Studies conducted by Dudek et al. (16) in 1979, involved the use of changeable message signs: (1) upstream of the warning signs and in conjunction with an arrow panel in the taper area for a work zone lane closure to encourage drivers to vacate the closed lane earlier and (2) upstream of a freeway-to-freeway interchange to encourage drivers to divert to an alternate freeway route to avoid congestion at a downstream work zone. The studies revealed that changeable message signs (CMSs) can be used at lane closure work zones to encourage more drivers to vacate the closed lane(s) farther upstream of the cone taper. The researchers state, however, that CMSs should not be used in place of flashing arrow panels at these work zones. The diversion studies also determined that CMSs can be used to divert traffic around freeway maintenance work zone to an alternate freeway route.

In 1989, Dudek and Ullman (30) conducted field studies to develop and evaluate reduced traffic control signing treatments for short duration maintenance operations involving lane closures on four-lane divided highways with average annual daily traffic less than or equal to 30,000 vehicles per day. For these short duration maintenance operations, the actual placement of the advanced warning signs and channelizing devices that are required by the MUTCD often takes longer than the actual work activity itself. The MUTCD considers the arrow panel to be a supplement to the advanced warning signs. Because of the demonstrated effectiveness of the arrow panel, Dudek and Ullman suggest that the arrow panel may be the primary traffic control device and the signs upstream may serve to supplement the arrow panel. Field studies were conducted to evaluate whether only one sign, either of four warning devices (CMS, Texas Lane Blocked sign, lane closed symbolic sign or Road Work Ahead sign), could be used instead of the normal series of three advance warning signs specified by the MUTCD. The field studies showed that, for the conditions studied, the use of the arrow panel at the taper in combination with either the CMS or the Texas Lane Blocked sign was more effective than the full series of signs required by the MUTCD.

In summary, the above studies indicate that the arrow panel, especially the flashing arrow and sequential chevron, is effective in promoting earlier merging into the open lane for stationary single and multi-lane closures and for moving-maintenance operations. The effectiveness of the arrow panel in diversions (lane shifting), splits, and shoulder closures, however, is still uncertain.



## II. DESIGN REQUIREMENTS AND SPECIFICATIONS

Arrow panels consists of five components: 1) panel; 2) lamps; 3) mounts; 4) operation controls; and 5) power supply. Standard arrow panels are those which satisfy the minimum requirements of Section 6E-9, Part VI, of the MUTCD. There has been a proliferation of non-standard arrow panels, however, which do not satisfy the viewing distance, display, dimensional characteristics, and rectangular flat black background panel requirements of the MUTCD. This section of the report contrasts the MUTCD with the traffic control manuals used in several states. In view of the easy availability of non-standard mini-arrow panels, some discussion on that subject is also presented.

**A. Manual on Uniform Traffic Control Devices (MUTCD).** Section 6E-9, Part VI, of the MUTCD provides design specifications for arrow panels. These specifications are summarized on Table 1. For example, the MUTCD requires the minimum lamp "on time" to be 50 percent for the flashing arrow and 25 percent for the sequential chevron. The arrow panel lamps are also required to be recess mounted or alternately equipped with an upper hood of not less than 180 degrees and the color of the emitted light is to be yellow. The MUTCD lacks specifications on lamp sizes, spacing, candle power, and power supply. Also, lacking are the applicable highway speed ranges in which each size of the arrow panels may be used.

### **B. State and Local Specifications.**

1. **Panels.** All the states and local jurisdictions reviewed have requirements and specifications for the minimum permissible size of arrow panels. The minimum acceptable sizes range from 24 x 48 to 48 x 96 inches. The 24 x 48-inch panels are used exclusively on low-speed roadways, while the larger panels (30 x 60 and 48 x 96-inch panels) are used on intermediate and high speed facilities, respectively. Unlike the MUTCD, states such as Minnesota, Delaware, and Ohio specify the low, intermediate, and high speed range for each of the arrow panel types. Ohio, for example, has defined its speed specifications as 20-35 miles per hour, 35-50 mile per hour, and 55 miles per hour for the low, intermediate, and high speed roadways, respectively.

Most of the states reviewed have specifications pertaining to the panel's exterior design and strength included either in their Manual on Uniform



Table 1. Summary of arrow panel specifications

Type	Min. Panel Size (inches)	Appl. Speed	Min. no. of lamps	Legib. Dist.	Panel	Mounts (Height)	Operation Control	Mode Select.
A	24 x 48	Low	12	1/2 mile	RNFB	min. 7'	25-40 FPM 50% dimming	L,R, LR,C
B	30 x 60	Inter- mediate	13	3/4 mile	RNFB	min. 7' T/V	25-40 FPM 50% dimming	L,R, LR,C
C	48 x 96	High	15	1 mile	RNFB	min. 7' T/V	25-40 FPM 50% dimming	L,R, LR,C

Source: (1, 10)

RNFB - denotes rectangular and finished non-reflective black

T/V - denotes trailer or vehicle mounted

FPM - flashers per minutes

L - left, R - right, LR - left and right, C - caution (four or more lamps arranged in a pattern which will not indicate a direction)

Traffic Control Devices or in other operating procedures. Ohio, for example, specifies that the flasher panel must be exterior-type plywood or corrosion resistant metal construction of adequate design and strength. All states indicate that the panel finish shall be flat rectangular black exclusively.

2. **Lamps.** The number and color of lamps are found in all state manuals. Lacking, however, is information on the lamp type, size, and spacing. Where specified, the lamp size varies between 4 and 5 inches for the 24 x 48 and 48 x 96-inch panels, respectively. Similarly, the spacing between lamps varies depending on the panel size. Figures 3 and 4 demonstrate lamp spacing details for various standard arrow panel sizes used in Ohio, Delaware, and Michigan. Spacing between lamps on the arrow stem is approximately 11 and 14.5 inches for the 30 x 60 and 48 x 96-inch panels, respectively.
3. **Mounts.** Detailed specifications for mounting and supporting devices for stationary and mobile operations are lacking in work zone traffic control standards of most states. Casual mention of trailer and vehicle mounting is usually made with very little attention given to transportability of the panel and lifting and leveling devices for stability during stationary operations. The mounting height of arrow panels varies and ranges from 6 feet for vehicle-mounted panels to 8 feet for trailer-mounted panels.
4. **Operation Controls.** The specifications on arrow panel control covers both flashing and dimming. Most states follow the MUTCD specifications which require the flashing rate per minute to be not less than 25 nor more than 40. Few states deviate from the MUTCD's requirement. Delaware requires a minimum flashing rate of 25 flashes per minute, with no upper limit.

All state specifications follow the MUTCD's requirement on arrow panel dimming, i.e., arrow panels shall be capable of a minimum of 50 percent dimming from their rated lamp voltage. Dimming control of arrow panels is normally provided either manually or automatically by means of light sensitive photocells. Most of the states visited, however, require the use of a photoelectric dimming control which varies the lamp intensity by means of a photoelectrically controlled circuit which reduces lamp output during low ambient light conditions. Normally, the photoelectric control unit is calibrated to actuate a lamp dimming circuit at two

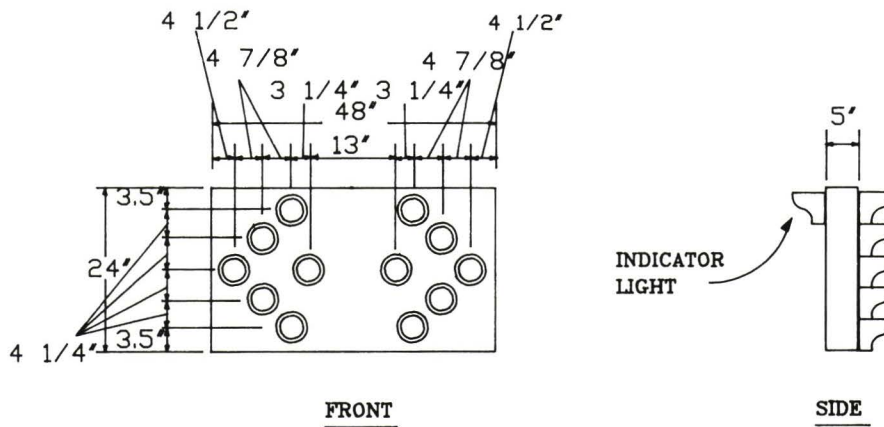
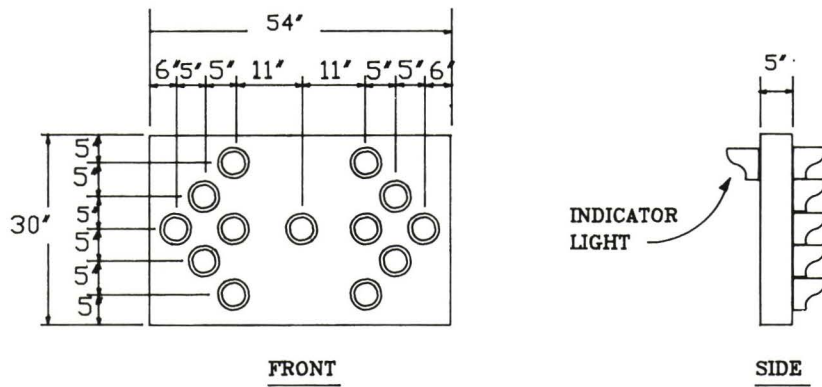
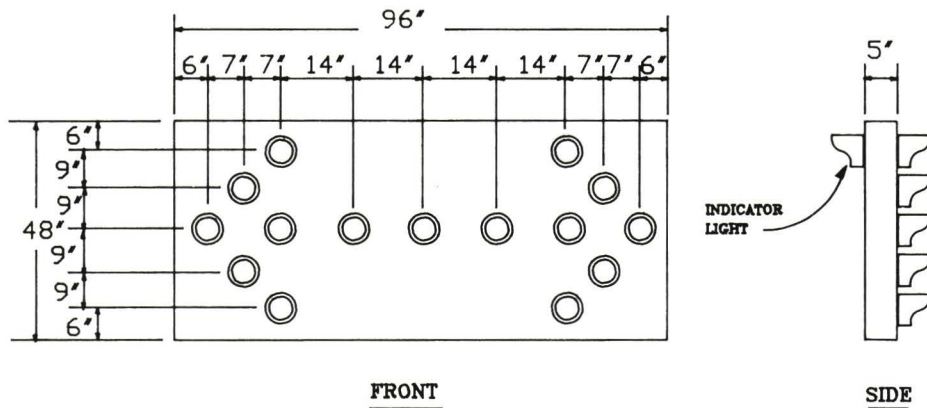


Figure 3. Lamp spacing details for the arrow panel ( 23 )



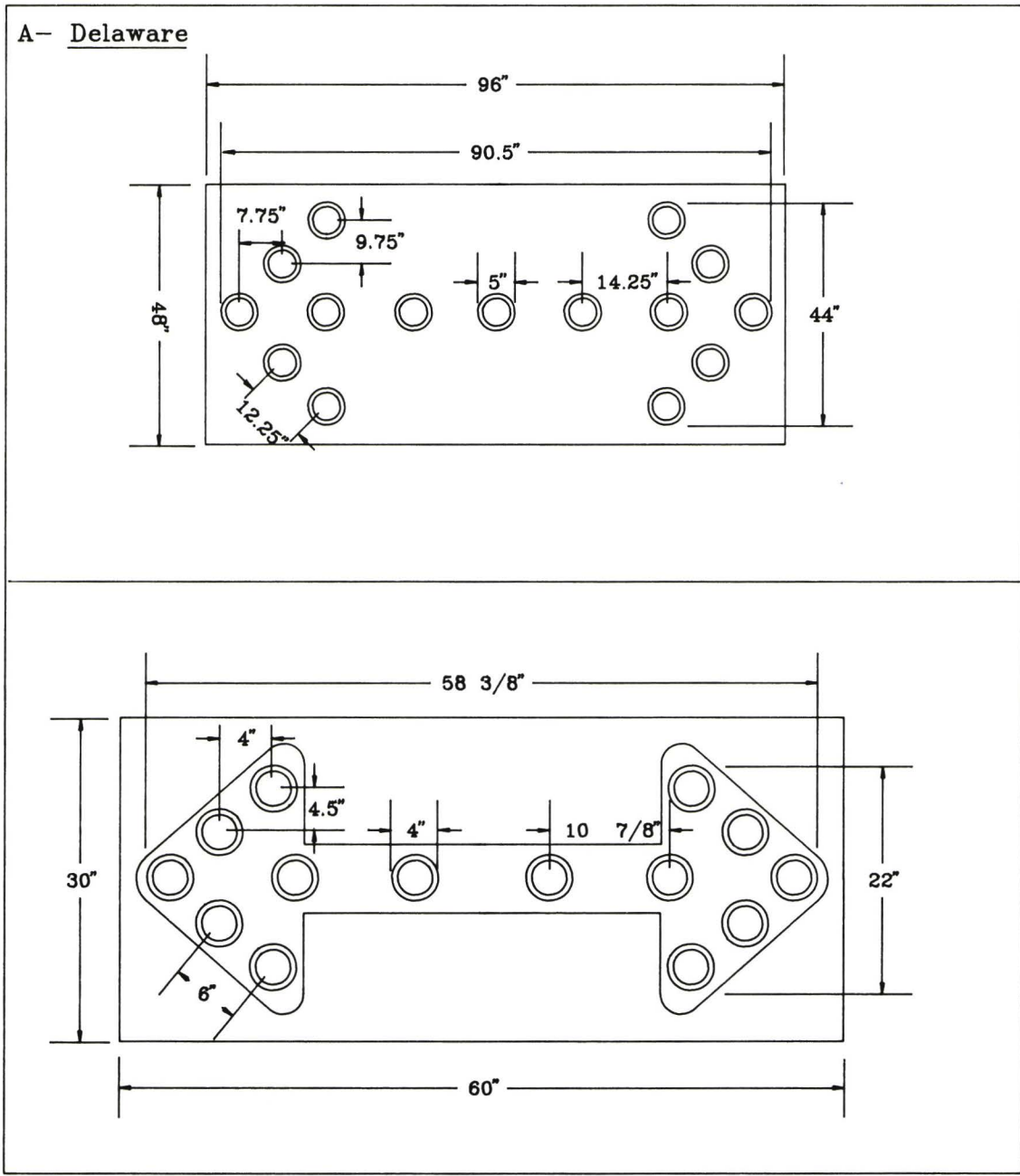


Figure 4. Lamp spacing details ( 20 . 17 )

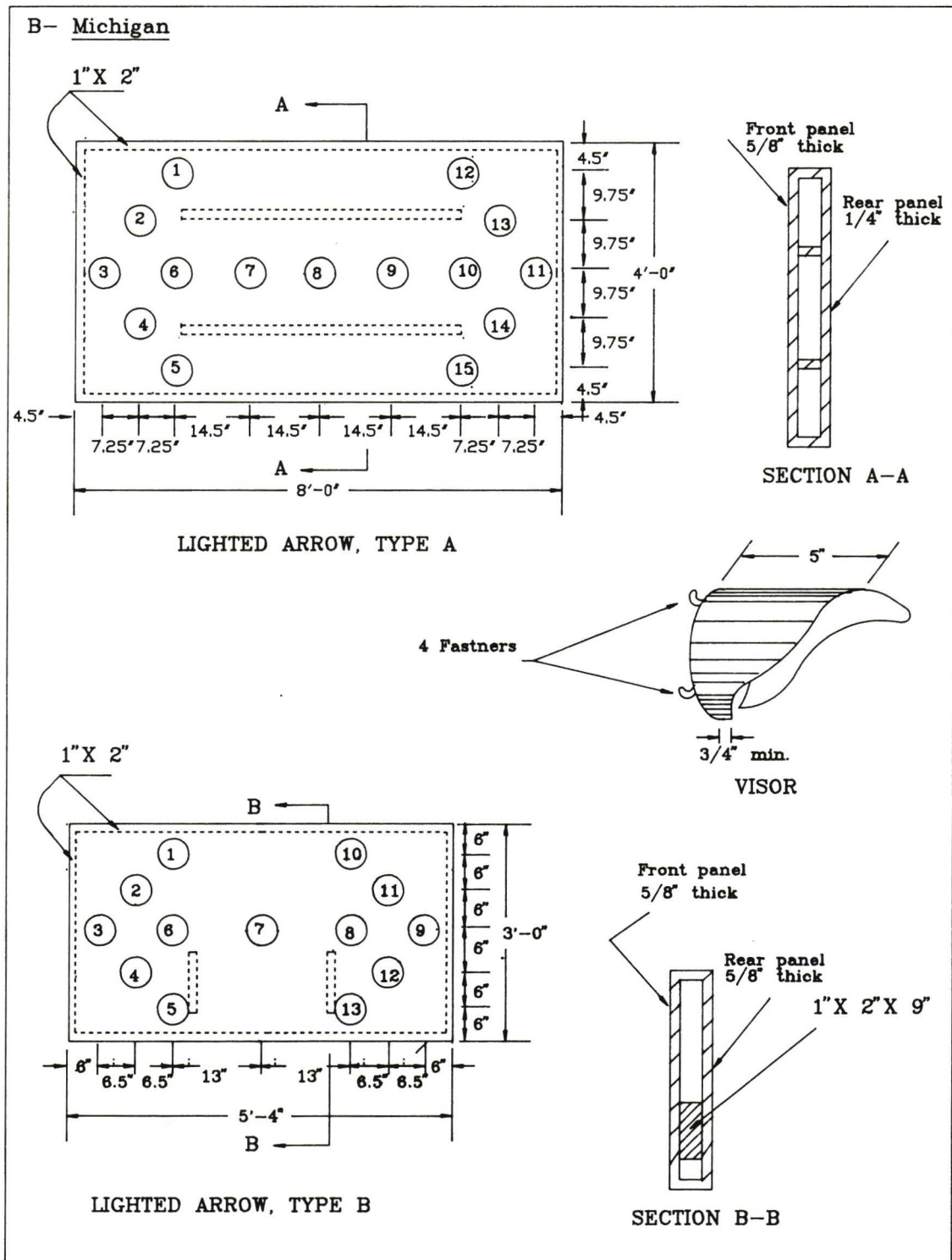


Figure 4. Lamp spacing details (Continued)



to five ambient foot candles and to restore the lights to normal at five to ten ambient foot candles. The state's specifications do not include provisions for test-point or voltmeter inspection. Manual dimming control of arrow panels is not commonly used with the larger arrow panel sizes; it is used frequently with smaller arrow panels (24" x 48").

5. **Power Supply.** The power supplies for arrow panels vary substantially between states. Some states require the trailer-mounted arrow panel to be powered by a self-contained engine-driven generator system which is capable of energizing the panel for 72 hours. Gasoline and diesel are the primary fueling sources, but solar powered arrow panels are also used. Some states allow the arrow panel to be energized from a utility company service. Some states do not specify any requirements. Most states, however, require the arrow panel to operate from power sources capable of continuously furnishing 12 volts direct current to the lamps for a minimum of 24 hours. Vehicle-mounted arrow panels are powered by a 12-volt automotive battery system.

Generally, the design specifications for arrow panels used by states are in compliance with those of the MUTCD and, in some cases, are more elaborate. There are subject areas, however, which are not addressed in the MUTCD or the state manuals. These include specifications on power source, mounting, and lamp size and spacing. The use of arrow panels indicates wide variation in specifications for each of the above. The MUTCD should be more explicit on the specifications that already exist in Section 6E-9, Part VI, and explore the other design specifications that could improve the effectiveness and operation of arrow panels.

The following section discusses the design specifications for mini-arrow panels that were provided by arrow panel manufacturers or suppliers.

**C. Design Specifications of Non-Standard Arrow Panels.** Non-standard arrow panels are those which do not meet one or more of the design standards set by the MUTCD. Of this group, the mini-panel applies to those with dimensions less than two feet in height and four feet in width and which have non-rectangular arrow-shaped panels. Mini-arrow panels are primarily used on low volume, low speed (< 35 mph) urban facilities. The common users consist of states, municipalities, utility companies, and contractors. Due to a lack of a local, state and national policy on mini-arrow panels, their design specifications can only be obtained from manufacturers and suppliers. Currently, state manuals do not contain any guidelines or present any typical illustrations of mini-panel applications. Tables 2 and

Table 2. Non-standard arrow panel specifications

Arrow Panel Models*	Rectangular Flat Black Frame	Size (HXW) In.	Weight (lbs)	Candle Power (Each)	Lamp Color	No. of Lamps	Lamp Size (in.)	Lamp Spacing (in.)
Model B	None	13x55	7	50	Orange	10	NI	NI
Model C	None (but optional)	24x60	25	1200	Yellow	14 (sealed beams)	4	NI
Model B	None	13x55	8	Lamp Type No. 1156	Yellow	10	4	NI
Model A	None	two 21x24	6	50 (not sealed beam)	Yellow	5 per arrow	4	NI
Model A	None	two 20.5 x 24	20	700	Yellow #4415A sealed beam	5 each arrow panel	4	NI

\* - See Figure 5 for Model Configuration

NI- Not Indicated

H - Height; W - Width; In - Inches; lbs - pounds

Table 3. Non-standard arrow panel specifications (Table 2 continued)

Arrow Panel Models	Power Supply	Sun Shades	Speed Restriction (mph)	Dimm. Cap.	Mounting	Operation
Model B	20 amps fused circuit, automotive 12 volt system	None	NI	None	Vehicle-mounted	Left, right, left & right, center bar
Model C	Standard 12 volt battery	(360 deg.)	Up to 55 mph	50 percent dimming operated manually	9 ft. above pavement; vehicle-mounted	Sequential directional modes left, right or in both directions 4-corner caution mode
Model B	12 volt; fuse protected	None	NI	None	Vehicle-mounted; magnetic or gutter mounts	Right, left; double arrow; & caution bar
Model A	12 volts; 11 amps at full load	1 in. sun shield (360 deg.)	NI	No specs.	Rear of or vehicle roof	Left; right; double arrow
Model A	12 volt;	(360 deg.)	NI	Manual switch	Vehicle top	Left; right; right & left; and flashing bar

NI - Not Indicated



3 present a summary of non-standard arrow panel specifications obtained directly from manufacturers. Figure 5 illustrates differences between the standard 24-inch x 48-inch arrow panel and non-standard arrow panels with respect to shape, dimension, and lamp configuration.

Nominal sizes of non-standard arrow panels are 13 x 55 inches, 24 x 60 inches, 20.5 x 48 inches, and 21 x 48 inches. These panels are constructed of either aluminum with a black baked enamel finish or flat black epoxy powder-coated aluminum. None of the mini-arrow panels described here is rectangular, of solid construction, and finished with non-reflective flat black. The weight of the mini-arrow panel varies between 6 and 25 pounds.

The lamp configuration on the mini-arrow panels are relatively the same. The lamp size is four inches and emits a yellow color exclusively. Spacing detail between lamps is lacking. The number of lamps per mini-arrow panel is ten or more. The 24-inch x 60-inch non-standard arrow panel has 14 lamps due to its larger panel area. The Model A (Figure 5) is comprised of two separate panels with five lamps in each. The total candle power varies substantially among non-standard panels; Model B has a candle power of 1000 in comparison to 17,000 for Model C.

The mini-arrow panel is usually mounted on the vehicle top or at the rear. The mounting height to the base of the panel varies between five and nine feet above ground. Greater heights could be obtained, however, by providing higher mounting brackets.

The control operation of the mini-arrow panels also varies significantly. Model C, for example, has the capability to flash at 60 flashes per minute while one brand of Model A has a maximum of 35 flashes per minute. Similarly, Model C has a 50 percent dimming capability, while Model B does not have a dimming feature. Dimming of the mini-panel, when available, is controlled manually. Sun shades are provided for a few of the mini-arrow panels.

The power supply of the mini-arrow panel is provided by a standard 12-volt battery.

**D. Crashworthiness of Arrow Panels.** The arrow panel is a vulnerable object because of its placement in the cone taper or at the rear of vehicles during mobile operations. Highway agencies are very concerned about the frequency of vehicle collisions with shadow vehicles equipped with arrow panels. Many agencies equip the shadow vehicles with truck-mounted crash attenuators. For stationary operations, the arrow panel is commonly used at the beginning of the taper. Although there is strong evidence of the effectiveness of arrow panels in reducing the number of vehicles in the closed lane, the

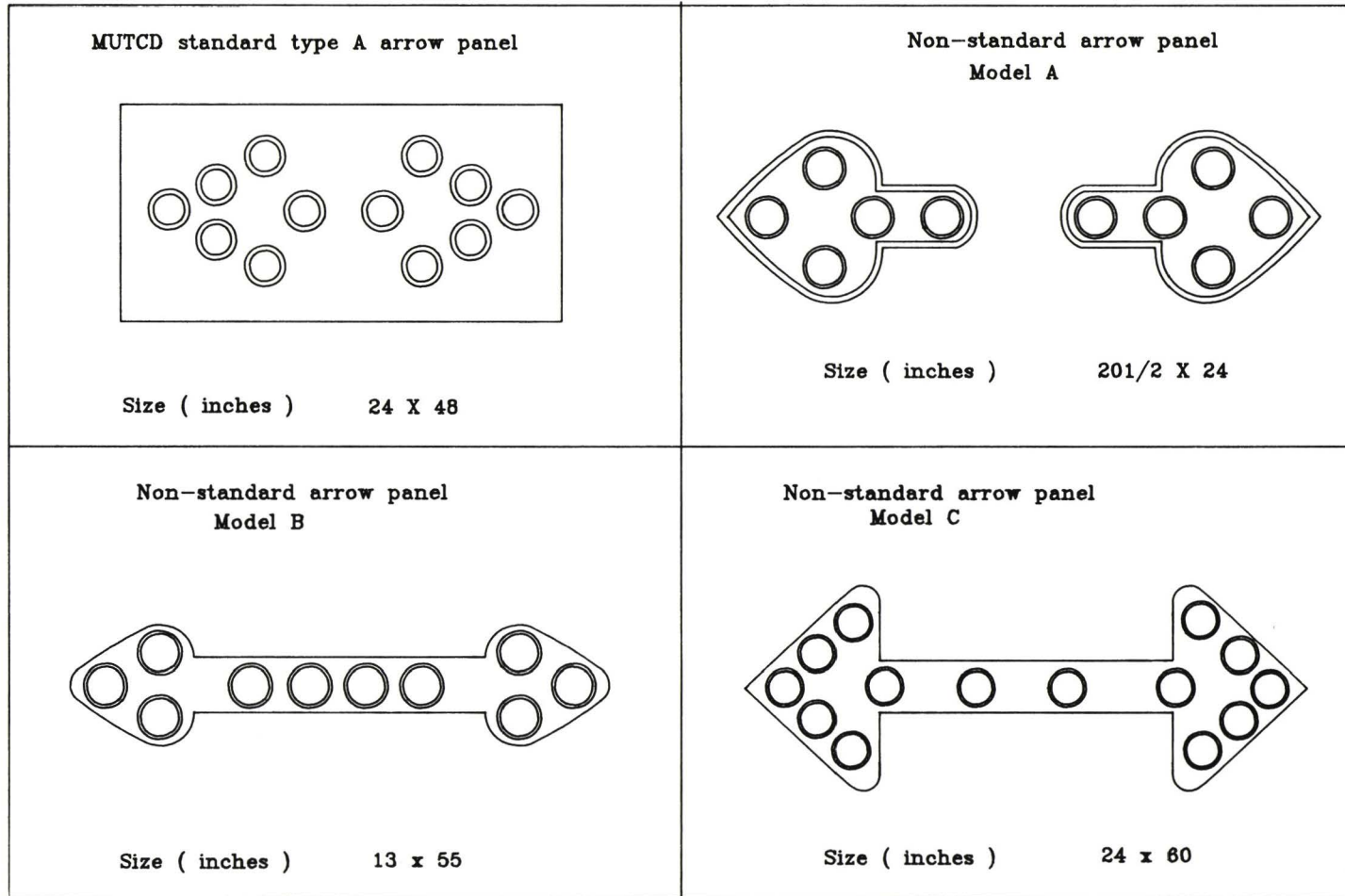


Figure 5. Configuration of standard and non-standard arrow panels.

potential for vehicle collisions with arrow panels and fire is not beyond expectation, especially since many trailer-mounted arrow panels are fueled with gasoline. Past research did not address the "crashworthiness" of arrow panels.



### III. APPLICATIONS IN PRACTICE

Standard arrow panels are generally used for stationary or moving-maintenance operations when a lane is closed. Arrow panels are also used in traffic splits and diversions (lane shifting) when construction and maintenance activities are conducted in the roadway.

Part VI of the MUTCD (1), presents general guidelines on the use of the arrow panel as an optional traffic control device. Today, however, the state-of-the-practice of arrow panels differs from that in the MUTCD. Table 4 demonstrates arrow panel applications as observed in a selection of state traffic control manuals. As it shows, the arrow panel is being utilized for almost all single and multiple lane closures as well as for partial roadway closures on divided and undivided freeways and local streets.

The cost of standard arrow panels range from \$750 to \$5,000 depending on size and accessories. Mini-arrow panels can be bought for less than \$250. Without regard for effectiveness, the relatively higher cost (acquisition and maintenance) and the cumbersome transport of large arrow panels have forced many municipalities and counties to consider non-standard and less labor-intensive mini-arrow panels. Generally, the mini-panels that are currently used do not meet the size and shape specifications of the Type A arrow panel (24 inches x 48 inches) in the MUTCD. Nevertheless, their use and application has spread widely, especially on city streets.

The following sections discuss the current use of standard and non-standard arrow panels as prescribed in the state manuals of Delaware, California, Illinois, Maryland, Pennsylvania, Ohio, Minnesota, Michigan, New York, Virginia, and the District of Columbia. Excerpts from state manuals and photographic illustrations of field applications are used to demonstrate the standard and non-standard arrow panel applications for single and multi-lane closures and for moving operations when a lane is closed.

**A. MUTCD Requirements.** The application of the arrow panel, as specified in the MUTCD and the Traffic Control Devices Handbook (TCDH) supplement, is relatively vague. The TCDH is intended to supplement the MUTCD by interpreting and linking the MUTCD's national standards with the activities related to complying with those standards. Although the MUTCD offers general guidelines for arrow panel use, it lacks adequate illustrations and specifications for arrow panel applications.

Table 4. Use of arrow panels in work zones

State	Lane Closure			Multi-Lane Closure		Moving Operation				Diver- sion
	Left	Right	Center	Left & Center	Right & Center	Left	Center	Right	Shoulder	
Maryland	*	*	(**)	(**)	(**)	*	NI	*	@	*
New York	*	*	*	*	*	*	(**)	*	**	**
Ohio	*	*	*U	(**)	(**)	*	*	*	*	**
Pennsylvania (optional)	*	*	(**)	(**)	(**)	*	NI	*	**	*
Illinois (optional)	*	*	NI	*	*	*	*	*	**	*
California (optional)	*	*	(**)	(**)	(**)	NI	NI	NI	**	*
Delaware	*	*	(**)	NI	NI	*	NI	*	NI	NI
Virginia	*	*	(**)	(**)	(**)	*	NI	*	@	**
Michigan	*	*	NI	(**)	(**)	*	NI	*	@	*

Sources: Reference No. (17, 18, 19, 20, 21, 22, 23, 24, 25)

- \* - denotes single arrow panel for single lane closure
- \*\* - denotes no use
- (\*\*) - denotes two arrow panels; one panel for each lane closure
- U - urban work zones
- NI - not indicated
- @ - denotes single arrow panel for shoulder work



The MUTCD implies that the arrow panel should be used for lane closures, diversions, and traffic splits. The MUTCD is specific, however, on conditions where arrow panels should not be used. Arrow panels should not be used where lane closures are not required, for work on or outside the shoulder that has no interference with adjacent through lanes, and on two-lane, two-way roadways that are controlled by flagmen. The caution mode (four or more lamps, arranged in a pattern which will not indicate a direction) application is also suggested by the MUTCD for stationary or moving work operations on or outside of the shoulder (1). The MUTCD guidelines appear to have been a good starting point from which states and local jurisdictions have adapted and subsequently advanced this practice.

**B. Current Use of Standard Arrow Panels.** This section discusses the application of standard arrow panels for stationary and moving-maintenance lane closures, diversions, and shoulders.

1. **Left and right lane closures.** In the majority of the states that were evaluated, arrow panels are almost always used when left and right lanes are closed for maintenance or construction on state maintained highways. This practice exists even though the states' MUTCDs indicate that the arrow panel is optional. Figures 6 and 7 are schematics from the Michigan and Maryland MUTCDs that illustrate the use of arrow panels for right and left lane closures on divided and undivided highways (17, 24). Figures 6 and 7 illustrate how the arrow panels are placed behind the channelizing devices and at the beginning of the taper. When shoulders are available, arrow panels are often placed at the beginning of the taper on the shoulder. When shoulders are not present, arrow panels are placed on the lane. Figure 8 shows the use of arrow panels for lane closures in Michigan and Pennsylvania. Based on observations of several work sites in the states and local jurisdictions visited, it appears that the states are conforming to the use of the MUTCD standard arrow panels (30 x 60 inches or 48 x 96 inches) for state maintained highways, particularly in high-density urban freeways.

Discussions with officials from municipalities indicate that the arrow panel is very effective on arterials and local streets where the driver's advanced view of the work zone is restricted. Urban work sites, however, present a unique challenge. Frequently, road geometrics coupled with the road construction or maintenance activities do not allow the installation of the required minimum taper length or an ideal traffic control setup. In many



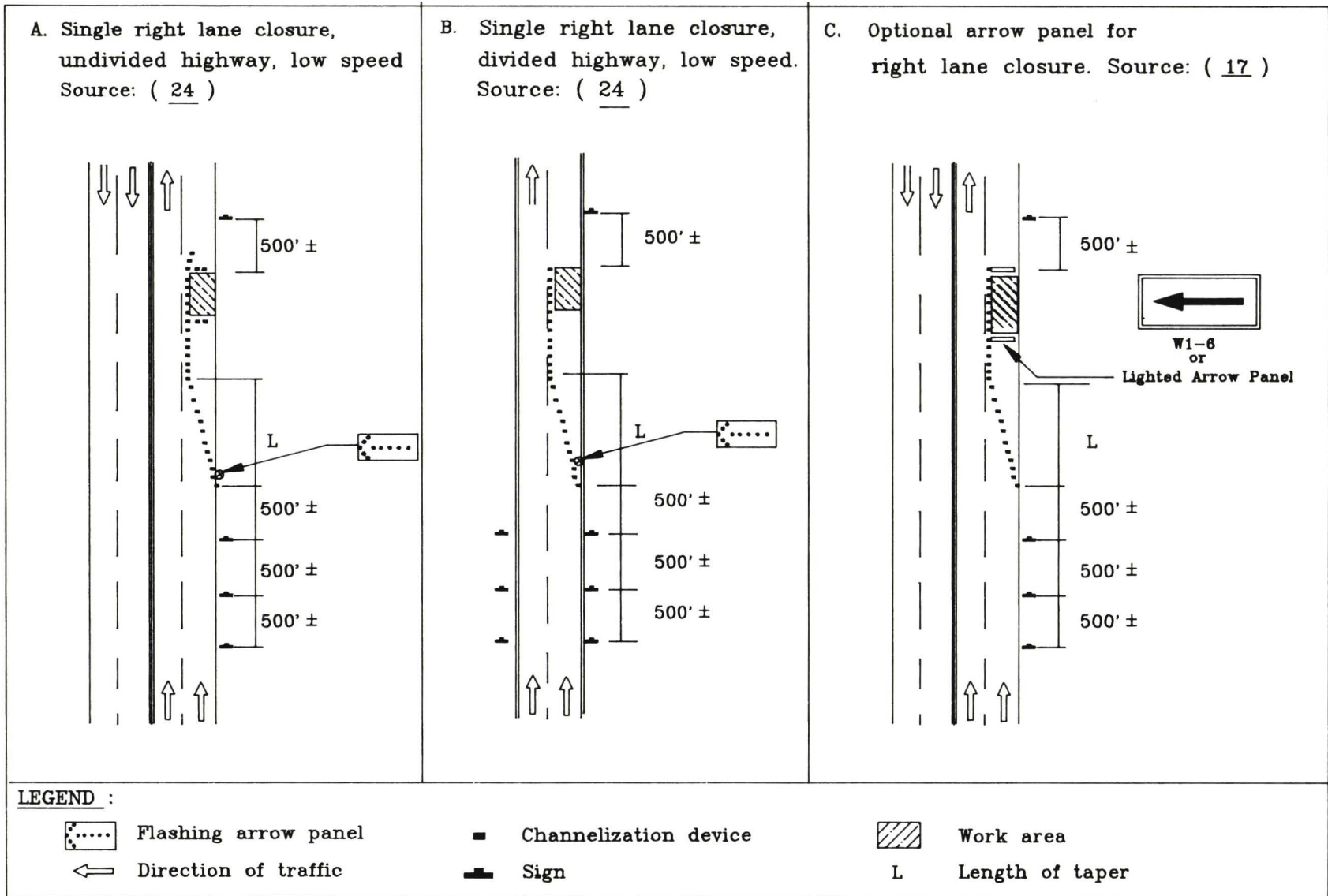


Figure 6. Application of the arrow panel in typical right lane closures

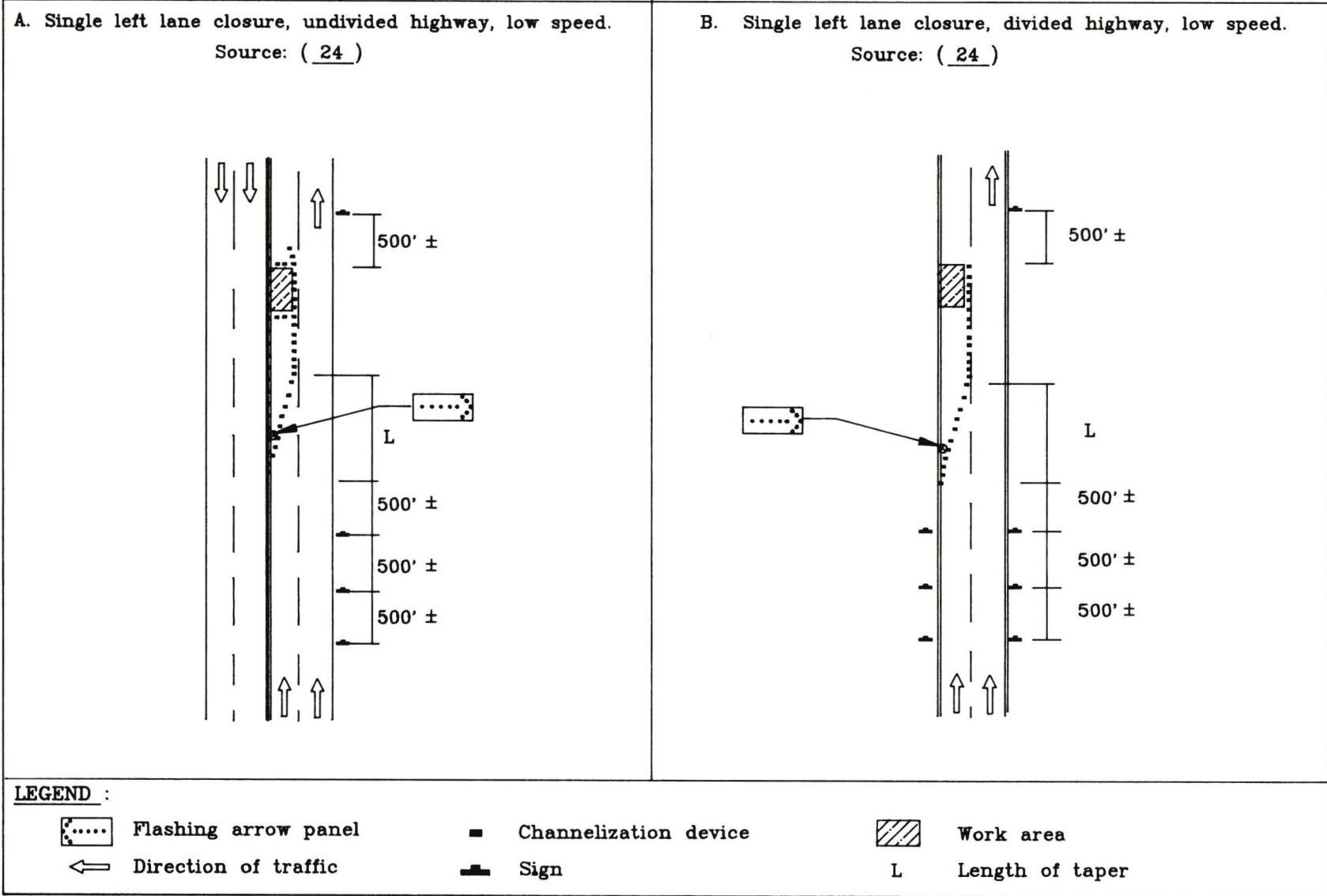
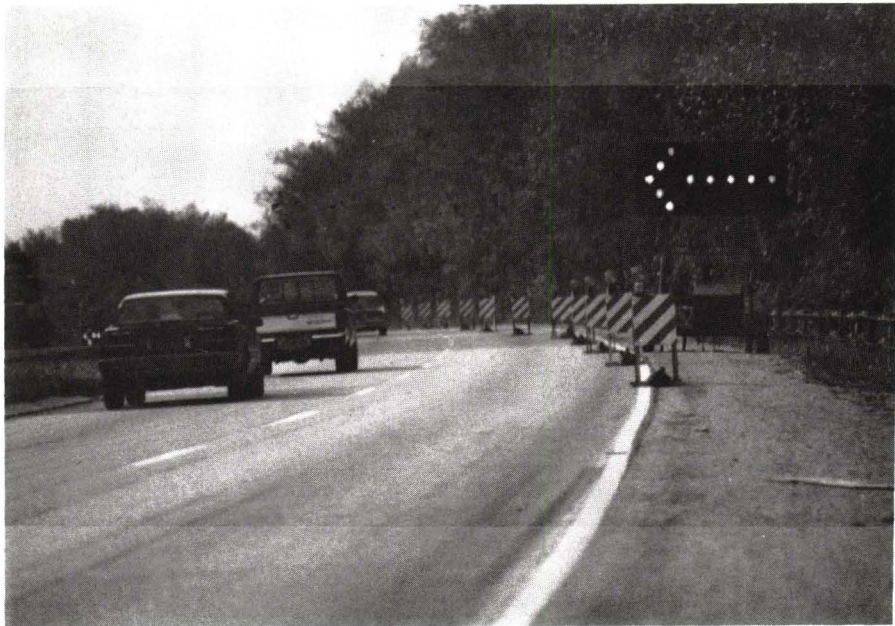


Figure 7. Application of the arrow panel in left lane closures



(a) Michigan



(b) Pennsylvania

Figure 8. Placement of the arrow panel for typical right lane closures in Michigan and Pennsylvania



situations, the taper must be made shorter than minimum requirements, or in some cases is not installed. Observed practice, in these situations, is the use of large trailer-mounted arrow panels to insure longer effective visibility to the work area. Photographs shown in Figure 9 are representative of typical urban arterial work sites.

The use of a supplementary arrow panel (a second arrow panel located on the shoulder upstream of the lane closure) to increase the effective sight distance for a right- or left-side freeway lane closure when the sight distance to the work area is restricted (less than 1500 feet) was not observed in any of the states visited. Most of the sites visited, however, had adequate site distance to the work area and did not require supplemental arrow panels. The state officials interviewed concurred with the recommendations of Faulkner and Dudek (6) and recognized the value of a supplemental arrow panel when the sight distance to the work area is restricted. They also recognize, as Faulkner and Dudek caution, that the supplemental arrow panel should not be placed too far upstream from the work area. Illinois, for example, supports the use of a supplementary arrow panel if deemed necessary by field measurements of sight distances.

2. **Center lane closures.** Maintenance work in the median lane or shoulder lane of a six-lane divided highway is generally accommodated by the closure of a single lane. Closure of either of these exterior lanes is relatively easy to achieve and, compared to more extensive traffic control requirements (i.e., detours, crossovers, and multi-lane closures), this approach has a minimal effect on traffic operations.

The multi-lane closure strategies illustrated in Figure 10 are commonly used to accommodate work in the middle lane. The multi-lane closure strategy involves closing an exterior lane and one or more adjacent middle lanes. The major disadvantage of the multi-lane closure strategy presented in Figure 10 is the resulting loss of highway capacity. Field studies conducted by Dudek and Richards (12) indicated that an average of only 1100 vehicles per hour can be accommodated on the one available open lane. On high-volume highways, this would result in considerable traffic congestion and delay. In recent years, highway agencies have used the traffic control strategies shown in Figures 11A and 11B as a means of conducting maintenance on the middle lane and accommodating traffic. This approach was first reported by Richards and Dudek (31) and was found to

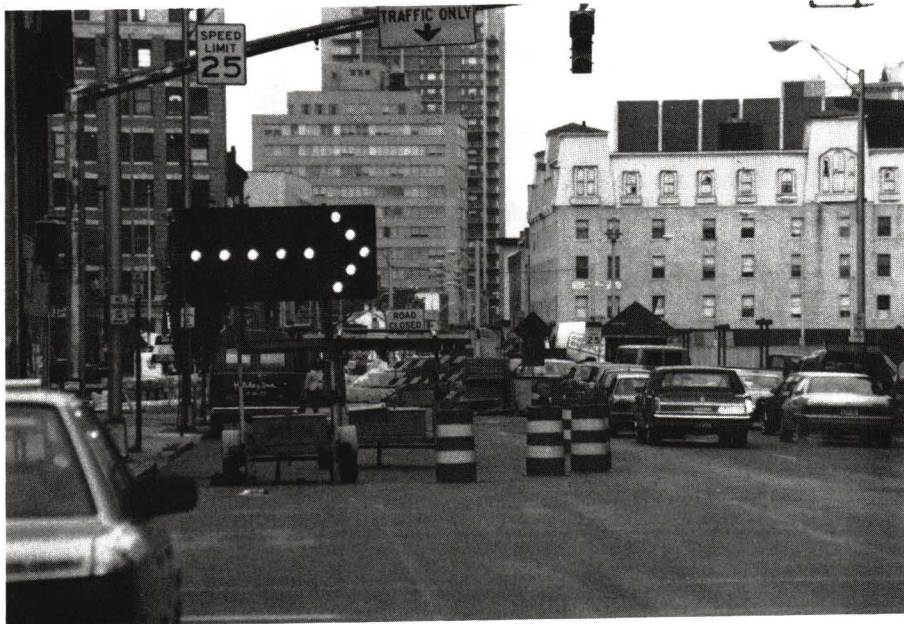


Figure 9. Application of the arrow panel in lane closures on local streets



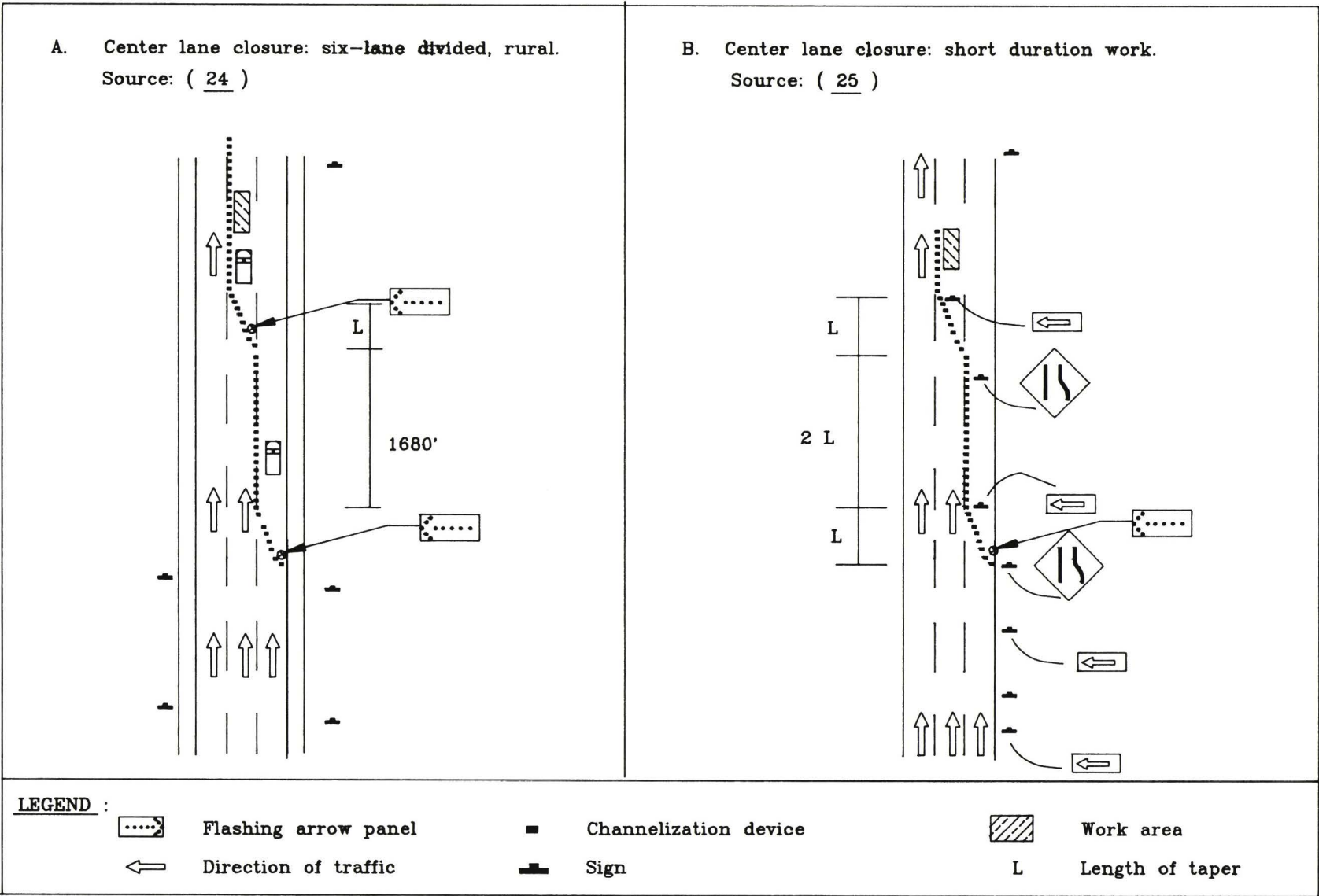


Figure 10. Arrow panel applications in multi-lane closures.



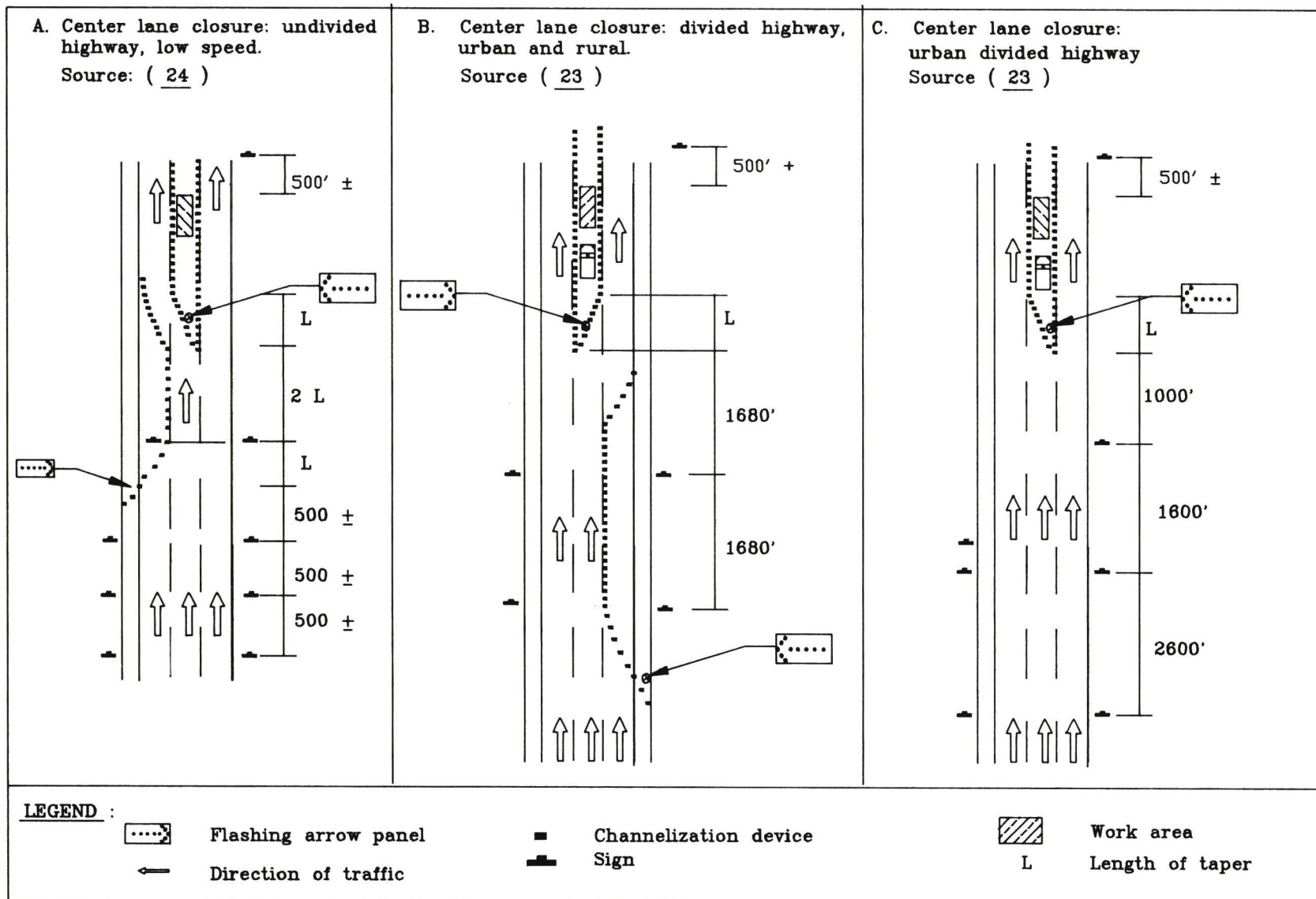


Figure 11. Arrow panel applications in center lane closures on urban and rural roadways

be very effective. It was estimated that traffic volumes up to 3000 vehicles per hour could be accommodated. The major advantage of the traffic control strategies shown in Figures 11A and 11B is that they minimize driver confusion by closing one lane and then "funneling" drivers to the left and right side of the work area. Drivers are not required to make a choice (left side or right side) because the traffic "funnel" positively directs drivers to the proper path. In contrast, the traffic control strategy shown in Figure 11C requires drivers in the middle lane to make a choice and can therefore be very confusing. The traffic control strategy shown in Figure 11C is not widely supported or used. Its use is limited to exceptional cases and at low-speed (35 m.p.h., or less) urban facilities.

Figures 10A, 11A and 11B illustrate the use of multiple arrow panels. Based on discussions with state and city highway officials, the use of two arrow panels for middle lane closures on six-lane divided rural highways is becoming the preferred practice in the states surveyed.

Concerned about the need to ensure positive guidance when multiple arrow panels are used in center lane closures, the Federal Highway Administration is contemplating revising Figure 6-17 of the TCDH. Preliminary ideas for the revision are indicated in Figure 12. Note the use of one arrow panel instead of two and a line of barrels leading into the taper that closes the center lane.

3. **Multi-lane closures.** Multi-lane closures are situations which involve closing either the left or right lanes and one or more adjacent middle lanes on divided highways having six or more lanes. The MUTCD suggests the use of one arrow panel for multi-lane closures (1). However, most of the states visited are currently using multi-panels; one panel for each lane closed. The state-of-practice in the states visited regarding multi-arrow panel use is to place the first panel on the shoulder at the beginning of the taper and the second panel at the beginning of the second taper behind the channelizing devices. The spacing between the two arrow panels is generally equal to the length of three tapers. Figure 13 illustrates a typical multi-lane closure where single or multiple arrow panels are being used.

Although state manuals may still show a single arrow panel for multi-lane closures, the majority of the states visited now support the use of two arrow

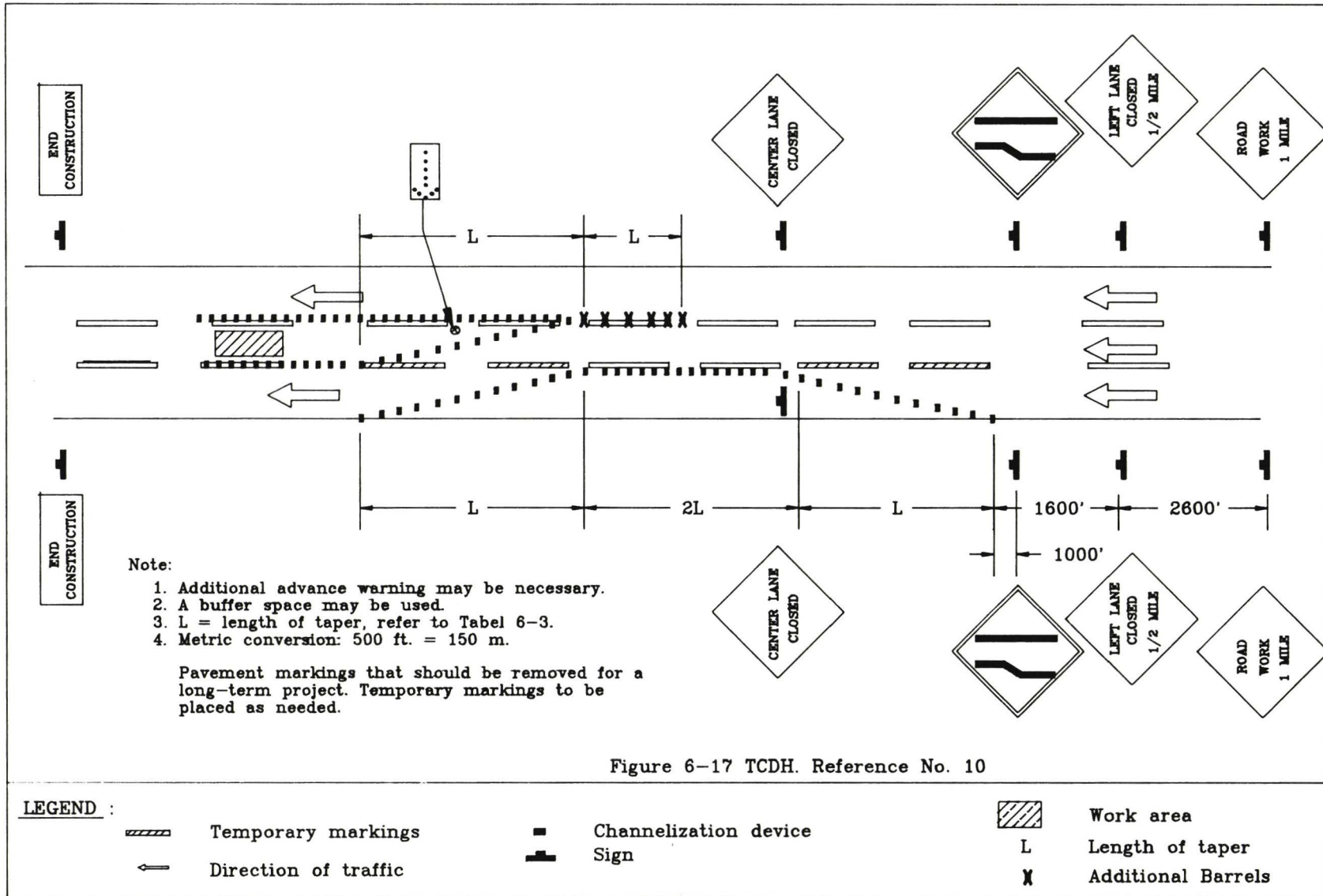


Figure 12. Proposed TCDH revision for use of one arrow panel in center lane closure.



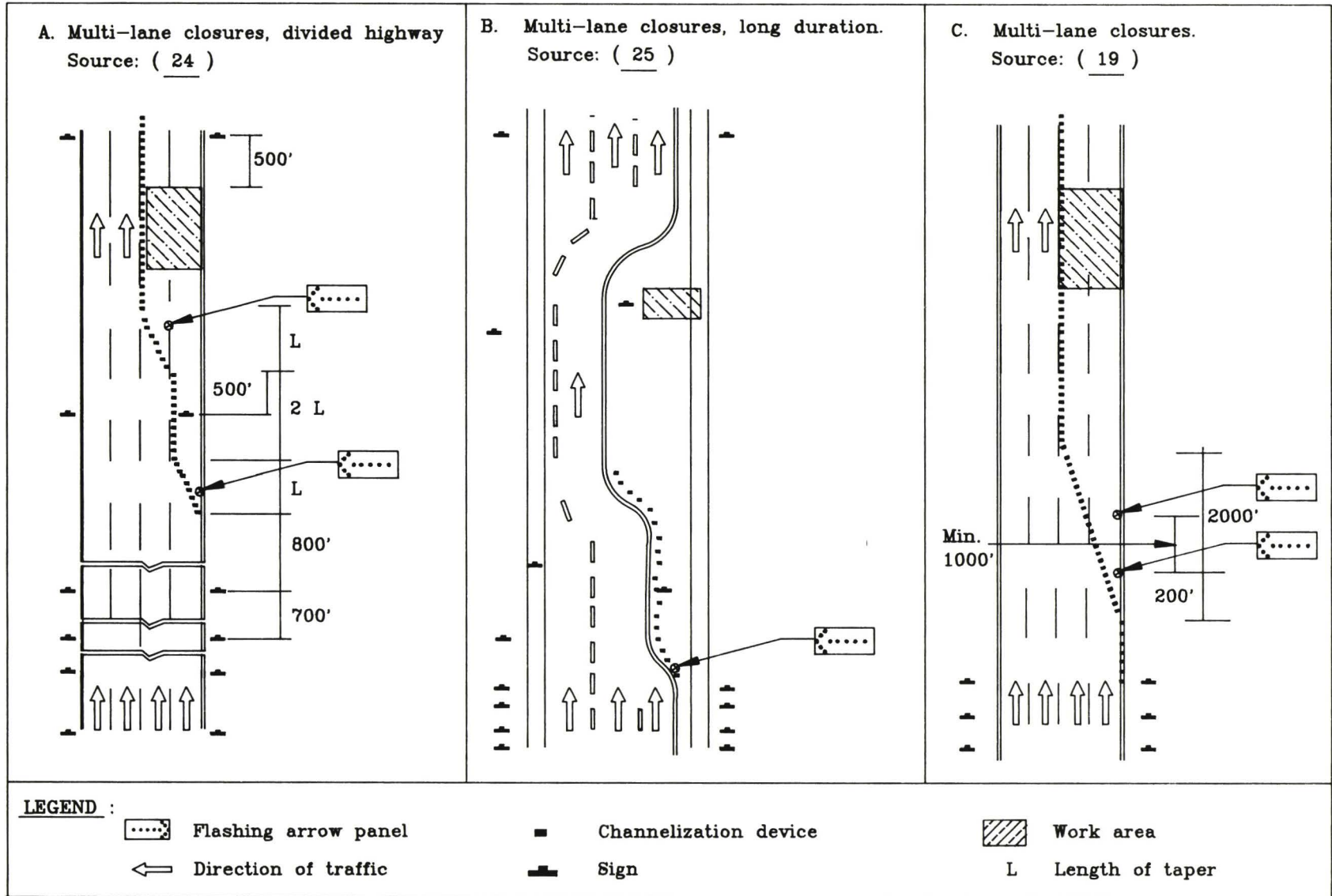


Figure 13. Application of arrow panels in multi-lane closures.

panels as illustrated in Figure 13A. In conditions where the desirable spacing between the two panels cannot be met, such as in urban areas, a minimum of 1000-1500 feet spacing between the two panels is usually recommended. The reason for this minimum spacing criterion is that approaching motorists will be less confused if they are allowed to view only one panel display at a time. Thus, a spacing of 1000-1500 has been recommended by practitioners as the minimum spacing between two panels.

4. **Moving maintenance lane closure operations.** Moving maintenance operations where a lane is closed on urban roads or freeways are conducted at speeds less than 25 miles per hour. Common moving maintenance activities include pavement milling and resurfacing, sweeping, pavement striping, median or shoulder maintenance, and grass spraying and mowing. For mobile operations, the MUTCD suggests the arrow panel be placed at the rear of the activity in the closed lane on a vehicle separate from the maintenance vehicle itself. The MUTCD does not distinguish between urban and rural operations.

The majority of the states visited followed MUTCD recommendations. States will either have arrow panels mounted on the back of maintenance vehicles or will use trailer-mounted arrow panels that are pulled behind the maintenance vehicle. Figure 14 illustrates the use of trailer-mounted arrow panels for right lane closures. Schematics for moving maintenance operations for the states of Delaware, Illinois and New York are shown in Figures 15 through 17. As noted, all three states specify the use of at least one arrow panel. This is also specified in the manuals of the other states surveyed.

A flashing arrow or sequential chevron arrow panel is not appropriate for lane closures on two-lane, two-way roadways. An arrow flashing to the left gives drivers the false indication that it is safe to proceed to the left side of the maintenance vehicle into the lane of opposing traffic. Therefore, when a lane is closed on a two-lane, two-way roadway, the arrow panel is placed in the caution mode. Figure 17B illustrates the use of a four-corner flashing caution mode used in the State of New York.

5. **Shoulder closure.** Shoulder activities include shoulder reconstruction, maintenance, trash removal, sweeping, grass spraying and mowing, and slope treatment. In the majority of cases, conventional





Figure 14. Moving-maintenance lane closure on urban arterials



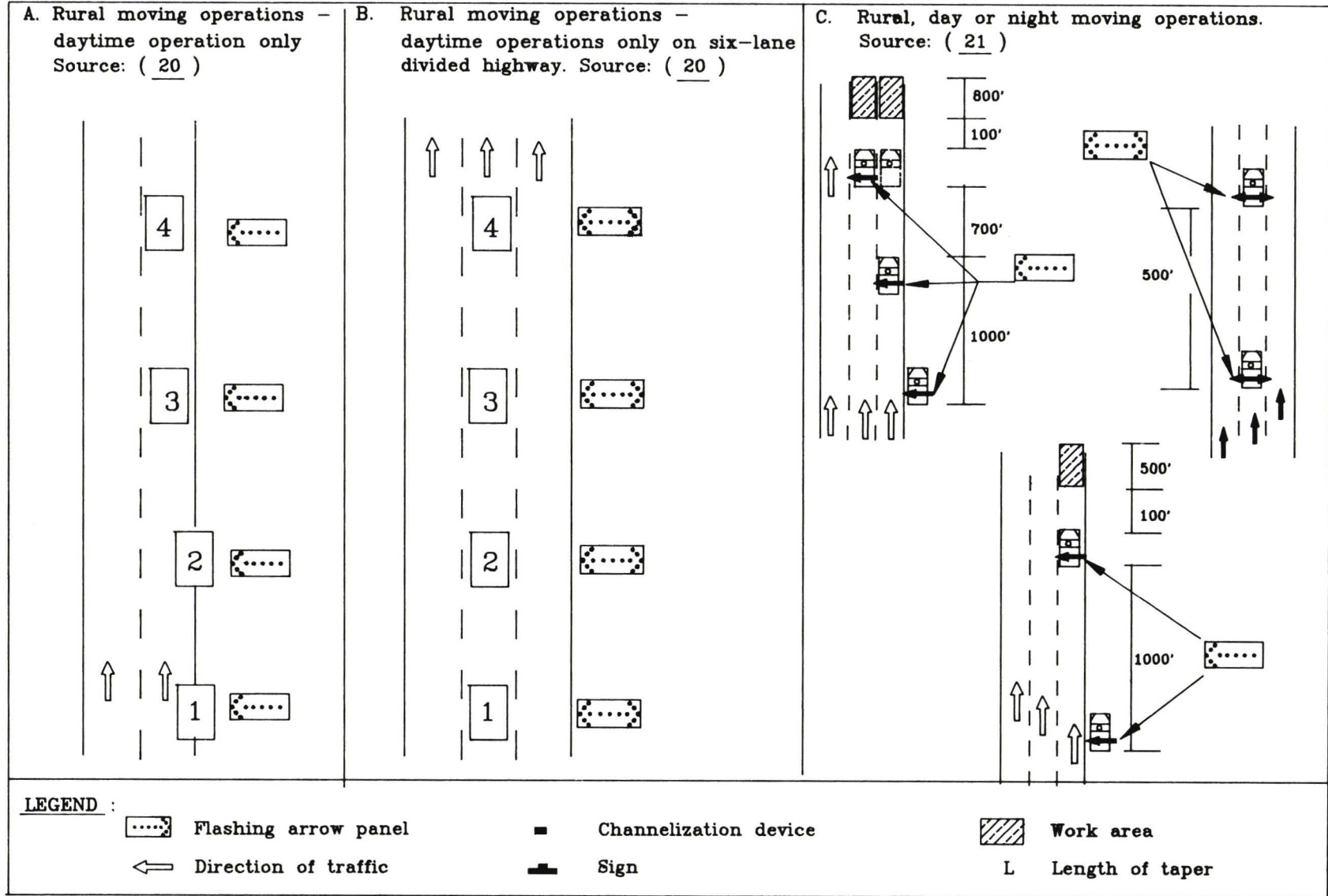


Figure 15. Application of the arrow panel in rural moving operations on four and six-lane divided highways.

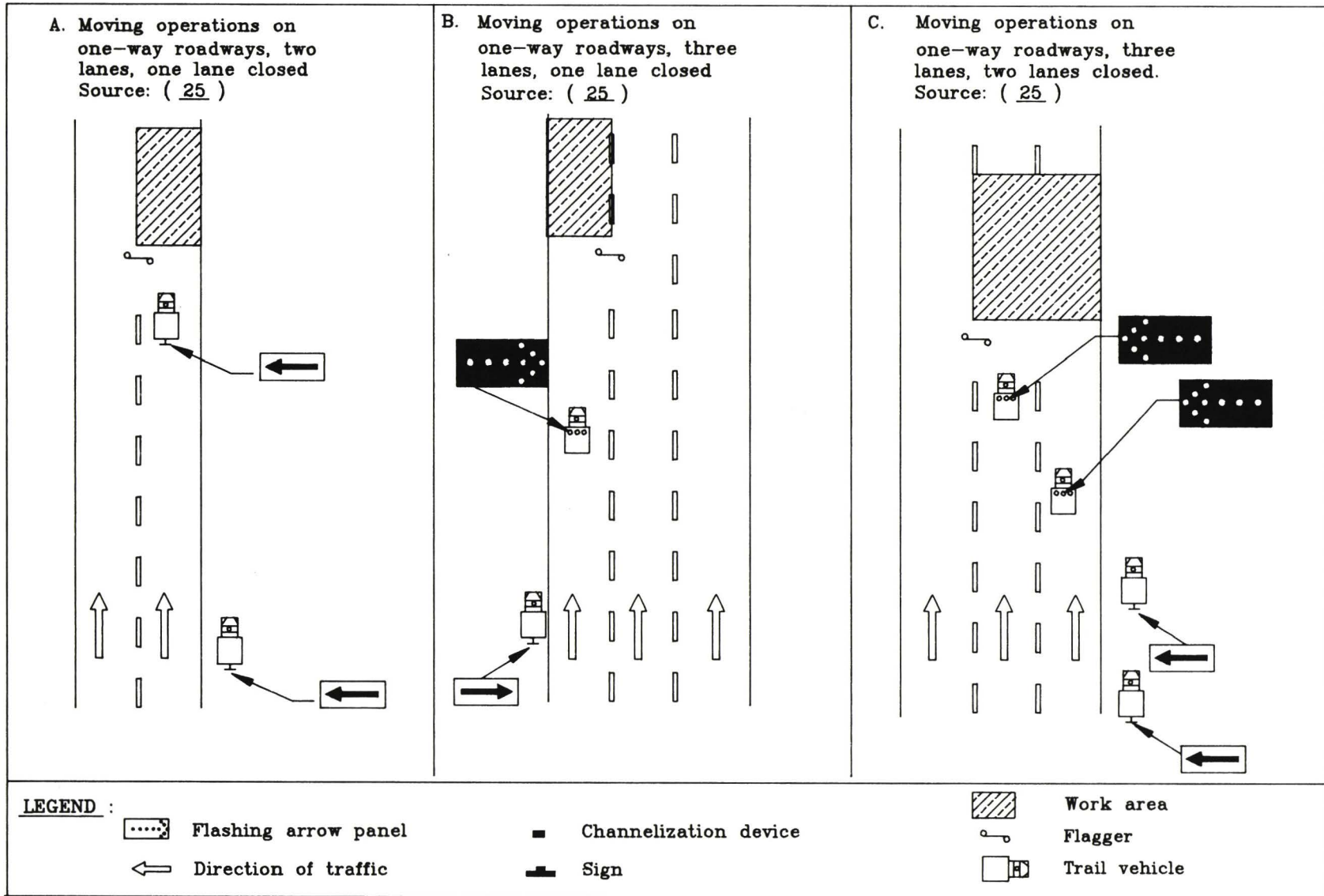


Figure 16. Application of the arrow panel in moving operation for single and multi-lane closures.

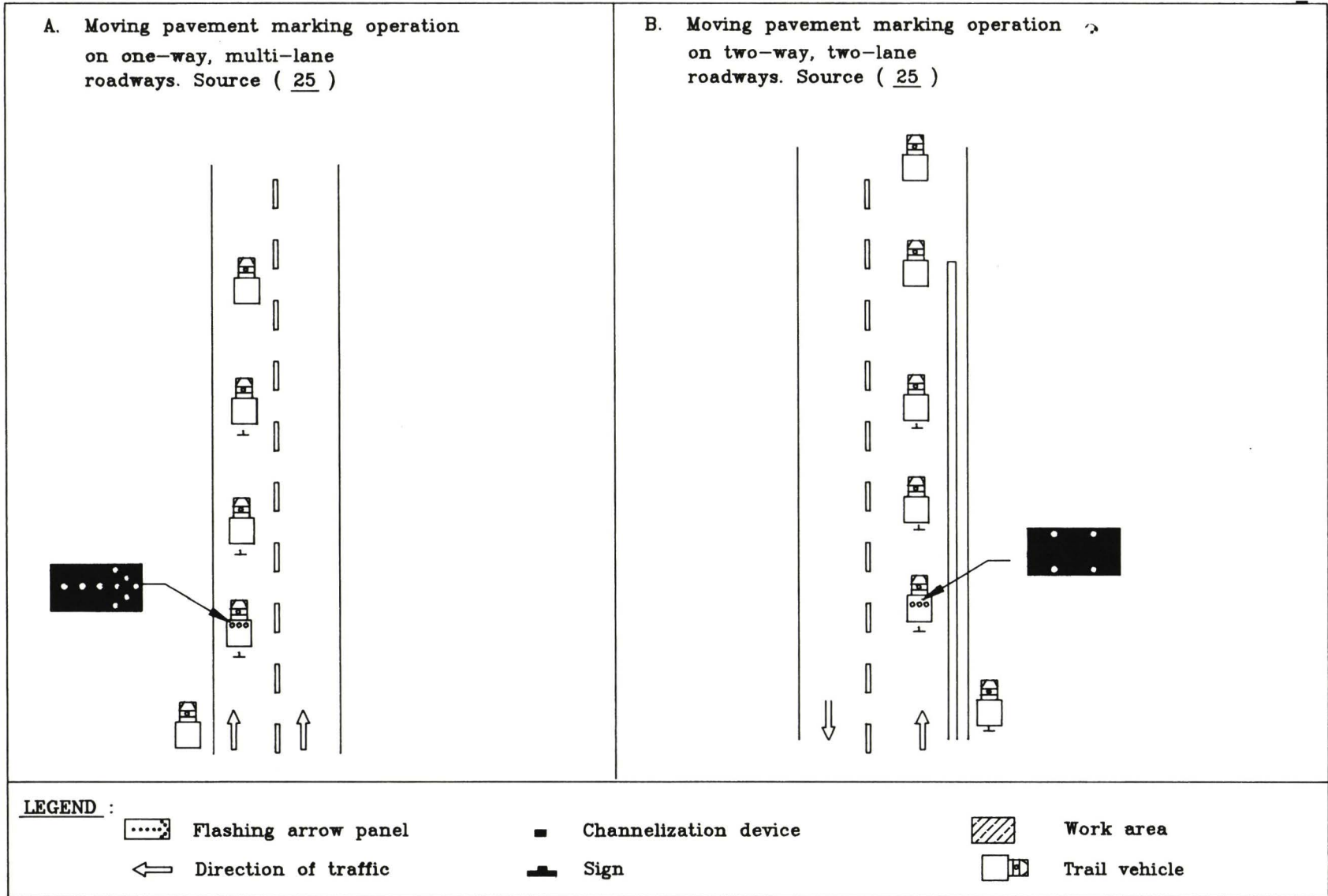


Figure 17. Application of the arrow panel for moving operations.



advance warning signs are adequate to alert motorists of work ahead. However, the arrow panel has become the preferred traffic control device especially for moving maintenance operations.

There seems to be unanimous agreement that a flashing arrow or sequential chevron should not be used for shoulder closures (unless the shoulder lane is closed or encroached by the work vehicles on divided highway). All eight states visited use the caution mode when arrow panels are used during shoulder work. Maryland, New York, and Delaware use the caution four corner flashing mode; whereas, Pennsylvania and Virginia only specify the caution flashing bar mode.

There is concern on the part of some researchers and highway agencies that the caution flashing bar may be interpreted by drivers as a malfunctioning flashing arrow resulting in unnecessary lane changes. Consequently, some agencies prefer the four-corner flashing mode for caution displays.

Figure 18 shows photographs of the caution flashing bar mode during a shoulder closure. Figure 19 illustrates traffic control during shoulder closures in Ohio.

6. **Lane diversions.** Lane diversions frequently occur with partial roadway closures (e.g., lane shifts) or complete roadway closures (e.g., crossovers). When a lane is closed in a crossover traffic strategy, it is useful to use a flashing arrow for the lane closure. Officials in eight states offer a mixture of opinions about the use of the flashing arrow panel in the flashing arrow or sequential chevron modes for lane diversion when a lane is not closed. Although these modes are used extensively, some officials argue that such applications are unsafe and weaken the credibility of the arrow panel because the flashing arrow and sequential chevron are perceived by drivers as lane closure rather than lane diversion information. This driver misunderstanding was found in laboratory studies conducted by Graham et al. (7). Some officials further believe that arrow panels should not be used routinely for lane diversions, and that their drawbacks should be studied prior to continued use.

Figure 20 demonstrates crossover traffic control strategies in Maryland using arrow panels when a lane closure is included. Figure 21 illustrates the arrow panel placement for crossovers involving a lane closure. Figure 22 illustrates a situation where the



Figure 18. Application of the caution bar mode for shoulder closure

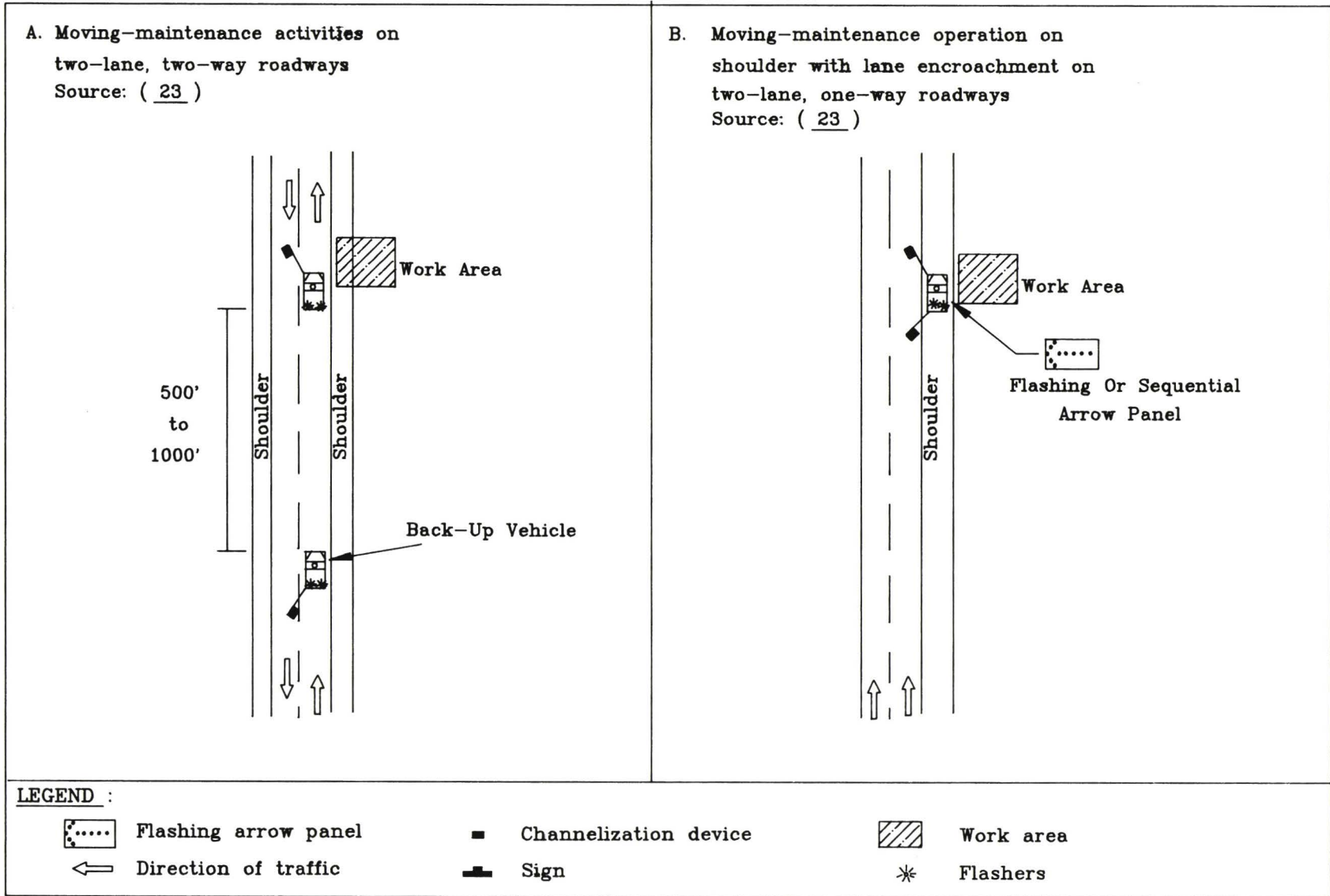


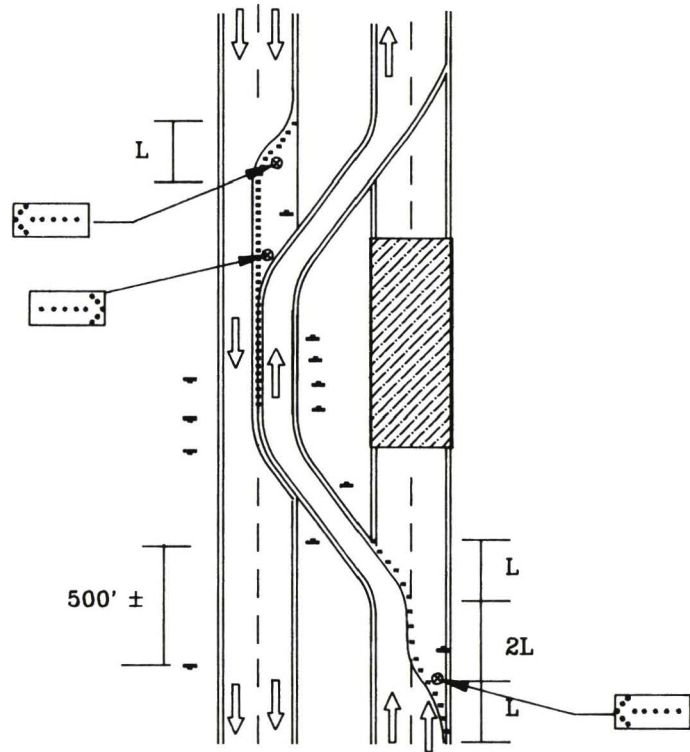
Figure 19. Traffic control for shoulder closure.



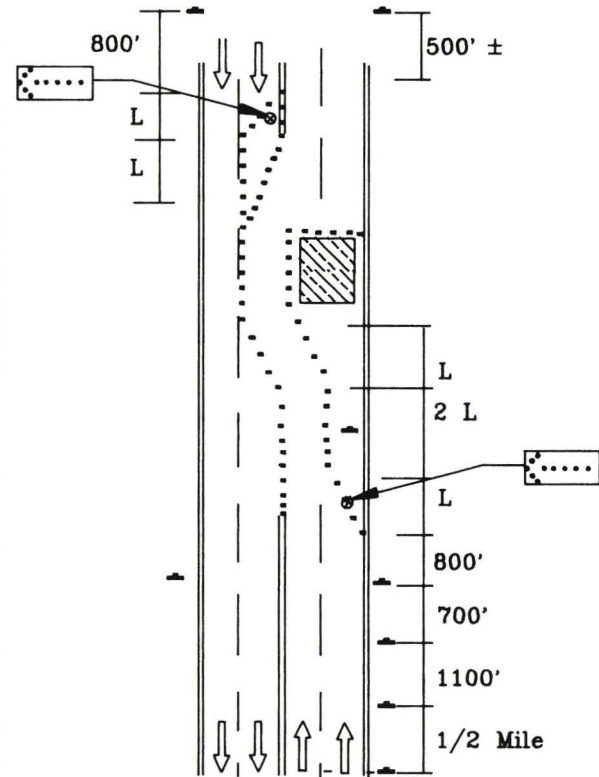


Figure 20. Application of the arrow panel in crossovers

A. Roadway closure on four-lane divided highway with lane diversion.  
Source: ( 24 )



B. Partial roadway closure, with lane diversion on undivided highway.  
Source: ( 24 )



**LEGEND :**



Flashing arrow panel



Channelization device



Work area



Direction of traffic



Sign



Length of taper

Figure 21. Application of the arrow panel in crossovers with lane reductions

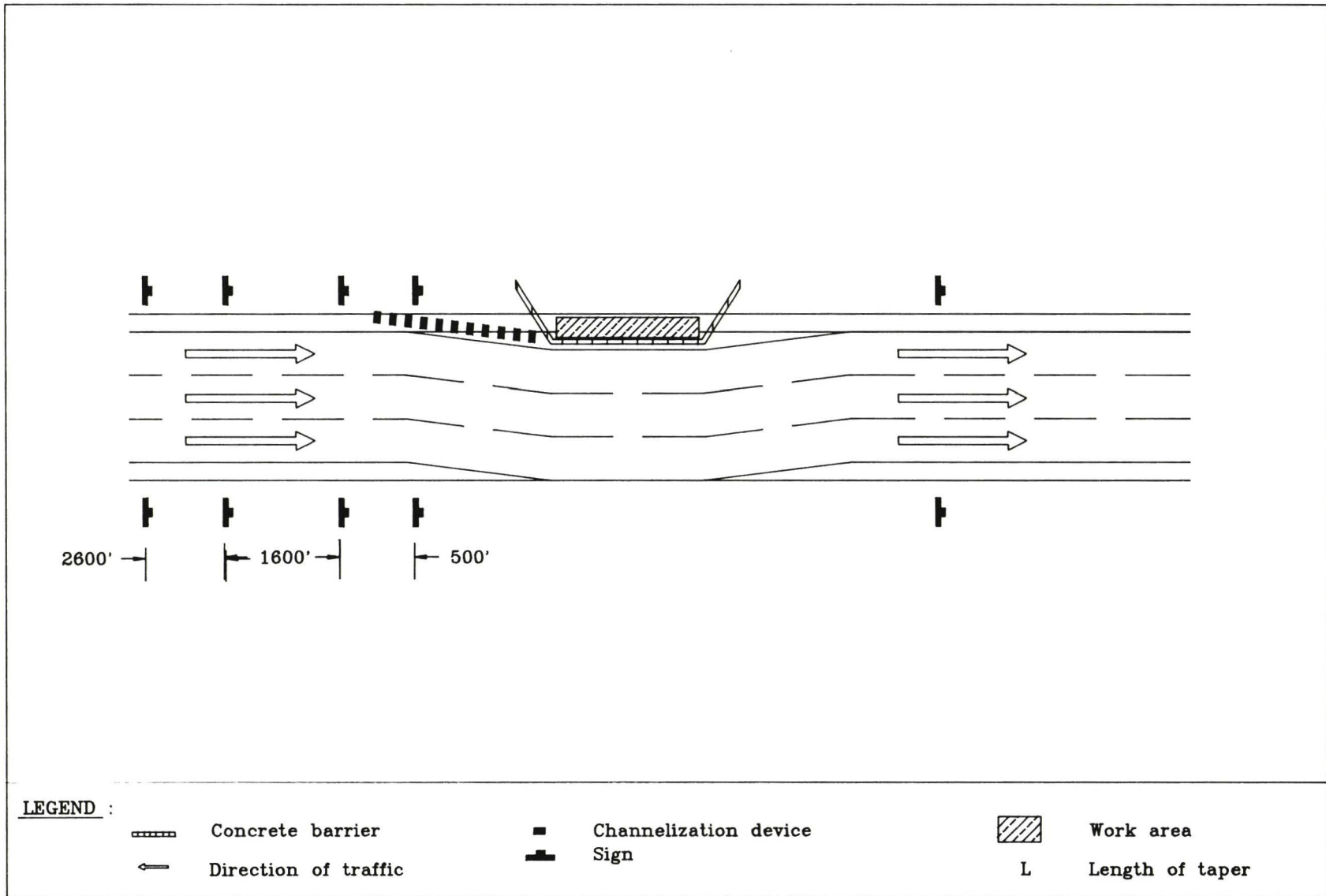


Figure 22. Lane shift without lane closure and arrow panel.



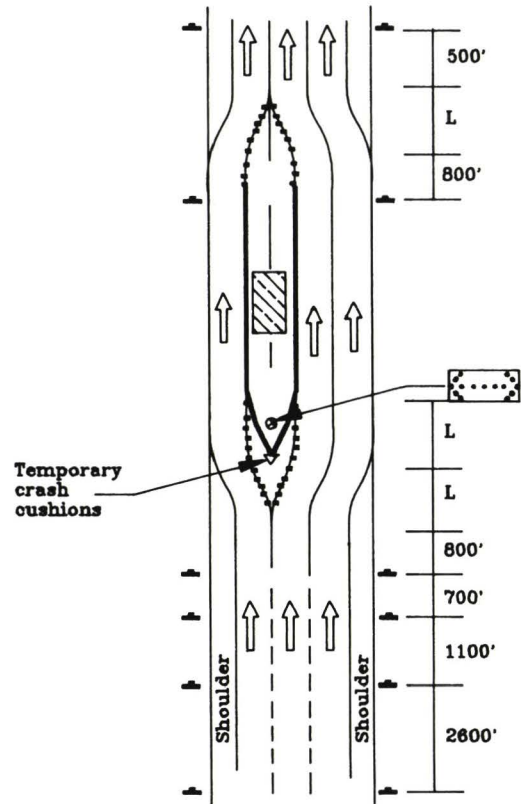
alignment of all lanes is slightly shifted and traffic is controlled without arrow panels.

7. **Traffic splits.** Standard, large traffic-split warning signs (W12-1) have been used behind lane closure barricades to warn drivers of the lane split condition. Recently, the arrow panel with a double arrow flashing mode has been used to supplement the sign and provide advance notice of the split. Most of the highway officials interviewed believe that the flashing double arrow display demands driver concentration and tends to cause confusion. Figure 23 is a schematic from Maryland of an arrow panel application in a traffic split incorporating the shoulder as a temporary lane.

**C. Summary of Current Practices.** By and large, the current practices observed in California, Illinois, Maryland, Michigan, New York, District of Columbia, Pennsylvania, and Virginia offer some useful information on the application of arrow panels, especially for stationary and mobile lane closure situations. The salient observations are summarized below.

1. State and local highway officials agree unanimously that the arrow panel is a very effective traffic control device in promoting earlier merging into the open lane and in diverting, and controlling traffic around construction and maintenance activities being conducted on or adjacent to the traveled roadway.
2. The arrow panel is immensely popular and is currently widely used in rural and urban work sites.
3. The arrow panel is widely used at long-term left or right lane closures on all facilities other than two-lane, two-way roadways.
4. Some states use supplemental arrow panels (a second arrow panel) for lane closures with restricted sight distances (less than 1,500 feet) on high-speed highways.
5. Use of arrow panels for middle lane closures varies among the states.
6. Multi-arrow panels are used for multi-lane closures.
7. Arrow panels are used by all the states for moving maintenance operations. The states use both single and multi-arrow panels. The number of arrow panels varies among states.

Lanes divide: traffic splits and shoulder usage.  
 Source: ( 24 )



**LEGEND :**






- |   |                      |   |                       |   |                 |
|---|----------------------|---|-----------------------|---|-----------------|
|  | Flashing arrow panel |  | Channelization device |  | Work area       |
|  | Direction of traffic |  | Sign                  | L   | Length of taper |

Figure 23. Application of the arrow panel in typical traffic split.

8. For shoulder closures and for lane closures on two-lane, two-way roadways, the caution mode of operation is used. The four-corner flashing panel appears to be the preferred choice of most states.
9. Lane diversions and traffic splits are special conditions for arrow panel applications. State officials indicate that the arrow panel in these cases demands more of drivers. Most states have developed typical drawings that illustrate arrow panel applications.
10. The 48-inch x 96-inch arrow panel is the most popular of the three standard panels, even in urban work zones. The 30-inch x 60-inch arrow panel was observed only for mobile operations on moderate speed (45 miles per hour). The base mounting height of the trailer-mounted and truck-mounted arrow panels was approximately 7 to 8 feet.
11. Based on discussions with several state highway officials, there appears to be interest in specifying highway speed ranges for each standard arrow panel. A few states have already defined these ranges.

**D. Current Use of Non-Standard Arrow Panels.** The MUTCD specifically requires all arrow panels to be rectangular, of solid construction, finished with non-reflective flat black, and meet the minimum size requirement in accordance with speed and type of facility. Any arrow panel which does not meet one or more of the MUTCD standards is considered to be non-standard. Due to their cost and transportation advantage, non-standard arrow panels have now become as popular on local streets as the large panels are on freeways. The following sections discuss the current practices of states, municipalities, and utility companies in using non-standard arrow panels.

1. **State governments.** The non-standard panels are regarded as illegal traffic control devices when used on state roads. Proliferation of these devices appears to be under control in some states, e.g., California and Pennsylvania. The non-standard arrow panel has been observed on several state-owned vehicles, and its existence cannot be ignored. In most cases, these panels lack a rectangular non-reflective flat black background, have less panel lamps than the minimum requirement, do not have the minimum legibility distance, and are small in size. Figure 24 demonstrates a non-standard arrow panel which possess at least three of the above deficiencies: size, flat black finish, and legibility distance. Although state officials





Figure 24. Non-standard arrow panel on an Interstate highway

discourage the use of non-standard arrow panels on high-speed roads, there are several non-standard arrow panels that are mounted on state vehicles. In fact, discussions with arrow panel suppliers indicate that at least seven state highway agencies are currently using the non-standard arrow panel size of 24 inches x 60 inches on moderate to high-speed (45-55 miles per hour) roadways. Among the applications observed for the non-standard arrow panel are shoulder maintenance, setting up channelizing devices, interchange sweeping, highway litter control, and mobile operations. Cost savings and mobility in work zones appear to be the primary reasons for acquiring non-standard arrow panels.

2. **Municipalities.** Local governments are heavy users of the mini-arrow panel. The mini-arrow panel offers them cost advantages, less labor-intensive operation, accessibility, flexibility, and a traffic control device that is capable of displaying the same modes as some larger standard arrow panels.

The mini-arrow panel was observed mostly on low volume, low speed roads. The mini-arrow panels were mounted above the cab or at the rear of vehicles. Mounting height ranged from five to ten feet. Figures 25 and 26 demonstrate a few field applications. The City of Baltimore, Maryland, owns several mini-arrow panels which are used during litter control and pavement marking operations. The City of Monroe, Michigan uses mini-arrow panels to manage traffic during crosswalk pavement marking operations. The users of the mini-panel in urban areas are utility companies, city traffic departments, city maintenance departments, and contractors.

Proliferation of the mini-arrow panel among city governments is not under control by any means. Cities, contractors, and utility companies are willingly purchasing these devices. Proliferation is greater among cities which do not have an active process for the review and approval of all traffic control devices for work zones. In such cities it is not uncommon for maintenance personnel to order a number of traffic control devices, including non-standard arrow panels, without notifying the traffic engineering division. In at least three large cities, Chicago, Washington, D.C., and New York, the traffic engineering officials were not aware of the extensive use of non-standard arrow panels on local streets. San Francisco, California, is one city that has not allowed non-standard arrow panels to emerge



Figure 25. Use of mini-arrow panels on local streets





Figure 26. Use of mini-arrow panels on local streets

as defacto traffic control devices. Unlike most cities, San Francisco maintains a rigid policy which requires all traffic control devices for work zones to be approved by the traffic engineering division and provides for strict enforcement from the police and a team of trained field inspectors.

3. **Utility companies.** Over the past ten years, the utility companies experience with the mini-arrow panel has changed dramatically. According to a study by Graham et al. (7) in 1978, utility companies did not use arrow panels to conduct their operations. Today, utility companies are acquiring a great number of mini-arrow panels to conduct their daily operations.

The Washington Suburban Sanitary Commission (WSSC) is a heavy user of mini-panels and has acquired at least three brands of mini-arrow panels. Mini-arrow panels now are being used for emergency, short-duration, and long-duration operations when a lane is closed. Observed mini-arrow panel applications by utility companies include water and sanitary structure adjustments and replacements, structure cleaning, and telephone line repair. Few mini-arrow panels were observed on moderate to high-speed arterials.

Due to the lack of local, state and federal policies on the use of the mini-arrow panel, its use has spread to moderate speed (25 - 45 miles per hour) facilities. A mini-arrow panel has been observed in operation on the same construction vehicles as flashing strobe lights. Such use is not yet defined by any of the users, but it is speculated that the mini-arrow panel is usually mounted on trucks that already have the strobe lights. It is not known whether the strobe lights are operated together with the mini-arrow panel.

State and local officials expressed mixed opinions about the mini-arrow panel. The majority of the officials agree that the mini-arrow panel should be standardized in terms of size, readable distance, lamp characteristics, and application requirements. Few officials, however, insist that the MUTCD's smallest standard arrow panel (24 inches x 48 inches) be used in lieu of the mini-panel. The MUTCD's smallest panel can be mounted on the top or rear of vehicles, is capable of displaying equal or greater modes of operation, has dimming and flashing capability, and is the same size or slightly larger than most non-standard arrow panels. Yet, the practice in urban jurisdictions is overwhelmingly



supportive of the mini-panel.

The following summarizes key observations about non-standard arrow-panel practices:

- a. The non-standard arrow panel is generally not allowed in work zones on interstate highways. Proliferation at the state levels appears to be under control.
- b. The 24-inch x 60-inch non-standard arrow panel is currently used by state maintenance forces on moderate to high-speed state roads, including interstate facilities.
- c. State highway officials support the need for mini-arrow panels among local agencies.
- d. The use of non-standard arrow panels among local governments is extensive and is strongly supported by urban officials.
- e. Specifications for the design of non-standard arrow panels are lacking.
- f. Apathy within the urban traffic engineering community has encouraged the proliferation of non-standard arrow panels.
- g. The non-standard arrow panels appear to be effective in some situations. Application guidelines could curb their inappropriate usage.
- h. The mini-arrow panel is currently used on facilities with posted speeds up to 45 miles per hour.
- i. Among the applications for mini-arrow panels are pavement striping, pavement resurfacing, signal maintenance, litter control, and utility work.
- j. Mini-arrow panels are widely used by utility companies.



#### IV. MAINTENANCE AND COST OF ARROW PANELS

The maintenance and cost of arrow panels are essential to their selection and application. While standard trailer and roof-mounted arrow panels can be used to control traffic in highway work zones, their high cost is the primary reason why utility companies and maintenance divisions of local governments have sought inexpensive devices such as the mini-arrow panel.

This section discusses some of the most common maintenance problems that were observed during the field visits and presents the cost of acquiring and maintaining arrow panels.

**A. Maintenance.** Maintenance of arrow panels varies by panel size, mounting equipment, quality of lamps, dimming features, power supply, and placement. For example, trailer-mounted arrow panels require more maintenance than truck-mounted panels.

Two common problems that result from a lack of proper maintenance are inadequate dimmer control and non-uniformity in the brightness of panel lamps. Inadequate dimming of the flashing arrow panel at night was observed at several work sites. Similarly, several state highway officials emphasized this problem and indicated a need for better dimming control features. One state official indicated that of the twenty panels inspected during night operation in his state, more than half of these panels did not meet the state's dimming requirements although all the panels were designed to meet the MUTCD's or the state's criterion on dimming control.

Excessive brightness of the arrow panel can blank out the lane closure features and cause temporarily blindness to motorists. This is perceived to be a very serious problem despite the lack of accident or conflict data to quantify the seriousness and implications of this problem. State officials indicated that such problems are usually corrected once they are detected, but they strongly believe that the panels should be equipped with testing mechanisms to detect these problems prior to usage and during application. The current procedure is very inconvenient and time-consuming; it requires visual inspection at night. Test-points or accommodations for a built-in voltage meter mechanism is currently lacking. According to discussions with arrow panel vendors, these features could be easily designed and implemented. Arrow panels that are currently used could also be rewired to include these provisions. Some arrow panel vendors recognize these problems and agree that a continuing maintenance effort is currently required to assure proper operation of the dimming control unit.

Another problem that was observed and discussed with contractors is the proper installation of replaced lamps. Faulty installation usually causes misorientation of the lamps and non-uniformity in the panel lights. This problem was noticed during both day and night operations. In addition, photocells should always be cleaned, inspected for damage or flaws in the operating electronics, and checked for face position. The lamp hoods also should always be installed unless the lamps are recess-mounted.

**B. Cost of Equipment.** As shown in Table 5, the cost of standard arrow panels varies according to the panel size and mounting type. The trailer-mounted arrow panel is the most expensive of the three types. The average cost of the trailer-mounted and vehicle-mounted (48-inch x 96-inch) arrow panel is \$5,000 (including the cost of the trailer) and \$1,800, respectively. Both types could be rented for an average cost of \$20 and \$15 per day, respectively. The trailer-mounted panel is more expensive to maintain than the other types. The cost of the standard 24-inch x 48-inch arrow panel ranges between \$600 and \$800; its upkeep cost is approximately \$10 per every 1000 hours.

The cost of mini-arrow panels depends on the sophistication and size of the equipment. Due to the lack of uniform specifications, the cost of the mini-panel ranges from \$200 to \$600.

**Table 5. Cost of arrow panels**

Type	Dimension (Inches)	Average Cost
Standard Trailer- Mounted:	30 x 60	\$4500
	48 x 96	\$5000 (e)
Standard Truck- Mounted:	24 x 48	\$ 750
	30 x 54	\$1500
	48 x 96	\$1800
Non-Standard Truck-Mounted:	13 x 55	\$ 210-\$600*
	20.5 x 24	\$ 265**
	21 x 24	\$ 300**
	24 x 60	\$ 595***

- \* Price excludes mounting equipment  
 \*\* Price includes roof-top mounting equipment  
 \*\*\* Price includes mounting equipment and solid state control equipment  
 (e) Includes the cost of the trailer



## V. CONCLUSIONS

1. Past research clearly indicates that the flashing arrow panel is effective in promoting the earlier merging of traffic from the closed lane into the open lanes.
2. Section 6E-7, Part VI of the MUTCD implies that the arrow panel could be used as an optional device. The body of research and practice by the states, however, suggest that the arrow panel is a primary device for lane closures. States are being more descriptive about situations in which arrow panels are specified.
3. State practices imply that the arrow panel is used at all long-duration left and right lane closures on multi-lane divided and undivided highways in urban and rural areas.
4. The need for supplemental arrow panels (a second arrow panel on the shoulder upstream of the taper) in situations where the sight distance -- horizontal or vertical-- is less than 1500 feet is well supported by research (26) and state practices.
5. Placement of the arrow panel on the shoulder immediately behind the channelizing devices appears to be the most common and effective practice. Where the shoulder is narrow or does not exist, the most effective placement of the arrow panel seems to be immediately behind the channelizing devices at the beginning of the taper.
6. A base height of seven to eight feet from ground cover is predominantly used on trailer-mounted and truck-mounted standard arrow panels. State practices and past research strongly support this mounting height. Greater mounting heights are more expensive and not necessarily more effective.
7. Past research indicates that for lane closures the flashing arrow or the sequential chevron are preferred over the sequential arrow.
8. Past research did not find any significant differences between the flashing arrow and the sequential chevron modes. State practices, however, indicate a stronger preference for the flashing arrow mode.
9. Most states are using arrow panels during moving operations.
10. State practices imply that a flashing arrow or sequential chevron should not be used for shoulder closures unless

however, support the use of the caution mode operation when the arrow panels are used for shoulder closures. The use of the caution four-corner flashing mode appears to be on the rise. The caution flashing bar mode is still widely used, however.

11. Officials in eight states offer a mixture of opinions on the use of the flashing arrow panel in the flashing arrow or sequential chevron modes for lane diversion when a lane is not closed. Although these are modes used extensively, some officials argue that such applications are unsafe and weaken the credibility of the arrow panel because the flashing arrow and sequential chevron are perceived by drivers as devices for lane closure rather than lane diversion. This driver misunderstanding was found in laboratory studies conducted by Graham et al. (7). Some officials further believe that arrow panels should not be used routinely for lane diversions, and that their drawbacks should be studied prior to continued use.
12. Standard, large traffic split warning signs (W12-1) have been used behind lane closure barricades to warn drivers of the lane split condition. Recently, the arrow panel with a double arrow flashing mode has been used to supplement the sign and provide advance notice of the split. Most of the highway officials interviewed believe that the flashing double arrow display demands driver concentration and tends to cause confusion.
13. Past research demonstrates a need for multi-arrow panels on multi-lane closures. State practices have also been very supportive of the multi-arrow panel application. One arrow panel is used for each lane closure. The spacing between the two panels remain an issue, especially for urban freeway work sites. The research suggests that the spacing between the panels should be equal to three taper lengths on limited-access freeways. The distance on urban freeways is not documented yet, but state practices imply that the spacing between the two panels should not be less than 1000 feet. Research and state practices support the following placement for multi-arrow panels: the first panel placed on the shoulder at the beginning of the taper, and the second panel placed behind the channelizing devices of the second taper. Placement of a single panel in the middle of the lane closure taper is not supported.
14. The arrow panel specifications presented in Section 6E-9 of the MUTCD are satisfactorily met by states and manufacturers. In fact, several states have strengthened their specifications to improve the quality of the flashing arrow panel and to satisfy their individual needs. The MUTCD lacks specifications on the lamp type,



- lamp spacing, candle power, and power supply. These specifications are widely available from the arrow panel industry and are usually adopted to insure statewide uniformity. The lamp size, for example, is available in 4, 4.5, 5 and 6 inches. Similarly, the power supply to the arrow panel is available in solar, electrical, and gasoline or diesel generators that are capable of energizing the panel lamps for at least 48 hours.
15. Dimming control of the arrow panel is a problem. The nighttime inspection procedure that is currently utilized by all the states visited is very inconvenient and time-consuming.
  16. The MUTCD does not specify the type of fuel for arrow panels. The fuel type is an important issue in addressing the safety and crashworthiness of arrow panels.
  17. The MUTCD defines the arrow panel application as a function of low, intermediate, and high speeds. Stated speed ranges could curb the increasing problem of using non-standard arrow panels on high-speed facilities. A numerical range for low, moderate, and high-speed facilities has already been established in several states for arrow panel applications.
  18. Proliferation of non-standard arrow panels is very apparent, especially in cities and counties.
  19. There are wide variations in the design of non-standard arrow panels. Some manufacturers have recognized the need for the mini-panels to have dimmer and glare control features. Their visual range during bright sun and inclement weather is not known. None of the observed mini-panels meet the MUTCD's standard 24-inch x 48-inch specifications for the rectangular flat black background.
  20. The major difference between the non-standard panel and the standard 24-inch x 48-inch arrow panel is not the size, but the number of lamps, its recognition distance, finished background frame, dimming features, glare elimination, display modes, and cost. The size difference is only in the height of the panel. The mini-arrow panel is generally two to three inches shorter than the smallest standard arrow panel.
  21. Research on the mini-arrow panel has been very limited.
  22. Current guidelines in the MUTCD regarding the use of arrow panels are very limited and do not address their use in work zones on local streets. Future revisions of the MUTCD must provide guidelines on the use of arrow panels on all types of roadways and traffic control situations.



## **VI. RECOMMENDATIONS**

The recommendations presented below are based on a review of the literature and the standards and visits and discussions with highway officials from California, Delaware, Illinois, Maryland, Washington, D.C., Michigan, New York, Ohio, Minnesota, Pennsylvania, and Virginia concerning arrow panel design and use in work zones.

This section is divided into three subsections dealing with arrow panel applications, arrow panel specifications, and further research on arrow panels.

**A. Arrow Panel Applications.** The MUTCD must be explicit about the use of arrow panels. Currently, all illustrations indicate optional use. This must be corrected in view of current knowledge. Text information must utilize the word "shall" as opposed to the current language.

1. The following is a list of lane closure conditions where the arrow panel can enhance work zone safety.
  - a. Multi-lane divided or undivided roadways, when the left or right lane is closed during the daytime and nighttime peak hours for more than four hours. Only left or right arrows must be shown.
  - b. Multi-lane divided or undivided roadways when the left or right lane is closed for nighttime maintenance operations of short duration. Only the left or right arrows must be shown.
  - c. Center lane closures that involve multi-lane closures such as left and center or right and center lanes.
  - d. Center lane closures that require only left or right lane closures preceding the work zone and center lane traffic being diverted either left or right.
  - e. Lane diversions with lane closures.
  - f. At urban intersections with multi-lane approaches when the left, right, or center lane is closed for long durations or during the peak hours.
  - g. For mobile operations on multi-lane highways.





5. A supplemental arrow panel (a second arrow panel placed on the shoulder upstream of the lane closure taper) should be used if the minimum sight distance to the first arrow panel is less than 1,500 feet.
6. For moving-maintenance activities, the arrow panel should be placed at the rear of the activity in the closed lane either on a towed-trailer or on a vehicle separate from the maintenance vehicle itself.
7. For multi-lane closures, two arrow panels should be used; one panel at the beginning of the taper for each lane closure. The minimum spacing between the panels on limited access facilities should not be less than the length of three lane closure tapers.
8. For lane closures where the shoulder is either narrow or does not exist, the arrow panel must be placed immediately behind the channelizing devices at the beginning of the taper.

**B. Arrow Panel Specifications.** Section 6E-9, Part VI of the MUTCD should consider the following issues for further inclusions:

1. The MUTCD should set speed ranges for each type of arrow panel. The low speed range should be zero to 35 miles per hour; the intermediate speed range should be 36 to 45 miles per hour, and the high speed range should be 46 to 55 miles per hour.
2. Requirements for the minimum recognition distance for arrow panels should distinguish between urban and rural areas.
3. Specifications pertaining to the lamp design such as lamp type, candle power, lamp spacing, and size should be incorporated into the MUTCD in an arrow panel illustration. The minimum lamp size could vary between 4 and 5 inches according to the arrow panel size.
4. The minimum mounting height from ground level to the panel base should not be less than 7 feet regardless of the mounting apparatus and type of arrow panel.
5. The arrow panel lamps should be equipped with an automatic photovoltaic dimming switch which controls the light intensity of all lamps. Activation should be at a level of approximately two to five candellas. The solar cell should be equipped with a time delay to prevent false actuation from flashlights. The dimming voltage to the lamps should be manually



controllable over a 5 to 12 volt effective range. The arrow panel should also be equipped with either test-points for voltmeter readings or a built-in voltmeter to examine the voltage level for proper dimming operation.

6. Arrow panels should be powered by self-contained engine-driven generator systems capable of energizing the panel lamps for at least 48 hours. Gasoline generators should not be allowed due to potential safety problems.

**C. Further Research on Arrow Panels.**

1. There is a need to re-examine the role of the arrow panel as a supplementary device to advance warning signs for lane closures. Motorist understanding of the arrow panel, positive driver response to arrow panels, and its high target value and increased visibility suggest that the arrow panel may be the primary information source.
2. There is a need to examine the relative effectiveness of the flashing arrow and sequential chevron modes of operation for lane closures.
3. Additional research is needed to determine the best caution mode of operation (flashing four-corners versus flashing bar) for shoulder work and lane closures on two-lane, two-way highways.
4. Additional research is needed to determine the most effective arrow panel mode and the best combination of traffic control devices for lane diversions. There is concern that use of a flashing arrow or sequential chevron for lane diversions without lane closure confuses drivers and results in unnecessary lane changes. Some states are now using a caution mode of operation for lane diversions. Research is also needed to determine the most effective placement and positioning of the arrow panel.
5. Research is needed to determine the crashworthiness of trailer-mounted arrow panels in order to improve their physical safety features.
6. The MUTCD should provide guidelines on the most effective traffic control and arrow panel applications for lane splits.
7. The MUTCD should provide guidelines on the use of a supplemental arrow panel (a second arrow panel located on the shoulder upstream of the taper) when

sight distance to the lane closure is restricted (less than 1500 feet) as commonly experienced in urban areas.

8. Research is needed to evaluate the mini-panel for use on urban arterials and streets. Research is particularly critical because of the proliferation of several non-standard arrow panels. The research should include several types of applications such as daytime and nighttime, long-term and short-term, emergency operations, utility maintenance, etc. In addition, characteristics such as flashing rates, dimming, modes, number and size of lamps, lamp visors, etc. should be examined.
9. The MUTCD should include guidelines for the use of arrow panels by municipalities and utility companies on urban arterials and streets.

## LIST OF REFERENCES

1. U. S. Department of Transportation, Manual on Uniform Traffic Control Devices, Washington, D.C., July, 1978.
2. McGee, H. W. et al. "Chapter 10. Construction and Maintenance Zones," Synthesis of Safety Research Related to Traffic Control and Roadway Elements, Volume 2, Report No. FHWA-TS-82-233, Federal Highway Administration, Washington, D.C., December 1982.
3. McGee, H. W. and B.G. Knapp, "Visibility Requirements of Work Zone Traffic Control Devices," Report No. FHWA-RD-78-143, Federal Highway Administration, July, 1978.
4. Richards, S. H. Wunderlich, R. C. and Dudek, C. L., "Field Evaluation of Work Zone Speed Control Techniques," Transportation Research Record No. 1035, Transportation Research Board, Washington, D.C., 1985.
5. Richards, S. H., Wunderlich, R. C., Dudek, C. L. and Brackett, R. Q., Improved and New Concepts for Traffic Control in Work Zones, Vol. 4 - Speed Control in Work Zones, Report No. FHWA-RD-85-037, Texas Transportation Institute, College Station, Texas, September, 1985.
6. Faulkner, M. J. S. and Dudek, C. L., "Flashing Arrowboards in Advance of Freeway Work Zones," Transportation Research Record No. 864, Transportation Research Board, Washington, D.C., 1982.
7. Graham, Jerry L., Migletz, Donald J., and Glennon, J. C., Guidelines for the Application of Arrow Boards in Work Zones, Final Report. Report No. FHWA-RD-79-58, Federal Highway Administration, Washington, D.C., 1978.
8. McAllister, J. J. and Kramer, D. L., Advance Warning Arrow Sign Study, California Department of Transportation, 1974.
9. Pain, R. F., Hanscom, F. R., and McGee, H. W., Work-Site "Traffic Controls in the U.S. Existing and New Technologies," Traffic Engineering and Control, Vol. 24, No. 10, Prentice Hall, October 1983.
10. U.S. Department of Transportation, Traffic Control Devices Handbook, Federal Highway Administration, Washington, D.C., 1983.
11. Bryden, J. E., "Effectiveness of Flashing Arrow Boards During Moving Maintenance Operations," Report No. FHWA/NY/RR-79/73, New York Department of Transportation, October 1979.



12. Dudek, C. L. and Richards, S., Planning and Implementing Work Zone Traffic Control - Student Notebook, Texas State Department of Highways and Public Transportation, (no date).
13. Bates, L., The Effect of Arrow Board Trucks on Merging Traffic, Illinois Department of Transportation, July 1974.
14. Shah, S. C. and Ray, G. L., Advance Traffic Control Warning Systems for Maintenance Operations, Report No. 105, Louisiana Department of Highways, July 1976.
15. Graham, J. L., Pulsen, R. J. and Glennon, J. C., Accident and Speed Studies in Construction Zones, Report No. FHWA-RD-77-80, Federal Highway Administration, Washington, D.C., June 1977.
16. Dudek, C. L., Richards, S. H. and Faulkner, M. J. S., Feasibility of Changeable Message Signs and Highway Advisory Radio for Freeway Maintenance, Report No. FHWA/TX-81/43-228-9, Texas Transportation Research Board, Washington, D.C., 1982.
17. Michigan Department of Transportation, Michigan Manual of Uniform Traffic Control Devices, Part VI, Construction and Maintenance, Lansing, Michigan, January 1987.
18. Virginia Department of Transportation, Virginia Work Area Protection Manual, Standards and Guidelines, Richmond, Virginia, January 1987.
19. California Department of Transportation, State of California Manual of Traffic Controls for Construction and Maintenance Work Zones, Sacramento, California, 1985.
20. Delaware Department of Transportation, Traffic Control for Streets and Highway Construction and Maintenance Operations, Dover, Delaware, January 1984.
21. Illinois Department of Transportation, Illinois Manual of Uniform Traffic Control Devices, Springfield, Illinois, April 1987.
22. Pennsylvania Department of Transportation, Work Zone Traffic Control, Publication No. 203, Harrisburg, Pennsylvania, August 1984.
23. Ohio Department of Transportation, Ohio Manual on Uniform Traffic Control Devices, Columbus, Ohio, 1982.
24. Maryland Department of Transportation, Construction Traffic Control Plans Manual, Glen Burnie, Maryland, April 1985.

25. New York Department of Transportation, New York Manual of Uniform Traffic Control Devices, Albany, New York, 1983.
26. Faulkner, M. J. S., and Dudek, C. L., Field Evaluation of Flashing Arrowboards at Freeway Work Zones, Report FHWA/TX-82/13-228-5, Texas Transportation Institute, College Station, Texas, April 1981.
27. "A Policy on Geometric Design of Highways and Streets," American Association of State Highway and Transportation Officials, 1984.
28. Alexander, G. J. and Lunenfeld, H., "Positive Guidance in Traffic Control," U. S. Department of Transportation, Federal Highway Administration, 1975.
29. Knapp, B. G. and Pain, R.F., "Human Factors Considerations in Arrow Board Design and Operation," BioTechnology Inc., Falls Church, Virginia, July 1978.
30. Dudek, C. L. and Ullman, G. L., "Traffic Control for Short Duration Maintenance Operations on Four-Lane Divided Highways," Paper presented at the Annual Meeting of the Transportation Research Board. January 1989.
31. S. H. Richards and C. L. Dudek, "Field Evaluation of Traffic Management Strategies for Maintenance Operations on Freeway Middle Lanes," Transportation Research Record 703, 1979.
32. Hostetter, R. s., Crowely, K. W., Dauber, G. W., Pollack, L. E., and Levin, S., "Determination of Driver Needs in Work Zones," Report No. FHWA/RD-82/117, Federal Highway Administration, September 1982.

