



U.S. Department
of Transportation

**Federal Highway
Administration**

Publication No. FHWA-TS-89-036
July 1989

Work Zone Traffic Management Synthesis:

Tiedown Methods For Precast Concrete Safety Shaped Barriers

Research, Development, and Technology
Turner-Fairbank Highway Research Center
6300 Georgetown Pike
McLean, Virginia 22101-2296

NOTICE

This document is disseminated under the sponsorship of the Department of Transportation in the interest of information exchange. The United States Government assumes no liability for its contents or use thereof.

The contents of this report reflect the views of the contractors who are responsible for the facts and the accuracy of the data presented herein. The contents do not necessarily reflect the official views or policy of the Department of Transportation.

This report does not constitute a standard specification, or regulation.

The United States Government does not endorse products or manufacturers. Trademarks or manufacturers' names appear herein only because they are considered essential to the object of this document.

1. Report No. FHWA-TS-89-036		2. Government Accession No.		3. Recipient's Catalog No.	
4. Title and Subtitle Work Zone Traffic Management Synthesis: Tiedown Methods for Precast Concrete Safety Shaped Barriers				5. Report Date July 1989	
				6. Performing Organization Code	
7. Author(s) Errol C. Noel, Ziad A. Sabra, Conrad L. Dudek				8. Performing Organization Report No.	
9. Performing Organization Name and Address Contractor: Daniel Consultants, Inc. Columbia, Maryland Subcontractor: Dudek & Assoc., Bryan, Texas				10. Work Unit No. (TRIS) NCP 3A9a 0073	
				11. Contract or Grant No. DTFH61-88-X-00007	
12. Sponsoring Agency Name and Address Federal Highway Administration Turner-Fairbank Highway Research Center 6300 Georgetwon Pike McLean, Virginia 22101-2296				13. Type of Report and Period Covered Final Report May 1988 - May 1989	
				14. Sponsoring Agency Code	
15. Supplementary Notes FHWA Contract Manager: Guenther Lerch, HRT-20					
16. Abstract <p>This report is a synthesis of research findings and current practices regarding the design and application of systems for anchoring (tying down) portable concrete safety shaped barriers (CSSBs) to highway pavements. The presented information is based on a literature review, field observation and discussions with highway officials in a selection of states. The report presents design graphics on a number of methods for controlling sliding, tilting and overturning of portable CSSBs, identifies areas for research, and makes recommendation regarding practices and information that should be included in the AASHTO <u>Roadside Design Guide</u>.</p>					
17. Key Words barrier tiedown, barrier anchorage concrete barrier, work zone safety			18. Distribution Statement No restrictions. This document is available to the public through the National Technical Information Service, Springfield, VA 22161		
19. Security Classif. (of this report) Unclassified		20. Security Classif. (of this page) Unclassified		21. No. of Pages 67	22. Price

TABLE OF CONTENTS

	Page
I. INTRODUCTION	1
II. RESEARCH FINDINGS ON PORTABLE CSSB	6
III. CURRENT PRACTICES	18
A. Need for Vertical Anchorage	18
B. Application and Design of Anchorage Systems in Selected States	18
IV. ASSESSMENT OF RESEARCH AND PRACTICES	45
V. CONCLUSIONS	48
VI. RECOMMENDATIONS	49
LIST OF REFERENCES	50
APPENDIX	52

LIST OF FIGURES

	Page
Figure 1. Portable concrete safety shaped barrier	2
Figure 2. General categories of connectors for portable safety concrete barriers	4
Figure 3. Hybrid connector system	5
Figure 4. Use of slip plates to reduce lateral displacement	7
Figure 5. New York's H-Pin connector	9
Figure 6. New York pin and dowel vertical anchorage ...	10
Figure 7. Tongue and groove and side plate test connector system	12
Figure 8. Texas T-lock connector design	13
Figure 9. Anchor plates, studs and bolts	15
Figure 10. Driven anchor plates	16
Figure 11. Barrier anchorage determination procedure of Ohio	22
Figure 12. Anchors required per 10-foot barrier segment for Ohio's modified-existing barrier chains	23
Figure 13. Anchors required per 10-foot barrier segment for Ohio's proposed barrier chains	24
Figure 14. Impact severity versus roadway width	25
Figure 15. Placement versus impact severity of unanchored barrier chains composed of 10-foot long segments	26
Figure 16. Partial details of Ohio's proposed anchorage of portable CSSBs on bridge decks	27
Figure 17. Ohio's proposed design for pin and loop connectors	28
Figure 18. Anchorage with dowel bolt, nut, and washer	29
Figure 19. Protecting workers with anchored barriers ...	30
Figure 20. Maryland's method for anchoring portable CSSBs	32
Figure 21. Location of anchoring system on Maryland's portable CSSB	33
Figure 22. Connector details for Maryland's vertical anchoring system	34
Figure 23. Installed vertical anchoring system in Maryland	35
Figure 24. Virginia's use of anchor bolts	36
Figure 25. Characteristics of CSSB anchorage in California	38
Figure 26. Partial detail of New York's system for anchoring portable CSSBs	39
Figure 27. Barriers anchored with dowel pins in Illinois	41

Figure 28.	Placement of anchor bolts on New Jersey's Type-1 barrier	42
Figure 29.	Design of New Jersey's barrier anchoring system	43
Figure 30.	Partial detail of Florida's vertical anchorage for portable CSSBs	44

LIST OF TABLES

Table 1.	Results of impact tests on barrier anchorage ...	17
Table 2.	Connectors and displacement control methods	19
Table 3.	Connectors and displacement control methods (Table 2. continued)	20

I. INTRODUCTION

The information presented in this report is based on a literature review, field observations, and discussions with highway officials in Pennsylvania, Virginia, Maryland, Illinois, New York, California, and Washington, D.C., and on material provided by highway officials from New Jersey, Florida, and Ohio.

The concept of using concrete barriers to restrain errant vehicles from penetrating the median and to redirect them while minimizing damage to vehicles and occupants was initiated in Louisiana in 1942. California implemented concrete barriers in 1946 as permanent median installations (1). The basic design of the portable concrete safety shaped barriers (CSSBs) used today is the result of those experiences in Louisiana and California and the quest of New Jersey highway officials for a median barrier with optimum performance characteristics. The name "New Jersey barrier" is associated with the early experimental work on median CSSBs conducted by the New Jersey Department of Transportation. The dimensional characteristics of the New Jersey portable CSSB, shown in Figure 1, have been adopted by most States. It is 32 inches high and has a two-foot base and a six-inch top. Its lower and upper faces are sloped at 55 degrees and 84 degrees respectively from the horizontal plane. The curb edge is about three-inches high.

Early applications of portable CSSBs in work zones involved 15 to 30-foot segments without connectors and anchorage. Their lengths were guided by the need for commercial sizes and the importance of their mass in restricting movement when impacted. Today, barriers range in length from 3 to 30 feet, have linear densities ranging from 450-550 pounds per foot, and are routinely interconnected in field installations. Increasingly, portable CSSBs are being used to keep vehicle and pedestrian traffic from entering work areas; this protects workers, separates two-way traffic, and protects construction equipment at highway work sites.

From the mid-1970s to mid-1980s several crash testing experiments were conducted by the California Department of Transportation (11, 12), the Texas Transportation Institute (4, 5, 6), and the Southwest Research Institute (2, 3) to evaluate the physical characteristics of different portable unanchored CSSBs, their effectiveness in redirecting vehicles and minimizing occupant injuries, and the behavior of their connector systems. During this period, a number of barrier and connector systems evolved as highway officials became aware that barriers could gain increased stability in shear, torsion, tension, and moment by using interconnecting devices. Ivey (7) in 1980, commenting on the state of portable concrete barrier

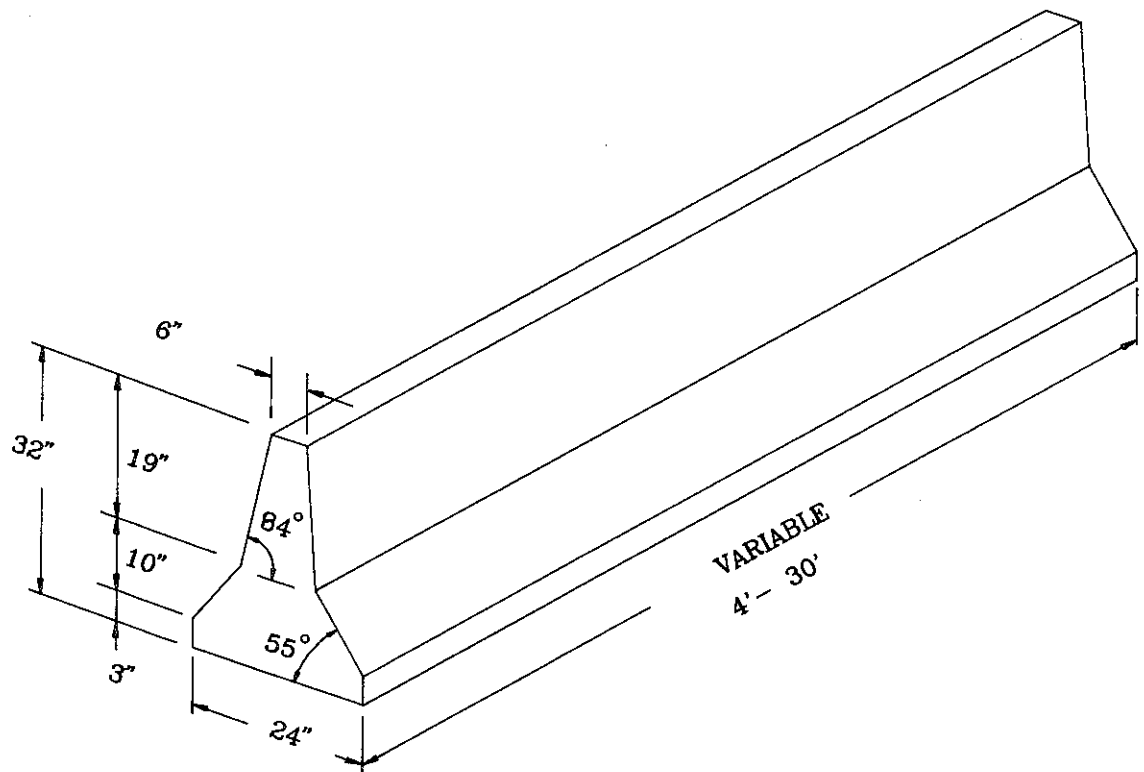

n' = n feet
 n'' = n inches

Figure 1. Portable concrete safety shaped barrier

(PCB) designs, stated: "there are at least as many variations in PCB design as there are states in which it is used." Graham et al. (8) observed in 1987 that there were more than 24 connector designs for portable CSSBs. The April 1988 issue of the ITE Journal (9) grouped connectors into six categories: (a) pin and loop, (b) tongue-and-groove, (c) plate insert, (d) channel splice, (e) double dowel, and (f) I-beam. Schematics of these groups are presented in Figure 2. Each connector group has advantages and disadvantages which are discussed later in this report under the title of Research Findings On Portable CCSBs. As observed by Graham, et al. (33), several subclassifications and hybrid systems have resulted from combining the design characteristics of two or more categories. Figure 3 illustrates one hybrid connector which integrates the features of the tongue-and-groove, channel splice, and double dowel designs. Those interested in details pertaining to the diversity of barrier connectors used for research and in practice are encouraged to review references Nos. 8, 9, and 10. The following section presents research findings on certain connectors; it examines their performance and indicates circumstances when additional stability by vertical anchorage may be warranted.

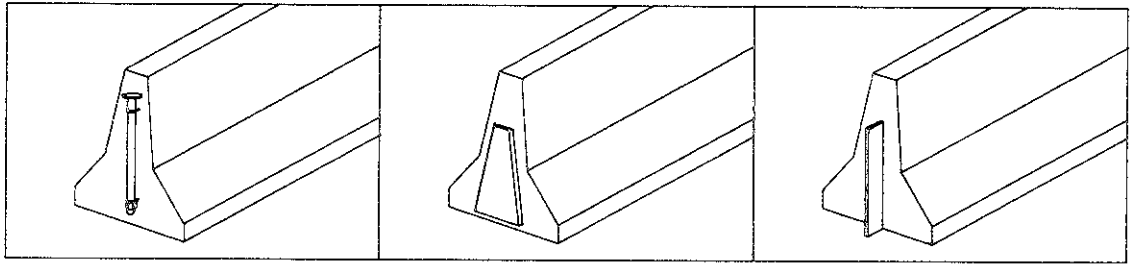

Pin and Loop

Tongue-and-Groove

Plate Insert

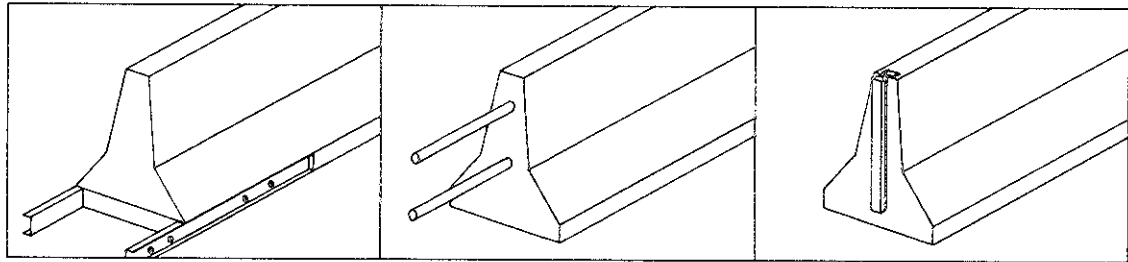

Channel Splice

Double Dowel

I-Beam

Source: (9)

Figure 2. General categories of connectors for portable safety shaped concrete barriers

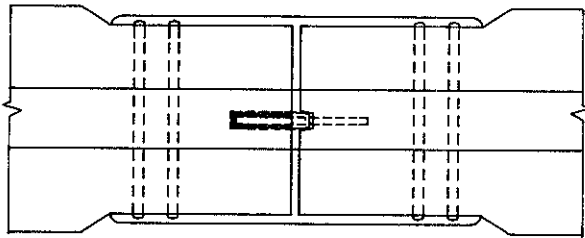

Typical Panel with a View of Connection Detail

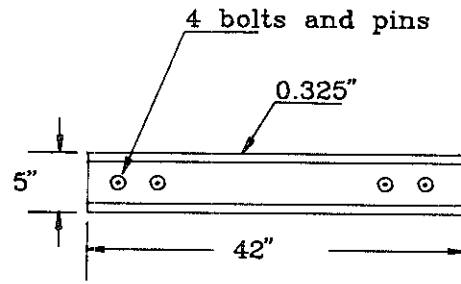
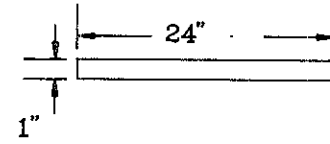

Channel Splice

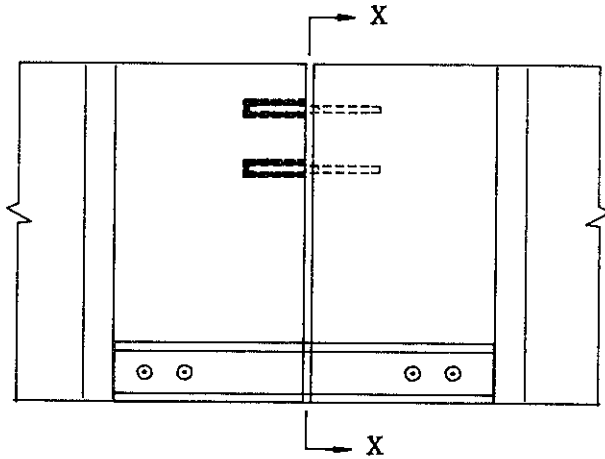

Typical Panel Elevation with a View of Connection Detail

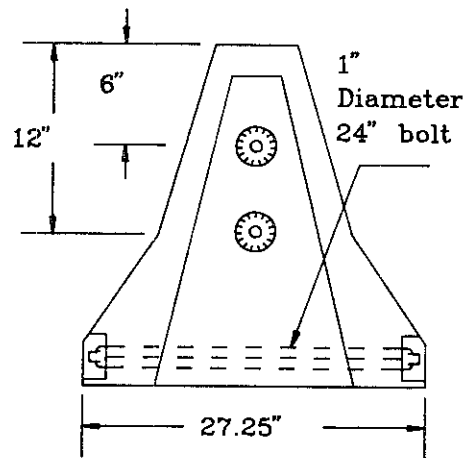

View X-X

Source: (33)

Figure 3. Hybrid connector System

II. RESEARCH FINDINGS ON PORTABLE CSSB

Between 1972 and 1985, the State of California, and the State of New York, the Southwest Research Institute, and the Texas Transportation Institute conducted a number of tests on portable CSSBs. None of these tests were specifically intended for the evaluation or establishment of design standards for vertical anchoring systems which attach portable CSSBs to roadway pavements or pavement attachments for restricting lateral movement. However, the behavior of portable CSSBs and vehicles during some of those tests has triggered concerns about the need for vertical anchoring systems to supplement horizontal connector systems. As used here, anchorage refers to the use of devices for fastening the portable CSSB to the pavement or ground and/or devices that can be attached to the ground or pavement to restrict lateral displacement. Numerous topical reports were reviewed for their insights on vertical anchorage.

In 1976, the California Department of Transportation conducted full-scale impact tests (11) on two freestanding segments of portable CSSBs of 12.5 and 20 feet with pinned end connectors. The barrier sections were 150 feet long and were impacted with full-size cars weighing about 4800 lbs and traveling at speeds between 39 and 65 m.p.h. The impact angles ranged from 7 to 25 degrees. In two of the four tests, the barriers moved laterally. In one test, where the angle of impact was 40 degrees and vehicle speed was 65.5 m.p.h., the barrier rotated excessively causing vehicle vaulting. In one low-speed (25 m.p.h.) impact at 25 degrees, barrier lateral translation of 8.5 feet was observed. Tests conducted by the Southwest Research Institute (3) in 1976 also indicated the susceptibility of unanchored portable CSSBs with tongue and groove and slip plate connectors to shift laterally during 25-degree impacts by 4500-lb vehicles. Subsequent research conducted by the California Department of Transportation in 1977 (12) concluded that there may be situations or site conditions where horizontal connectors should be supplemented with vertical anchorage to restrict lateral translation. Dowel pins for anchoring portable barriers to roadway pavement were advanced for consideration. The California Department of Transportation did not offer any dimensions, material or strength characteristics of such pins.

In 1977, Lisle and Hargroves (13) studied accident characteristics and driver behavior along installations of portable CSSBs during the widening of Route 44 in Virginia. The barriers utilized tongue and groove horizontal connectors. On bridges, two 4-inch x 5.4-inch x 1-foot steel slip plates (see Figure 4) were anchored in the pavement within the barrier keyway and were located 2 feet from each end. The slip plates

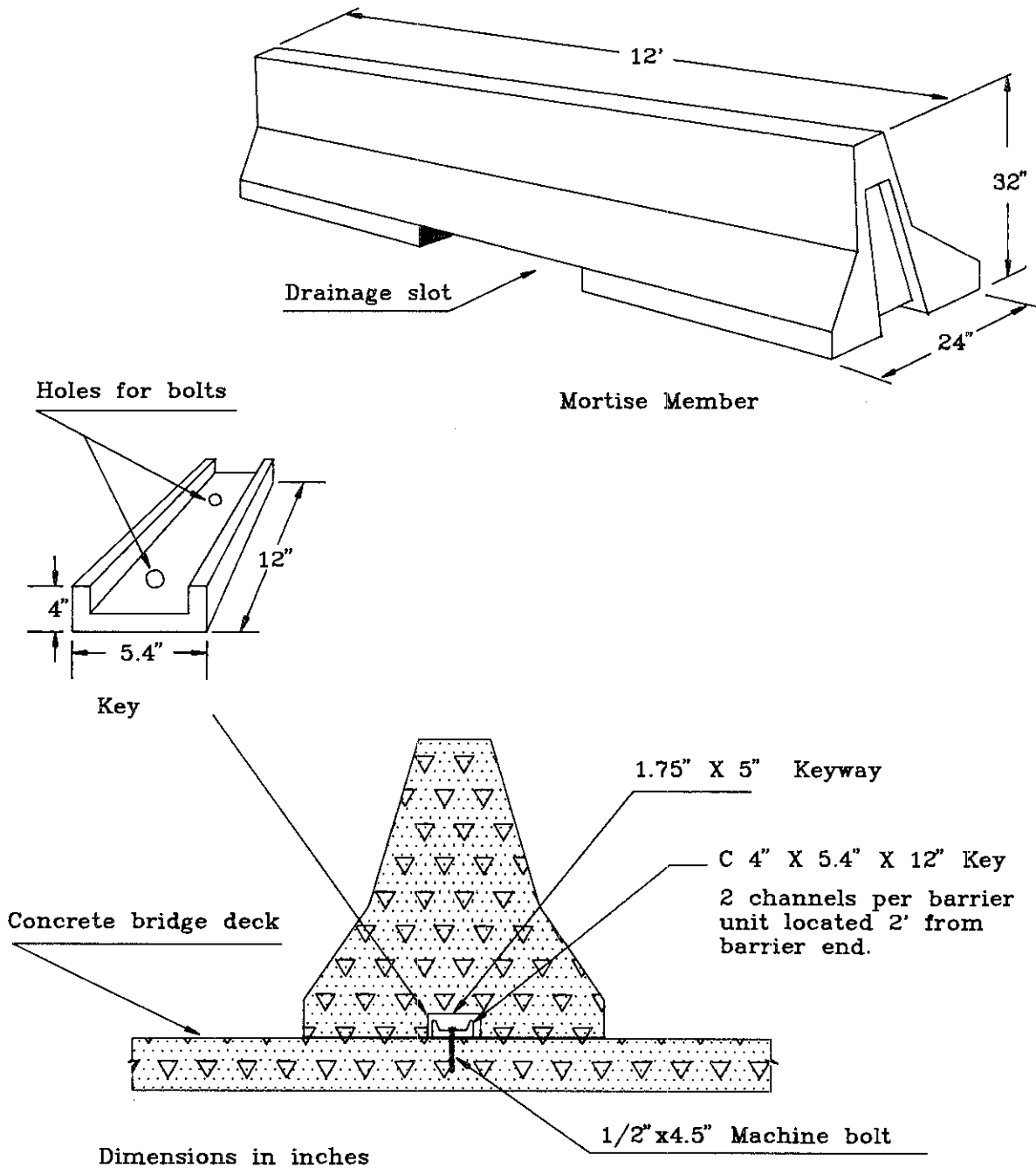

Source: (18)

Figure 4. Use of slip plates to reduce lateral displacement

were intended to prevent lateral movement of the portable CSSBs. Of the ten accidents which occurred during the study, five vehicles infringed on or crossed the adjacent lanes and five remained in the lane next to the barrier. Two of the ten vehicles were involved in wide angle impacts -- greater than 15 degrees -- and rolled over. The authors made no comments regarding the performance of the slip plates in restraining lateral movement.

In 1978, Hahn and Bryden (14, 15) crash tested two sections of the New York portable CSSB. Individual barriers were 20 feet long. Barrier connectors were of the H-pin design indicated in Figure 5. Both tests involved large cars weighing 4230-4250 lbs. which crashed into the barriers at 25 degree angles at speeds of 52.8 and 54.8 m.p.h. The length of barrier sections were 160 feet. Adjoining barriers in the first test were not vertically anchored nor were the joints grouted. In the second test, the barriers were placed in tension to remove joint slack, the upstream end was anchored to the ground with dowel pins -- 1 inch in diameter and 4 feet 8 inches long -- to simulate the resistance due to an upstream end terminus, and mortar was used to grout the joints, thus adding stiffness to the barrier section. Hahn and Bryden concluded that the New York portable CSSB is an effective positive barrier for impacts up to 60 m.p.h. and angles up to 25 degrees and that satisfactory vehicle redirection cannot be assured for impact angles greater than 15 degrees. An important conclusion was that the New York portable CSSB design does not require vertical anchorage to the pavement or the placement of asphalt wedges behind them to provide additional resistance due to severe impacts. Pulling and grouting limited the lateral displacement to 15 inches during the tests conducted by Hahn and Bryden.

In search of a more convenient length of portable CSSB, the New York Department of Transportation in 1980 developed and crash tested eight-foot segments which utilized H-pin connectors (16). The test sections consisted of 20 segments of eight-foot barriers (160 feet long) placed in a straight line. The first and last segments were anchored to the pavement with three 1-inch steel rods driven into the pavement through dowel holes in the barriers. Figure 6 shows the pin and dowel design for this vertical anchorage. The anchorage of the end segments was intended to simulate the resistance due to standard end terminals which were not used in the tests. Further, the stability of the vertical anchorage was not under investigation. Four full-scale crash tests were conducted with 2250 and 4500-pound sedans which impacted the barriers at 60 m.p.h. and at angles ranging from 15 to 25 degrees. Two of the tests utilized grouted joints, and one of the remaining two utilized two smooth-faced 20-foot segments in the impact zone. The authors of the report (16) made the following conclusions:

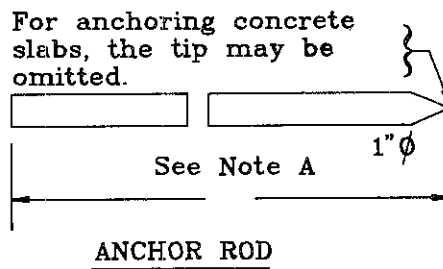
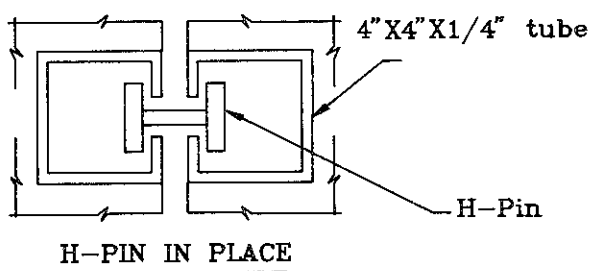
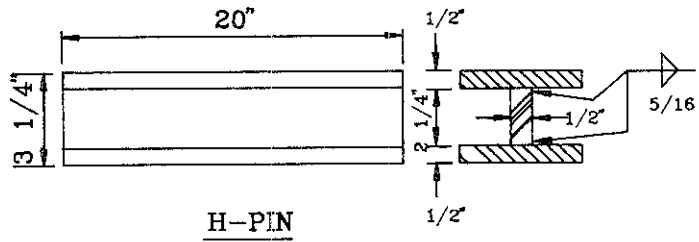
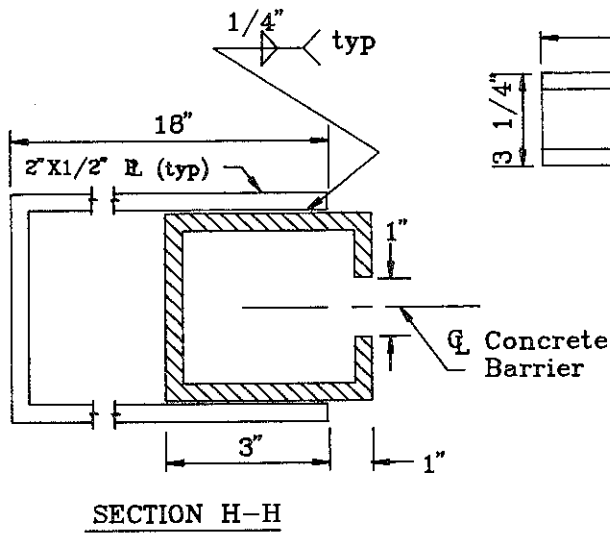
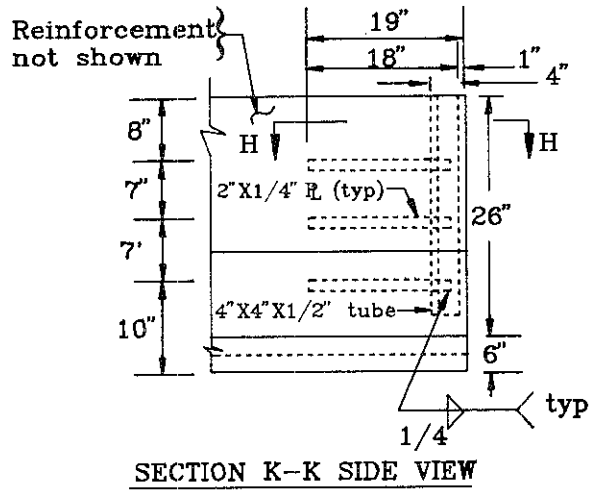
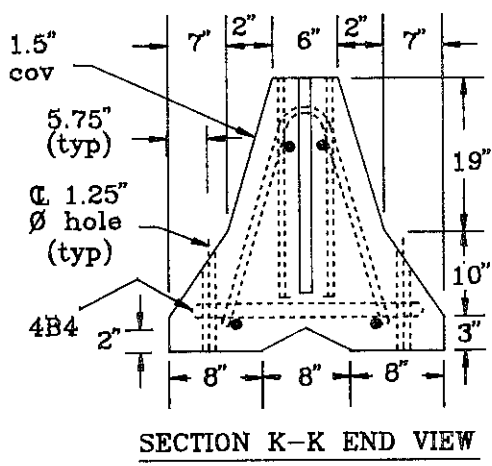

Source: (2)

Figure 5. New York's H-pin connector

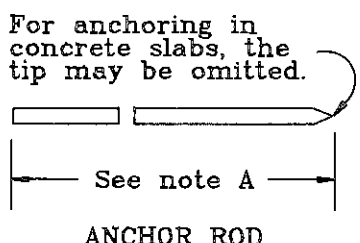
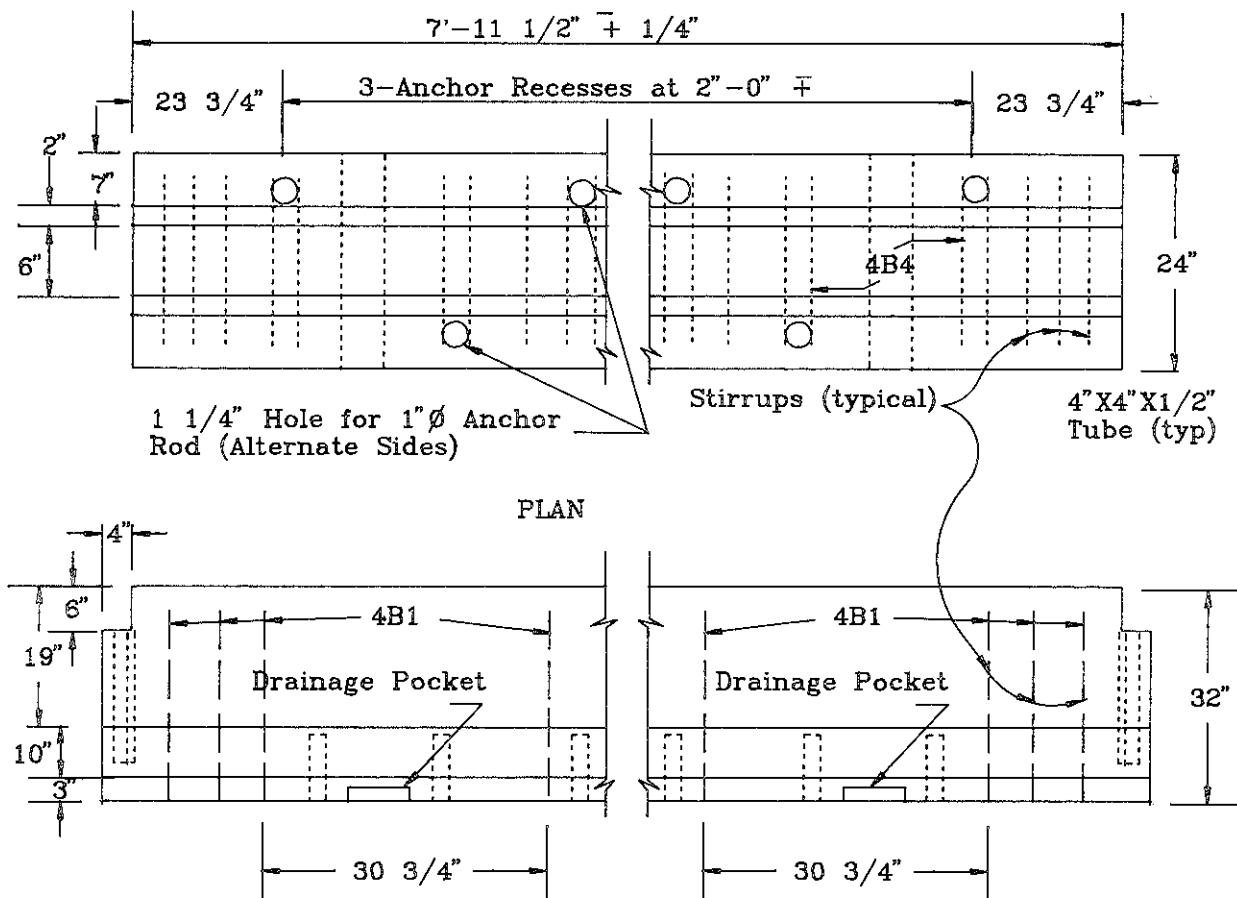

NOTE A

The length of the anchor rods shall be such that the following minimum embedment lengths are obtained:

- (a) Into bridge decks and portland cement concrete pavements 0' - 5"
- (b) Into flexible pavement 1' - 6"
- (c) Into unpaved area 2' - 6"

When anchor rods are in place, they shall not project above the plane of the concrete surface of the barrier.
 Holes in bridge decks shall be 1 1/2" ϕ maximum and made with a core drill or any other approved rotary drilling device that does not impart an impact force.

Source: State of New York Department of Transportation.
 Standard Drawing 619-3R3

Figure 6. New York pin and dowel vertical anchorage

1. Portable CSSBs meeting New York's design standards and using 8-foot segment lengths provided comparable performance with 20-foot segments.
2. New York's H-pin connector system was effective in restraining and redirecting 4500-lb vehicles impacting the barriers at 60 m.p.h. and 25 degrees, although smooth redirection of impacting vehicles cannot be assured.
3. Lateral barrier deflections for 8-foot segments were similar to those of the 20-foot segments, so that the same design deflections can be used for any segment length between 8 and 20 feet.
4. Barrier deflections and corner damages were reduced by pulling the joints tight and grouting the lower six inches of each joint from the front to the rear.
5. Anchoring intermediate barrier segments to the pavement is not necessary unless very small lateral translations are required. The grouted barriers experienced a maximum lateral displacement of 6.75 feet.

In 1985, the Texas Transportation Institute (TTI) reported the results of field testing of a number of portable CSSB sections (4, 5, 6, 7). The tests utilized the tongue and groove barrier connector supplemented with steel plates attached to both sides at the base of the barrier junctions. The barrier design is presented in Figure 7. The barrier installations were 120 feet long. The barriers were unanchored to the pavement, and segments were 12 feet. Test vehicles weighing approximately 4500 lbs. impacted the barriers at 25-degree angles and at 60 m.p.h. The results (4) of four crash tests indicated a maximum permanent deflection of 1.8 feet.

Another series of tests conducted by TTI (6) examined the performance of barriers when impacted by utility-type vehicles: a single-unit truck, five pickup trucks, and two small vans. The test barrier involved the T-lock design illustrated in Figure 8. Segment lengths were 12 feet, and the installed sections were 120 feet long. The impact speed averaged 60 m.p.h., but the angles of impact were relatively flat varying between 6 and 15 degrees. None of the barrier segments were anchored to the pavement. Test results indicated a maximum displacement of 0.63 foot. This low displacement was attributed to the performance of the T-lock connectors as well as the flat impact angles. The extent of displacement at a 25-degree impact angle was not examined in the series of tests.

As part of TTI's barrier safety program, Ivey et al (5) analyzed the strength of various connectors for portable CSSBs.

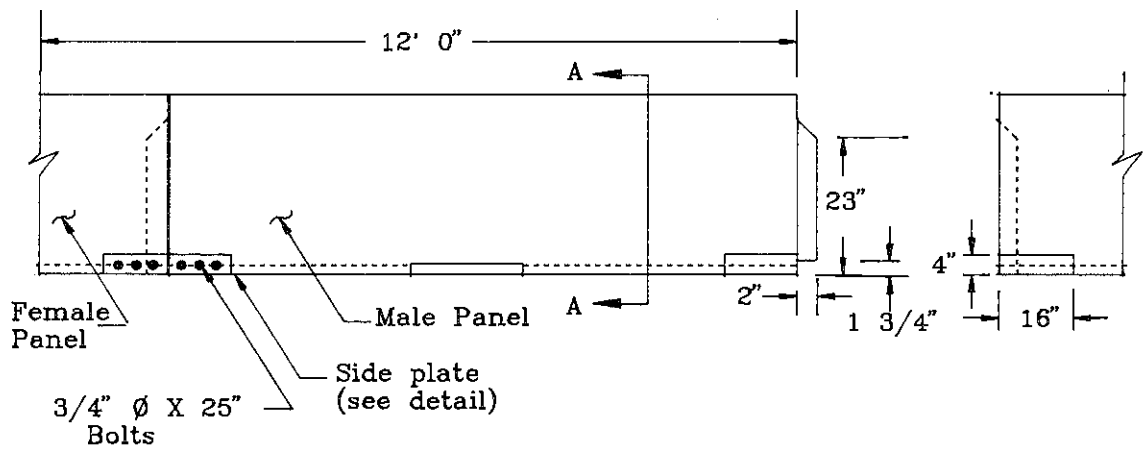

ELEVATION

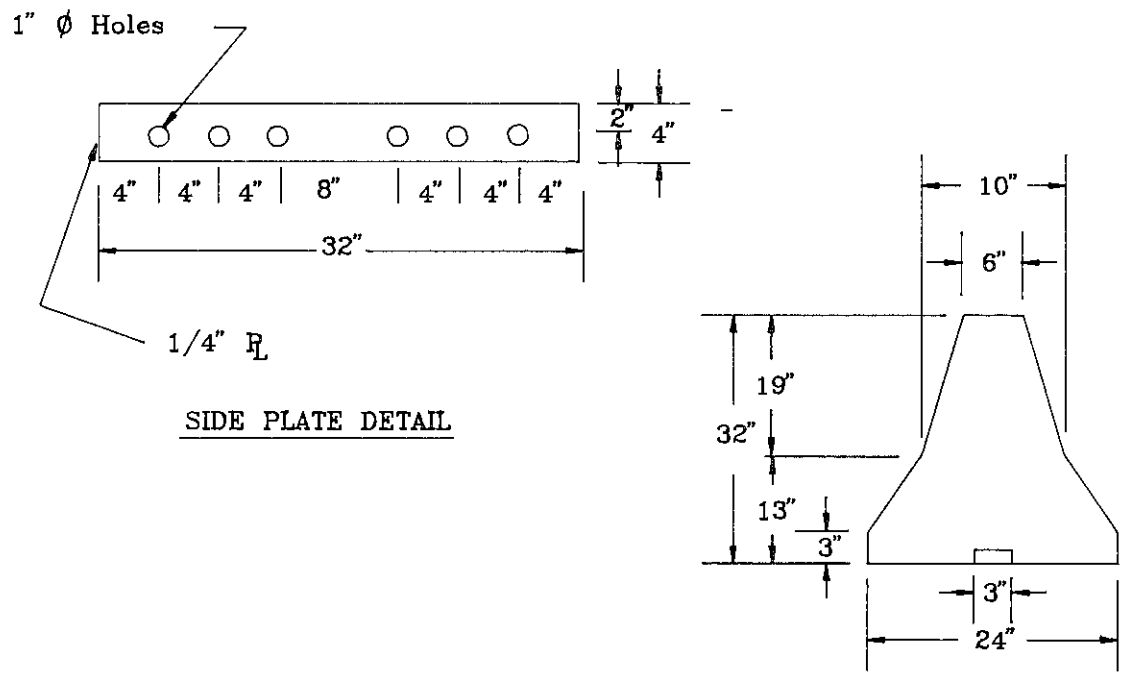

SIDE PLATE DETAIL

SECTION A-A

Source: (11)

Figure 7. Tongue and groove and side plate test connector system

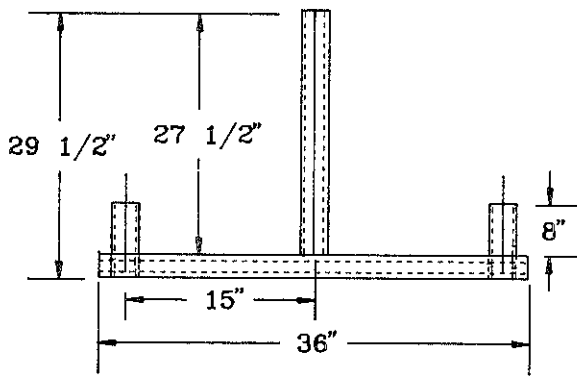

ELEVATOR

STEEL CONNECTOR DETAIL

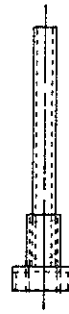

SIDE

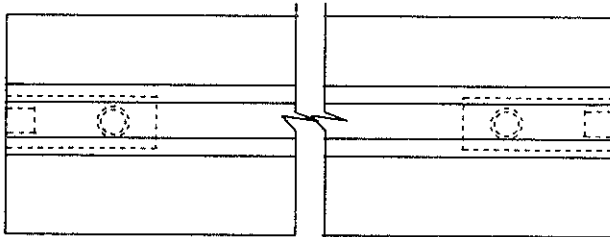

TYPICAL PANEL PLAN

Formed tapered box
 6 1/2" wide-top
 7" wide-bottom
 4 1/2" deep, 18.5" long

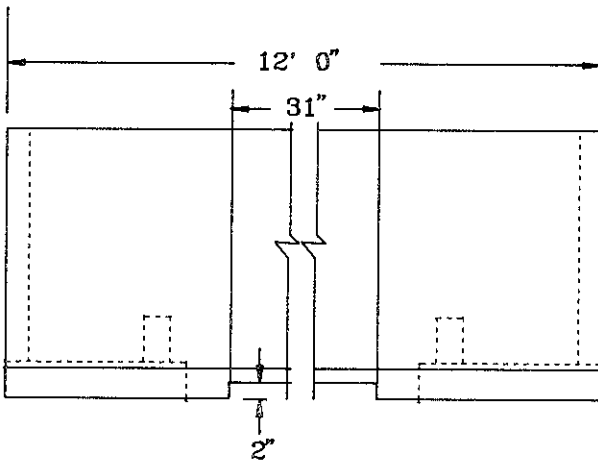

TYPICAL PANEL ELEVATION

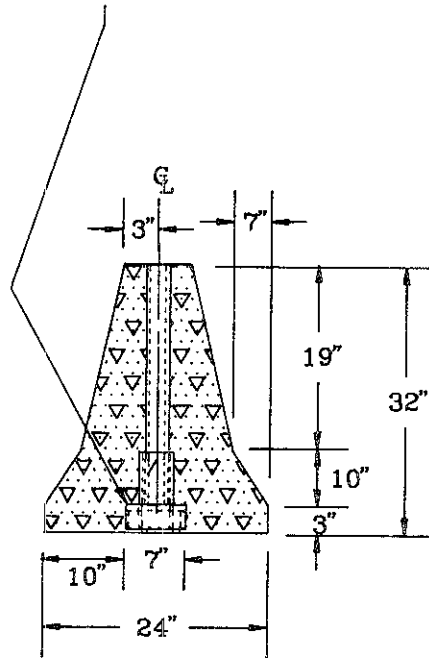

END VIEW

Source: (14)

Figure 8. Texas T-Lock connector design

Of relevance to vertical anchorage was their discussion on the occasional unavailability of space for deflection behind portable CSSBs. The authors noted that the lack of displacement space would require portable CSSBs to function like permanent barriers and suggested that anchoring barriers to their contact surfaces might be appropriate, but their design must be consistent with the expected intensity of the vehicle impact. The authors cautioned against routine use of rigid ground connectors on portable CSSBs and stated that the need for very small deflections should be a rare occurrence where large vertical drop, high speeds, and large angles of impact are anticipated, and the roadwork is expected to last more than a month. Ivey et al. made reference to California's moderate approach which involves vertical anchorage with two one-inch diameter steel rods driven three feet into the soil or base at each segment end. The authors conducted simulated crash tests on three deflection-control devices attached to 12-foot barriers with tongue-and-groove connectors without stabilizing slip plates. The devices were 4-inch x 4-inch x 0.5-inch steel angle plates connected to the concrete pavement with driven studs (see Figure 9) or anchor bolts and 0.25-inch thick triangular steel plates (see Figure 10) driven into the soil against the base of the barriers. The simulated impacts were performed with a 5000-lb. bougie which impacted the barrier at 20 m.p.h. and 90 degrees. As indicated in Table 1, in each case barrier segments rotated or the studs and anchor bolts failed.

None of the literature reviewed supports routine use of vertical anchoring systems. None of the reports presents a clear and convincing case against the need for the vertical anchorage of portable CSSBs when used in long-term work zones on bridges where displacement space behind the barrier is limited or non-existent. TTI's test of T-lock connectors which showed 0.63 foot of displacement for non-vertically anchored portable CSSBs were not based on impact angles above 15 degrees and did not use the more popular types of connectors, most of which were not crash-tested. Based on the potential for large deflections as observed by Ivey, et al. and for situations where the extent of barrier displacement must be contained to some maximum level, vertical anchorage represents an important supplementary system.

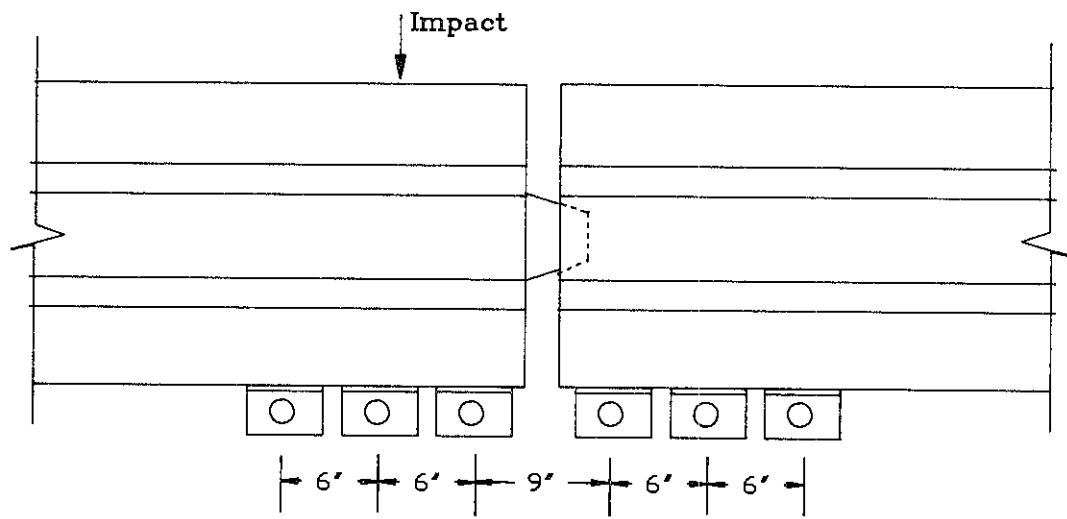

4"x4"x.25" steel angles with driven studs or anchor bolts used to anchor barrier to concrete pavement.

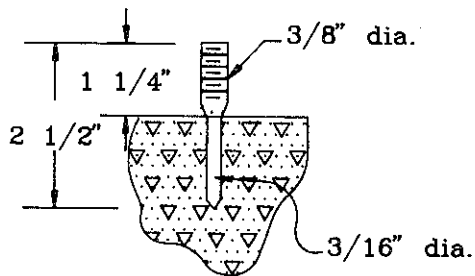
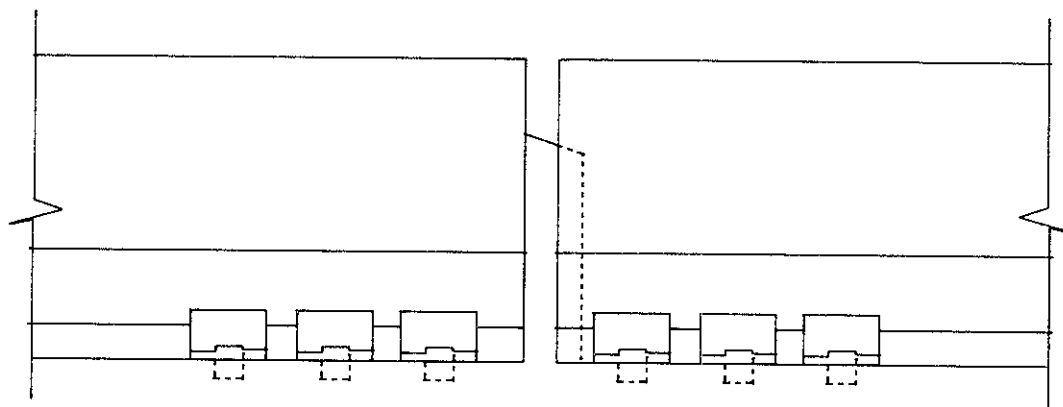

Driven Stud

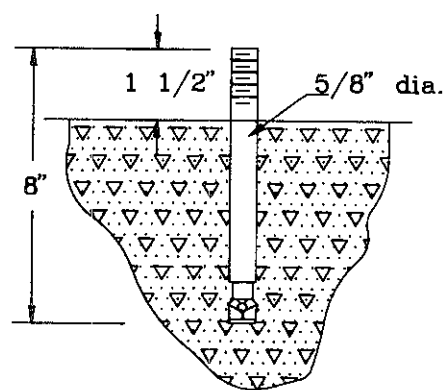

Drilled Anchor Bolt

Source: (5)

Figure 9. Anchor plates, studs and bolts

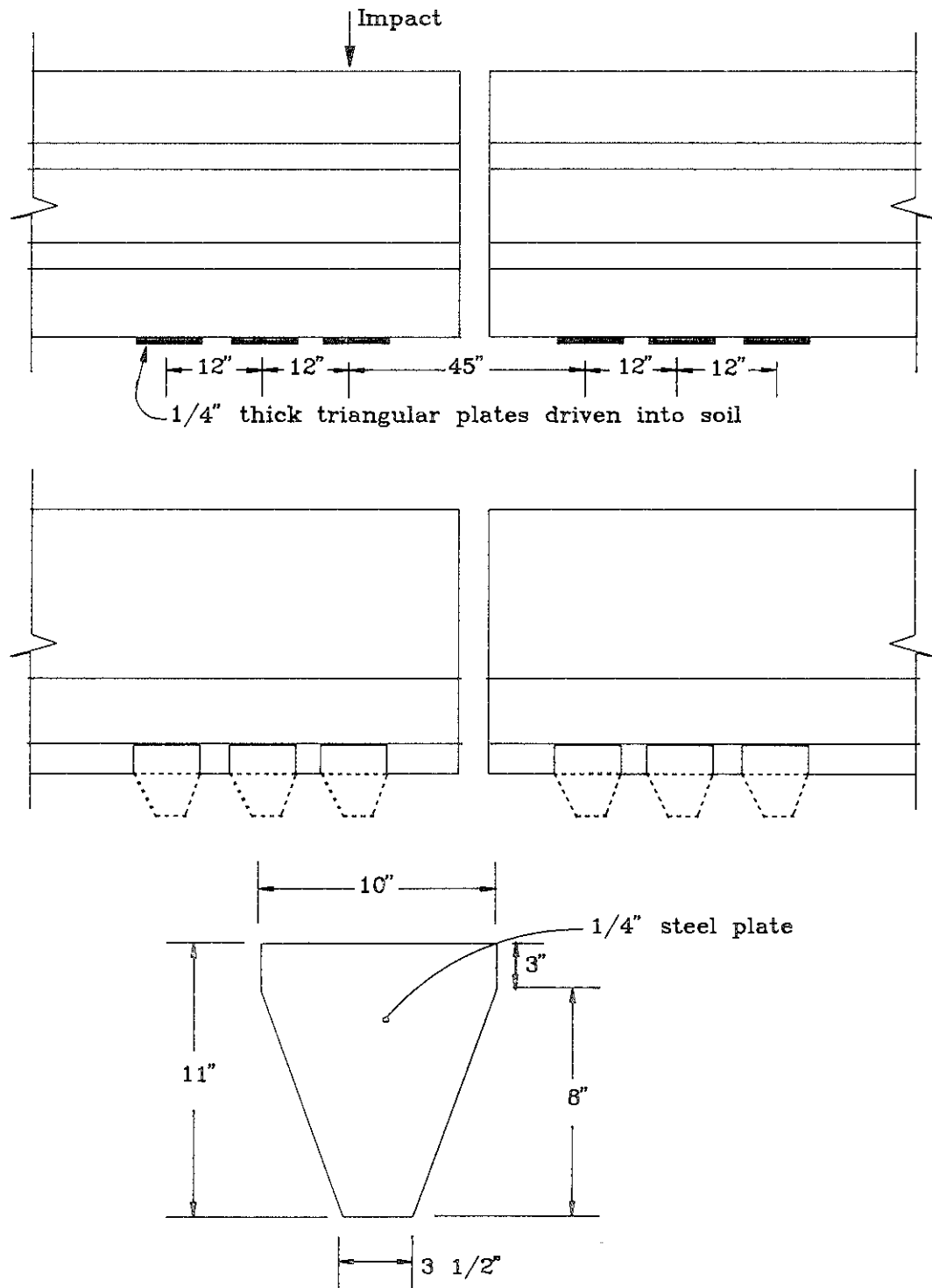

Source: (5)

Figure 10. Driven anchor plates

Table 1. Results of impact tests on barrier anchorage

Test Designation	Anchorage Design	Impact Location	Peak Impact Force (kips)	Impact Duration (sec)	Displacement of Barrier (in)	Comments
3825-C3	Angles With Driven Studs	3 ft. right of joint and 21 in. high	41.3	0.050	0	Barrier segments rotated about lower edge during impact but returned to upright
3825-C4	Angles With Driven Studs	3 ft. right of joint and 21 in. high	48.8	0.050	18	Studs failed
3825-C5	Angles with Drilled Anchor Bolts	1 ft. right of joint and 21 in. high	52.4	0.060	0	Studs failed
3825-C6	Angles with Drilled Anchor Bolt	1 ft. right of joint and 21 in. high	53.6	0.047	36	Anchor bolt failed
3825-C7	Angles with Drilled Anchor Bolts	Centered on joint and 21 in. high	57.9	0.046	72	Anchor bolt failed
3825-C8	Triangular Plates	2 ft. right of joint and 21 in. high	69.5	0.060	0	Impacted barrier segment rotated about lower edge and came to rest on its side.

Source: (5)

III. CURRENT PRACTICES

A. Need for Vertical Anchorage. Crash tests conducted on portable CSSBs over the past 15 years substantiate the possibility of lateral movement when barriers are impacted by highway vehicles, but those tests also indicate a high degree of randomness in the observed deflection, thus making it difficult for researchers and practitioners to be certain that a specific maximum deflection can be estimate at field installations. The practitioners' uncertainty about barrier movement has apparently been resolved by judgmental applications of vertical anchoring systems. Six of the eight states visited have adopted at least an informal policy on anchoring portable CSSBs on bridges. Officials in Pennsylvania, Virginia, Maryland, Illinois, New York, and California agree that bridge work involving deck, sidewalk, and rail rehabilitation must often be done in situations where there is limited space to accommodate portable CSSBs, workmen, equipment, pedestrians, and vehicular traffic. New Jersey, Florida, and Ohio are also users of vertical anchorage for portable CSSBs. Thus at least nine states have found that there are mitigating circumstances where the lateral movement of portable CSSBs must be restricted by supplementary vertical anchorage. As can be seen in Tables 2 and 3, a variety of horizontal connectors are used. Thus, the strength characteristics of vertical anchoring systems will vary. Of the nine states mentioned above only Ohio has established preliminary detailed guidelines for the application of anchoring systems. Practices in a selection of states are discussed below.

B. Application and Design of Anchoring Systems in Selected States. Ohio requires base restraints on portable CSSBs whenever they are installed on the outside of curves, installed next to open ditches, used as a traffic separator in medians narrower than five feet, or used in other locations sensitive to lateral deflection. This is accomplished by means of a narrow strip of asphalt one-to-two inches high placed next to the barrier base on the side away from traffic. If traffic is on both sides, restraint is accomplished by fastening two temporary one-foot sections of steel channels to the pavement so that they fit in the base keyway. If dowel holes are provided in the barrier, two temporary one-inch dowels are installed in the pavement through the dowel holes.

Ohio has a systematic process for determining the vertical anchorage requirements of portable CSSBs on bridge decks. This procedure is the result of recent research (18) aimed at improving the design of Ohio's temporary CSSBs, CSSB connectors, and anchoring systems. Ohio's standards for barrier anchorage, adopted in June 1988 (19), consider speed

Table 2. Connectors and displacement control methods

States	Barrier Connectors	Supplementary Methods for Controlling Lateral Displacement
Ohio	Bolt and rebar loop. Tongue and groove Plate insert	1-2 inch asphalt strip behind barriers 1-foot steel plates attached to pavement below barrier. Dowel holes in barrier with 1-inch diameter through bolts with nuts or with resin embedment 6 inches in concrete. Spacing of bolts based on clearance, barrier design, and vehicle speed.
Pennsylvania	Tongue and groove.	7/8-inch to 1-inch diameter through bolts with nuts. 1-inch diameter bolts in resin embedment at depth 4-6 inches in concrete. Pullout strength of 18,000 psi. Spacing of 1.5-2 feet.
Maryland	Tongue and groove. Plate insert.	1.25-inch diameter through bolts with nut washers and anchor plates. Minimum bolt tension of 16,000 lbs. Minimum bolt shear 13,000 lbs. Bolt spacing of 6 feet on traffic side.
Virginia	Tongue and groove. Pin and rebar loop.	4.0 x 5.4 x 12-inch slip plates attached to pavement below barrier. Barrier length ranges 10-20 feet. Two plates per barrier unit. 1.25 diameter through bolt, with nuts, washers and resin embedment at minimum depth of 5 inches. Concrete minimum strength of 4,000 psi. Bolt pullout strength of 44,200 lbs.

Table 3. Connectors and displacement control methods (Table 2 continued)

California	Pin and rebar loop.	Barrier length of 20 feet. Anchor bolt in resin embedment at 6 inches minimum. Two bolts per barrier and located at 3.75 feet from each end. 1-inch diameter drift pin placed in dowel behind barrier, 5 inches into deck, 1 foot from barrier end. 1 foot x 1 foot berm behind barriers.
New York	H-Pin (I-Beam)	1-inch diameter anchor pins embedded at 5 inches in resin in concrete, 1 foot 6 inches in asphalt and 2 feet 6 inches in unpaved areas. Spacing based on barrier length.
Illinois	Pin and rebar loop. Pin and wire rope	1-inch diameter pins through dowel holes in barriers. 3 pins per 10-foot barrier segment. Styrofoam pads beneath barriers. Strength of anchorage units not available.
Florida	Tongue and groove. Pin and rebar loop. Pin and rebar loop.	0.75-inch anchor bolt and plates which serve as connector and vertical anchor. One bolt per joint. Pullout strength of 14,000 lbs. Separation equals barrier length.
New Jersey	Tongue and groove. Tongue and groove with splice plate.	1-inch diameter bolt and nut in embedment resin. Embedment depth of 7 inches in concrete and 13 inches in asphalt minimum. Pullout strength from concrete is 20,500 lbs. 2 feet spacing on one side. 4 feet spacing on both sides.

(m.p.h.), roadway width (feet), and impact severity (foot-kips) in determining the clearance required between portable CSSBs and the edge of bridge decks. Speed and roadway width are also used to determine the number of anchor bolts. Ohio's barrier anchorage procedure is presented in Figures 11 through 15. At the request of the Ohio Department of Transportation, the full text of Ohio's procedure is presented in Appendix A in order to minimize misrepresentation. As indicated in Figure 11, Ohio requires that all temporary barrier segments on bridge decks be fastened to the pavement using one-inch diameter, high-strength through-bolts or approved resin anchors, and that resin anchors be embedded a minimum of six inches in firm concrete. The preferred location of the anchors is on the traffic side of the barriers. Two anchors per barrier segment are the minimum requirement. The location and design of the dowel holes are presented in Figure 16. The Ohio standards (19) were based on crash tests conducted by the California Department of Transportation on portable CSSBs with pin and loop connectors in the mid-1970s. Ohio's pin and loop connector design is indicated in Figure 17. The Ohio report (18) recommended that the clearance distance between the edge of the portable CSSBs and the edge of bridge decks should never be less than one foot and that unanchored barrier chains, except for impact severity less than 30,000 foot-pounds, must be at least four feet away from the edge of the deck.

Currently, Pennsylvania has no uniform standard (17) on the dowel hole and bolt system used for anchoring portable CSSBs to bridge decks. Vertical anchorage is determined on a case-by-case basis by district engineers. A common practice in some districts involves the use of 7/8-inch to 1-inch diameter bolts cemented with a resin at depths of 4 to 6 inches in bridge decks to develop a pull-out strength of about 18,000 lbs. According to field officials, this treatment has been sufficient to contain most automobile impacts. However, the containment of errant trucks cannot be assured. One official noted that on long bridges the repetitive nature of drilling holes in bridge decks and inserting cementing resin and bolts could result in reduced care by workers in insuring that the holes are properly prepared to enable a strong bond between the concrete, the bolts and the resin. Occasional failures in the bond between the bolts, resin, and concrete and in concrete of the pavement or the barrier have been observed. Field engineers could not recall any bolt failure due to shear or tension. However, there is increasing concern about the adequacy of vertical anchorage for restraining and redirecting trucks. Pennsylvania has just initiated research on vertical anchoring systems aimed at evaluating current practices and developing standard specifications. Figure 18 illustrates a dowel hole with anchor bolt, nut, and washer at a construction site in Philadelphia. The bolts were spaced at approximately 18 inches. Figure 19 shows a bridge deck construction project where the barriers were anchored with reuseable bolts inserted in the deck through dowels in the portable barrier. Limited

BARRIER ANCHORAGE REQUIREMENTS:

THE ANCHORAGE REQUIREMENTS FOR TEMPORARY PRECAST CONCRETE BARRIERS CAN BE DETERMINED BY USING THE FOLLOWING PROCEDURES.

1. ENTER FIGURE 12, WITH THE KNOWN ROADWAY WIDTH AND THE POSTED SPEED LIMIT * AND FIND THE NUMBER OF ANCHORS REQUIRED WHEN THE MODIFIED (EXISTING) BARRIER DESIGN IS USED.

OR

ENTER FIGURE 13, WITH THE KNOWN ROADWAY WIDTH AND THE POSTED SPEED LIMIT * AND FIND THE NUMBER OF ANCHORS REQUIRED WHEN THE PROPOSED BARRIER DESIGN IS USED.

2. IF THE BARRIER INSTALLATION IS TO REMAIN UNANCHORED, EITHER BECAUSE OF LOW IMPACT SEVERITY OR THE AVAILABILITY OF SPACE BETWEEN THE BARRIER AND THE EDGE OF THE BRIDGE DECK, ENTER FIGURE 14, WITH THE KNOWN ROADWAY WIDTH AND THE POSTED SPEED LIMIT * AND FIND THE IMPACT SEVERITY. THEN, WITH THE KNOWN IMPACT SEVERITY, ENTER FIGURE 15, AND FIND THE MINIMUM CLEAR DISTANCE REQUIRED FROM THE EDGE OF THE BRIDGE DECK AT WHICH THE BARRIER (MODIFIED OR PROPOSED) CAN BE LOCATED.

* THE POSTED SPEED LIMIT SHALL BE DEFINED AS THE SPEED THAT IS ACTIVELY ENFORCED EITHER BY LEGAL MEANS OR TRAFFIC CONTROL DEVICES.

ALL BARRIER SEGMENTS SHALL, WHERE REQUIRED, BE FASTENED TO THE BRIDGE DECK USING ONE INCH DIAMETER HIGH STRENGTH THRU BOLTS OR APPROVED RESIN ANCHORS. WHEN RESIN ANCHORS ARE USED THEY MUST BE EMBEDDED A MINIMUM OF 6" INTO FIRM CONCRETE. GENERALLY, ALL ANCHORS SHALL BE PLACED ON THE TRAFFIC SIDE OF THE BARRIER WITH THE ANCHOR PATTERN SYMMETRICAL ABOUT THE CENTER OF EACH TEN FOOT SEGMENT. EVEN THOSE PRECAST CONCRETE BARRIER SEGMENTS NOT OTHERWISE REQUIRING ANCHORING SHALL, WHEN LOCATED ON BRIDGE DECKS CROSSING OVER ROADWAYS, RAILROADS, AND/OR RECREATIONAL AREAS, BE SECURED BY NO LESS THAN TWO ANCHORS **.

** UNLESS BARRIER SEGMENTS ARE TO BE INSTALLED 6 FT. OR MORE (CLEAR DISTANCE) FROM THE EDGE OF DECK, EQUIPMENT, AND/OR PROBABLE WORK AREAS.

Figure 11. Barrier anchorage determination procedure of Ohio

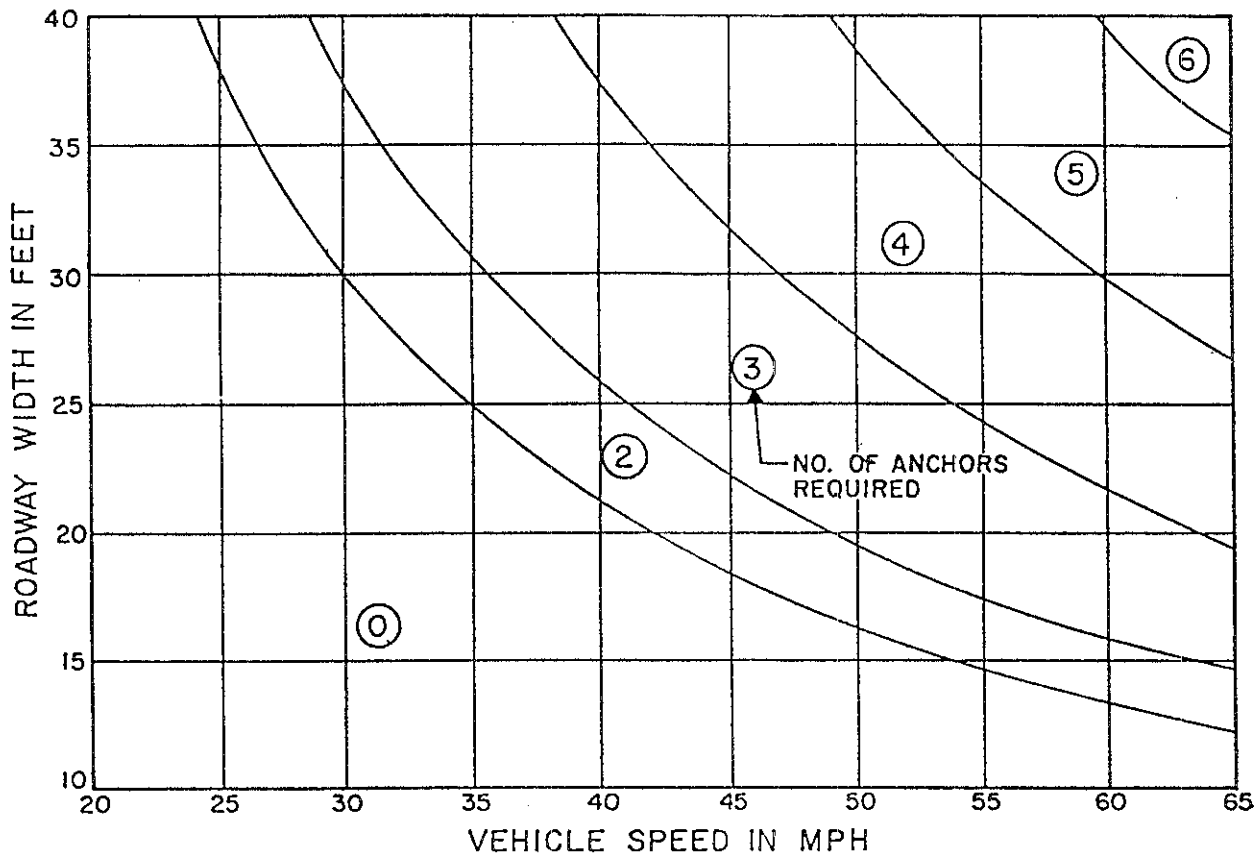

Source: Reference No. 19 (Ohio)

Figure 12. Anchors required per 10-foot barrier segment for Ohio's modified-existing barrier chains

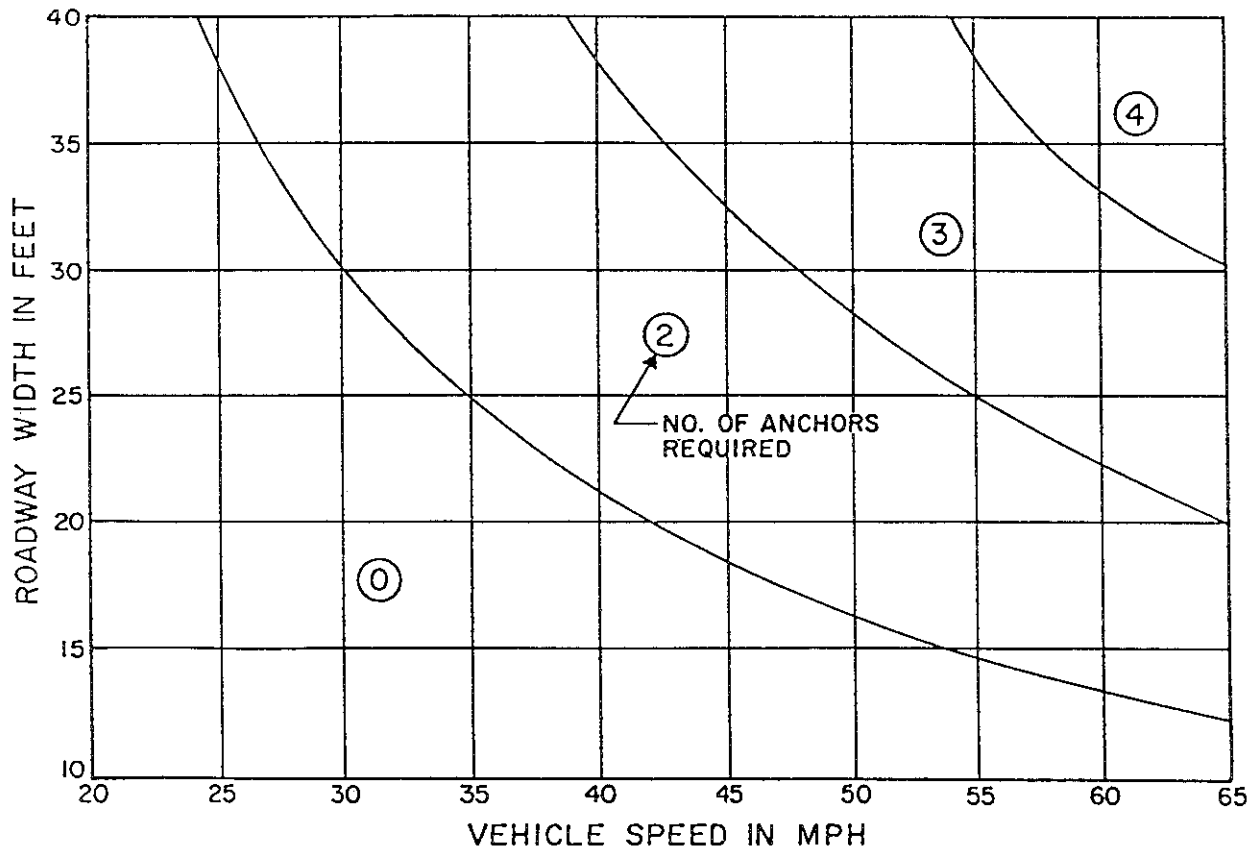

Source: Reference No. 19 (Ohio)

Figure 13. Anchors required per 10-foot barrier segment for Ohio's proposed barrier chains

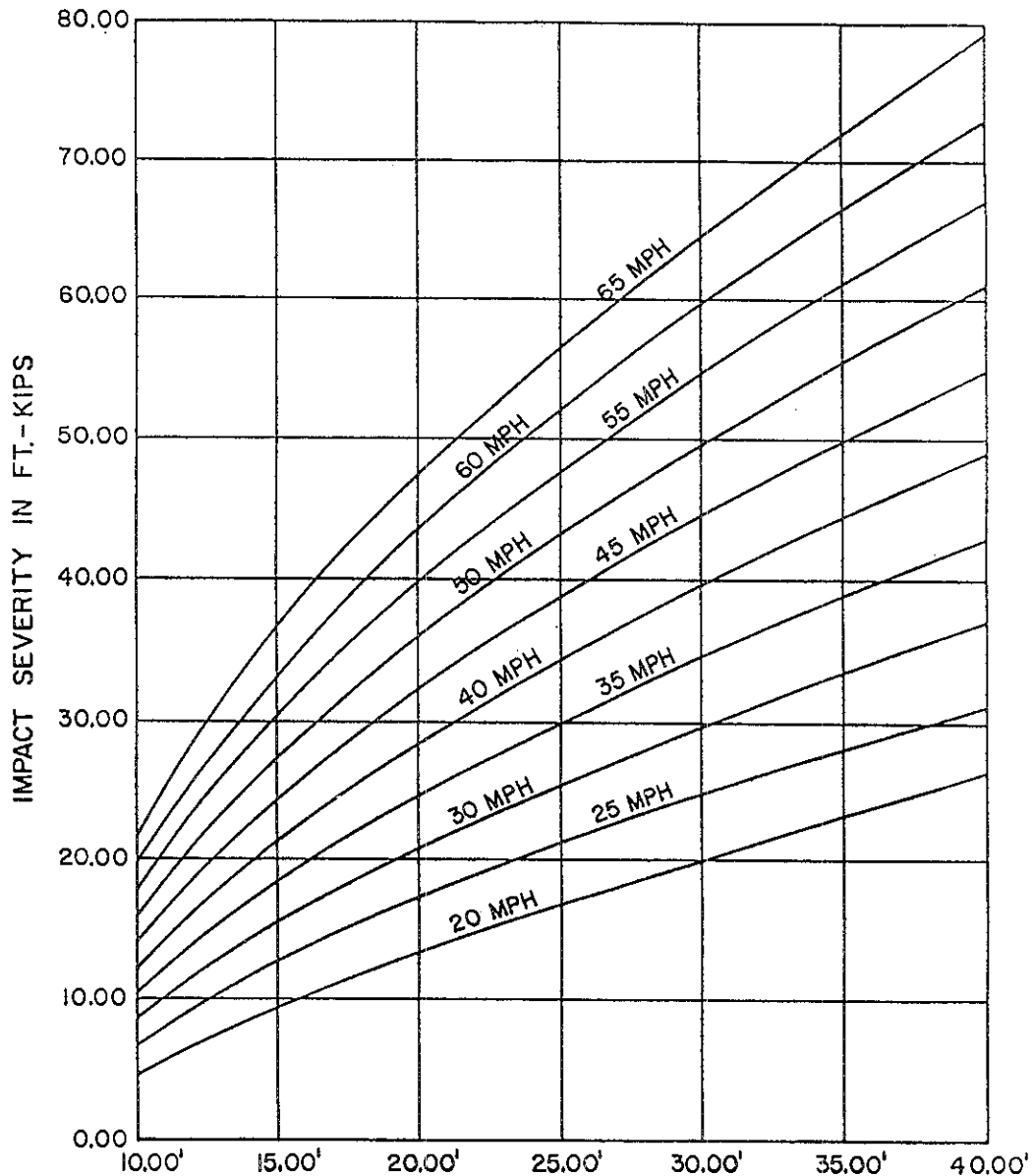

NOTE:

"ROADWAY WIDTH" SHALL BE DEFINED AS THE CLEAR DISTANCE BETWEEN THE TRAFFIC FACE OF THE PRECAST TEMPORARY CONCRETE BARRIER CHAIN AND THE PERMANENT BRIDGE RAILING OR THE FACE OF SIDEWALK OR SAFETY CURB.

Source: Reference No. 19 (Ohio)

Figure 14. Impact severity versus roadway width

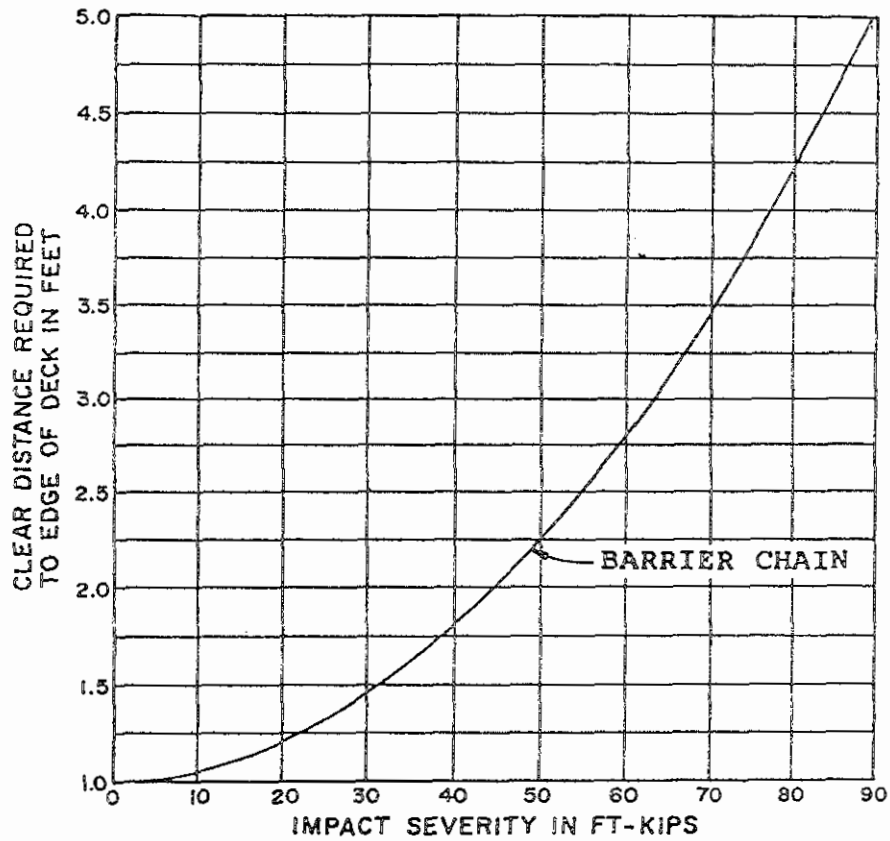

Source: Reference No. 19 (Ohio)

Figure 15. Placement versus impact severity of an unanchored barrier chain composed of 10-foot long segments

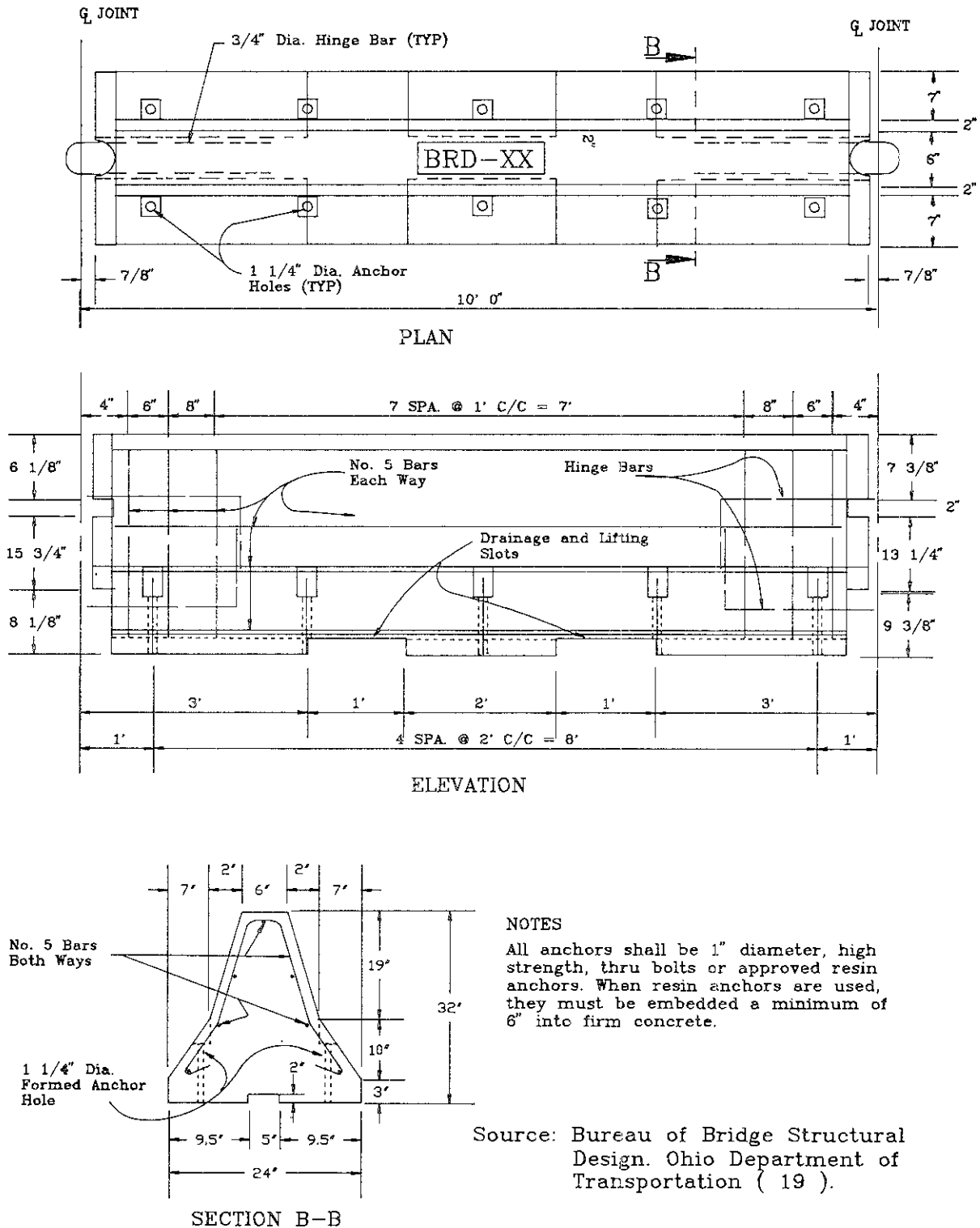
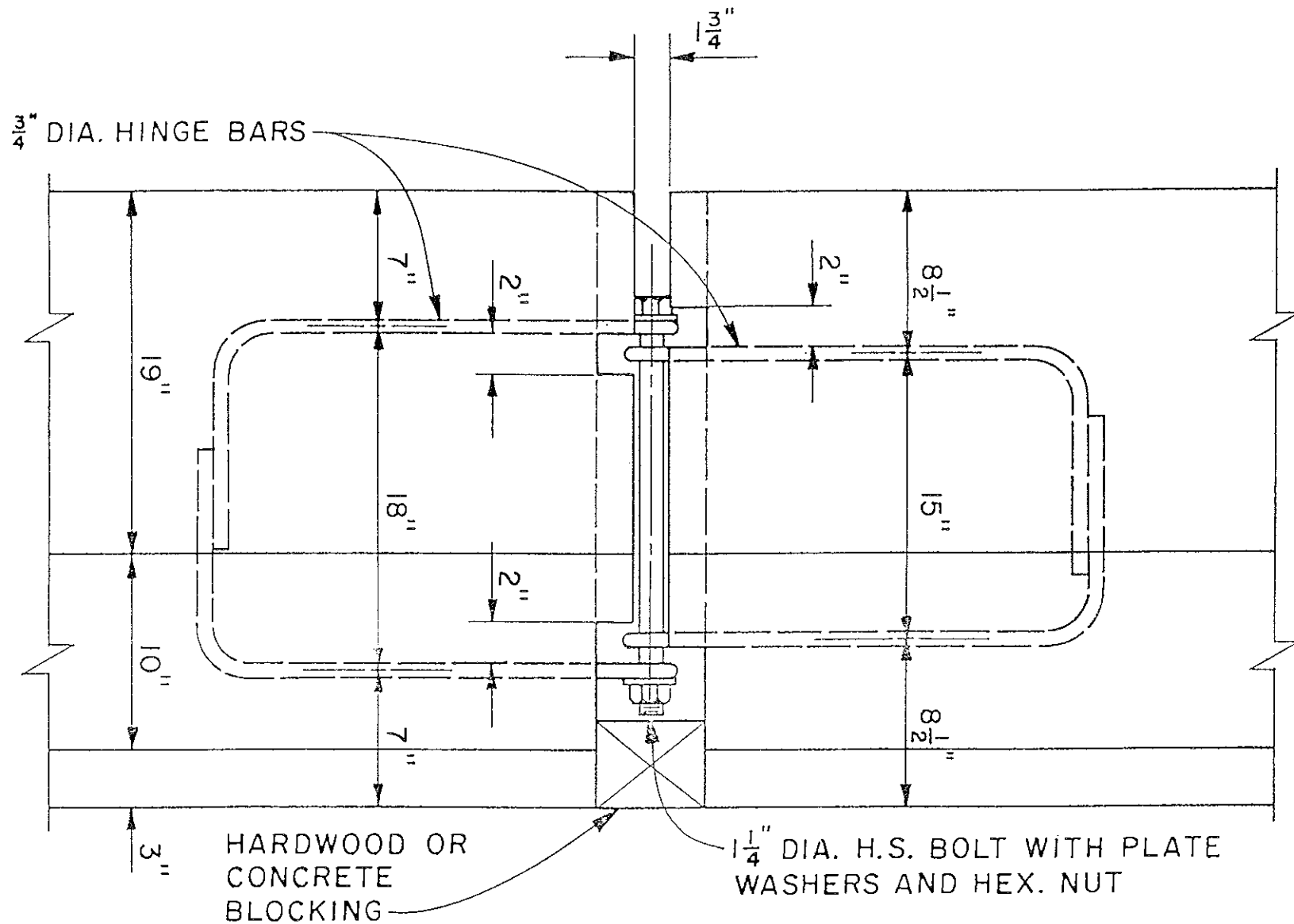
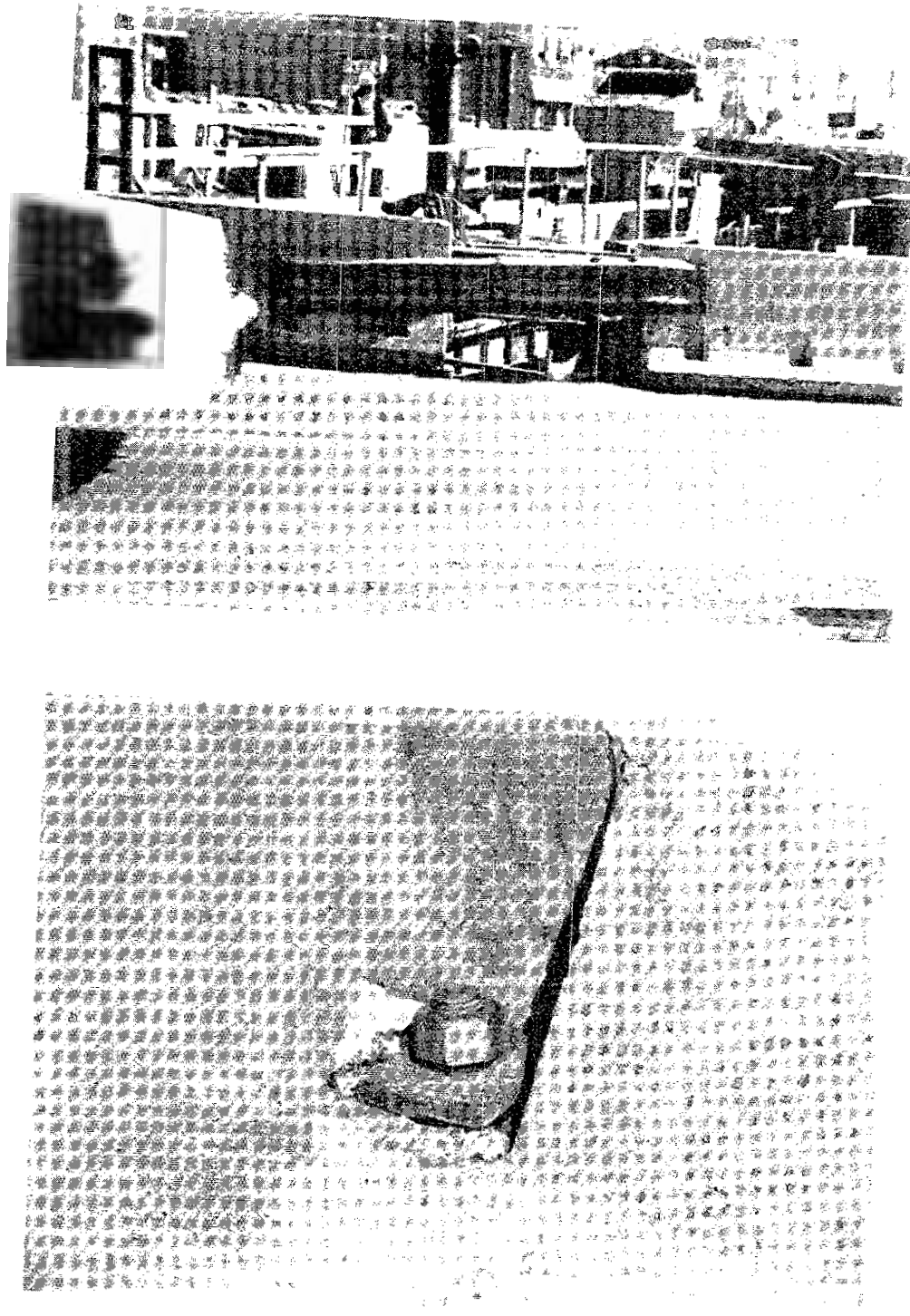

Figure 16. Partial details of Ohio's proposed anchorage of portable CSSBs on bridge decks.



Source: Reference No. 19 (Ohio)

Figure 17. Ohio's proposed design for pin and loop connectors



(Pennsylvania)

Figure 18. Anchorage with dowel bolt, nut, and washer

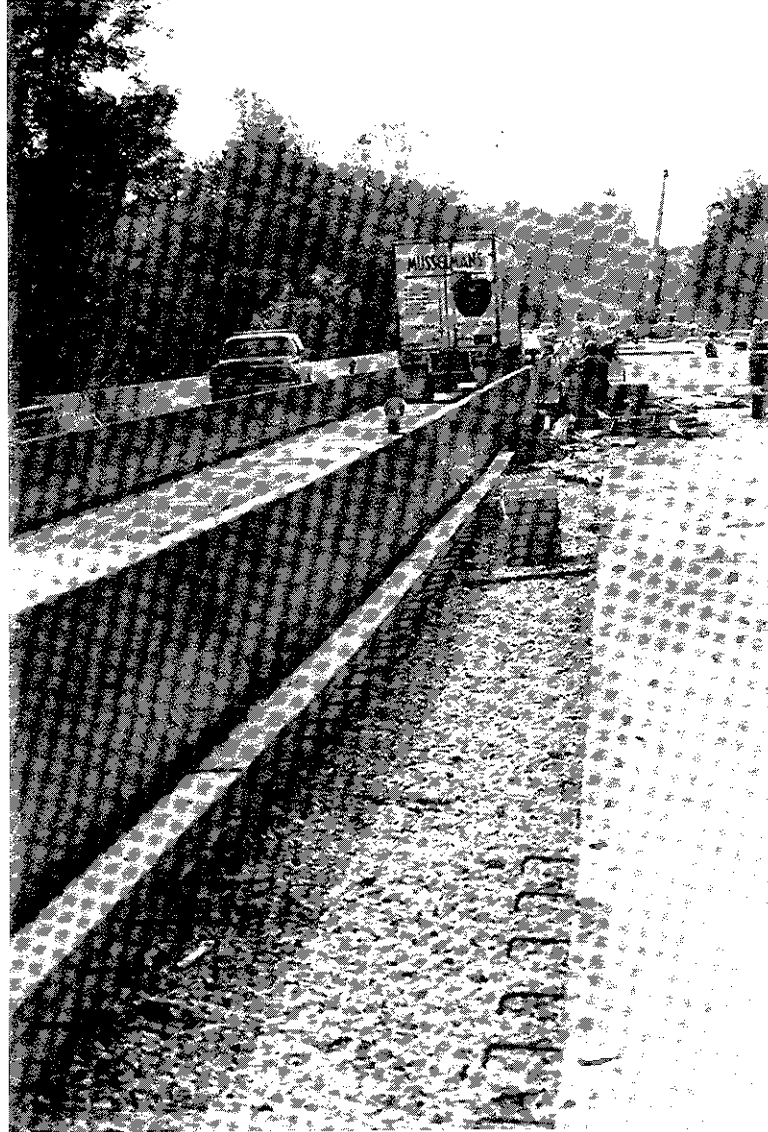

(Pennsylvania)

Figure 19. Protecting workers with anchored barriers

space for barrier displacement, reduced lane width, and worker protection were the primary reason for this application of vertical anchorage.

The State of Maryland has an established practice of routinely anchoring portable CSSBs to bridge decks during long-term construction work. Only the barrier segments located on bridges are fastened to the pavement with a system of anchoring plates, epoxy-coated open-coil inserts for attaching the plates to the barriers, and 1.25-inch diameter bolts with nuts and washers for attaching the plate to bridge decks. Figure 20 presents the material specifications and method of vertical anchorage adopted by the state. A minimum working load tension of 16,000 lbs. and shear of 13,000 lbs. are specified for the bolts. The epoxy-grouted bolt system for barrier attachment is required to develop a minimum compressive strength of 6,500 pounds per square inch in 72 hours. As shown in Maryland's standard drawing (Figure 21), the two anchoring plates used on standard 12-foot single-faced portable CSSBs are located three feet from the ends of each segment. Figure 22 presents the connection details for single-faced and double-faced portable CSSBs used in Maryland. It should be noted that the installation of the anchoring system requires access to the under structure of the bridge deck for the placement of some washers and for tightening the longer bolt of each plate. Figure 23 depicts a finished installation. Highway officials and field engineers could not recall any failure of the vertical anchoring system during traffic accidents and are satisfied with its performance, although this method of installation has not yet been evaluated by controlled crash tests.

In Virginia, the need for barrier anchorage is determined by field engineers on a case-by-case basis. Two methods of anchorage are used depending on the extent of lateral resistance needed and the location of barriers. Figure 4, presented earlier, depicts Virginia's practice of using 4-inch x 5.4-inch x 1-foot steel slip resisting plates for controlling lateral displacement; these are anchored to the pavement in the keyway beneath portable CSSBs. This type of anchorage is used on installations separating lanes of traffic flowing in opposite directions and on surfaces superelevated at a rate greater than 0.75 inches per foot. It is not used on bridge decks as exterior parapets or railings. Each plate is attached with two machine bolts and two washers. Two slip plates are used per barrier segment; the segments range in length from 10 to 20 feet. Portable CSSBs which function as exterior parapets are anchored either with anchor bolts, washers, and nuts embedded in the pavement or with anchor bolts, washers, and nuts applied to holes drilled through bridge decks. These two methods are illustrated in Figure 24. The system using embedded nuts is required to develop a minimum pullout strength of 44,200 lbs. The compression strength of the barrier has a minimum rating of 4,000 pounds per square inch.

GENERAL NOTES

MATERIALS

- Concrete: All concrete shall meet the requirements of Mix No. 6 (4500 p.s.i.)
- Reinforcing Steel: All wire fabric shall be 4"x4"-W4xW4
- Structural Steel: All structural steel shall meet the requirements of A.S.T.M. A-36 or better.
- Anchor Bolts: All anchor bolts shall be as indicated on details. If not specified this shall be A.S.T.M.-A325.
- Coating: Face adjacent to roadway and top of precast barrier to be coated with two coats of white epoxy paint. Cost of coatings to be included in bid price for the barrier, or item which include barrier.

METHODS OF ANCHORAGE CONNECTION TO CONCRETE DECKS

- EXISTING BRIDGE DECK TO BE REMOVED

Holes for anchor bolts in existing bridge deck shall be drilled. Use 1/4" o bolts with 5 1/2" x 3/4" square washer under existing deck slab, as shown. Bolts shall be of sufficient length that when nut is tight all the threads of the nut are engaged. Provide Type "A" plain washer SAE N (narrow) for each 1 1/4" o bolts at connector plate.

- EXISTING BRIDGE DECK TO REMAIN

Holes for anchor bolts in existing bridge deck shall be cored. Use 1 1/4" o bolts with 5 1/2" x 5 1/2" x 3/4" square washers under existing deck slab, as shown. Bolts shall be sufficient length that when nut is tight, all the threads of the nut are engaged. Provide Type "A" plain washer SAE N (narrow) for each 1 1/4" o bolt at connection plate. The Contractor is alerted, that it is the intent, that as little damage as possible will be done to the reinforcing steel in the bridge deck. Therefore, the Contractor shall locate the reinforcing steel and space the bolts to miss the reinforcing steel, all as directed by the Engineer. Fill all cored holes with epoxy grout after barrier is removed. (See below for grout composition).

- NEW BRIDGE DECK

1 1/4" o bolt to be placed in an epoxy coated open coil anchor insert (cast in slab) whose minimum working load tension strength is 16,000 # and shear strength is 13,000# with a minimum length of 7 1/2". Coil to be tapped for a 1 1/4 N.C. thread bolt. No insert shall be longer than slab depth minus 1". Provide Type "A" plain washer SAE N (narrow) for each 1 1/4" o bolt at connection plate. Fill all inserts with epoxy grout after barrier is removed. (See below for grout composition).

- GROUT COMPOSITION

Any areas of bridge decks, to remain in place, damaged as a result of anchoring temporary concrete barriers (anchor holes, etc.) shall be repaired to the satisfaction of the Engineer using an epoxy grout. Epoxy grout shall consist of sand and epoxy, mixed by volume according to manufacturers recommendations. The epoxy grout shall be capable of developing a minimum compressive strength of 6,500 psi in 72 hours when tested in accordance with MSMT 501. Sand for epoxy grout shall conform to the Specifications Subsection 903.11

Source: Standard No. M (5.09)-83-143 Maryland Department of Transportation

Figure 20. Maryland's method for anchoring portable CSSBs

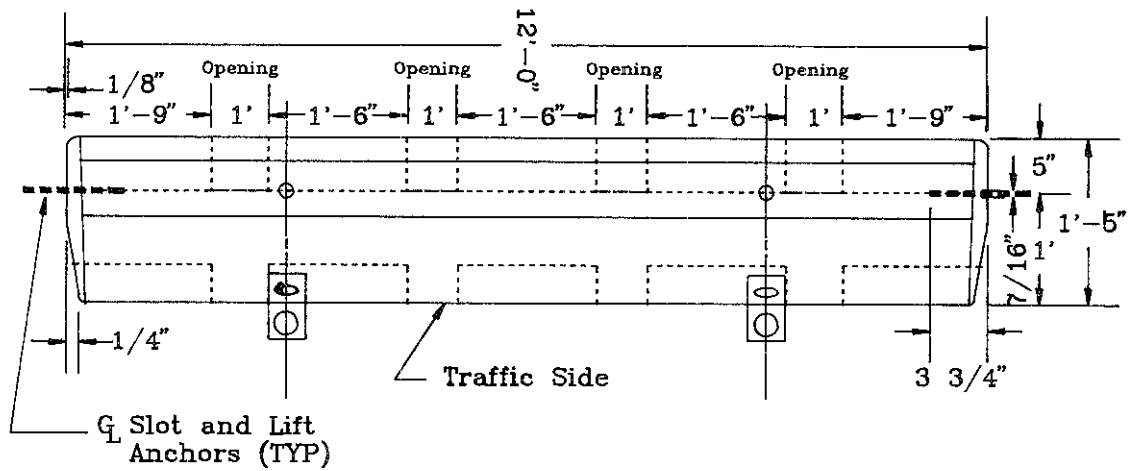

PLAN

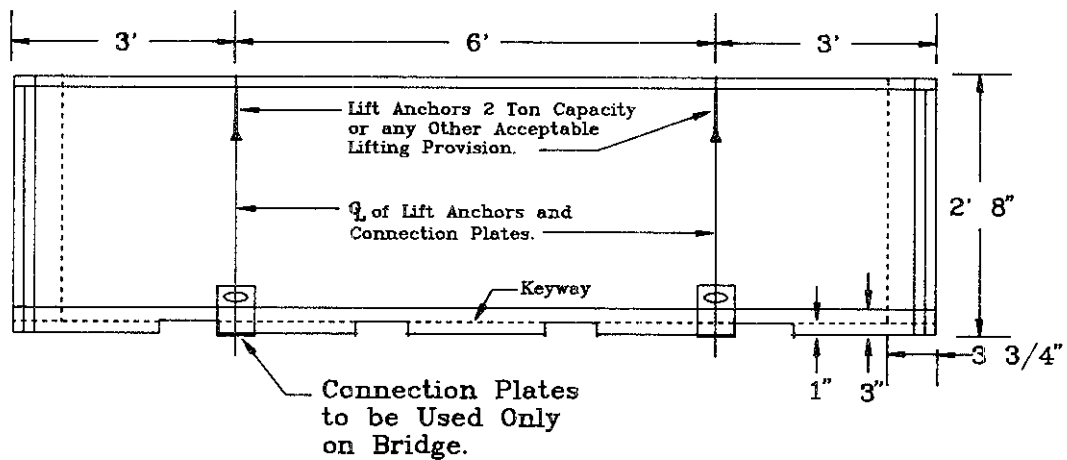

ELEVATION

Source: Standard No. M(509)-83-143
Maryland Department of Transportation

Figure 21. Location of anchoring system on Maryland's portable CSSB.

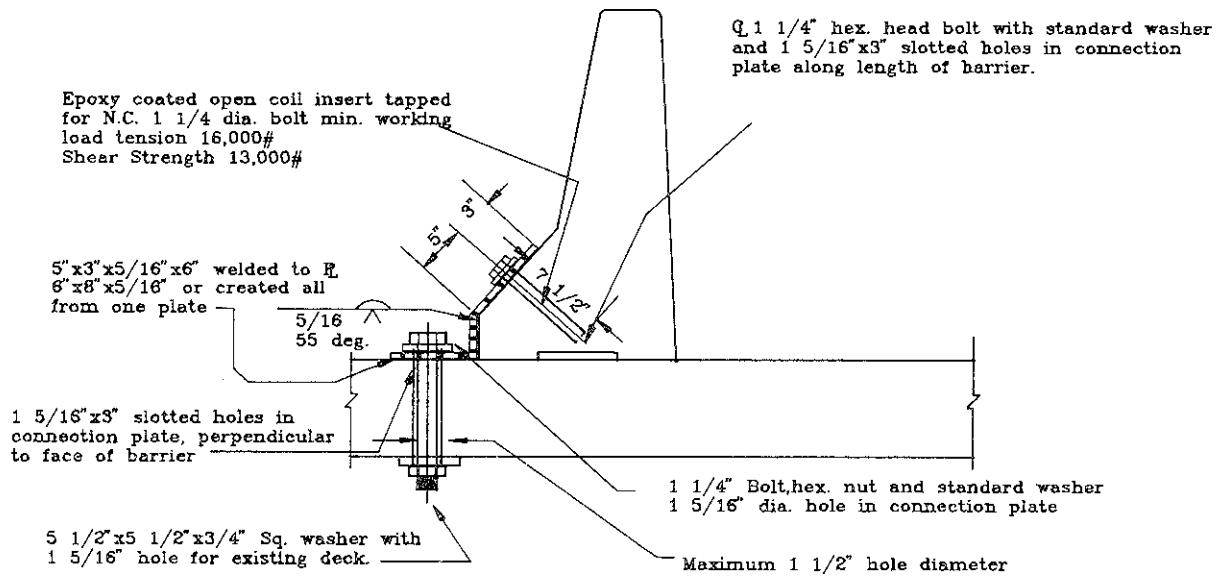

CONNECTION DETAILS

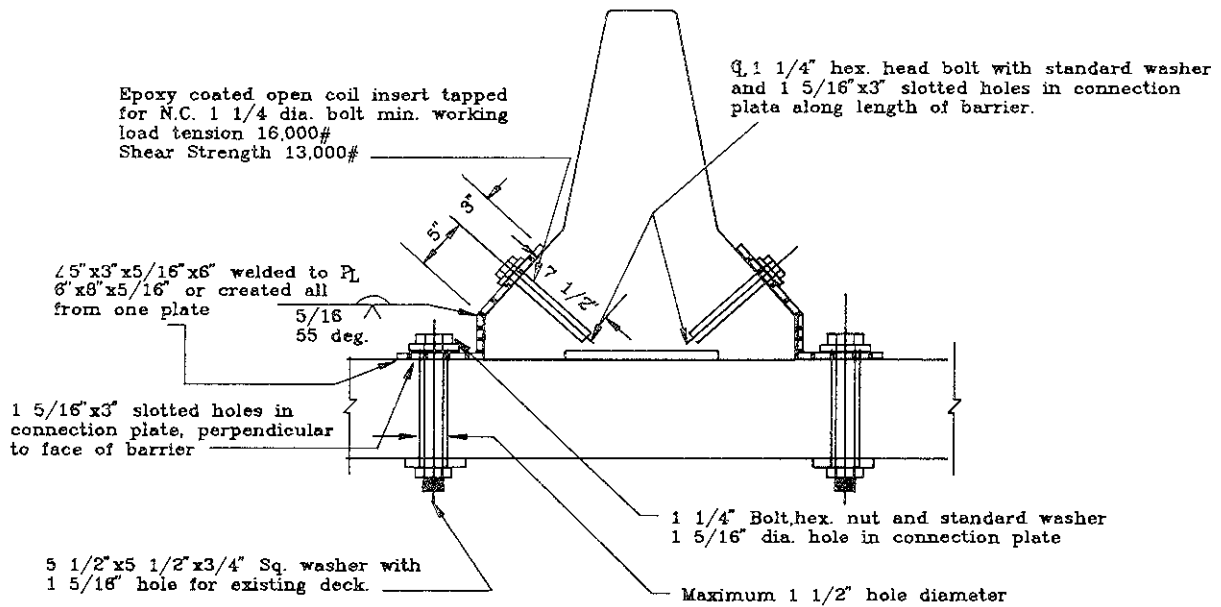

CONNECTION DETAILS

Source: Standard No. M(5.09)-83-143
 Standard No. M(5.09)-84-158
 Maryland Department of Transportation

Figure 22. Connector detail for Maryland's vertical anchoring system

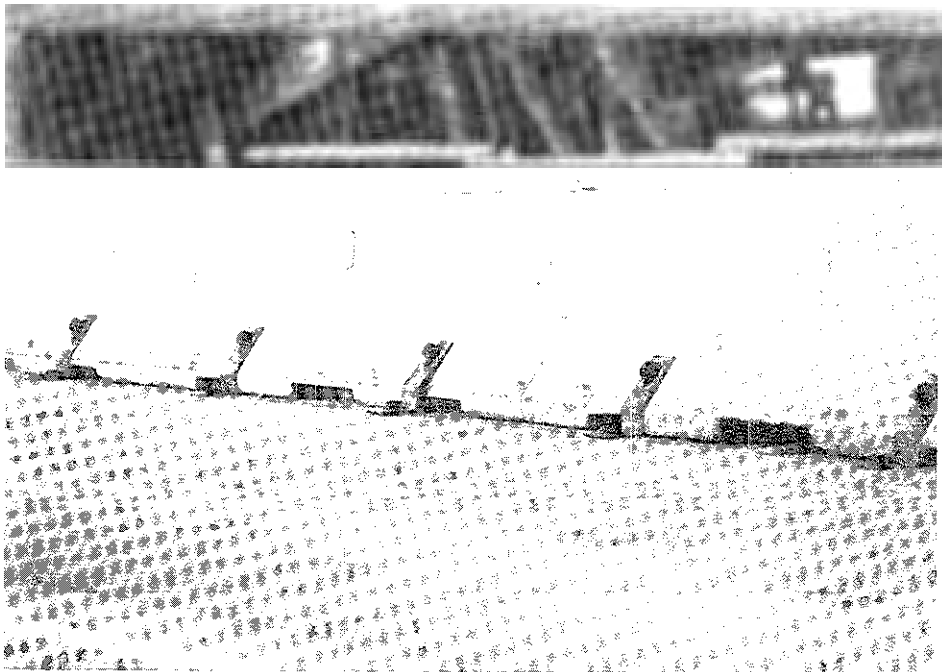
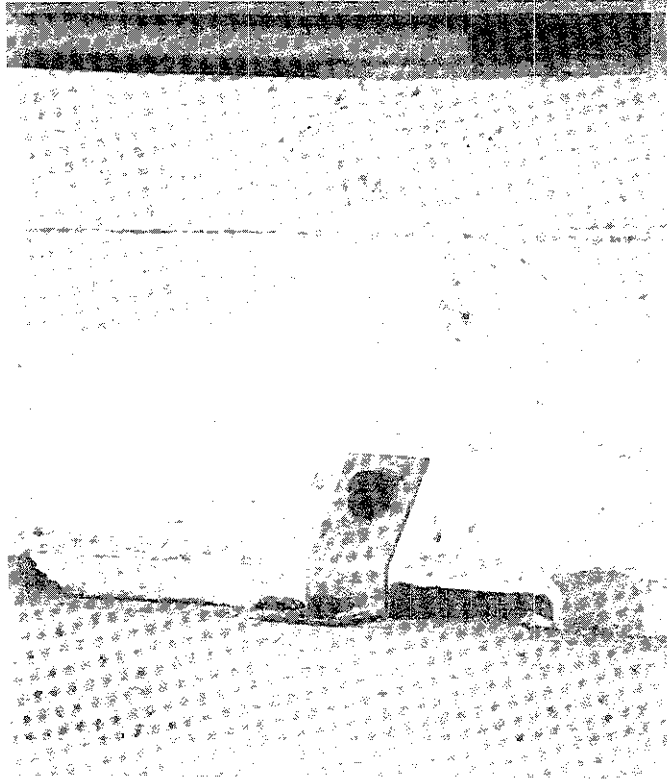
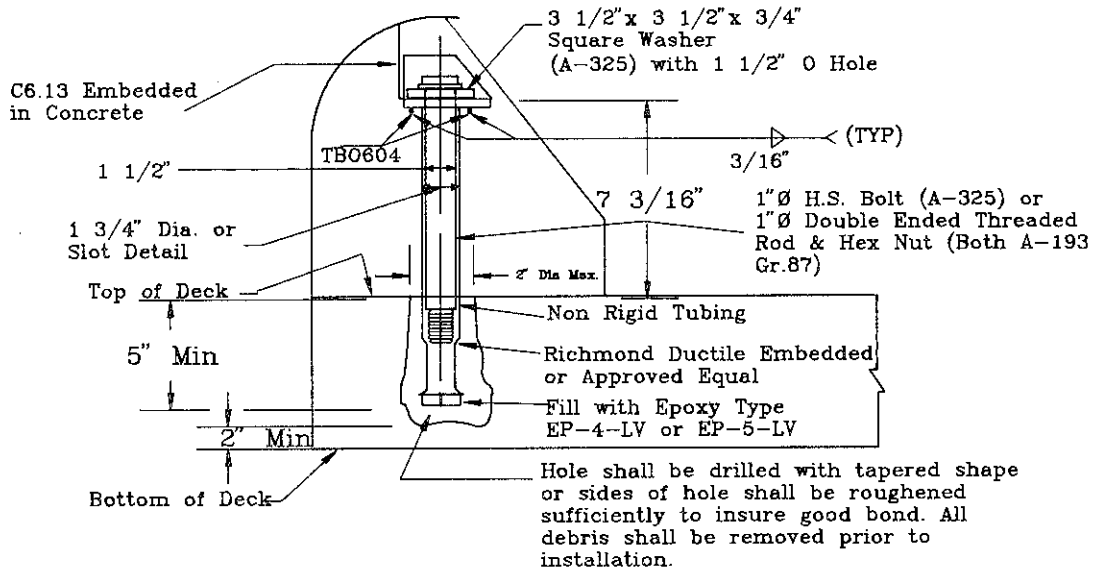
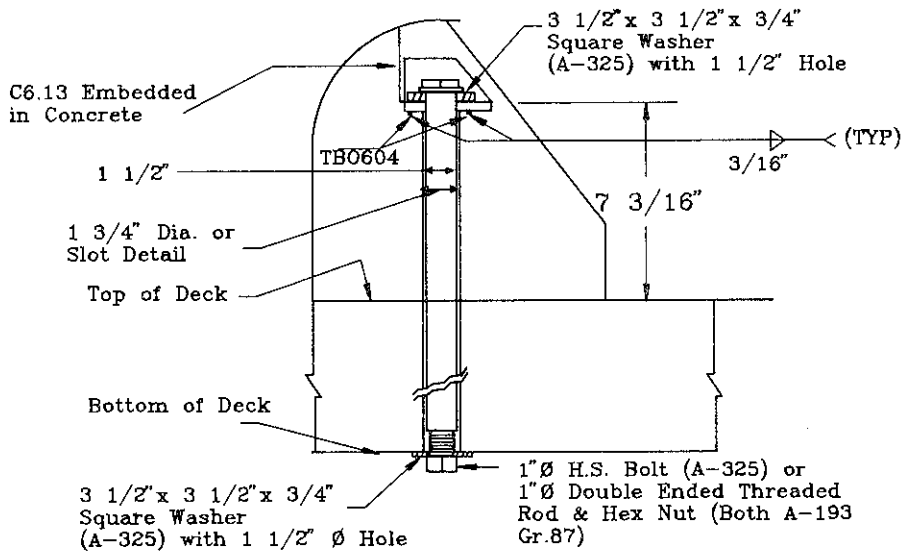

Figure 23. Installed vertical anchoring system in Maryland



DETAIL "A"



DETAIL "B"

Source: Virginia Department of Transportation

Figure 24. Virginia's use of anchor bolts

There is no routine use of anchored portable CSSBs at bridge work sites in California whenever there is a two-foot clearance between the base of barriers and any physical portion of the work. This two-foot clearance is believed to be sufficient for barrier deflection if it is struck by a vehicle. Whenever this clearance cannot be provided, such as along the edge of a bridge deck during widening operations, California requires portable CSSBs to be fastened to the roadway surface. When the barriers are placed on curves with radii too severe to make joints with pin and loop connections, the barriers are backed continuously with earth fill. California specifies a maximum gap size between barriers 3.5 inches. Barriers with joints which violate the gap size are required to have one dowel pin inserted in the pavement behind the barrier on both sides of the joints; i.e. on the side away from the traffic. The design characteristics of California's anchoring system are presented in Figure 25. The strength characteristics of this system were unavailable. California uses a standard 20-foot long double-faced portable CSSB. Dowel holes installed on the barriers are located on both sides, 3.75 feet from the ends.

The State of New York requires the use of vertical anchorage when the available space for the deflection of portable CSSBs on bridges is less than 11 inches. New York officials have reported that their design of horizontal connectors (see Figure 5) to which tension and grouting are applied has allowed them to control lateral displacement. New York uses several portable CSSBs of different lengths and has standardized the number of anchor rods (dowel pins) for each length. Figure 26 shows the number of anchor rods used for each segment length, the design of the dowel holes, and specifications for anchor rods. The one-inch diameter anchor pins are alternated on both sides of segments and begin and end 1 foot, 11.75 inches away from each end. Embedment requirements are 1 foot 6 inches into flexible pavement, 2 feet 6 inches into unpaved areas, and 6 inches into concrete bridge decks. When needed, anchor pins are placed in every anchor dowel.

Although Illinois' design standards allow the use of dowel bars for anchoring portable CSSBs to pavements, anchorage on bridge decks is an occasional practice which is determined by district engineers. Information on specific conditions which would warrant vertical anchorage was not available. Illinois' design standards state that barrier units placed on rigid pavement or median surfaces shall rest on styrofoam pads and that units placed on flexible pavement or shoulders shall be secured with dowel bars (pins) of one-inch diameter, be at least 12 inches long, embedded at least eight inches into the base material, and not project above the barrier surface. Illinois' officials believe that placing portable CSSBs on styrofoam pads aids in recovering much of the friction which could be lost when barriers are placed directly on roadway surfaces. Illinois uses the pin-and-loop connector design and a standard barrier length of ten feet. Six 1.50-inch dowel holes (three on each

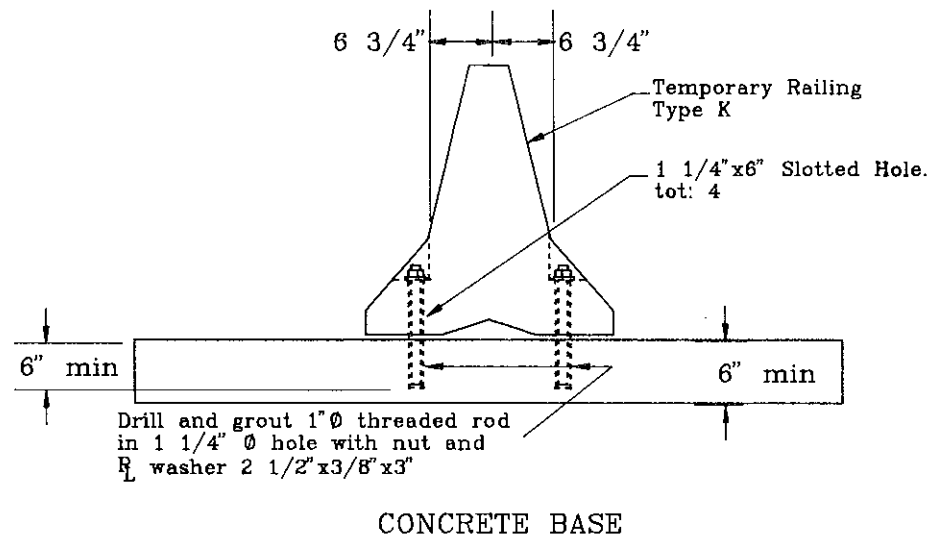

NOTES:

1. For end treatment; layout and crash cushions, where needed; see Road Plans or Special Provisions
2. Paint entire panel white, or cure with white pigmented compound.
3. All 3 1/2" gaps to be backed at the base width with # 8x19" dowel or 1" \varnothing pin each side of the joint. See Section K-K.
4. Alternative details for lifting the precast concrete panels of Temporary Railing Type K may be submitted by the contractor for the engineer's approval.
5. Where barriers are placed on curves and radii that are too severe to make up joints, barriers are to be backed continuously with earth fill. See Section H-H
6. Attach units to deck slabs when required by Bridge plans.

6x10" dowel, drill and grout in 1 1/4" hole and 5" deep with 1' of the joint.

Traffic This Side Only

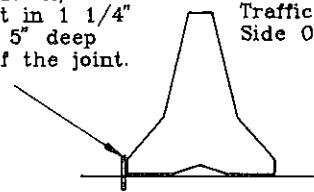

Section K-K (*)

* Section K-K is for P.C.C. pavement alternative detail, 1" \varnothing pins 2' long driven in A.C. or firm soil permitted, min 1'-6" deep.

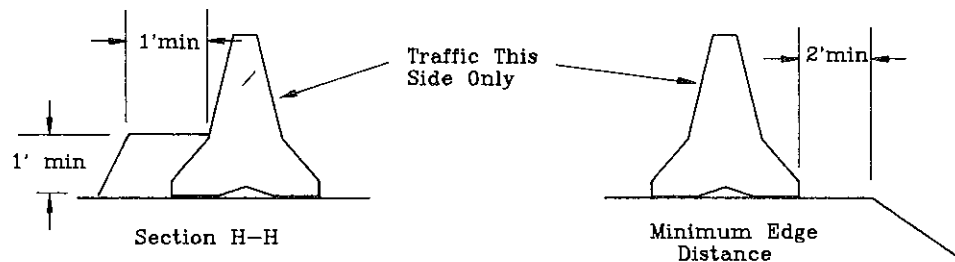

Source: California Standard Drawing B11-30

Figure 25. Characteristics of CSSB anchorage in California

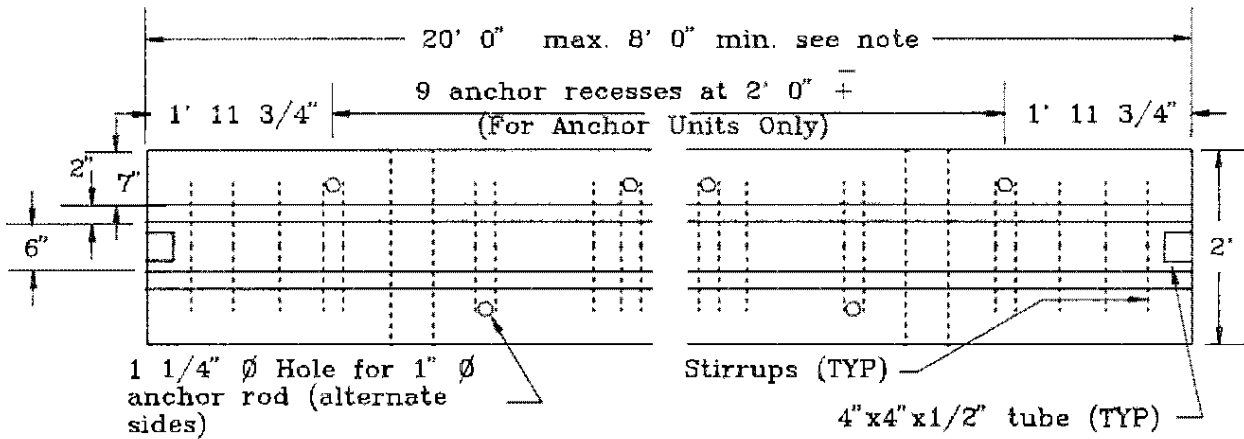

Nominal Length of Barrier Unit	Number of Anchor Pins
20 ft	9
18 ft	8
16 ft	7
14 ft	6
12 ft	5
10 ft	4
8 ft	3

For anchoring in concrete slabs, the tip may be omitted

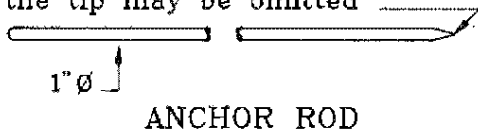

NOTES

The length of the anchor rods shall be such that the following minimum embedment lengths are obtained.

- (a) Into bridge decks and portland cement concrete pavements 0'-5"
- (b) Into flexible pavement 1'-6"
- (c) Into unpaved area 2'-8"

When anchor rods are in place, they shall not project above the plane of the concrete surface of the barrier.

Holes in bridge decks shall be 1 1/2" ϕ maximum and made with a core drill or any other approved factory drilling device that does not impart an impact force

In units that are to be anchored pins shall be required in every anchor recess. Anchors shall be 1" ϕ ASTM A36

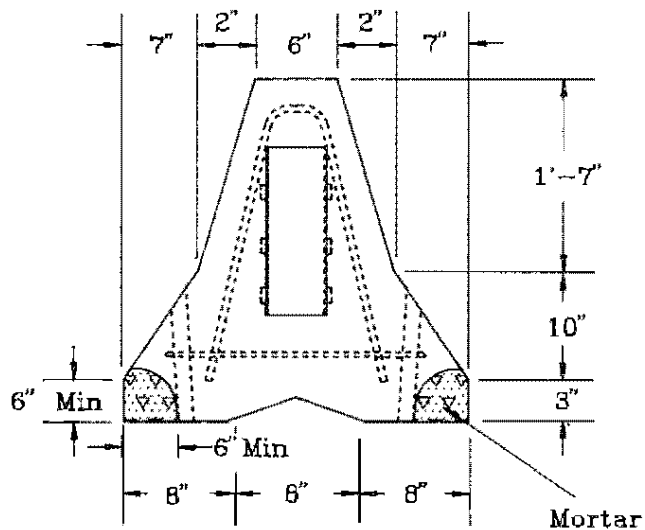

Place mortar in shaded areas when shown on the plans, when required by the table of joint treatment, or where directed by the engineer.

Source: New York State, Department of Transportation.
Standard Drawing 3R3

Figure 26. Partial detail of New York's system for anchoring portable CSSBs

side of a barrier unit) are used in vertical anchorage. One pair of these holes is located in the middle and the remaining pairs are located one foot from the ends of each unit. The design of the holes is similar to that of New York, presented in Figure 25, except that they are not alternated. Information on the strength characteristics of the anchoring system was not available. Figure 27 shows the arrangement of the dowel pins used on Illinois' standard ten-foot barrier units and a pinned barrier chain observed on an urban freeway construction project in Chicago. It was apparent during field inspection that either some of the pins were not installed to specifications or that they gradually moved upward due to repeated mild impacts by highway vehicles.

Conditions for using anchored portable CSSBs have not been explicitly defined in New Jersey's design standards. The state uses the portable CSSB shown in Figures 28 and 29 when it is determined that a special effort is required to restrict the potential for lateral movement. Anchor bolts are used in both Portland cement concrete (PCC) and bituminous concrete pavements. One-inch diameter expansion bolts are embedded in the PCC pavements and are required to develop a pull-out capacity of 20,500 lbs. when embedded at a depth of seven inches in concrete of a compression strength of 3000 pounds per square inch. The embedment depth of the anchor bolts used in asphaltic concrete pavements is 13 inches. Information on their pull-out strength was not available, but officials put more reliance on the shear strength of the bolts when they are used in asphaltic pavements. Bolts used in asphaltic concrete are threaded rods made from ASTM A36 steel. Nuts conform to ASTM A307. Anchorage must be applied to the traffic side of barriers and spaced at two feet, center to center. When bolts are used on both sides, they must be spaced at four feet center to center.

Florida's wall tie and anchor plate for portable CSSBs provides for both horizontal connection and vertical anchorage. The angle-type plate, shown in Figure 30, connects the barriers in the manner of side plates. One 0.75-inch diameter anchor bolt, placed in the middle of the base of the plate, is used to fasten it to bridge decks. One plate is used at each joint of the section of portable CSSB chain placed on bridge decks. Two 27-inch bolts, greater than the width of the base of barriers, are used to attach the plates to the base. Florida's portable CSSBs also provide for tongue and groove and pin and loop connectors. Regardless of the type of connectors, vertical anchorage is required for all portable CSSBs when they are used on bridges. All anchor bolts are required to have a pullout and shear capacity of 14,000 lbs. Wedge or chemical anchor are allowed in lieu of bolt, washer, and nut assemblies. The more common application involves assemblies where the anchor bolts are inserted in holes drilled through the deck of bridges. The minimum length of Florida's standard barrier is 12 feet, thus, the minimum separation between the anchor bolts is also 12 feet.

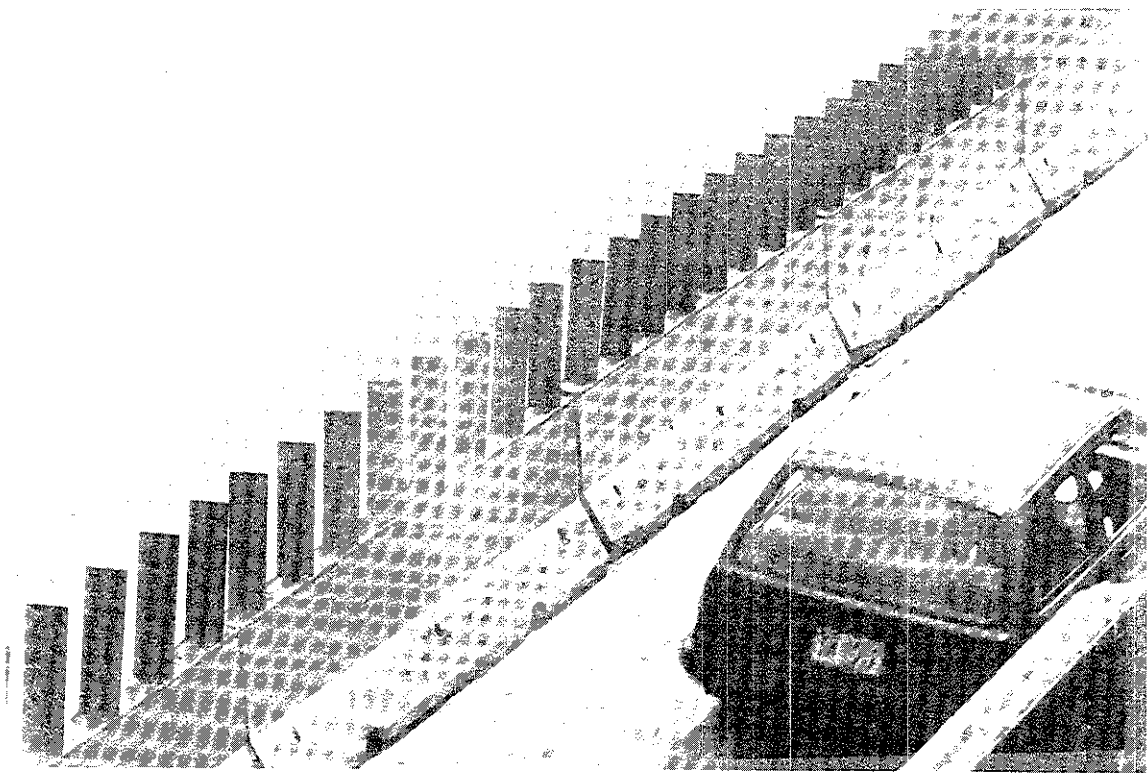
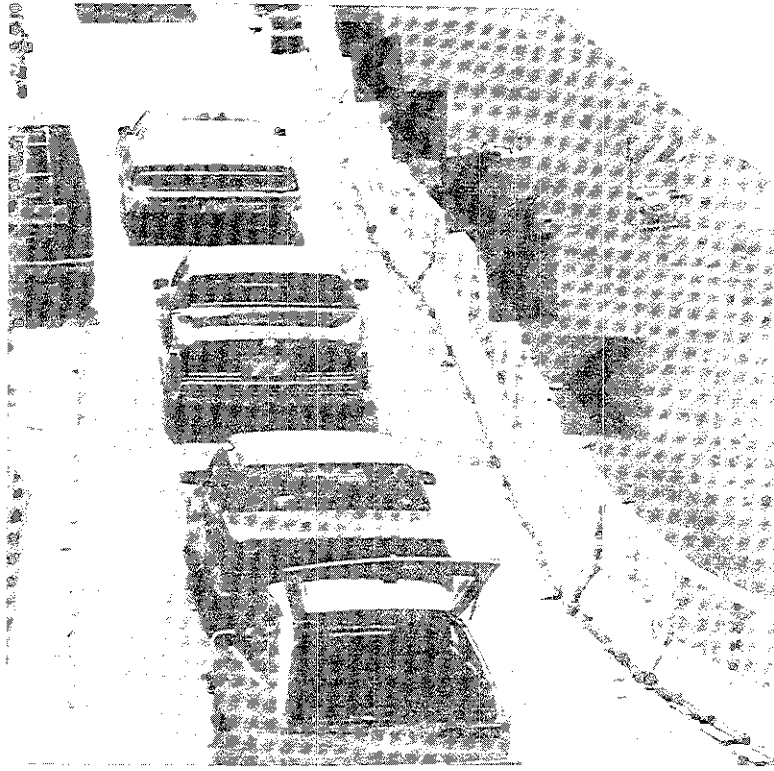
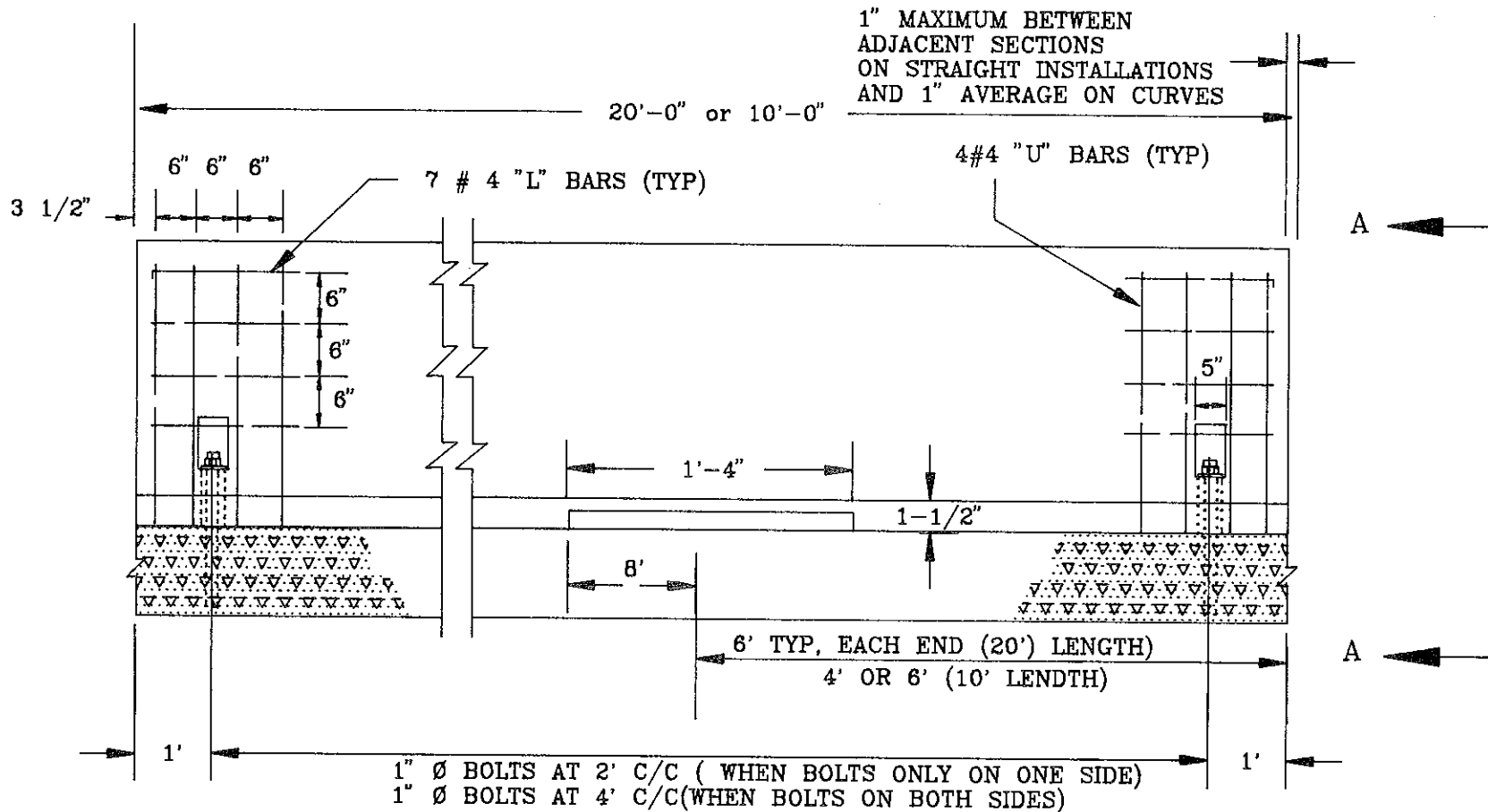

Figure 27. Barriers anchored with dowel pins in Illinois



42

Source: New Jersey Department of Transportation
See Figure 29 for Design Details.

Figure 28. Placement of anchor bolts on New Jersey's Type-1 barrier

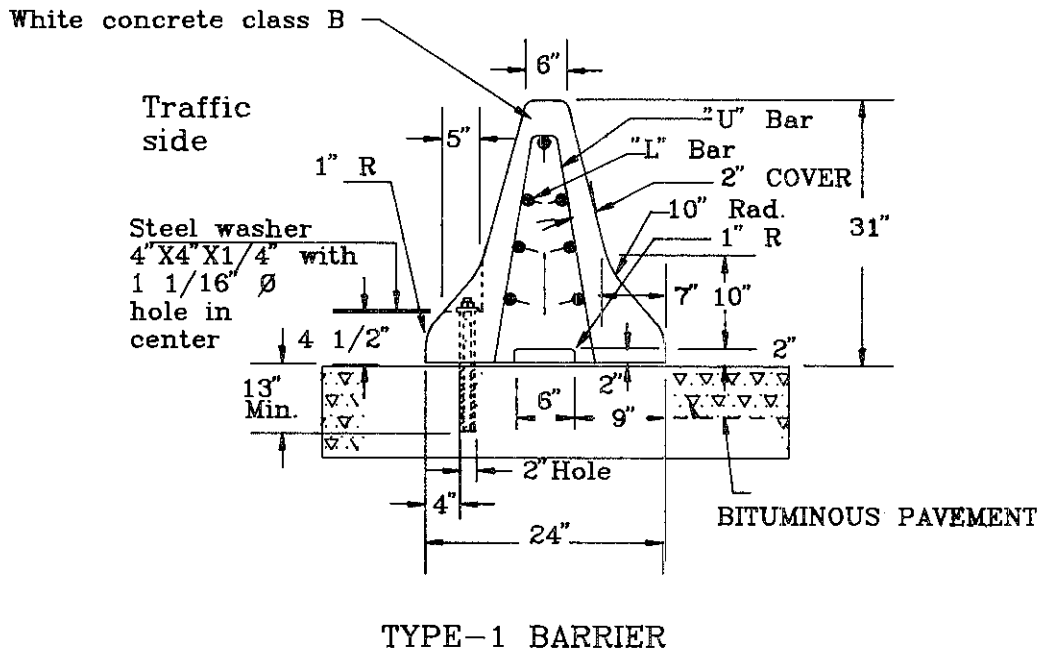
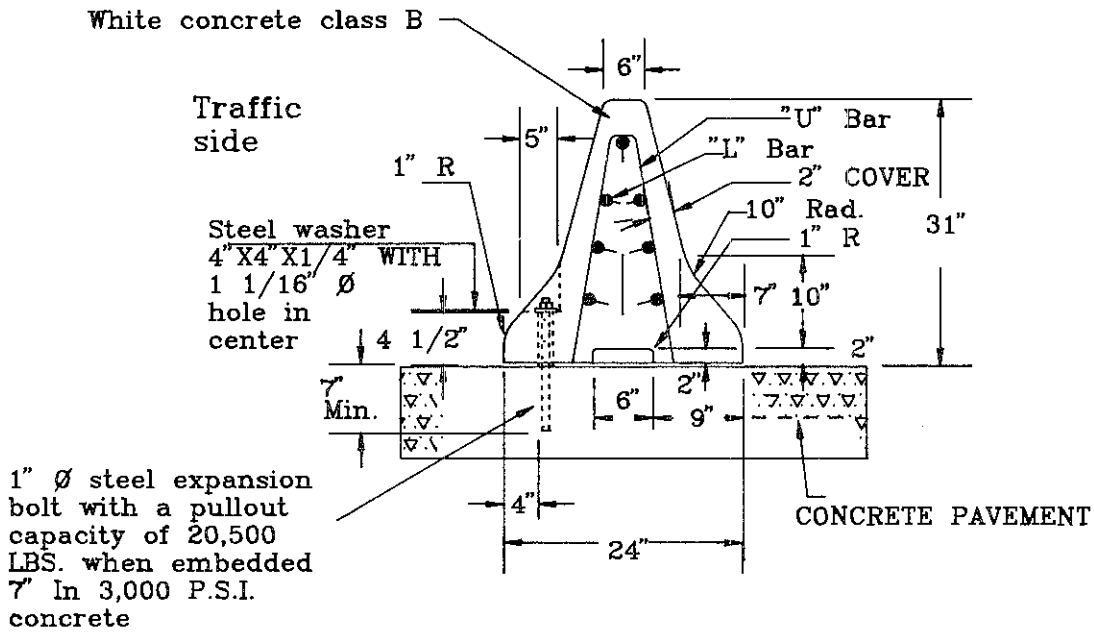

Source: New Jersey Department of Transportation

Figure 29. Design of New Jersey's barrier anchoring system

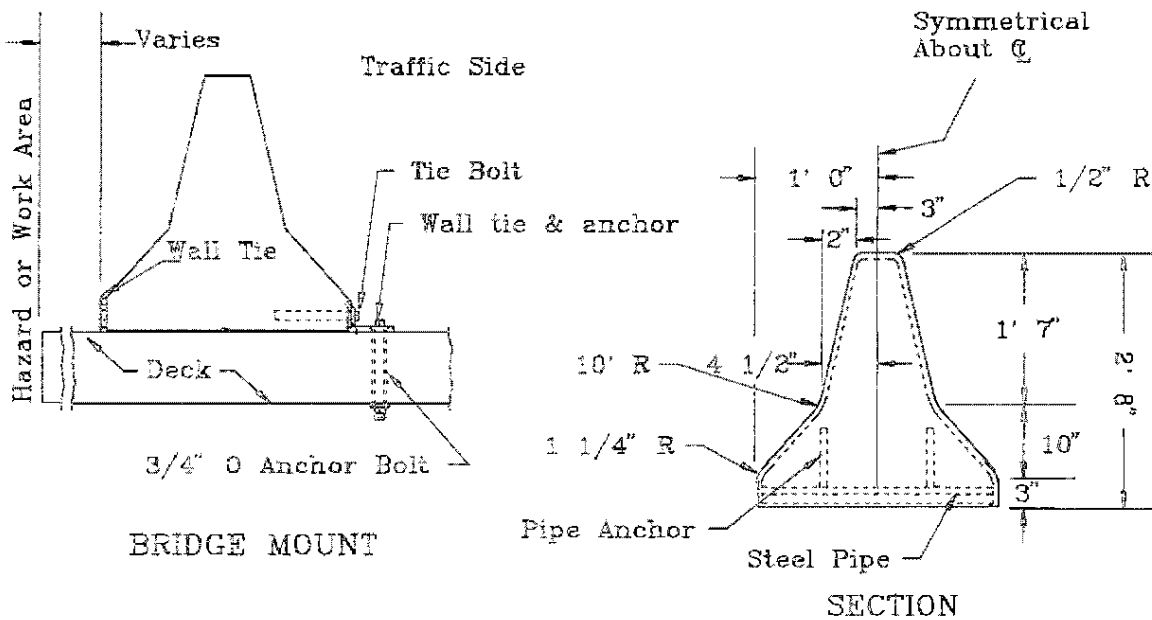

Anchor bolts shall have a pullout and shear capacity of 14,000 lbs. Wedge or chemical anchor bolts may be used in lieu of bolts, washer and nut assembly shown. Core drills shall be used to construct through bolts holes, and, drills specified by the manufacturer shall be used to construct expansion and chemical anchor bolt holes. After removal of walls, anchors shall be removed to 1' min. below deck surface and holes filled with epoxy grout.

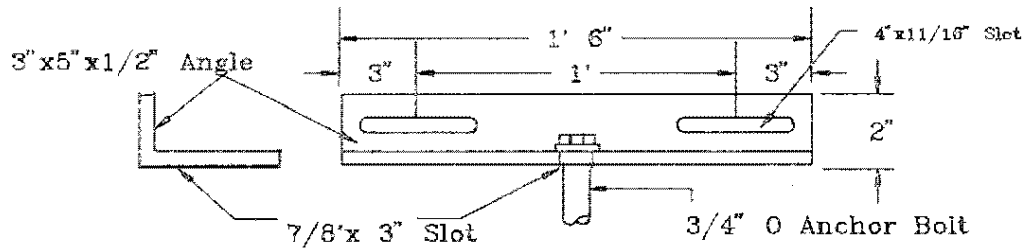

WALL TIE ANCHOR

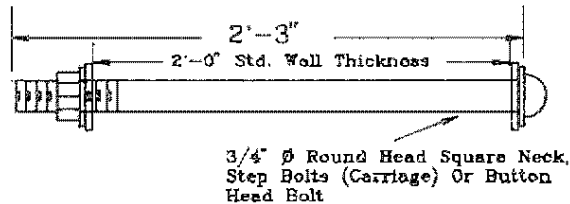

WALL TIE BOLT

Source: Florida Department of Transportation, Roadway Design Standard.

Figure 30. Partial detail of Florida's vertical anchorage for portable CSSBs

IV. ASSESSMENT OF RESEARCH AND PRACTICES

Interest in anchoring portable CSSBs is based on the need to control lateral displacement, tilting, and overturning when impacted by vehicles. Research on horizontal connectors has revealed that tilting and overturning can be partially controlled by strengthening the connectors, inducing tension, and grouting joints. Not all connectors appear suitable for these treatments. The popular tongue and groove, and plate insert connectors, apparently cannot withstand tension, and grouting their joints apparently defeats the purpose of their connector design. Barriers with these connector types need supplementary methods for controlling tilting and lateral displacement. New York's I-beam connector with tension and grouting has been determined to be adequate without anchorage only in situations where the available space for barrier displacement is more than 11 inches. California, which uses the pin and loop connector design, has adopted two feet as the minimum available displacement space for using unanchored portable CSSBs. Some states mandate anchorage whenever portable CSSBs are used in long-term work zones on bridges, regardless of the strength capacities of their barriers and connectors. The anchorage methods used in practice can be grouped in the following classifications:

1. Through-bolts, nuts and washers. These are usually one-inch diameter steel bolts inserted in dowel holes through the barrier and the concrete deck. Insertion can be made from above or from below the deck.
2. Slip resistant plates attached to deck. These plates occupy the keyway below the barrier and are used only to control sliding; i.e., in situations where tilting is improbable.
3. Berm behind barrier. Depending on their height and length, these berms can control both tilting and lateral displacement. Those used in practice are usually less than six inches high and are primarily for restricting sliding. Berms are made of asphalt, dirt, or aggregate.
4. Connecting anchor plates. This method involves side connecting plates which accommodate at least one bolt for attaching the plate to the pavement at the base of joints.
5. Anchor plate with through-bolts, washers and nut. This method utilizes a plate which fits the angles at the base of the barrier and its interface with the pavement (Figure 22). One-through bolt (1 1/4-inch

diameter) and nut are used to anchor each plate to the pavement. Attachment of the plate to the barrier is accomplished with a bolt and resin embedment.

6. Bolts and resin embedment. Bolts are inserted through vertical holes in the barrier and are screwed into grouted anchor nuts embedded in the pavement.
7. Dowel pins. Headless pins, usually made of No. 8 rebar, are inserted through vertical holes in the barrier and are embedded with resin into the pavement.
8. Pavement pins. These are headless pins which are inserted into dowel holes in the pavement along the side of the barrier not exposed to traffic.

The more popular connectors (pin and loop, tongue and groove, and plate insert) used on portable CSSBs have not been subject to controlled crash testing to assess the minimum tension and shear capacity for their respective anchoring systems. There is limited research on vertical anchorage and the limited experimentation that has been conducted (2) clearly indicates the potential for large lateral movements at impact and for the failure of studs or anchor bolts which are less than 0.75 inches in diameter, depending upon their spacing. The bulk of the crash tests on portable CSSBs did not employ vertical anchorage. However, their results can still be examined to determine the range of moments that must be accommodated (based on the type of connectors, impact speed, impact angle, and barrier lengths) in the design of vertical anchorage. At least one state, Ohio, has already done this, and Pennsylvania is about to follow suit.

Officials from the eight states visited recognize the need to anchor portable CSSBs. The diversity in barrier designs, horizontal connectors, and barrier lengths has resulted in an equivalent diversity in anchorage characteristics and types and in the judgment of state officials interviewed. Most of the states have not experienced a sufficient number of the type of accidents which would challenge the limits of their anchoring system, and thus, they have no reason to suspect that their system is inadequate. The occasional accident involving a heavy vehicle is viewed as an exceptional case where anchorage may fail.

It is instructive to note that the 1 to 1.25-inch diameter bolts and pins used for barrier anchorage can provide adequate tension and shear capacity of 36,000 and 22,000 pounds per square inch, respectively. Construction engineers in Pennsylvania and Maryland are satisfied with such bolts. However, it must be recognized that all the primary components of the entire system -- bolts, nuts, embedment resin, pavement

concrete, and barrier concrete -- are potential areas for failure. Thus a structured approach to the design of an anchoring system is necessary in order to ascertain the true nature of a failure. Isolated cases of conical failure of the barrier and pavement concrete with anchor bolts intact and failure of the grouting resin have been experienced in one state. This failure of a barrier system which utilized bolts and nuts indicates that those barriers which rely only on anchor pins are generally less reliable, although it may be argued that the more robust connectors (New York's I-beam, for example) could demand lower capacities, in shear and tension, of anchoring components.

Some officials are concerned with the potential for improper installation of anchor units on long bridges. Although specifications may prescribe the procedures for preparing dowels for resin anchorage, officials express concern that once the bolts are anchored in the resin it is impractical to test their pullout capacity. The use of through-bolts with nuts and washers could eliminate some fears about system failure due to faulty workmanship. However, construction contractors in at least one state favor less labor intensive methods which do not require access below the deck for installing anchor bolts and nuts. Resin anchors applied to portable CSSBs on bridges remain a subject of concern.

Since there is so much variation in the design of barriers, anchorage, and connectors, the identification of the best anchorage can only be determined through detailed structural analysis and, preferably, with actual crash testing. However, based on barrier behavior during past crash tests, and discussions with field engineers, anchorage using through-bolts (one-inch diameter minimum), nuts, and washers or plates and through-bolts appear to be more capable of resisting shear, tension, and conical pullout failures, as well as reducing the potential for improper installation of bolts since the use of resin anchors will be limited.

In general, the design standards of the states visited do not specify the moment capacity of anchoring devices for portable CSSBs. Officials of the states visited which use anchor bolts believe that the moment forces generated by impacting vehicles are converted into tension forces which must be resisted by the bolts.

V. CONCLUSIONS

- A. Nine of the ten states studied anchor portable CSSBs in work sites where they are needed, and where there is inadequate space behind them to accommodate energy-absorbing displacement without endangering drivers and workers. Selected anchoring devices are designed to control tilting, overturning, and sliding of barriers. Bridge construction, dropoffs close to edge of barriers, and barrier chains which cannot be interconnected because of sharp curves are common situations where vertical anchorage or slide prevention devices are used by the states interviewed.
- B. The minimum desirable space behind portable CSSBs is a factor in anchorage determination, but this measure has not been determined for the majority of barrier and connector designs used today. Uncertainty in the behavior of portable CSSBs when impacted by vehicles in work zones with restricted conditions is the primary reasons why nine of the ten states contacted use some form of vertical anchorage or slide prevention device.
- C. Given the variety of barrier designs, connectors, pavement, and anchors, and that uniformity may not be practical, there is need to develop performance specifications for anchoring systems. These specifications should be based on the individual design details of each barrier and connector group, but with the consideration that all connectors of a certain class do not provide identical performance; for example, all pin and loop connectors may not exhibit identical performance under similar conditions.
- D. Based on discussions with field officials in Pennsylvania, displacements reported in crash test reports, and field observations of anchored portable CSSBs, anchorage on the traffic side using a system of through-bolts, vertical dowels through barriers, nuts, plates, and washers appears to be the preferred practice for long-term work on bridges.

VI. RECOMMENDATIONS

- A. The AASHTO Roadside Design Guide (RDG) (21) should discuss the need to anchor portable CSSBs and offer situations where anchorage should be considered. The RDG should also advise on anchor treatments (with design details) to control sliding, tilting, and overturning. Current practice already substantiates the need for anchorage.
- B. There is need for research on the behavior of anchored portable CSSBs during highway accidents. Of interest is the performance of the anchorage. Apparently, this type of information is excluded from accident reports but is valuable in identifying adequate and inadequate anchor designs. Field officials are an untapped resource for this type of information.
- C. There is need for research to develop performance standards for anchoring systems and to identify the current anchoring systems which satisfy the standards.
- D. Until the results of anchor research are available, practitioners should use anchoring systems which utilize dowel holes in barriers, through-bolts, nuts, washers, and plates instead of pins for anchoring portable CSSBs on bridges.

LIST OF REFERENCES

1. American Concrete Pavement Association, Concrete Safety Barrier and Curb Manual, Arlington Heights, Illinois.
2. Wiles, E. O. and Bronstad, M. E., Temporary Barriers in Construction Zones, Interim Report, Prepared by Southwest Research Institute for Federal Highway Administration, Washington, D.C., August 1976.
3. Bronstad, M. E., and Kimball, C. E., "Crash Test Evaluation of a Precast Interlocked Median Barrier," Project No. 03-3777-002, Southwest Research Institute, San Antonio, Texas, August 1974.
4. Robertson, R. G., Barriers in Construction Zones, Volume 2: Appendix A, Report No. FHWA/RD-86/093, Federal Highway Administration, Washington, D.C., April 1985.
5. Ivey, D. L. et al., Barriers in Construction Zones, Volume 1: Summary Report, Report FHWA/RD-86-092, Federal Highway Administration, Washington, D.C., April 1985.
6. Ivey, D. L. et al., Barriers in Construction Zones - The Response of Atypical Vehicles During Collisions with Concrete Median Barriers, Volume 4, Report No. FHWA/RD-86/095, Federal Highway Administration, Washington, D.C., April 1985.
7. Ivey, Don L. et al., "Portable Median Barriers: Structural Design and Dynamic Performance," Transportation Research Record No. 769, Transportation Research Board, Washington, D.C., 1980.
8. Graham, J. L., Loumiet, J. R. and Migletz, J., Portable Concrete Barrier Connectors, Report No. FHWA TS-88-006, Federal Highway Administration, Washington, D.C., June 1987.
9. Institute of Transportation Engineers, "Portable Concrete Barrier Connectors," ITE Journal Vol. 58, No. 4, April 1988.
10. West Virginia Department of Highways, Current Practices in the Use of Temporary Concrete Barriers, Traffic Engineering Division, Charleston, West Virginia, November 1980.
11. Parks, D. N., Stoughton, R. L., Parker, J. R. and Mordlin, E. F., Vehicle Crash Tests of Unanchored Safety-Shaped Precast Concrete Median Barriers with Pinned End Connections, Report No. CA-DOT-TL-6624-1-76-52, California Department of Transportation, Sacramento, August 1976.

12. Parks, D. M., Stoughton, R. L., Stoker, J. R. and Nordlin, F. P., Vehicle Crash Test of A Continuous Concrete Median Barrier Without A Footing, Report No. FHWA-CA-TL6883-772-22, California Department of Transportation, Sacramento, California, August 1977.
13. Lisle, F. N. and Hargroves, B. T., Evaluation of the Performance of Portable Precast Concrete Traffic Barriers, Report No. VHTRC 79-R29, Virginia Highway and Transportation Research Council, Charlottesville, Virginia, November 1978.
14. Hahn, K. C. and Bryden, J. E., "Crash Test of Construction-Zone Traffic Barriers," Transportation Research Record No. 769, Transportation Research Board, Washington, D.C., 1980.
15. Hahn, K. C. and Bryden, J. E., Crash Test of Construction Zone Traffic Barriers, Report No. FHWA/NY/RR-80-82, Federal Highway Administration, Washington, D.C., June 1980.
16. Fortuniewicz, J. S., Bryden, J. E. and Phillips, R. G., Crash Tests of Portable Concrete Median Barrier for Maintenance Zones, New York State Department of Transportation, Engineering Societies Library, New York, December 1982.
17. Bureau of Highway Design, Standards for Roadway Construction, Commonwealth of Pennsylvania Department of Transportation, Harrisburg, Pennsylvania, May 1983.
18. Marcum, Adam J., Design and Evaluation of Temporary Precast Concrete Barriers for Use on Ohio Bridge Decks, Ohio Department of Transportation, Columbus, Ohio, 1988.
19. Marcum, Adam J., Guide for Installing Temporary Precast Concrete Barriers on Ohio Bridge Decks, Ohio Department of Transportation, Columbus, Ohio, June 1988.
20. U.S. Department of Transportation, Manual on Uniform Traffic Control Devices, Federal Highway Administration, Washington, D.C., July 1978.
21. American Association of State Highway and Transportation Officials, Roadside Design Guide, March 1989.

APPENDIX

STATE OF OHIO
DEPARTMENT OF TRANSPORTATION
DESIGN DEVELOPMENT ADMINISTRATION
BUREAU OF BRIDGES AND STRUCTURAL DESIGN

August 8 , 1988

MEMO TO: Bureau Chiefs, District Deputy Directors, County
Engineers and Consulting Engineers

FROM: B.D. Hanhिलammi, Engineer of Bridges and Structural
Design

BY: Walter T. Florence, Assistant Engineer of Bridges

SUBJECT: Guide for Installing Temporary Precast Concrete
Barriers on Ohio Bridge Decks

Transmitted herewith is the above referenced manual to be used to
determine the following:

1. What modifications to make to Ohio's existing
temporary precast concrete barrier (Standard
Construction Drawing MC-9A) to qualify it for
use on specific bridge decks.
2. Steps to be considered in the design of new
(proposed replacement) temporary precast concrete
barrier for use on bridge decks.
3. Methods of installation and/or anchorage to be
used in securing both types of temporary precast
concrete barrier on bridge decks.

Barrier use determination is based upon the concept of probable im-
pact severity.

WTF
BDH:WTF:ser
Attachment

GUIDE FOR INSTALLING TEMPORARY
PRECAST CONCRETE BARRIERS
ON OHIO BRIDGE DECKS

by Adam J. Marcum

OHIO DEPARTMENT OF TRANSPORTATION
BUREAU OF BRIDGES AND STRUCTURAL DESIGN

REVISIONS	STATE OF OHIO DEPARTMENT OF TRANSPORTATION BUREAU OF BRIDGES AND STRUCTURAL DESIGN
	APPROVED: <u>6-30-88</u> DATE <u>B. D. Hamilton</u> ENGINEER OF BRIDGES

TABLE OF CONTENTS

NOTICE.....1

BACKGROUND.....2

USE OF THE EXISTING OHIO BARRIER.....2

THE PROPOSED OHIO BARRIER.....2

BRIDGE DECK SURFACE PREPARATION.....3

FIGURE 1 - MODIFIED (EXISTING) BARRIER DETAILS.....4

FIGURE 2 - PROPOSED BARRIER DETAILS.....5

FIGURE 3 - PROPOSED BARRIER DETAIL AT HINGED CONNECTION.....6

FIGURE 4 - JOINT CONNECTION DETAILS.....6

BARRIER ANCHORAGE REQUIREMENTS.....7

FIGURE 5 - IMPACT SEVERITY VS ROADWAY WIDTH.....8

FIGURE 6 - PLACEMENT VS IMPACT SEVERITY
OF AN UNANCHORED BARRIER CHAIN
COMPOSED OF 10' LONG SEGMENTS.....8

FIGURE 7 - ANCHORS REQUIRED PER 10' BARRIER SEGMENT
FOR MODIFIED (EXISTING) BARRIER CHAINS.....9

FIGURE 8 - ANCHORS REQUIRED PER 10' BARRIER SEGMENT
FOR PROPOSED BARRIER CHAINS.....9

NOTICE:

THE CONTENTS OF THIS GUIDE REFLECTS THE VIEWS OF THE PREPARER AND THE BUREAU OF BRIDGES AND STRUCTURAL DESIGN WHICH IS RESPONSIBLE FOR THE ACCURACY OF THE DATA PRESENTED HEREIN. THE GOAL OF THIS GUIDE IS TO ESTABLISH A UNIFORM DESIGN POLICY FOR THE INSTALLATION OF TEMPORARY PRECAST CONCRETE BARRIERS ON OHIO BRIDGE DECKS. THIS GUIDE IS INTENDED FOR THE PRIVATE USE OF THE OHIO DEPARTMENT OF TRANSPORTATION, BUREAU OF BRIDGES AND STRUCTURAL DESIGN AND THEIR AGENTS. THE INFORMATION CONTAINED HEREIN IS SUBJECT TO PERIODIC REVIEW AND/OR REVISION BY THE ISSUING AUTHORITY. THEREFORE, IT SHALL BE THE DUTY OF THE DESIGNER, TO ENSURE THAT HIS IS THE LATEST INFORMATION AVAILABLE. THIS GUIDE SHOULD ONLY BE REPRODUCED AS A WHOLE. ANY COPYING OR DISTRIBUTION OF INDIVIDUAL PAGES IS TO BE DISCOURAGED.

BACKGROUND:

THIS GUIDE HAS BEEN COMPILED USING THE INFORMATION WHICH WAS GATHERED AND/OR GENERATED DURING THE PREPARATION OF THE REPORT, "DESIGN AND EVALUATION OF TEMPORARY PRECAST CONCRETE BARRIERS FOR USE ON OHIO BRIDGE DECKS". COPIES OF THIS REPORT ARE AVAILABLE FROM THE OHIO DEPARTMENT OF TRANSPORTATION, BUREAU OF BRIDGES AND STRUCTURAL DESIGN. ONLY BOLT CONNECTED BARRIER DESIGNS ARE TO BE USED IN CONJUNCTION WITH THIS GUIDE. THE USE OF PIN CONNECTED OR TONGUE AND GROOVE BARRIER DESIGNS SHALL NOT BE PERMITTED ON OHIO BRIDGE DECKS.

USE OF THE EXISTING OHIO BARRIER:

BECAUSE OF THE INHERENT WEAKNESS OF THE EXISTING OHIO BARRIER (STANDARD CONSTRUCTION DRAWING MC-9A, REVISED 1-11-85, CONNECTING PIN TYPE), EVEN WHEN MODIFIED, CARE MUST BE TAKEN BY THE DESIGNER WHEN SPECIFYING ITS USE IN AREAS OF PROBABLE HIGH IMPACT SEVERITY (OVER 45,000 FT-LBS). THE MODIFICATIONS TO BE MADE TO THE EXISTING BARRIER, PRIOR TO ITS USE ON OHIO BRIDGE DECKS, ARE LISTED BELOW AND SHOWN IN FIGURES 1 ON PAGE 4. USE FIGURE 5, PAGE 8, TO DETERMINE THE IMPACT SEVERITY.

1. REPLACE CONNECTION PINS WITH 1 1/4 INCH DIA. HIGH STRENGTH BOLTS.
2. FURTHER STIFFEN THE CONNECTION, WHERE REQUIRED *, BY FASTENING AN ANGLE (4"X 4"X 3/4") TO THE BACK FACE OF JOINT.
3. LIMIT THE SLACK IN JOINTS BETWEEN SEGMENTS TO A MAXIMUM OF 3 DEGREES BY SHIMMING AND/OR GROUTING THE JOINT.

* WHEN THE EXISTING BARRIER IS USED IN AREAS OF LOW TO MODERATE IMPACT SEVERITY (30,000 FT-LBS OR LESS) THE STEEL ANGLE MAY GENERALLY BE OMITTED, SEE FIGURE 5, PAGE 8.

THE PROPOSED OHIO BARRIER:

THE EXISTING BARRIER HAS DRAWBACKS, AS STATED ABOVE, THAT TEND TO RESTRICT ITS USE ON BRIDGE DECKS. CORRECTING THESE FAULTS, IN ORDER TO PROVIDE A MORE CRASH-WORTHY BARRIER, WOULD NECESSITATE THE FOLLOWING ACTIONS:

1. THE STEEL ROD CONNECTOR LOOPS (HINGE BARS) SHOULD BE GRADE 60, MINIMUM YIELD STRENGTH OF 60,000 PSI, WITH INCREASED EMBEDMENT.
2. THE CONCRETE USED SHOULD HAVE A MINIMUM COMPRESSIVE STRENGTH OF 4,000 PSI.

3. THE BARRIER SEGMENT MUST BE REINFORCED USING GRADE 60 REINFORCING STEEL. (THE PRESENT DESIGN ALLOWS FABRICATION WITH LITTLE OR NO REINFORCING.)
4. THE JOINT SLACK (THE DEGREE OF HORIZONTAL JOINT ROTATION) SHOULD BE REDUCED FROM ITS PRESENT VALUE OF 8 DEGREES, DOWN TO A MAXIMUM OF 3 DEGREES.

WHEN THE ABOVE CHANGES HAVE BEEN INCORPORATED INTO A NEW PRECAST BARRIER DESIGN, IT SHOULD MEET ALL OF THE EXISTING REQUIREMENTS FOR TEMPORARY PRECAST CONCRETE BARRIERS. THESE NEW BARRIER SEGMENTS SHALL BE PERMANENTLY MARKED, FOR IDENTIFICATION PURPOSES, WITH AN APPROVED CODE SUCH AS "BRD-XX" (WHERE XX = THE YEAR CAST). FOR DETAILS OF ONE SUCH PROPOSED BARRIER DESIGN, SEE FIGURE 2, PAGE 5, OF THIS GUIDE. THE DESIGNER MAY USE THIS BARRIER, OR ONE OF A SIMILAR DESIGN AS APPROVED BY THE DIRECTOR. ALL DESIGNS SHALL MEET OR EXCEED THE DESIGN REQUIREMENTS DESCRIBED IN THE REPORT, "DESIGN AND EVALUATION OF TEMPORARY PRECAST CONCRETE BARRIERS FOR USE ON OHIO BRIDGE DECKS". DESIGNS, AS SUBMITTED, SHALL BECOME THE PROPERTY OF THE STATE OF OHIO.

BRIDGE DECK SURFACE PREPARATION:

THE PROCEDURES WHICH MUST BE FOLLOWED, WHEN INSTALLING ALL TEMPORARY PRECAST CONCRETE BARRIERS ON OHIO BRIDGE DECKS, ARE GIVEN BELOW.

- A. THE BRIDGE DECK SURFACE AREA ON WHICH THE PRECAST CONCRETE BARRIERS WILL REST, SHALL BE CLEARED OF ALL LOOSE SAND, GRAVEL, DIRT AND DEBRIS.
- B. ANY IRREGULARITIES IN THE BRIDGE DECK AREA, UNLESS JUDGED BY THE ENGINEER TO BE INCONSEQUENTIAL, SHALL BE LEVELED WITH GROUT AND/OR ASPHALT.
- C. ASPHALT ROLL ROOFING SHALL BE PLACED ON THOSE BRIDGE DECK AREAS, AS JUDGED BY THE ENGINEER, TO HAVE A SURFACE ROUGHNESS WHICH WOULD INHIBIT FRICTION CONTACT BETWEEN BARRIER SEGMENTS AND DECK.

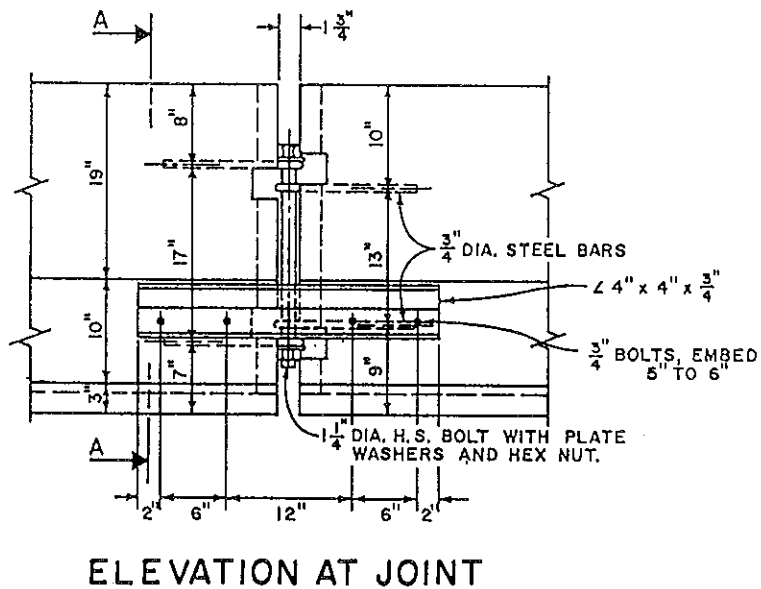
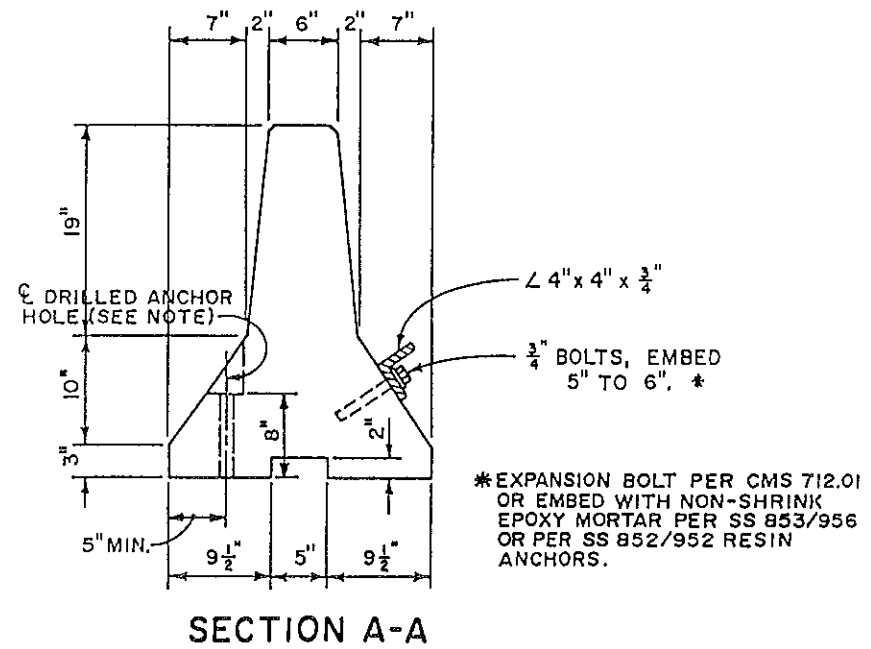
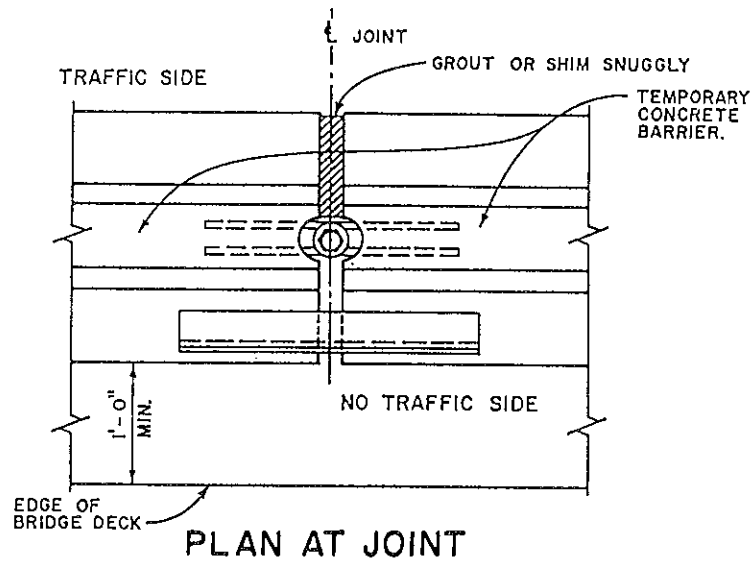

NOTES:

IN ORDER TO ANCHOR THE MODIFIED (EXISTING) BARRIER TO THE BRIDGE DECK, WHERE ANCHORING IS REQUIRED, 1-1/4" MIN. DIAMETER HOLES MUST BE DRILLED THROUGH THE BARRIER TOE AT THE LOCATION SHOWN IN THE ABOVE SECTION. GREAT CARE MUST BE USED IN DRILLING AND INSTALLING THE BARRIER SEGMENTS, AS ANY DAMAGE TO THEM WILL BE CONSIDERED CAUSE FOR THEIR REJECTION.

ALL ANCHORS SHALL BE 1" DIAMETER, HIGH STRENGTH, THRU BOLTS OR APPROVED RESIN ANCHORS. WHEN RESIN ANCHORS ARE USED, THEY MUST BE EMBEDDED A MINIMUM OF 6" INTO FIRM CONCRETE. THE NUMBER OF ANCHORS SHALL BE AS DETERMINED BY FIGURE 7, PAGE 9.

FIGURE 1 - MODIFIED (EXISTING) BARRIER DETAILS

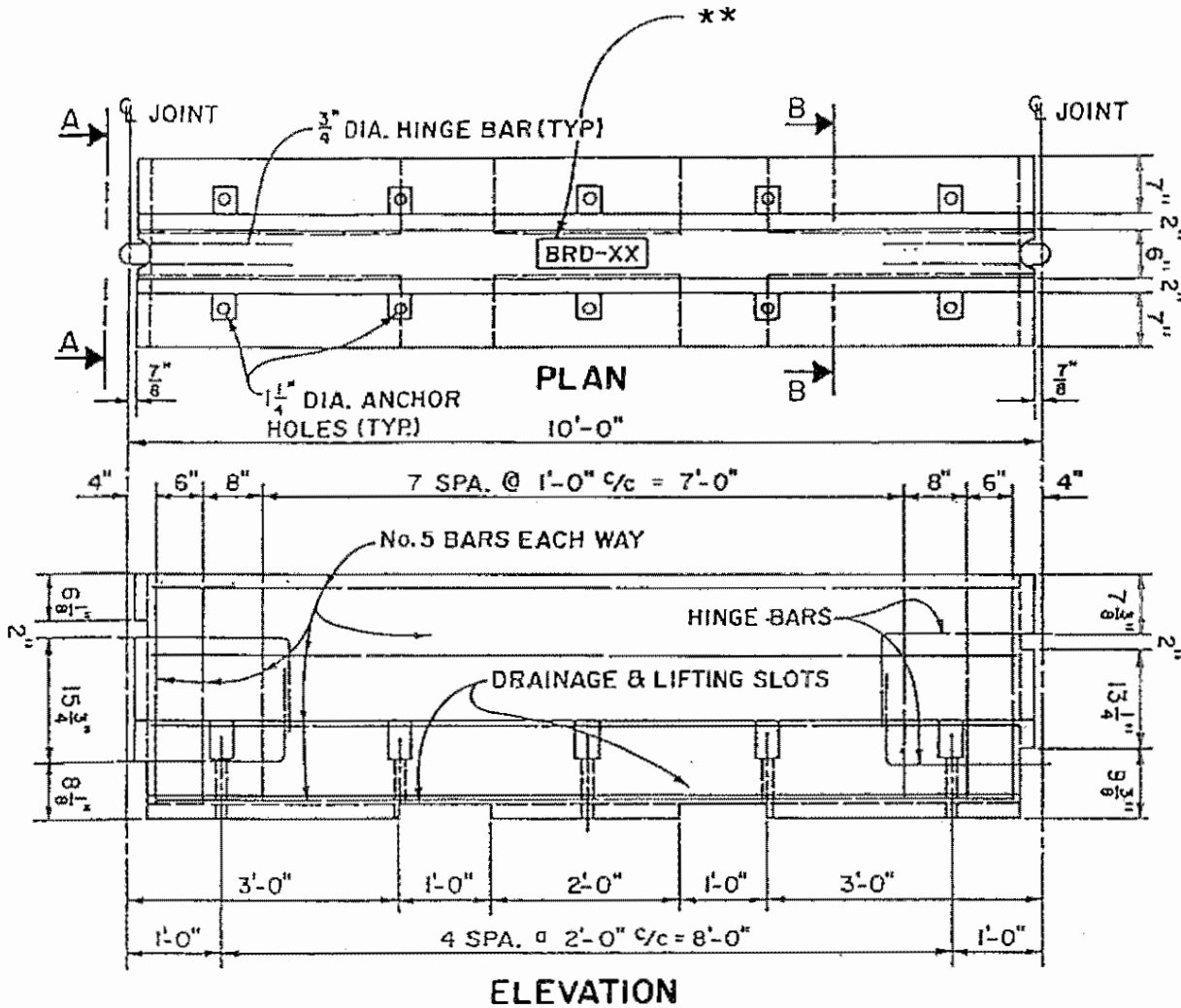

** ALL NEW BARRIER SEGMENTS MADE ACCORDING TO THE PROPOSED DESIGN, OR AN APPROVED EQUAL, SHALL BE CLEARLY MARKED, SUCH AS "BRD-XX" (WHERE XX = THE YEAR CAST).

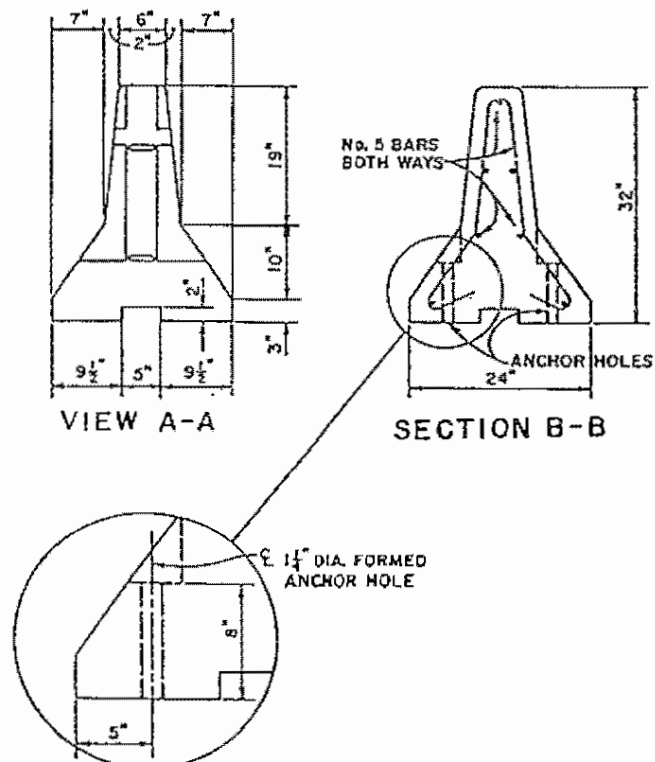

NOTE:
ALL ANCHORS SHALL BE 1" DIAMETER, HIGH STRENGTH, THRU BOLTS OR APPROVED RESIN ANCHORS. WHEN RESIN ANCHORS ARE USED, THEY MUST BE EMBEDDED A MINIMUM OF 6" INTO FIRM CONCRETE. THE NUMBER OF ANCHORS SHALL BE AS DETERMINED BY FIGURE 8, PAGE 9.

FIGURE 2 - PROPOSED BARRIER DETAILS

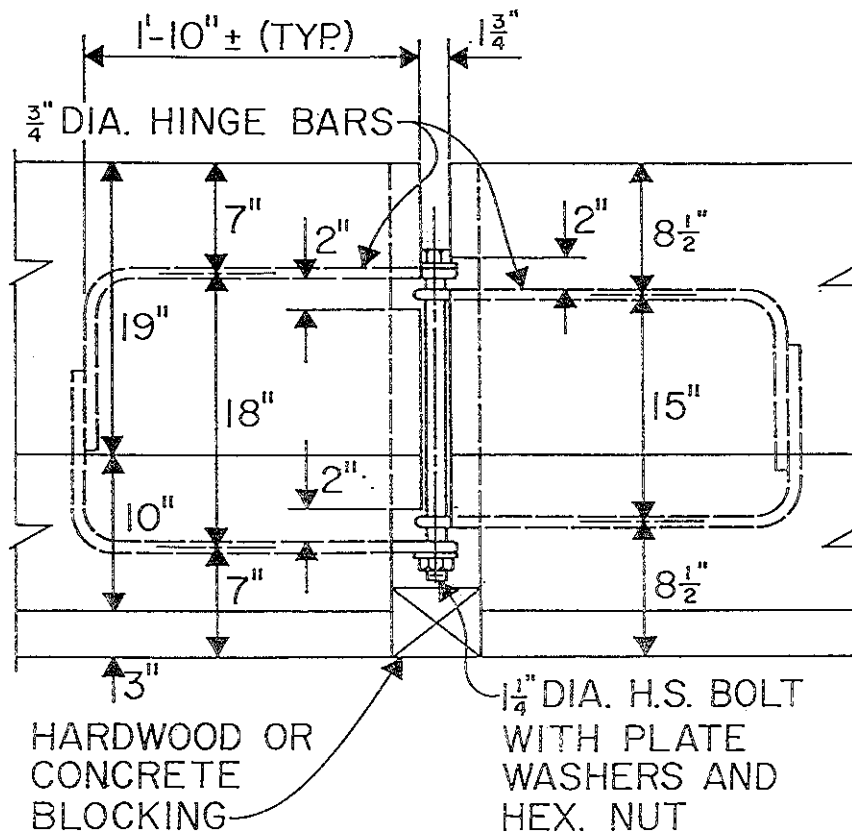
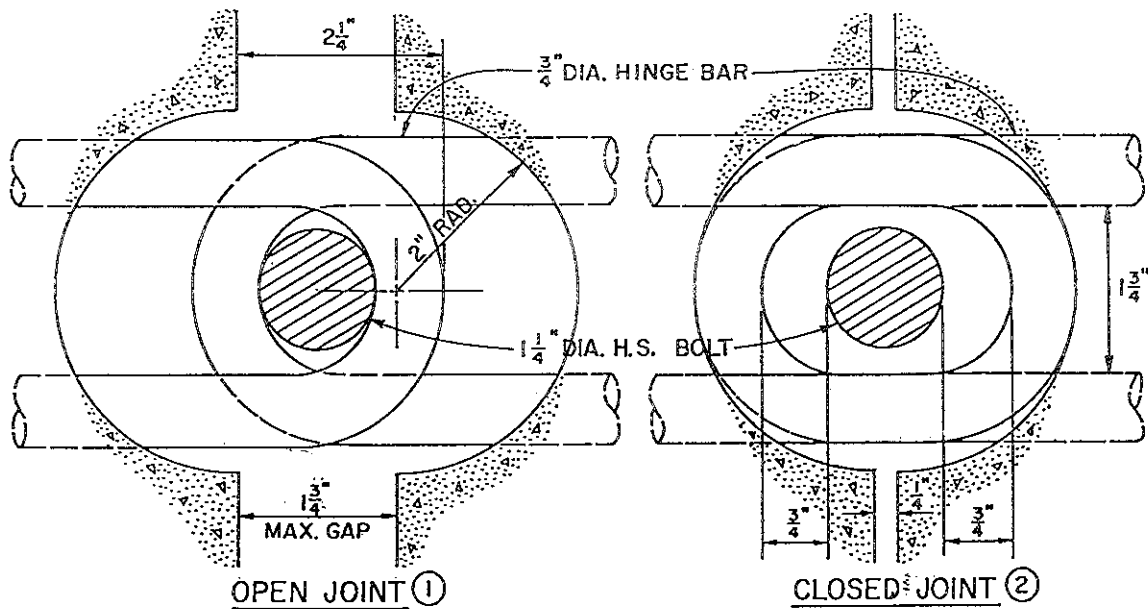

FIGURE 3 - PROPOSED BARRIER DETAIL AT HINGED CONNECTION



① BARRIER JOINTS MUST BE FULLY OPEN BEFORE NUT IS TIGHTENED ONTO BOLT AND OPENING IS EITHER GROUTED OR SHIMMED.

② BARRIERS SHOULD INITIALLY BE PLACED CLOSER TOGETHER SO THAT BOLTS CAN BE EASILY INSERTED THROUGH HINGE BAR LOOPS.

FIGURE 4 - JOINT CONNECTION DETAILS

BARRIER ANCHORAGE REQUIREMENTS:

THE ANCHORAGE REQUIREMENTS FOR TEMPORARY PRECAST CONCRETE BARRIERS CAN BE DETERMINED BY USING THE FOLLOWING PROCEDURES.

1. ENTER FIGURE 7, PAGE 9, WITH THE KNOWN ROADWAY WIDTH AND THE POSTED SPEED LIMIT * AND FIND THE NUMBER OF ANCHORS REQUIRED WHEN THE MODIFIED (EXISTING) BARRIER DESIGN IS USED.

OR

ENTER FIGURE 8, PAGE 9, WITH THE KNOWN ROADWAY WIDTH AND THE POSTED SPEED LIMIT * AND FIND THE NUMBER OF ANCHORS REQUIRED WHEN THE PROPOSED BARRIER DESIGN IS USED.

2. IF THE BARRIER INSTALLATION IS TO REMAIN UNANCHORED, EITHER BECAUSE OF LOW IMPACT SEVERITY OR THE AVAILABILITY OF SPACE BETWEEN THE BARRIER AND THE EDGE OF THE BRIDGE DECK, ENTER FIGURE 5, PAGE 8, WITH THE KNOWN ROADWAY WIDTH AND THE POSTED SPEED LIMIT * AND FIND THE IMPACT SEVERITY. THEN, WITH THE KNOWN IMPACT SEVERITY, ENTER FIGURE 6, PAGE 8, AND FIND THE MINIMUM CLEAR DISTANCE REQUIRED FROM THE EDGE OF THE BRIDGE DECK AT WHICH THE BARRIER (MODIFIED OR PROPOSED) CAN BE LOCATED.

* THE POSTED SPEED LIMIT SHALL BE DEFINED AS THE SPEED THAT IS ACTIVELY ENFORCED EITHER BY LEGAL MEANS OR TRAFFIC CONTROL DEVICES.

ALL BARRIER SEGMENTS SHALL, WHERE REQUIRED, BE FASTENED TO THE BRIDGE DECK USING ONE INCH DIAMETER HIGH STRENGTH THRU BOLTS OR APPROVED RESIN ANCHORS. WHEN RESIN ANCHORS ARE USED THEY MUST BE EMBEDDED A MINIMUM OF 6" INTO FIRM CONCRETE. GENERALLY, ALL ANCHORS SHALL BE PLACED ON THE TRAFFIC SIDE OF THE BARRIER WITH THE ANCHOR PATTERN SYMMETRICAL ABOUT THE CENTER OF EACH TEN FOOT SEGMENT. EVEN THOSE PRECAST CONCRETE BARRIER SEGMENTS NOT OTHERWISE REQUIRING ANCHORING SHALL, WHEN LOCATED ON BRIDGE DECKS CROSSING OVER ROADWAYS, RAILROADS, AND/OR RECREATIONAL AREAS, BE SECURED BY NO LESS THAN TWO ANCHORS **.

** UNLESS BARRIER SEGMENTS ARE TO BE INSTALLED 6 FT. OR MORE (CLEAR DISTANCE) FROM THE EDGE OF DECK, EQUIPMENT, AND/OR PROBABLE WORK AREAS.

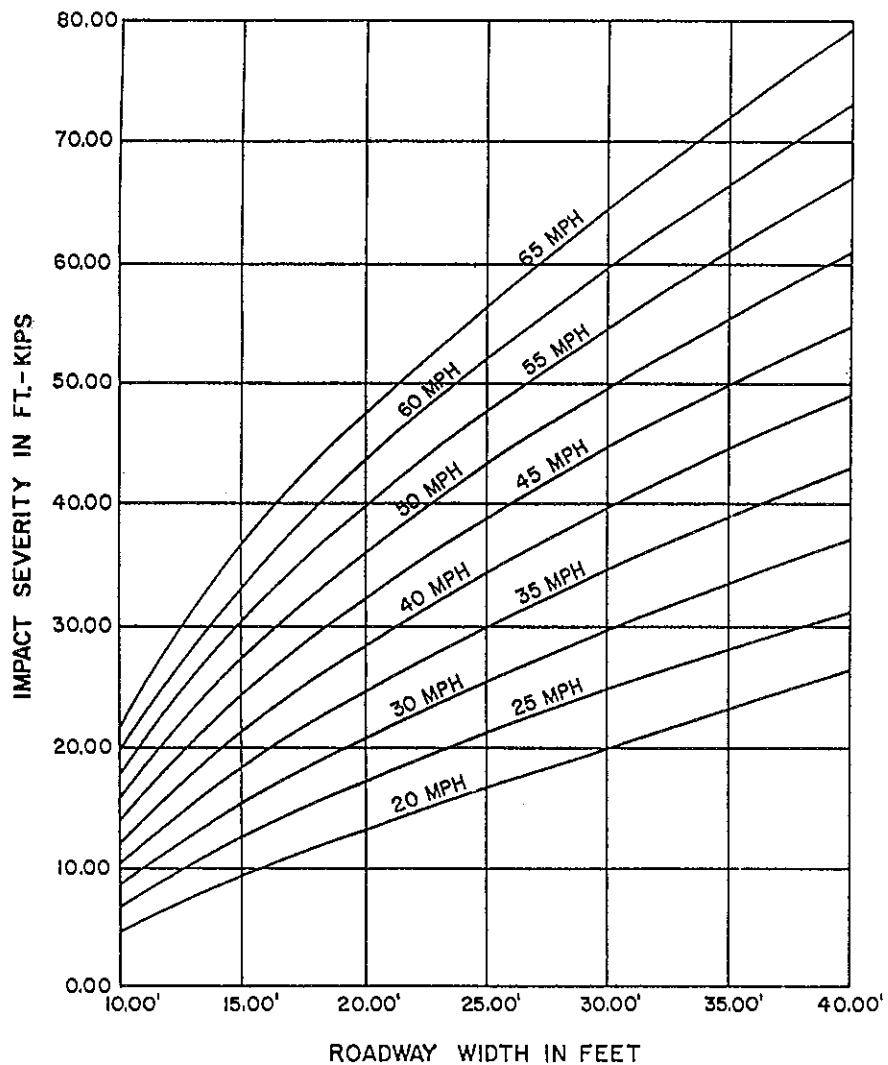

FIGURE 5 - IMPACT SEVERITY VS ROADWAY WIDTH

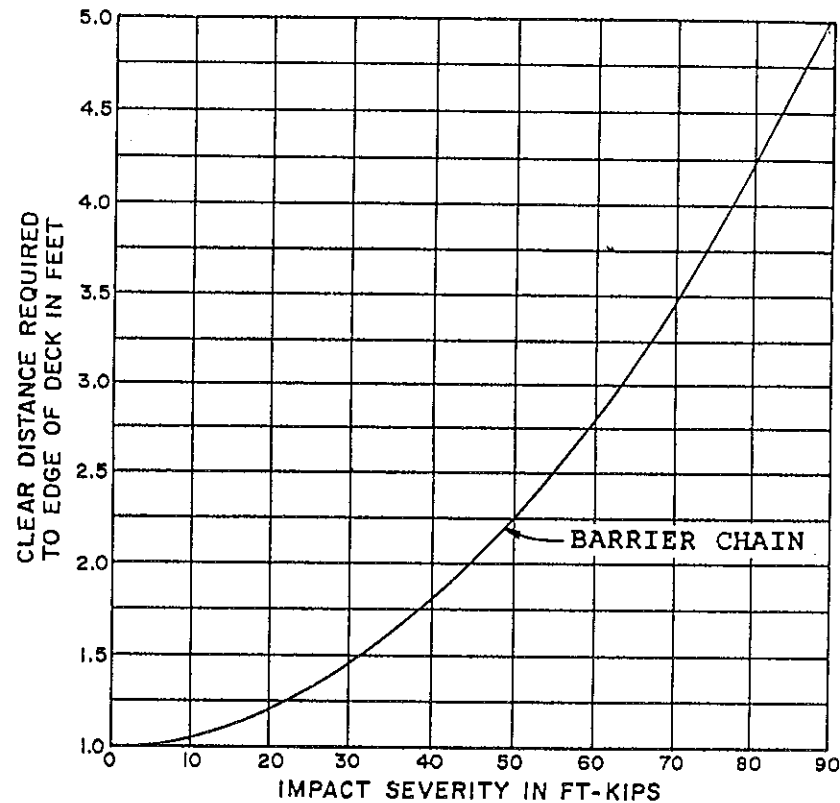

FIGURE 6 - PLACEMENT VS IMPACT SEVERITY OF AN UNANCHORED BARRIER CHAIN COMPOSED OF 10' LONG SEGMENTS

NOTE:

"ROADWAY WIDTH" SHALL BE DEFINED AS THE CLEAR DISTANCE BETWEEN THE TRAFFIC FACE OF THE PRECAST TEMPORARY CONCRETE BARRIER CHAIN AND THE PERMANENT BRIDGE RAILING OR THE FACE OF SIDEWALK OR SAFETY CURB.

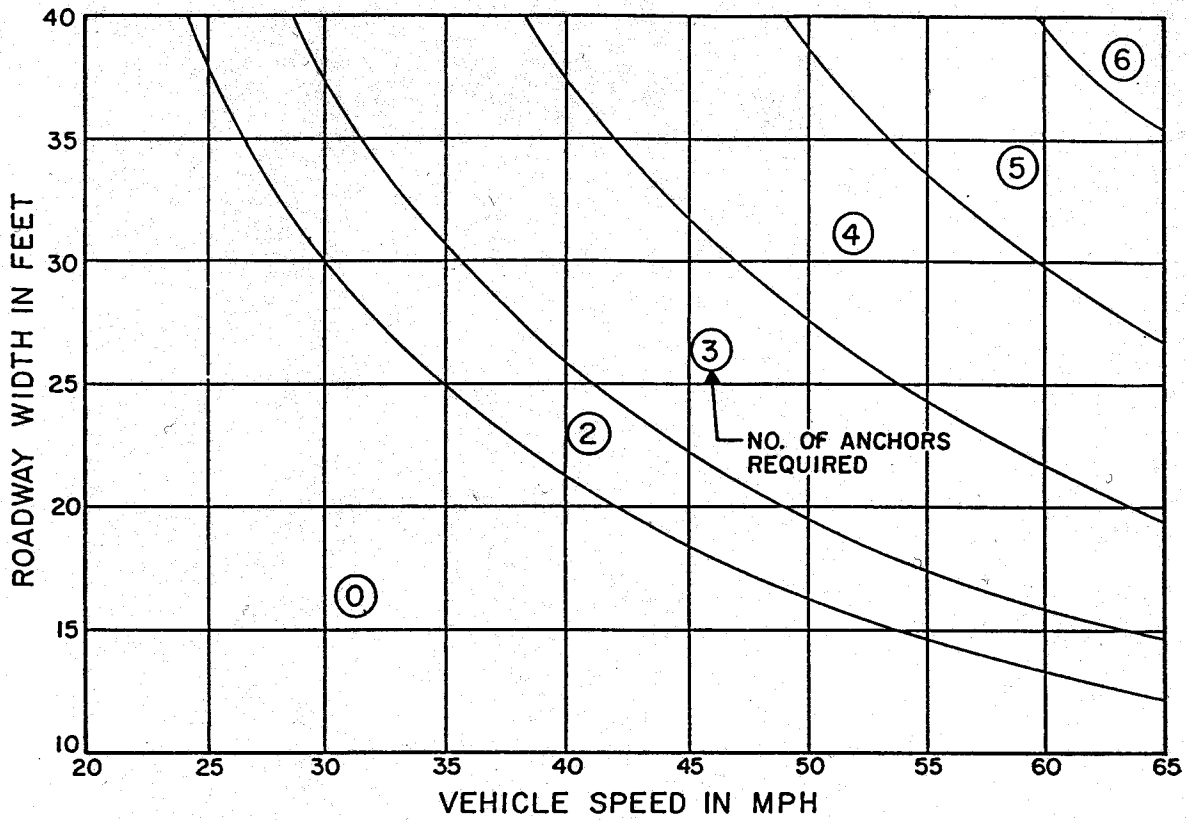

FIGURE 7 - ANCHORS REQUIRED PER 10' BARRIER SEGMENT FOR MODIFIED (EXISTING) BARRIER CHAINS

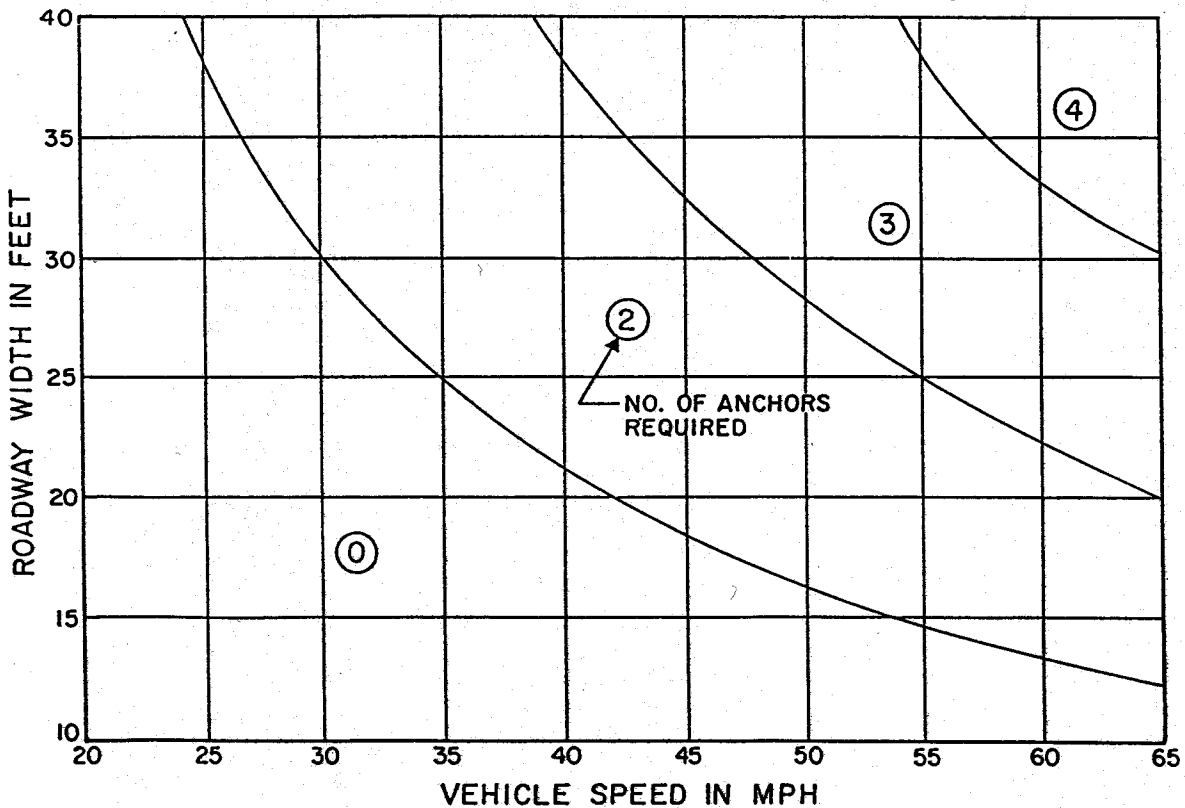

FIGURE 8 - ANCHORS REQUIRED PER 10' BARRIER SEGMENT FOR PROPOSED BARRIER CHAINS