

# Application of the Quality Functional Deployment Method in Mobility Aid Securement System Design

December 1992

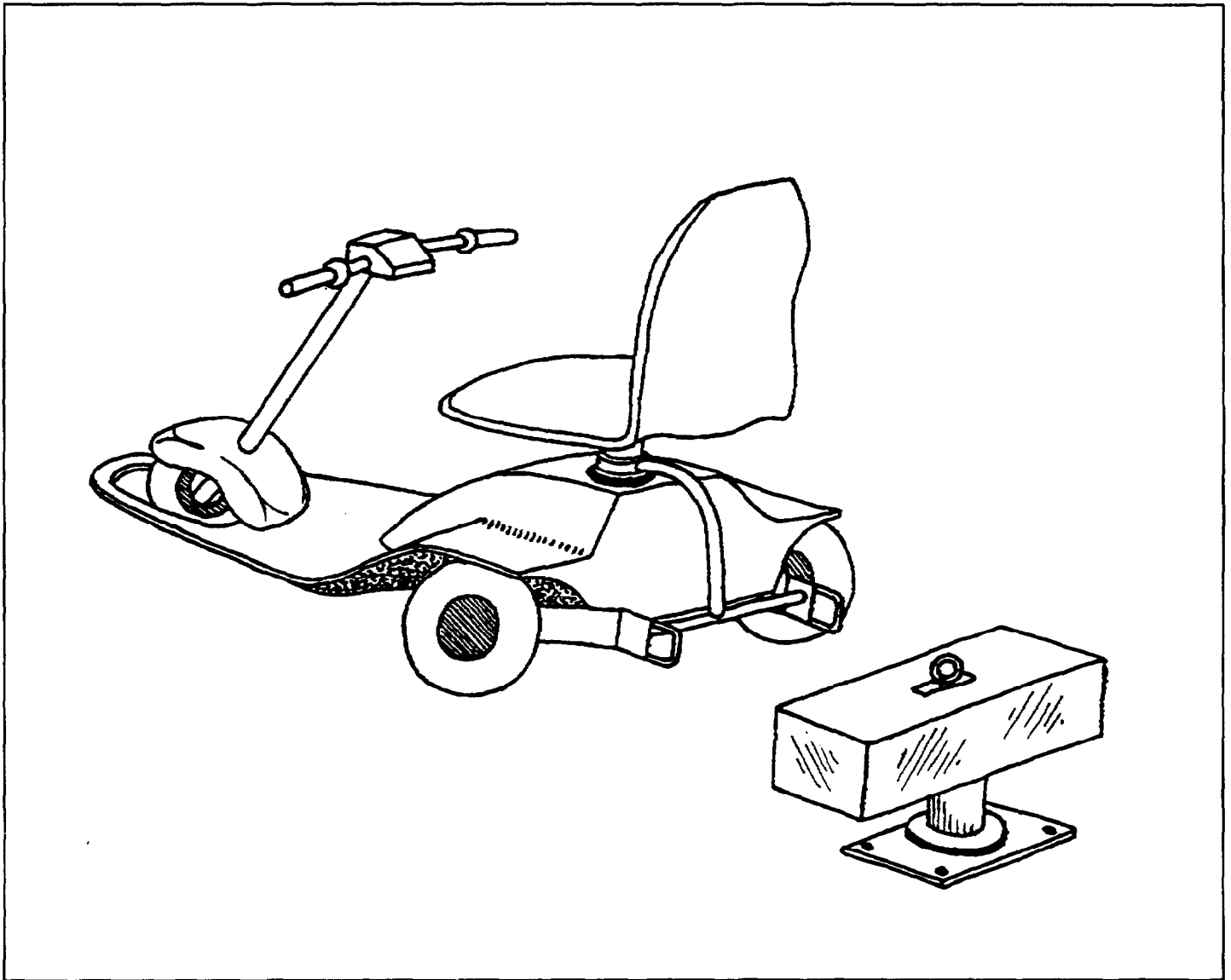

**FEDERAL TRANSIT ADMINISTRATION**



# **Application of the Quality Functional Deployment Method in Mobility Aid Securement System Design**

---

**Final Report  
December 1992**

## **Prepared by**

**Katharine M. Hunter-Zaworski, David G.  
Ullman, and Derald E. Herling  
Transportation Research Institute  
Oregon State University  
Corvallis, Oregon 97331**

## **Prepared for**

**University Research and Training Program  
Office of Technical Assistance  
Federal Transit Administration  
Washington, DC 20590**

## **Distributed in Cooperation with**

**Technology Sharing Program  
U.S. Department of Transportation  
Washington, D.C. 20590**

**DOT-T-93-22**

---

## METRIC / ENGLISH CONVERSION FACTORS

### ENGLISH TO METRIC

#### LENGTH (APPROXIMATE)

1 inch (in) = 2.5 centimeters (cm)  
 1 foot (ft) = 30 centimeters (cm)  
 1 yard (yd) = 0.9 meter (m)  
 1 mile (mi) = 1.6 kilometers (km)

#### AREA (APPROXIMATE)

1 square inch (sq in, in<sup>2</sup>) = 6.5 square centimeters (cm<sup>2</sup>)  
 1 square foot (sq ft, ft<sup>2</sup>) = 0.09 square meter (m<sup>2</sup>)  
 1 square yard (sq yd, yd<sup>2</sup>) = 0.8 square meter (m<sup>2</sup>)  
 1 square mile (sq mi, mi<sup>2</sup>) = 2.6 square kilometers (km<sup>2</sup>)  
 1 acre = 0.4 hectares (he) = 4,000 square meters (m<sup>2</sup>)

#### MASS - WEIGHT (APPROXIMATE)

1 ounce (oz) = 28 grams (gr)  
 1 pound (lb) = .45 kilogram (kg)  
 1 short ton = 2,000 pounds (lb) = 0.9 tonne (t)

#### VOLUME (APPROXIMATE)

1 teaspoon (tsp) = 5 milliliters (ml)  
 1 tablespoon (tbsp) = 15 milliliters (ml)  
 1 fluid ounce (fl oz) = 30 milliliters (ml)  
 1 cup (c) = 0.24 liter (l)  
 1 pint (pt) = 0.47 liter (l)  
 1 quart (qt) = 0.96 liter (l)  
 1 gallon (gal) = 3.8 liters (l)  
 1 cubic foot (cu ft, ft<sup>3</sup>) = 0.03 cubic meter (m<sup>3</sup>)  
 1 cubic yard (cu yd, yd<sup>3</sup>) = 0.76 cubic meter (m<sup>3</sup>)

#### TEMPERATURE (EXACT)

$$[(x - 32)(5/9)]^{\circ}\text{F} = y^{\circ}\text{C}$$

### METRIC TO ENGLISH

#### LENGTH (APPROXIMATE)

1 millimeter (mm) = 0.04 inch (in)  
 1 centimeter (cm) = 0.4 inch (in)  
 1 meter (m) = 3.3 feet (ft)  
 1 meter (m) = 1.1 yards (yd)  
 1 kilometer (km) = 0.6 mile (mi)

#### AREA (APPROXIMATE)

1 square centimeter (cm<sup>2</sup>) = 0.16 square inch (sq in, in<sup>2</sup>)  
 1 square meter (m<sup>2</sup>) = 1.2 square yards (sq yd, yd<sup>2</sup>)  
 1 square kilometer (km<sup>2</sup>) = 0.4 square mile (sq mi, mi<sup>2</sup>)  
 1 hectare (he) = 10,000 square meters (m<sup>2</sup>) = 2.5 acres

#### MASS - WEIGHT (APPROXIMATE)

1 gram (gr) = 0.036 ounce (oz)  
 1 kilogram (kg) = 2.2 pounds (lb)  
 1 tonne (t) = 1,000 kilograms (kg) = 1.1 short tons

#### VOLUME (APPROXIMATE)

1 milliliter (ml) = 0.03 fluid ounce (fl oz)  
 1 liter (l) = 2.1 pints (pt)  
 1 liter (l) = 1.06 quarts (qt)  
 1 liter (l) = 0.26 gallon (gal)  
 1 cubic meter (m<sup>3</sup>) = 36 cubic feet (cu ft, ft<sup>3</sup>)  
 1 cubic meter (m<sup>3</sup>) = 1.3 cubic yards (cu yd, yd<sup>3</sup>)

#### TEMPERATURE (EXACT)

$$[(9/5)y + 32]^{\circ}\text{C} = x^{\circ}\text{F}$$

### QUICK INCH-CENTIMETER LENGTH CONVERSION

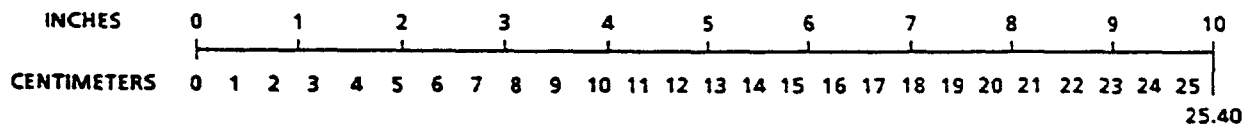

### QUICK FAHRENHEIT-CELCIUS TEMPERATURE CONVERSION

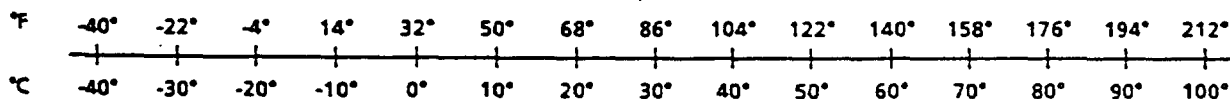

For more exact and/or other conversion factors, see NBS Miscellaneous Publication 286, Units of Weights and Measures. Price \$2.50. SD Catalog No. C13 10 286.



## TABLE OF CONTENTS

	<u>Page</u>
ACKNOWLEDGEMENTS .....	1
CHAPTER 1 — INTRODUCTION .....	3
Introduction .....	3
Report Organization .....	3
Organization of the Volume 1 Report .....	3
Background .....	4
Vocabulary .....	4
Problem Statement .....	5
Research Goals .....	5
Design Objectives .....	6
Project Advisory Committee .....	6
CHAPTER 2 — THE QUALITY FUNCTION DEPLOYMENT METHOD FOR UNDERSTANDING ILL-DEFINED PROBLEMS .....	9
Quality Function Deployment (QFD) .....	9
The QFD Technique: Independent Locking Securement System Application ...	14
CHAPTER 3 — LITERATURE SEARCH .....	19
Literature Search .....	19
Present Technology Survey .....	19
CHAPTER 4 — THE ENGINEERING REQUIREMENTS FOR A SECUREMENT SYSTEM .	21
CHAPTER 5 — BENCHMARK DEVELOPMENTS .....	37
CHAPTER 6 — CONCLUSIONS AND RECOMMENDATIONS .....	43
Value of Method and Results .....	43
Conclusions .....	43
Recommendations .....	44
CHAPTER 7 — REFERENCES .....	45
 APPENDICES	
A    LITERATURE REVIEW: Annotated Bibliography	
B    CURRENT TECHNOLOGY: Securement Systems and Devices	
C    CUSTOMER QUESTIONNAIRE, WEIGHING SCALE AND SUMMARY	
D    BASE FLEET AND CENTER OF GRAVITY DIAGRAMS	
E    FUNCTIONAL DECOMPOSITION OF DEVICE REQUIREMENTS	
F    ADVISORY COMMITTEE	



## **APPLICATION OF THE QUALITY FUNCTIONAL DEPLOYMENT METHOD IN MOBILITY AID SECUREMENT SYSTEM DESIGN**

### **ACKNOWLEDGEMENTS**

The Independent Locking Securement (ILS) System Project was made possible by the sponsorship and support of the US Department of Transportation, Federal Transit Administration, University Research and Training Program, and National Easter Seal's Project ACTION. In particular, the ILS System Project team thanks Mr. George Izumi, and Ms. Marina Drancsak of the U.S. Department of Transportation, Federal Transit Administration, University Research and Training Program, for their encouragement, direction, guidance and support. The project team thanks Mr. David Capozzi and Mr. Jim Flemming of the National Easter Seal's Project ACTION, for their support, direction and guidance.

The ILS System Project would not have been successful without the strong support of the Advisory Committee. The Advisory Committee was made up persons with disabilities who regularly ride public transportation as well as representatives of a number of transit agencies in the Pacific Northwest, and state and local government officials. Appendix E lists the members and addresses of the advisory committee. The project team consisting of David Ullman, Joseph Zaworski, Derald Herling, Garrett Clark, Wahib Thabet and K.M. Hunter-Zaworski, would like to thank a number of people who gave special support to the project.

The project team is thankful for the support for the project given by Drs. Reistad and Huber, Chairmen of the Department of Mechanical Engineering and Civil Engineering, respectively at Oregon State University. We also thank Dean Owen and Associate Dean Schroeder, of the College of Engineering for their patience and support of the project. The project team also thanks Joel Dille and Don Freeman, mechanical engineering undergraduate students, for their dedication and enthusiasm in helping to refine the first interfaces for manual wheelchairs.

The project team is very grateful for the strong support, mentoring, guidance and direction given by Mr. Bill Henderson, of Snohomish Senior Services.

The project team would like to give a very special acknowledgement to Patricia Nielsen, Accessible Transit Planner with TRI-MET in Portland, Oregon, and the members of her Citizens Advisory Committee for Accessible Transit. We also thank Jan Campbell of the city of Portland for assistance in organizing advisory committee meetings. Their support and guidance were instrumental in the direction of the project.

The project team would also like to give a very special thank you to Micki Kaplan, Transit Planner, Frank Whisenhunt and Ron Berkshire, maintenance supervisors at Lane Transit District (LTD) in Eugene. Their support was invaluable for the human factors testing. We thank George Brown of the maintenance department for driving the bus while we were testing the prototype. We have a very special thank you to Dave Kleger of the LTD Citizens Advisory Committee for his willingness to be one of the first test subject in the on-road tests of the securement system.

The project team also thanks Dr. Larry Schneider and his staff of the University of Michigan Transportation Research Institute for their assistance in the sled tests of the prototypes.

The project team thanks the following persons who volunteered to help with the human factors testing. Cindy Jenkins, OSU Business Office, Wayne Lowell, OSU Controllers Office, Marshall Smith, OSU Student, and Mark Mitchell, OSU Student.

We would also like to thank Bob McCowan and Dave Norstrom from Battelle for their contribution to the project, as well as Bruce Chown, and Al Little from B.C. Transit.

## **CHAPTER 1 - INTRODUCTION**

### **Introduction**

The Independent Locking Securement System Project (ILS System Project) is a successful attempt to respond to the transportation community's need for a "universal" securement/restraint system that will accommodate most wheeled mobility aids, including three-wheeled scooters, in common use on public transportation systems. The research project was designed to assist transit agencies as well as manufacturers in providing access on public transit vehicles to persons with disabilities and to meet the requirements of the Americans with Disabilities Act (ADA). The project focused on mobility aid securement problem analysis, design and construction of several securement system prototypes, and extensive testing of both the operational and engineering aspects of the securement system.

The primary objective of the ILS System Project was to design, build and test a wheeled mobility aid securement system that would operate with all mobility aids in "common use" on fixed route transit vehicles. The major requirements for the system were to: maximize mobility aid user independence, minimize transit vehicle operator involvement, minimize securement and release time, and satisfy all the proposed securement standards and guidelines.

### **Report Organization**

The ILS System Project has been documented in two reports. Volume 1 report details the application of the Quality Functional Deployment Method in developing design specifications. Volume 1 also includes a synthesis of the state of the art prior to the development of the Securement System. Volume 1 provides an excellent guide on the application of the QFD, and also details the technical specifications for a securement system. Volume 2 describes the design that was developed by the project, and in addition it also documents the extensive engineering testing program that was undertaken as part of the project. The report also documents additional engineering research that was done on the reaction of mobility aids to side loads.

### **Organization of the Volume 1 Report**

This volume of the final report details one part of an effort to design an easy-to-use, effective securement system for mobility aids (wheelchairs, scooters, power bases, etc.) on transit vehicles. Specifically, Volume 1 focuses on the Quality Functional Deployment (QFD) technique used to understand this problem which has proved challenging both technically and politically. The technical difficulty of securing mobility aids in both fixed route transit vehicles (buses) and demand response vehicles (generally vans) is evidenced by the dissatisfaction of the user communities with what is currently available. Political difficulty is evidenced by the number of diverse committees that are concerned with the problem and the

number of standards that organizations are producing requirements for such systems. The complexities will become clear in this report.

Chapter 1 of this report discusses the background of the project, problem statement, research goals, design objectives, and introduces the Project Advisory Committee. Chapter 2 introduces the Quality Functional Deployment Method with minor reference to how it was applied to the Independent Locking Securement System Project. Chapter 3 provides a brief literature review and summarizes a survey of present technology. Chapters 4 and 5 discuss details of the QFD application to the securement system problem. Chapter 4 details the engineering requirements of a securement system for mobility aids. Chapter 5 discusses the benchmarking of existing securement technology. Chapter 6 offers conclusions and recommendations that pertain to the application of the QFD method. Finally, Chapter 7 provides a list of references that are used in this report. Appendix A includes an annotated bibliography that was used for the project. Appendix B includes a Summary of the Current Securement System Technology, Appendix C includes the Customer questionnaire, Appendix D is the Center of Gravity and Base Fleet of Mobility Aids, Appendix E is the Functional Decomposition of the Device Requirements, and Appendix F is a listing of the members of the Advisory Committee.

## **Background**

Providing access on public transit vehicles for persons with disabilities is a well established goal of all public transit agencies. People with disabilities use a variety of mobility aids and other assistive devices and rely on public transportation for their personal mobility. However, the diversity and styles of wheeled mobility aids create significant problems for public transit agencies when it comes to securing them on transit vehicles. This problem was identified by Project ACTION's reconnaissance survey as well as by a large number of transit agencies. The need for a universal securement system design was also identified as a national research priority. Before going further into the problem, it is important to have a well defined vocabulary. Some of the key words and phrases used in this report are as follows.

## **Vocabulary**

**A Person with a Disability:** A person with a disability is defined in part by the U.S. Department of Transportation as, "any individual who, by reason of illness, injury, age, congenital malfunction, or other permanent or temporary incapacity or disability is unable, without special facilities, or special planning or design, to utilize mass transportation facilities and services as effectively as persons who are not so affected."

**Mobility Aid:** Mobility aid refers to a chair mounted on wheels to facilitate the mobility of persons with disabilities in a seated position. Some common wheeled mobility aids are: three wheeled scooters, power base wheelchair, powered wheelchairs, light weight sport style wheelchairs, and manual wheelchairs.

**Capture System:** The capture system refers to the apparatus installed on transit vehicles for the purpose of limiting motion of an occupied wheeled mobility aid in a specific location in the vehicle.

**Interface Unit:** This refers to the apparatus attached to the back of the mobility aid that provides attachment points for the capture system.

**Securement System:** The securement system refers to both the capture mechanism and interface unit functioning as one unit.

**Restraint System:** The purpose of the restraint system is to hold a passenger in a seated position during transportation by transit vehicles. (Note the distinction: a securement system is for a mobility aid and a restraint system is for a person.)

### **Problem Statement**

The problem of securing mobility aids stems from two sources. First is the need to adequately secure the mobility aids in transit vehicles. Currently a number of different types of systems are available to accomplish this, most making use of three or four belts that hook from the mobility aid to the floor of the vehicle. These systems were derived from hardware developed for the securement of cargo on aircraft. They require the driver or attendant to hook each end of each belt and tighten each to ensure that the mobility aid will not shift during normal operations and not break loose during accident conditions. Difficulties with these systems arise in securing scooter and powerbase type mobility aids as there are no acceptable places to attach the belts.

The second source for the problem of securing mobility aids is the American with Disabilities Act (ADA) requirement that all fixed route transit vehicles be accessible. The ADA definition of accessibility requires that mobility aids "in common use" must be able to both get on to the vehicle and be secured once on board. Current efforts at securing mobility aids on fixed route vehicles are either a derivation of the belt systems, use wheel clamps, or a combination of belts and clamps. This report will describe implicitly some of the problems with the existing securement systems.

### **Research Goals**

The project undertaken at Oregon State University had two primary goals: to fully understand the problem and to design, build and test a prototype system based on this understanding. These two requirements needed an organized and unbiased party to develop the information needed to design new systems and develop new ideas. Additionally, an organized method, such as the Quality Functional Deployment Method (QFD) allows others to critique it, build on it and modify it as the problem matures and evolves in time. In meeting these requirements, the researchers involved in this project had no ties to any of the manufacturers, users, government organizations or standards committees and thus were unbiased in their efforts. Additionally, the (QFD) method described in this report is organized, repeatable and modifiable by other researchers. Finally, and most importantly, the method resulted in the generation and

organization of information that formed the foundation for development of concepts and a prototype securement system.

A number of transit agencies have devised and used various securement systems as they attempted to provide service to people with disabilities. In the absence of federal design requirements, it is not surprising that these design efforts by people in various locations did not produce a universally accepted system. As more and more people with disabilities ride public transit, and as the types and styles of mobility aids they use continue to proliferate, individual public transit agencies are now faced with the problem that is beyond their ability to solve. Securement systems that were adequate in the past are no longer suitable for the newer mobility aids. The needs of passengers and transit agencies, and the new ADA standards for securement of mobility aid passengers, mandated a fresh look at the problem. It became clear that a universal system had to be designed that would meet the requirements of all customers.

### **Design Objectives**

The major design objectives of the Independent Locking Securement System were as follows:

1. Accommodate a large variety of mobility devices, such as sports style manual wheelchairs and "scooter" style electric wheelchairs,
2. Safely secure the mobility devices and provide restraint for the passenger,
3. Satisfy the USDOT/FTA American with Disabilities Act (ADA) regulations and guidelines, as well as the proposed Canadian Standards Association (CSA) regulations for Mobility Aids Securement and Occupant Restraint (MASOR),
4. Reduce securement time and operator involvement, and provide as much independent operation by wheeled mobility aid occupant as possible,
5. Reduce time for release of mobility device from the securement system, to reduce cycle time, and permit rapid evacuation if necessary,
6. Be applicable to both fixed route and demand responsive transit vehicles, and satisfy the technical requirements of the different vehicles operating in urban, suburban and rural settings,
7. Operate in all climatic conditions,
8. Prevent relative movement between the mobility aid and the vehicle in regular and emergency operation,
9. Maximize occupant protection,
10. Not require extensive operator training for correct use,
11. Operate as a continuum between the transportation vehicle-mobility aid and occupant.

### **Project Advisory Committee**

An advisory committee was formed to assist with the project. An Advisory Committee had been formed in 1987 for the Human Factors in Public Transportation Safety Project undertaken by OSU/TRI for



the USDOT/FTA. Both the new and previous advisory committees had many of the same members. The project advisory committee was made up of persons with disabilities who regularly use transit, and who represent organizations associated with disabilities. Other members of the advisory committee included: accessible transit planners, transit vehicle operators, maintenance personnel, transit managers, and state government representatives. The advisory committee had representatives from Lane Transit District (LTD) in Eugene, Oregon, TRI-MET in Portland, Oregon, METRO in Seattle, Washington, and B.C. Transit in Vancouver, B.C. Appendix F includes a list of members of the Advisory Committee. A number of other people provided direction for the project but were unable to attend the Advisory Committee Meetings and this includes: Bill Henderson, Snohomish Senior Services, Sue Stewart and Catherine Rice, Seattle METRO, Park Woodworth, TRI-MET, Micki Kaplan, LTD, Al Little, B.C. Transit, and David Capozzi, NESS Project ACTION.



## **CHAPTER 2 - THE QUALITY FUNCTION DEPLOYMENT METHOD FOR UNDERSTANDING ILL-DEFINED PROBLEMS**

### **Quality Function Deployment (QFD)**

The QFD method was developed in Japan in the mid-1970s and introduced in the United States in the late 1980s. Using this method, Toyota was able to reduce the costs of bringing a new car model to market by over 60 percent and to decrease the time required for its development by one-third. They achieved results while improving the quality of the product. Many U.S. companies now use the QFD method regularly. As described below, the method involves a time commitment, but it assumes the problem is understood and saves much time later. Its effectiveness thus dictates that it be followed from the beginning of all design projects. For more details on this method see references 1 or 2.

The six steps of the QFD method are presented below and illustrated in the form shown in Fig. 1.

#### **Step 1: Identifying the Customer(s)**

The goal in understanding the design problem is to translate the customer requirements into a technical description of what needs to be designed. Or, as the Japanese say, "Listen to the voice of the customer." To do this, we must first determine exactly who is the customer. The customers for the securement project include: the mobility aid passenger, the vehicle operator, the transit system maintenance personnel, transit system managers, transit vehicle manufacturers, mobility aid manufacturers, other passengers, standards groups/other organizations, and mobility aid and securement system manufacturers. An advisory committee was formed to advise on all aspects of the project. All the customer types were represented on the advisory committee.

#### **Step 2: Determining Customer Requirements**

Once the customers have been identified, the next goal of the QFD method is to determine what the customer wants in the product. The goal here is to develop a list of all the requirements that will affect the design. As it is important that all the customer requirements be taken into account, this procedure should be accomplished with the whole design team and should be based on the results of customer requirement surveys.

A list of customer requirements should be made in the customer's own words such as "easy," "fast," "natural," and other abstract terms. A later step in the process will be to translate these terms into engineering parameters. Developing this information is an iterative effort, the goal being to develop a complete list. One way to ensure this is to organize the list by types of requirements. The major types are shown in Table 1.

<p style="text-align: center;">ENGINEERING REQUIREMENTS</p>		<p style="text-align: center;">CUSTOMER REQUIREMENTS</p>		<p><b>USER CODES:</b></p> <p>MAP MOBILITY AD PASSENGER          TO TRANSIT SYSTEM—OPERATOR          TM TRANSIT SYSTEM—MAINTENANCE          TE TRANSIT SYSTEM—PASSENGER          VM TRANSIT VEHICLE MANUFACTURE          MAM MOBILITY AD MANUFACTURE          OP OTHER PASSENGERS          SG STANDARD GROUP/OTHER ORGANIZATION          TV TRANSIT VEHICLE          SSM REQUIREMENT SYSTEM MANUFACTURE</p>		<p>USER CODES</p>		<p>CUSTOMER WEIGHTING</p>		<p>1. PERCENT OF USERS THAT CAN REMAIN IN MOBILITY AD</p>		<p>2. MOBILITY AD PASSENGER TRAINING TIME REQUIRED</p>		<p>3. AVERAGE NUMBER OF WAYS TO CONNECT EACH MOBILITY AD IN BASE FLEET</p>		<p>4. TRANSIT OPERATOR TRAINING TIME NEEDED</p>		<p>5. ENGAGING-NUMBER OF THIS TRANSIT OPERATOR NEEDS TO LEAN OVER MOBILITY AD PASSENGER</p>		<p>A—WHEEL CLAMP ONLY</p>		<p>B—BELT SYSTEM ONLY</p>		<p>C—WHEEL CLAMP AND BELT</p>		<p>D—MOBILITY AD WITH CENTER PIN</p>		<p>E—WHEEL SECUREMENT BRACKET SYSTEM</p>	
				<p>1.0 PERFORMANCE REQUIREMENTS</p>		<p>1.1 EASY TO USE SECUREMENT SYSTEM</p>		<p>NO MOBILITY AD PASSENGER CAN REMAIN IN MOBILITY AD</p>		<p>MAP, SSH</p>		<p>0</p>		<p>5</p>		<p>5</p>		<p>5</p>		<p>5</p>		<p>5</p>		<p>5</p>					
				<p>NO MOBILITY AD PASSENGER WILL NEED SPECIAL TRAINING</p>		<p>MAP, TE, MAM</p>		<p>9</p>		<p>4</p>		<p>4</p>		<p>4</p>		<p>4</p>		<p>4</p>		<p>4</p>									
				<p>NO SECUREMENT SYSTEMS CAN BE USED IN ONLY ONE OR MORE WAYS</p>		<p>MAP, TO, TE, MAM, SSH</p>		<p>9</p>		<p>5</p>		<p>2</p>		<p>4</p>		<p>5</p>		<p>5</p>		<p>5</p>									
				<p>NO TRANSIT OPERATOR WILL NEED SPECIAL TRAINING</p>		<p>TO, TE, MAM, SSH</p>		<p>9</p>		<p>5</p>		<p>2</p>		<p>4</p>		<p>5</p>		<p>3</p>		<p>5</p>									
				<p>NO PASSENGER IS PERSONAL SPACE IS NOT PROVIDED FOR THE PASSENGER</p>		<p>MAP, TO, TE</p>		<p>9</p>		<p>5</p>		<p>1</p>		<p>3</p>		<p>5</p>		<p>2</p>		<p>2</p>									
				<p>UNITS TARGET</p>				<p>X PIN = PIN =</p>																					
				<p>100 0 1 20 0</p>																									
<p><b>RELATION CODES:</b></p> <p>9—STRONG RELATION          3—MEDIUM RELATION          1—WEAK RELATION          BLANK—NO RELATION</p>		<p><b>BENCHMARK CODES:</b></p> <p>1. DOES NOT MEET REQUIREMENT          2. MEETS REQUIREMENT SLIGHTLY          3. MEETS REQUIREMENT SOMEWHAT          4. MEETS REQUIREMENT MOSTLY          5. MEETS REQUIREMENT COMPLETELY</p>		<p><b>BENCHMARKS</b></p> <p>A—WC          B—4 BELT          C—WC&amp;B          D—PIN          E—</p>																									

FIGURE 1. PROBLEM UNDERSTANDING FORM

TABLE 1. TYPES OF CUSTOMER REQUIREMENTS

Performance Functional performance Spatial constraints
Appearance
Time
Cost Capital Unit
Manufacture/Assembly Quantity to be manufactured Company capabilities
Standards
Safety
Environmental Issues

Performance requirements can be roughly divided into those concerning the design's function and the spatial constraints on it. Functional performance requirements are those elements of the performance that describe the product's behavior; its human interface; its environmental operating conditions; its aging properties; and its failure and repair possibilities. Spatial constraints, on the other hand, are the performance requirements that relate to how the product must physically fit with other existing objects. Two meetings were held with the advisory committee to develop customer requirements.

### Step 3: Customer Weightings, Establishing the Importance of the Requirements

The next step is to evaluate the importance of each of the customer requirements. This is accomplished by generating a weighing factor for each requirement and entering it in Figure 1. The weighting will give an idea of how much effort, time and money to invest in achieving each requirement.

Two questions that need to be addressed here: (1) To whom is the requirement important? And (2) How is a measure of importance developed for this diverse group of requirements? Since a design is "good" only if the customer thinks it is good, the obvious answer to the first question is, "The Customer." However, we know that there may be more than one customer. In the case of the securement system, the desires of the mobility aid passengers and those of the transit vehicle operator may not be the same. This type of discrepancy must be resolved at the beginning of the design process. Sometimes a designer's hardest job is to determine whom to please. An advisory committee workshop was held that involved all the customers to determine the customer weightings. A questionnaire for weightings only, based on the functional requirements was developed and used at the advisory committee workshop. The customers were

asked to weight each of the functional requirements. The questionnaires were also sent to other customers who were not at the advisory committee workshop. All the questionnaires were analyzed, tabulated and used to develop the matrix. The questionnaire is shown in Appendix C. The weightings and summary statistics of the questionnaire are shown at the end of the questionnaire and are broken down according to customer group.

#### **Step 4: Benchmark the Competition**

The goal of competition benchmarking is to determine how the design engineer perceives the competition meets each of the customer requirements. The purpose for doing this is two fold; first, it helps the design team evaluate similar products that already meet some of the customer requirements, and, second, it points out opportunities to improve on these products. In some companies this process is called benchmarking and is a major aspect of understanding a design problem. In benchmarking, each competing product must be compared with customer requirements. Some of these comparisons are objective and can be measured directly; others are subjective and customer opinion may be needed. For each customer requirement, we rated the existing designs on a scale of 1 to 5, where

- 1 = the design does not meet the requirement at all
- 2 = the design meets the requirement slightly
- 3 = the design meets the requirement somewhat
- 4 = the design meets the requirement mostly
- 5 = the design fulfills the requirement completely

Though these are not very refined ratings, they do give an indication of how the competition is perceived by the customer. We will look at the competition again in Step 6 of the QFD technique.

#### **Step 5: Translating the Customers' Requirements into Measurable Engineering Requirements**

The goal here is to develop a set of engineering requirements (often called design specifications) that are measurable for use in evaluating proposed product designs. First, we need to transform the **customer requirements** to **engineering requirements**. Second, we need to make sure that each engineering requirement is **measurable**. Some customer requirements are directly measurable and do not require translating. But requirements like "easy to attach," needs to be refined so it can be measured. It is toward these more abstract requirements that the following is directed.

We begin by finding as many engineering measurements as possible that can indicate a level of achievement for each customer requirement. For example, the "easy to attach" customer requirement can be measured by (1) the number of steps to attach, (2) the time to attach, (3) the number of parts needed, and (4) the number of standard tools needed. Each of these is clearly measurable except the time to attach, which will be dependent on the skill and training of the customer.

An important point here is that every effort needs to be made to find as many ways as possible to measure each customer requirement. If there are no measurable engineering requirements for a specific customer requirement, then the design engineer will not be able to know if he has met the requirement. If no measurement can be found, it is usually an indication that the customer requirement is not well understood. Possible solutions for this are to break the requirement into finer independent parts or to redo step 3, with specific attention to that specific requirement.

To complete this step, we fill in the center portion of the Problem Understanding Form (Figure 1). Each cell of the form represents how an engineering requirement relates to a customer requirement. The strength of this relationship can vary, with some engineering requirements providing strong measures for a customer requirement and others providing no measure at all. This relation will be conveyed through numerical values. We will use four:

- 9 = strong relation
- 3 = medium relation
- 1 = weak relation
- Blank = no relation at all

#### **Step 6: Setting Engineering Targets for the Design**

The last step in the QFD technique is to determine target values for each engineering measure. As the product evolves, these target values will be used to evaluate the product's ability to satisfy customer requirements. There are really two actions needed here. The first is to ascertain how the competition, examined in step 4, meets the engineering requirements, and the second is to establish the value to be obtained with the new product.

In step 4, competition products were compared to the customers requirements. In step 6, they need to be measured relative to the engineering requirements. This assumes that the knowledge and equipment exists for evaluation. Also, the values obtained by measuring the competition give a basis for establishing the targets. This usually means obtaining actual samples of the competition's product and making measurements on them in the same way that measurements will be made on the product being designed.

Setting targets early in the design process is important; targets set near the end of the process are easy to meet but have no meaning. Some customer requirements will have ready-made targets — the requirement that a device must lift 100 Kilograms mass, for instance, is measurable and provides a specific target. But for other requirements, realistic targets need to be set. These values define an ideal product and must be based on what is physically realizable, which is why it is essential to examine the competing products.

The best targets are set for a specific value. Less precise, but still usable, are those set to within some range. A third type of target is a value made to be as large or as small as possible. Although measurable, these extremes are not good targets, as they give no information that tells when the

performance of the new product is acceptable. However, evaluation of the competition should give at least a some range for the target value.

### **The QFD Technique: Independent Locking Securement System Application**

The QFD technique serves to insure that the problem is well understood. It is useful on all types of design problems and results in a clear set of customer requirements and associated engineering measures and targets. It may appear to slow the design process but, in actuality, it doesn't. Time spent developing information in the Problem Understanding Form is returned in time saved later in the design process.

In steps 2 and 3 of the QFD technique, we had the assistance of an advisory committee. The makeup of this committee was based on our identification of the "customer" for the securement system product. The list of customer types evolved as literature was studied and the methodology followed. The types of customers identified were:

- Mobility Aid Passenger
- Other Passengers
- Transit System Operator (driver)
- Transit System Maintenance Personnel
- Transit System Manager
- Transit Vehicle Manufacturer
- Mobility Aid Manufacturer
- Securement System Manufacturer
- Standards Groups/Other Organizations

The advisory committee, consisting of representatives from most of these groups, met to assist in developing the customers requirements and weighing their importance. The list of customer requirements that evolved through these meetings and review of the literature are listed in Figures 2-4. These figures are actually parts of the resulting QFD matrix which is too large to publish. Thus it has been broken into three sub matrices. The customers requirements that were developed in this project are the sum of the left most column in the three figures.

It is not possible to discuss all the considerations that went into the QFD matrix. However, the basic factors in the matrix followed directly from the project proposal and earlier work undertaken by Hunter-Zaworski [8,9]. One of the most useful aspects of the QFD method is the effort required to translate the customer requirements into engineering requirements. The need to convert the usually abstract customer requirements into measurable variables requires extensive effort to understand the basic elements of the problem and their interactions. Thus, in Chapter Four, each engineering requirement that comes from the customer requirements in Figures 2, 3, and 4 will be discussed in detail. First in Chapter 3, the literature reviewed for background is discussed.



1.0 PERFORMANCE REQUIREMENTS	1.1 EASY TO USE SECUREMENT SYSTEM	1.1.1 MOBILITY AID PASSENGER CAN REMAIN IN MOBILITY AID		
		1.1.2 MOBILITY AID PASSENGER WILL NEED MINIMAL TRAINING		
		1.1.3 SECUREMENT SYSTEM CAN BE USED IN ONLY ONE OBVIOUS WAY		
		1.1.4 TRANSIT OPERATOR WILL NEED MINIMAL TRAINING		
		1.1.5 PASSENGER'S PERSONAL SPACE IS NOT INVADED DURING SECUREMENT		
		1.1.6 SECUREMENT SYSTEM WILL ALLOW	1.1.6.1 EASY POSITIONING OF MOBILITY AID	
			1.1.6.2 EASY CONNECTION OF MOBILITY AID	
			1.1.6.3 EASY UTILIZATION OF PERSONAL RESTRAINT	
			1.1.6.4 EASY DISCONNECTION OF MOBILITY AID	
			1.1.6.5 ADJUSTABILITY FOR ANY COMMONLY USED MOBILITY AID	
	1.1.7 SECUREMENT SYSTEM SHALL BE	1.1.7.1 EASY AND HEAT TO STOW		
		1.1.7.2 EASY AND HEAT TO RETRIEVE		
	1.1.8 CONNECTION TO SECUREMENT SYSTEM SHALL REQUIRE MINIMAL USE OF TOOLS			
	1.2 SECUREMENT SYSTEM OPERATION	1.2.1 SECUREMENT SYSTEM SHALL BE	1.2.1.1 ACTIVATED OR CONVENIENTLY ENHANCED AND RELEASED BY MOBILITY AID PASSENGER	
		1.2.2 WILL HAVE FAST SECUREMENT	1.2.2.1 INTO DEVICE	
			1.2.2.2 OUT OF DEVICE	
		1.2.3 WILL PROVIDE OPTIONAL PASSENGER RESTRAINT		
		1.2.4 WILL OPERATE AS DESIGNED ON WET, COLD, SALTY, OR SNOWY CONDITIONS		
	1.2.5 TRANSIT SYSTEM OPERATOR INTERACTION WITH PASSENGER SHALL BE MINIMAL			
	1.3 MOBILITY AID REQUIREMENTS FOR SECUREMENT SYSTEM	1.3.1 NO MODIFICATION OF THE MOBILITY AID WILL BE REQUIRED		

FIGURE 2. ONE THIRD QFD MATRIX CUSTOMER REQUIREMENTS

1.0 PERFORMANCE REQUIREMENTS (CONT'D)	1.4 SECUREMENT SYSTEM ENERGY CONTROL	1.4.1 WILL RESTRAIN MOBILITY AID WITHOUT DAMAGE DURING:	1.4.1.1 NORMAL ACCELERATION
			1.4.1.2 NORMAL DECELERATION
			1.4.1.3 NORMAL CORNERING
		1.4.2 WILL RESTRAIN MOBILITY AID WITHOUT DAMAGE DURING:	1.4.2.1 ACCIDENT ACCELERATION FOREWARD
			1.4.2.2 ACCIDENT ACCELERATION REARWARD
			1.4.2.3 ACCIDENT ACCELERATION SIDWAYS
		1.4.3 WILL CONTROL ENERGY TRANSFER TO MOBILITY AID	
		1.4.4 WILL RESTRAIN MOVEMENT OF MOBILITY AID DURING NORMAL STARTS AND STOPS	1.4.4.1 FOREWARD
			1.4.4.2 REARWARD
		1.4.5 WILL RESTRAIN MOVEMENT OF MOBILITY AID WHILE CORNERING	
	1.4.6 HARDWARE SHALL BE POSITIVE LATCH TYPE		
	1.4.7 MOBILITY AID WHEELS WILL NOT SLIP ON WET FLOOR OF MOBILITY AID STATION		
	1.5 SECUREMENT SYSTEM DAMAGE POTENTIAL	1.5.1 MATERIALS WILL NOT STAIN SOLE, OR TEAR ANY PASSENGER'S CLOTHING OR HANDS	
		1.5.2 SYSTEM SHALL NOT BE ABLE TO BE OVERTIGHTENED	
		1.5.3 SECUREMENT SYSTEM SHALL BE:	1.5.3.1 FREE OF SHARP EDGES
1.5.3.2 NON-CORROSIVE			
1.5.4 SYSTEM WILL NOT BE CAPABLE OF CAUSING HARM TO OTHER PASSENGERS			
1.5.5 WHEN NOT BEING USED, SHALL BE REASONABLY PROTECTED FROM VANDALISM			

FIGURE 3. ONE THIRD QFD MATRIX CUSTOMER REQUIREMENTS

2.0 SPATIAL REQUIREMENTS	2.1 WHILE IN USE	2.11 MOBILITY AID SHALL BE FORWARD FACING	
		2.12 MOBILITY AID STATION SHALL HAVE A LIMITED VOLUME	
		2.13 SECUREMENT SYSTEM WILL NOT INTERFERE WITH OTHER PASSENGERS	
	2.2 WHILE STOWED	2.21 SECUREMENT SYSTEM WILL NOT INTERFERE WITH OTHER PASSENGERS	
3.0 COST REQUIREMENTS	3.1 EQUIPMENT COST	3.11 COST PER STATION WILL BE REASONABLE	
		3.12 COST PER MOBILITY AID WILL BE REASONABLE	
4.0 APPEARANCE	4.1 STURDINESS	4.11 SECUREMENT SYSTEM USEFUL LIFE WILL EQUAL VEHICLE USEFUL LIFE	
		4.12 WILL APPEAR STURDY	
5.0 SAFETY REQUIREMENTS	5.1 SECUREMENT	5.11 RED COLORS WILL IDENTIFY EMERGENCY RELEASE MECHANISMS	
		5.12 WILL NOT BECOME INOPERABLE IF MOBILITY AID TIRCS ARE DEFLATED	
6.0 MAINTENANCE REQUIREMENTS	6.1 TIME	6.11 WILL REQUIRE MINIMAL MAINTENANCE TIME	
	6.2 RETROFIT	6.21 CAN BE RETROFITTED TO VEHICLES	
	6.3 FEATURES	6.31 WILL BE EASY TO KEEP CLEAN	

FIGURE 4. ONE THIRD QFD MATRIX CUSTOMER REQUIREMENTS



## CHAPTER 3 - LITERATURE SEARCH

### Literature Search

An extensive literature search was conducted for commercial securement systems, vendor material for mobility aids, past tests of securement systems, relevant conference materials, and design reports. (See Appendix A for details.) The goal of the literature search was to understand the design problem, define all potential customers, understand what customers wanted in a securement system, understand the scope of application of the securement system, become familiar with the many types of mobility aids and securement systems, and study previous testing of securement devices.

### Present Technology Survey

The survey of present technology was undertaken by surveying transit agencies [21], collecting technical information on commercial and prototype securement systems. This information is organized in Appendix B. Three general categories cover the present technology for securement systems: devices that have been designed and built and are commercially marketed by vendors; devices that are put together by local transit agencies from component parts commercially available; and devices that are the result of specific projects, or ideas that have been generated but have not gone past the prototype stage. The Transit agency survey [21] identified two types of securement system component devices presently in use. The first is the basic seat belt, modified for use in a number of configurations as the primary securement device. The second is the commercial wheelchair wheel-clamp device. Some transit agencies combined these two devices to create a securement system. All of these systems are manually operated.

Securement Systems that are commercially available are three basic types:

- A seat belt system — Many companies market these systems; most use four seat belts attached to the wheel chair in various ways, such as by loops or with hooks. Seat belt systems have only been applied to manual or electric powered wheel chairs. These systems are manual in operation.
- A wheel clamp system — Many companies market a system that uses a wheel clamp device. Some are single wheel clamps; some feature double wheel clamps. The use of a wheel clamp system is restricted to common wheel chairs only. Mobility aid passengers back their wheel chairs into the clamp which then latches closed. There is generally a manual latch release handle.
- Other systems — A few companies market a bolt on pin/bar latching device. The pin or bar is mounted on the mobility aid and a capture mechanism is mounted on the vehicle. These systems are power activated and released. This type of system is found exclusively in the personal van vehicle market. A search of the US Patent Office Gazette yielded a number of patents that were of interest. These devices were of the same types of the above. Table 2 lists the most recent securement/restraint system patents.

TABLE 2. RECENT SECUREMENT/RESTRAINT PATENTS

Issue Year	Patent Number	Title
1977	4019752 4060271	Wheelchair Restraint Device Wheelchair Hold Down Assembly
1978	4103934	Folding Seat and Wheelchair Restraint
1981	4265478	Safety Locking Mechanism for Wheelchairs
1982	4325576	Adjustable Wheelchair Holding Device
1984	4427210 4449561 4455046 4457551	Wheelchair and Occupant Restraint System Non-Skid Device for Wheelchairs and the Like Safety Device for the Vehicular Transport of a Person Travelling in a Wheelchair Vehicle Speed-Lock Wheelchair Restraint System
1985	4492403 4511171 4538825	Method and Apparatus for Securing a Wheelchair to a Vehicle Floor Wheelchair Restraint Wheelchair Anti-Rollback Mechanism
1987	4688843 4690364	Wheelchair Restraint System for Vehicle Wheelchair Restraining Device
1988	4729573 4730964 4754946	Wheelchair Latching Device Wheelchair Restraint System Wheelchair Restraining Device
1990	4913265 4966392 4973022	Vehicle Immobilizing Device Wheelchair and Occupant Restraints Wheelchair Securement Apparatus

## **CHAPTER 4 - THE ENGINEERING REQUIREMENTS FOR A SECUREMENT SYSTEM**

In this chapter the engineering requirements for the mobility aid securement system will be discussed. These are based on the customer requirements and can be considered as a translation of these into information that is directly usable in the evaluation of proposed products. Specifically, the engineering requirements must meet three criteria:

- Each engineering requirement must be measurable. This means that each must have specific units (e.g. meters, number of objects, number of steps, or kg).
- Each engineering requirement must have a specific target. This will be based on the benchmarks of competition and the desires of the design team.
- Each customer requirement must have at least one engineering requirement.

The engineering requirements were developed by considering each customer requirement and asking the question, "How many ways can be found to measure this requirement." The resulting list contains 72 engineering requirements that measure the 52 customer requirements and fully characterize the securement problem. These requirements are shown across the top of Figures 2,3 and 4 and are discussed one at a time throughout the remainder of this section.

### **1. Percent of Mobility Aid Passengers Who can Remain in Mobility Aids**

This requirement was in response to the policy of some transit agencies that required scooter passengers to secure their aids and then sit in a regular, fixed seat. However, the American with Disabilities Act (ADA) regulations do not permit this type of discrimination, and thus a target for this requirement is that 100% of all mobility aid passengers should remain seated in their mobility aids.

### **2. Mobility Aid Passenger Training Time Required**

Some transit agencies provide training for mobility aid passengers. For example, Lane Transit District in Eugene, Oregon, will send a vehicle to the mobility aid passenger's home so that use of the lift, negotiation of the aisle and use of the securement system can be practiced. In the ideal situation, no training is needed to use the securement system. Thus, the target is zero minutes for training.

### **3. Average Number of Ways to Connect Each Mobility Aid in a Base Fleet**

It has been noted that some securement systems can be fastened to the mobility aid in a variety of ways (e.g. many belt systems). Since these systems were designed to be used in only one way and tested only in that configuration, any other use is potentially unsafe. Thus, an ideal system should be usable in only one manner to ensure that it can meet the designer's intent.

In order to measure this and other requirements it is necessary to define a base suite of mobility aids. During design, this fleet will serve as a test sample to see how well this requirement is met. The base fleet is

1. Standard Manual Wheelchair
2. Light Weight Manual or Sport Chair
3. Standard Electric Wheelchair
4. Power Base Unit
5. Three Wheeled Scooter.

With the numerous mobility aids on the market it was apparent that the project had to restrict the design space of mobility aids to a base fleet that represented all common types. In Appendix D the five generic classes that make up the base fleet of mobility aids are discussed and illustrations of each mobility aid, center of gravity measurements and the mass of each mobility aid are also presented in the appendix. The following types and models of mobility aids were chosen as representative:

Unit A - A Manually propelled/Self propelled/Conventional wheelchair

Model: INVACARE Rolls 1000 Series Wheelchair

Unit B - A Manually propelled/Self propelled/Ultralite wheelchair

Model: CHAMPION 3000ST wheelchair

Unit C - A Battery powered/Conventional wheelchair/Indoor-outdoor/Fixed frame

Model: INVACARE Power Rolls ARROW 4M900 Series

Unit D - A Battery powered/Powered base/Outdoor

Model: FORTRESS SCIENTIFIC Model 655FS Power Chair

Unit E - A Battery powered/3 Wheeled Scooter/Rear wheel drive

Model: FORTRESS Model 2000FS but later a MOBIE II was used for field and sled testing due to its availability.

The target for this requirement is that each member of the base fleet can be secured in only one way.

#### **4. Time Needed for Transit Operator Training**

Transit operator training time is measured in the minutes per year operators are given instruction in how to use the securement system. Since additional training is a burden to the transit company, the goal for this requirement is based on in-service training time available, commonly 20 minutes. Thus 20 minutes per year was taken as the target for this requirement.



**5. & 6. Transit Operator's Need to Lean Over the Mobility Aid Passenger when Engaging or Releasing the Securement System**

**7. & 8. Transit Operator's Need to Touch Mobility Aid Passenger**

**9. & 10. Transit Operator's Need to Work Around Legs of Mobility Aid Passenger during Securement or Release**

**11. & 12. Transit Operator's Need to Work Behind the Mobility Aid Passenger**

One of the customer requirements was that the mobility aid passengers personal space should not be invaded. This requirement spawned eight engineering requirements. The eight are each measured by the number of times the transit operator needs to do a specific activity that could make either the operator or mobility aid passenger uncomfortable during securement and release. The target for each is zero.

**13. & 14. The Number of Tools Needed to Connect/Disconnect Securement System**

These engineering requirements directly reflect similar customer requirements. The target for both of these requirements are zero, reflecting the desire to make the securement system easy to use.

**15. The Lateral Accuracy Required During Positioning of the Mobility Aid**

**16. The Longitudinal Accuracy Required During Positioning of the Mobility Aid**

**17. The Angular Alignment Accuracy Required in the Positioning of the Mobility Aid**

These three requirements are all measures of the customer requirement for easy positioning of the mobility aid. Initial consideration for measuring this requirement was the time it takes the mobility aid passenger to position the mobility aid for securement. However, there is such a diversity of mobility aid passengers and mobility aids that, without a large sample, any requirement on time would be impossible to measure with any accuracy. Thus, it was decided that a better measure was the positioning accuracy required for the securement system to operate properly. Since the position has three degrees of freedom, lateral, longitudinal, and angular positioning, there must be three measures for this requirement.

The target for lateral accuracy was based on two pieces of information. First, the clearance of the farebox gives some indication of the level of lateral control ability necessary to negotiate the mobility aid from the lift to the aisle on front load buses. This clearance can be as low as 2 in. (50 mm) for the base fleet of mobility aids. Second, the width of a typical wheel clamp is in 4 in. (100 mm). This is one competitive system used as a benchmark. Based on this data, the target is that the lateral alignment accuracy requirement should be  $\pm 2$  in. (50 mm).

The longitudinal alignment (fore/aft) accuracy was assumed the same. As design activity progressed, however, all designs proved insensitive to this requirement since mobility aids can easily be positioned longitudinally.

The amount of angular misalignment to use as a target proved difficult for the design team to determine. Initially, the target was set at  $\pm 10$  degrees based on consensus opinion of the designers. Later in the design process, actual measurements on a fixed route transit vehicle showed that backing a scooter into a securement area could result in a mobility aid misalignment of 25 degrees with the front of the mobility aid angled outward into the aisle. This misalignment is similar to that occurring when backing a car into a tight parallel parking space. Jockeying back and forth can lower the initial misalignment but, to keep securement as easy as possible, it was decided to disregard this. Note also that on a fixed route vehicle there is virtually no possibility of angular misalignment in the direction of the front of the mobility aid toward the wall. Thus, the target was increased to  $\pm 12.5$  degrees with the added consideration that the center line of this misalignment is angled toward the aisle 12.5 degrees.

#### **18. Number of Steps Needed to Secure**

The most critical of the customer requirements was found to be ease of connection as can be seen in the weightings in Figure 3. Thus it was imperative that a good set of engineering requirements be developed for this customer requirement. As in requirements 15, 16, and 17 above, time is one potential measure for the customer requirement, but was rejected for the same reasons. A better measure is the number of steps required to secure the mobility aid and the requirements on the mobility aid passenger to make these steps.

Here a step will be defined as one of four actions: 1) grasp or release; 2) move; 3) position and/or 4) engage. Each of these will be discussed in turn.

"Grasp or release" steps are the activities that are required for an individual to gain control of or transmit power to a device. Grasping is necessary before any of the other steps are undertaken with the exception of the use of a push button. In this case the button is moved without grasping any object. Release is not counted as a separate step as a release must always follow a grasp.

A "move" step implies a translation in a single direction or a rotation about a single axis. For example, a motion that requires an object to be moved forward 100 mm and then to the left 200 mm is counted as two steps. The same logic holds true for rotation.

A "position" step is like a move step except it requires fine motor control to get the object in a specific position. Positioning can often be difficult for a mobility aid passenger even though moving an object may not be. Thus, if in order for an object to be attached it must be in a specific location with a specific angular orientation, then this may require a series of move steps to get close and then a series of position steps to get it in the exact location and orientation. Positioning steps are for x-y orientation, angular alignment and rotational alignment. For example, consider the buckling of a belt. This requires a number of steps to move the tongue to the general vicinity of the buckle. Once there the tongue must be positioned in both the x and y directions, must be angularly aligned so that the tongue is roughly parallel to the slot

in the buckle (if it isn't already) and rotated to one of two opposing orientations about the axis of insertion so that the tongue will actually go in the slot.

The last type of step is called "engage". Continuing with the belt buckle example, after the tongue is fully aligned, a motion must be made along the axis of insertion to actually engage the tongue in the buckle.

The target for this requirement is zero steps. This may seem extreme; however, the EZ-LOCK system for personal vehicles achieves this target as does a wheel clamp. Thus, zero is a good target for this project.

#### **19. Number of Hands Required to Secure**

#### **20. Range of Motion Required to Secure**

These two requirements also help determine the ease of securement. As mobility aid passengers may have limitations in the use of and range of motion of their arms and hands, these are important considerations. Since the target for requirement 18 is that zero steps should be necessary for securement it follows that to actually secure should require no hand, torso, or head motion beyond that normally required to guide and propel the mobility aid.

#### **21 Use of Personal Restraint Possible**

The topic of personal restraint systems for mobility aid passengers is one of some debate. Thus, the design team decided that the use of a restraint systems must be an option, and the target for this requirement is a simple affirmative or negative.

#### **22. Securement System Interference with Personal Restraint**

This engineering requirement is an effort to measure the ease of utilization of personal restraint systems. It is a basic assumption of this project that the securement system shall be independent of the restraint system. This is because both transit companies and mobility aid passengers do not want to be forced to use restraint systems. Thus, the assumption is made that any securement system should not interfere with any restraint system that a mobility aid passenger may want to use with his/her mobility aid. This too is measured by a simple affirmative or negative.

#### **23. Number of Steps Required to Disconnect**

This requirement is measured in terms of steps as defined in requirement 18. The target for this requirement must be set at the minimum number of steps possible to disconnect an object. The design team assumed the best that is reasonably possible is for someone to push a button. The minimum number of steps to push a button is three. The hand or other object under control of the mobility aid passenger

must be positioned in the x and y direction (2 steps) and then moved (or engaged) in the z direction (a third step). Thus, the target for this requirements is three steps.

**24. Amount of Interference with Other Passengers when the Securement System is Not in Use**

**25. Amount of Interference with Other Passengers when in Use**

Both of these requirements have zero as their targets. Realistically, however, the securement of a mobility aid may displace passengers seated in the mobility aid station area. The securement system itself should be within this area when in use and not in use.

**26. Percent of Base Fleet that Fit the Securement System**

This engineering requirement is a measure of adjustability of the securement device. The base fleet that was described in engineering requirement 3 must be used in determining this measure. The target is that all of the base fleet be able to be secured with the device. Two more measures of the flexibility of the system are given next.

**27. The Number of Additional Parts Needed to Fit the Base Fleet**

This measure gives an indication of the complexity of changing the securement device from fitting one mobility aid to another. In this engineering requirement the term "parts" means separate parts or assemblies. The goal is zero in that the ideal device will fit all of the fleet without additional parts.

**28. The Number of Steps to Change Adjustment**

If there is need to add parts or adjust the securement device when changing from one mobility aid to another, then this measure gives an indication of the difficulty. The target for this measure is zero.

**29. Maximum Activation Time for Mobility Aid Passenger**

Although not a good measure of the ease of use of the securement system, the maximum activation time does give an upper limit to the complexity of the system. Based on discussions with the user group, two minutes from lift to securement was chosen as the target.

**30. Percent of Deceleration Force on Mobility Aid Transferred to Mobility Aid Passenger**

This measure is in response to the requirement for an optional passenger restraint system. It was noted on some of the video tapes of sled and accident tests that in some cases the passenger restraint system carried some of the load when the securement system failed or stretched. This means that some of the deceleration force on the mobility aid was transferred through the passenger. This measure is to insure that the restraint system and the securement system are independent. The target for this is that zero

percent of the deceleration load on the mobility aid should be transmitted through the passenger to the restraint system.

### **31. Amount of Change in Engineering Requirements when Wet**

This measure is in response to the customer requirement that the system work in all conditions. A good measure of this is how much the other system performance measures change when the securement system is wet. The target is for less than 15% change in any measure when the system is wet. This target is not based on any data, but seemed reasonable to the design team.

### **32. Amount of Change in the Engineering Requirements when in the Range of 0 to 110 Degrees Fahrenheit (-18 to 43 Degrees Celsius)**

This measure is similar to the previous one. Here the target is for the system performance to change less than 15% throughout the temperature range 0°F (-18°C) to 110°F (43°C). These temperature ranges seemed reasonable extremes to the design team. No standards for temperatures inside transit vehicles were found during the literature review.

### **33. Amount of Transit Operator Interaction with Mobility Aid Passenger**

This is a critical engineering requirement because one of the major customer requirements is that there be minimal dependence on the transit operator. This customer requirement was weighted quite high by mobility aid passengers and transit operators. Thus it was important to develop a good measure for this requirement. After observation of mobility aid passengers using the Lane Transit District and the TRI-MET systems it was concluded that the interaction requirements on the systems were greatly dependent on the capabilities of the mobility aid passenger. For the belt/wheel clamp systems observed the required interaction was anywhere from a simple visual verification by the transit operator to complete securement. Thus, a method was devised for evaluating the amount of interaction required for any securement system based on the mobility aid passenger capabilities. The method is represented in Table 3. The table delineates the amount of transit operator interaction.

Five different levels of functional use for mobility aid passenger, as defined in Table 4, were developed to assist with the design process. The classes range from a semi ambulatory mobility aid user to fully dependent mobility aid user. The functional ability column describes the most likely functional capabilities of an individual in a particular class. The mobility aid column describes the most likely type of mobility aid that an individual in a particular class would use. The numbers in the brackets refer to the number on the base fleet introduced in requirement 3.

TABLE 3. LEVELS OF TRANSIT OPERATOR INTERACTION

1	Securement system can be verified from transit operator station. (The transit operator does not move from the driving position).
2	Securement system must be verified at securement station. (The transit operator must leave the driving position but only for visual inspection.)
3	Transit operator must prepare station for use. (The transit operator must leave position and perform minimal physical effort.)
4	Transit operator must assist mobility aid passenger with less than 33% of the steps in securing and releasing the securement system.
5	Transit operator must assist mobility aid passenger with between 34 and 66% of the steps in securing and releasing the securement system.
6	Must assist mobility aid passenger with more than 67% of steps in securing and releasing securement system.

TABLE 4. FUNCTIONAL CLASSIFICATION OF MOBILITY AID USERS

Class	Title	Functional Ability	Mobility Aid
I	Walker	Limited use of legs, full use of arms, (M.S. or A.R.)	(5) scooter user, could transfer with difficulty
II	Para1	Full arm and hand use, no significant weakness, full use of head and neck	(1 and 2) use manual chair, or sport chair
III	Para2	Full arm and hand use, with significant weakness	(3 and 5) scooter or electric wheelchair user
IV	Quad1	Limited arm use, some hand function limited use of head and neck, may or may not have weakness	(1, 2, 3 or 4) manual or electric wheelchair user
V	Quad2	no arm use, very limited hand function or use, some head and neck motion, may or may not have weakness	(3 or 4) use power chair
<b>Mobility Aid Classifications</b> 1 Standard Manual Wheelchair 2 Lightweight/Sport Wheelchair 3 Standard Electric Wheelchair 4 Powered Base 5 Three-Wheeled Scooter			

Since systems like the EZ LOCK would take virtually no direct verification by the transit operator, the target for this project must be level 1 interaction regardless of the functional level of the mobility aid passenger.

#### **34. Amount of Modification to Mobility Aid**

Benchmark securement systems range from requiring no modifications (belts and wheel clamp) to the addition of brackets (EZ LOCK). In fact, there are four different levels of modification that are possible:

1. Permanent modifications which require welding, drilling, or other change not readily undone.
2. Addition of brackets or other items requiring tools such as wrenches or screw drivers.
3. Addition of brackets or other items that can be attached without the use of tools (e.g. with snap or velcro fasteners).
4. No modification or addition of brackets needed.

The target set by the design team was for no modifications.

**35. Fixed Route — Restrain for Acceleration Without Damage During Normal Operating Conditions**

**36. Demand — Restrain for Acceleration Without Damage During Normal Operating Conditions**

**37. Fixed Route — Restrain for Deceleration Without Damage During Normal Operating Conditions**

**38. Demand — Restrain for Deceleration Without Damage During Normal Operating Conditions**

**39. Fixed Route — Restrain for Cornering Without Damage During Normal Operating Conditions**

**40. Demand — Restrain for Cornering Without Damage During Normal Operating Conditions**

**41. Fixed Route — Restrain for Acceleration During Accident Conditions**

**42. Demand — Restrain for Acceleration During Accident Conditions**

**43. Fixed Route — Restrain for Deceleration During Accident Conditions**

**44. Demand — Restrain for Deceleration During Accident Conditions**

**45. Fixed Route — Restrain for Cornering During Accident Conditions**

**46. Demand — Restrain for Cornering During Accident Conditions**

The above 12 items are measures of the strength of the securement system. The primary function of the securement system is to secure the mobility aid and these 12 requirements are the primary measures of that ability. The load carrying capability requirement has been subdivided in three ways, by transit vehicle type, by force direction and by operating conditions. There are two types of transit vehicles considered in this study: fixed route and demand. It has been assumed that the fixed route vehicles have a gross weight of greater than 30,000 lb (13,600 kg) and operate on a set, scheduled route. Demand vehicles are lighter weight vans that respond to specific calls from mobility aid passengers and deliver them to a specific location. The division between these two types of vehicles and the operating conditions has been made because the demands on the securement system and the transit operator are different in each of them as are their performance envelopes in terms of stopping capability, cornering behavior and accident response.

A second division on the requirements for the load carrying capability of the securement system is the vehicle operating condition. There are two categories, normal operations and accident conditions. To date all standards have assumed accident conditions. However, it was noted during the development of these requirements that the conditions specified by the standards were virtually never reached in actual operation. Thus the team decided to list both accident and normal operating parameters. It should be noted that some of the currently used securement systems do not even meet the normal operating conditions, much less the accident condition requirement.

The third division on the requirements for the load carrying capability of the securement system is the direction of loading: forward (deceleration), to the rear (acceleration), and side ward (cornering or side impact situations). An extensive discussion of the load carry capabilities is included in the second part of Appendix D. These capabilities are given in Figure 5 for each vehicle type in each operating condition.

### **Design Loads**

The Federal Register Part IV Department of Transportation 49 CFR Part 38 Transportation for Individuals With Disabilities; Final Rule, dated Friday, September 6, 1991 (Americans with Disabilities Act(ADA) Accessibility Specifications for Transportation Vehicles, Subpart B - Buses, Vans and Systems) lists two different amounts of force that must be restrained, both in a forward direction only:

- for vehicles with GVWR's of 30,000 pounds or above, a force of 2,000 pounds per securement leg or 4,000 pounds per mobility aid;
- for vehicles with GVWR's of less than 30,000 pounds, a force of 2,500 and 5,000 pounds respectively.

The rationale for different standards based on size of vehicle is that smaller vehicles will experience higher acceleration g forces because of the lower mass of the vehicles and the mechanical design of the vehicles. The federal requirements do not specify how this force should be applied in a test situation, or how the test should be conducted. The word restrain is not specifically defined, but a dictionary definition implies that the mobility aid may not separate from the securement system as the result of forces listed above. A key phrase developed to describe this requirement is "there will be no structural separation between the mobility aid and the securement system during or after a worst case crash". It was the design team's interpretation that the securement system would need to hold and not release a mobility device when subjected to the worst-case load listed for a very short time period, such as during a simulated crash, and that the system would then be evaluated on a simple pass/no pass basis.

It should be noted that federal standards do not specify the condition of the mobility aid or the securement system after the application of such force. It is fully expected that after a crash they might be unusable, just as equipment in any other vehicle might be under the same circumstances.

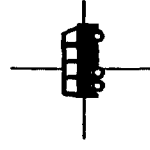
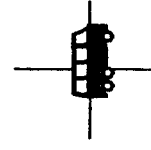
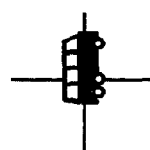
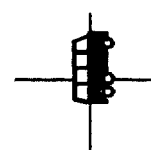

	Normal Operations	Accident
Fixed Route Vehicle	<p>0.4g</p> <p>0.1g</p>  <p>0.2g</p>	<p>10g</p> <p>2g</p>  <p>2g</p>
Demand Vehicle	<p>0.8g</p> <p>0.8g</p>  <p>0.8g</p>	<p>20g</p> <p>10g</p>  <p>10g</p>

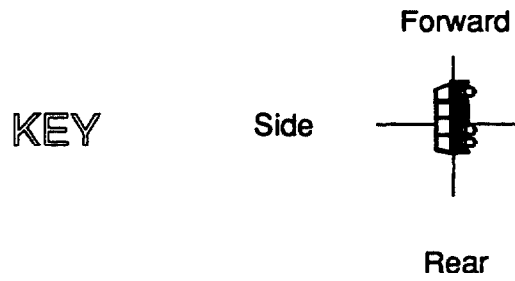

FIGURE 5. OPERATING CONDITIONS (g forces)

#### **47. Amount of Peak Acceleration Attenuated During Deceleration**

This requirement rose out of the desire of the design team to "cushion" any forward deceleration. Cushioning is effectively controlling the energy flow from the transit vehicle to the mobility aid. Thus, this is a requirement for taking the peak acceleration and distributing it over a longer time, at a lower peak level. The requirement is only for forward accidents as they appear to be the most likely. The target is to reduce the peak acceleration by 25%. This target is not based on firm data. Computer simulations, however, have shown that belt systems can actually increase the peak loads on the mobility aid.

#### **48. Maximum Longitudinal Motion of the Mobility Aid During Normal Operating Conditions**

Movement of the mobility aid relative to the transit vehicle gives the mobility aid passenger a feeling of insecurity. In the new American with Disabilities Act Regulations there is the requirement that the device should keep the motion to within  $\pm 2$  inches of fore/aft position. This was thought to be excessive by some members of the advisory committee and, for normal operations, the design team set a target of  $\pm 1$  in. (25 mm).

#### **49. Maximum Lateral Motion of Mobility Aid During Normal Operating Conditions**

Mobility aid passengers get a feeling of insecurity when their mobility aid moves relative to the transit vehicle during cornering. Thus, this measure is for the amount of relative motion allowed during normal cornering procedures. The Proposed Canadian Standard Z605 [3] allows  $\pm 1$  cm sideward deflection at the passengers center of gravity. Measuring at this location includes the stiffness of the securement system, the wheels, the mobility aid and seat cushion. The design team thought this value unrealistically small after observing mobility aids in transit vehicles. Thus the target was set at 1 in. (25 mm) measured at the combined center of gravity of the mobility aid and passenger.

#### **50. Maximum Tilt of Mobility Aid During Normal Operating Conditions**

This measure over-laps item 49 but measures the amount of tilt. The exact relation between the lateral motion of the center of gravity and the amount of tilt depends on the height of the center of gravity above the floor. To insure that the customer requirements are met an independent value is given for tilt. The target is  $\pm 5$  degrees.

#### **51. Percent of Interfaces that Use Overcenter, Surroundment, or Mechanical Interference**

This requirement is in some ways redundant. If the securement system can meet the other requirements then it should make no difference if the latches are overcenter, surroundment, mechanical interference or some other type. However, there is a customer requirement for latches that will not accidentally release so this is needed. Overcenter, surroundment and mechanical interference fasteners only

release through failure of the material or action of the user. They cannot release due to parts slipping over each other or through part flexure. The target is for 100% of the interfaces to be of these types.

**52. The Number of Soil Marks on Hands or Clothing per 100 Uses**

This measure is in response to the customer requirement that the device not soil hands or clothing. The only measure of this proposed is to measure the number of visible marks on hands or clothing per 100 uses in operation. The target for this is zero.

**53. Amount System Can be Tightened Beyond Required**

There has been a problem with belt type systems that can be over tightened and subsequently bend the mobility aid frame or wheels. Thus, there is the need to guarantee that the securement system force, while sufficient to meet the normal operation requirements cannot over load the mobility aid. The target is that at no time will the force on the mobility aid be greater than 120% of that caused by peak accident conditions.

**54. Minimum Radius of Any Edge**

To avoid injury, the minimum radius normal to the plane of the material on any sheet metal part shall be .01 inch (.2 mm). This target implies that all edges must be "broken".

**55. Minimum Radius on Parts**

To avoid injury, the minimum radius on any part shall be .01 in. (.2 mm). This target implies that all edges must be "broken."

**56. Percent Chemical Change During Lifetime**

The requirement is in response to the customer's desire that the securement system not rust. To insure a lifetime that is equal to that of the transit vehicles, there should be no visually discernable chemical change after five years of use.

**57. Maximum Protrusion From Floor When Not in Use**

**58. Maximum Protrusion From Walls When Not in Use**

**59. Maximum Protrusion From Mobility Aid into Aisle When Not in Use**

These three requirements reflect the desire to have a securement system that would be completely retracted when not in use, thus the targets are zero protrusions.

**60. The Number of Loose Parts**

One measure of the potential for vandalism is the number of loose parts. A target for this requirement is that the system should have no loose parts.

**61. Number of Delicate Parts Exposed When Not in Use**

Another measure of the vandalism potential is the number of delicate parts exposed or easily reached by other passengers. Thus this requirement is to minimize the amount of exposure to other passengers. The goal will be that no parts that can be made inoperable without the use of tools or easily reached by other passengers.

**62. Percent of Mobility Aid Types that are Forward Facing**

There is strong evidence from crash tests that passengers in side facing mobility aids are liable to greater injury in forward or rear accidents than those facing forward or aft. There is anecdotal evidence that most transit vehicles accidents are fore/aft in orientation. Since mobility aid passengers do not like facing backward, there is clear need to have all the mobility aids facing forward. The target then is 100%.

**63. Securement System Length Fore/Aft**

The USDOT ADA regulations [4] require that the fore/aft dimension of the mobility aid securement system be 48 in. (122 mm). Thus, the entire securement system must fit in this length.

**64. Securement System Width**

The USDOT ADA regulations [4] require that the width of the security station be 30 in. (76 mm). Thus, the securement system must be less than this wide.

**65. Cost per Securement System per Transit Vehicle**

The cost of the securement system can be borne by either the transit company or the mobility aid passenger. This measure is for the transit company and the following for the mobility aid passenger. The cost here is for the securement system installed in the transit vehicle. The target is \$800/vehicle. This is based on discussions with transit vehicle management.

**66. Cost Per Mobility Aid**

The cost of the securement system for each mobility aid is targeted to be zero.

#### **67. The Life of the Securement System**

The useful life of the securement system shall be equal to the transit vehicle in which it is installed. This target seems reasonable. Typically, the life of a fixed route vehicle is considered to be 12 years and the life of a demand vehicle is considered to be five to seven years. Thus, the target for this measure is 12 years.

#### **68. Percent of Mobility Aid Passengers That Like the Sturdiness**

The customers feel secure if the securement system appears to be sturdy. The only way to measure appearance is through a survey of opinions about the final product or of a model of the product. The target for this measure will be that 75% of mobility aid passengers should have the impression that the securement system looks secure. There is no good support for this value.

#### **69. Annual Preventative Maintenance Required**

To enable the securement system to last the life of the transit vehicle, it may require some preventative maintenance. Consideration of existing systems suggested a target of 20 min/station/year as a reasonable target.

#### **70. The Cost for Maintenance**

The cost for maintaining the system, counting time and material, shall not exceed 10% of the initial cost of the securement system per year. This value implies that system maintenance will cost its initial value over its lifetime.

#### **71. Time Increase to Clean Vehicle With Securement Station**

During the inspection of existing systems it was realized that some of them were very difficult to clean around due to having slots, loose belts or enclosed areas that can catch dirt. This requirement sets a target for the increase in total bus cleaning time of 1 minute per securement system.

#### **72. Percentage of Fleet that Can be Retrofitted**

Since transit vehicles have a lifetime of ten years, it is essential that any securement system design must be able to be retrofit into 100% of the currently used fixed route and demand vehicles.



## CHAPTER 5 - BENCHMARK DEVELOPMENTS

One value of the QFD method is that it encourages the evaluation of existing systems. This competition benchmarking is in step 4 and step 6 of the process. In step 4 the benchmarks are compared to the customer's requirements and in step 6 to the engineering requirements. In order to make this step manageable, all existing systems were represented by five examples:

Benchmark Device A: a single wheel clamp system that can be used on wheelchairs only.

Benchmark Device B: a three belt system that can be used on both wheelchairs and scooters.

Benchmark Device C: a wheel clamp and belt system that can be used on wheelchairs only.

Benchmark Device D: a center pin system that is used by mobility aid users who drive their own vans.

Benchmark Device E: a wheel bracket system which is proposed for use on wheelchairs only.

These five systems are shown in Figures 6 through 10.

As shown in Figures 6-10, each of these systems were compared to the customer requirements (shown in Figures 2,3, and 4) using the 5-point system described earlier. Although this rating should be accomplished by the customers, logistics did not allow for this. Thus, two members of the design team independently rated each system. Their initial agreement was greater than 75%. The remaining 25% were discussed until the compromise ratings shown were agreed to.

In the current study the benchmarks were not completely compared to the engineering requirements. Some measurements would require actual sample and testing. Time did not allow for such testing.

In comparison to the customer requirements the goal was to see if any of the present devices met all the requirements and to find the device(s) that met a minimum acceptance threshold. If one or more of the devices met the customer requirements then the search for a universal securement system is ended. But if none of the benchmark devices measured up to what the customer required, then the search for a better device would continue. After a new devices had been designed, the benchmark devices were used to compare the new design against the benchmark designs to quantify that the newer device is better or met the customer requirements. None of the above benchmark devices met the most important customer requirements of capable of being used for all commonly used mobility aids, passing the crash testing requirements or movement limits of the new regulations, and complete user 'ease of use'. A device that would meet all of the customer requirements would score 5's in all row items down its respective column. No existing device was rated as fully meeting all the customer requirements. Certain devices scored higher in some areas than others, indicating their specific design strengths. The conclusion from this comparison was that there was no present device that could be considered as a universal securement. This gave the design team the go ahead to start with new design idea generation. The device (center pin device D) that scored the highest in this comparison formed the basis for a starting point of new idea generation.

BENCHMARK DEVICE -A-

WHEEL CLAMP ONLY

APPLICATION: WHEEL CHAIRS ONLY

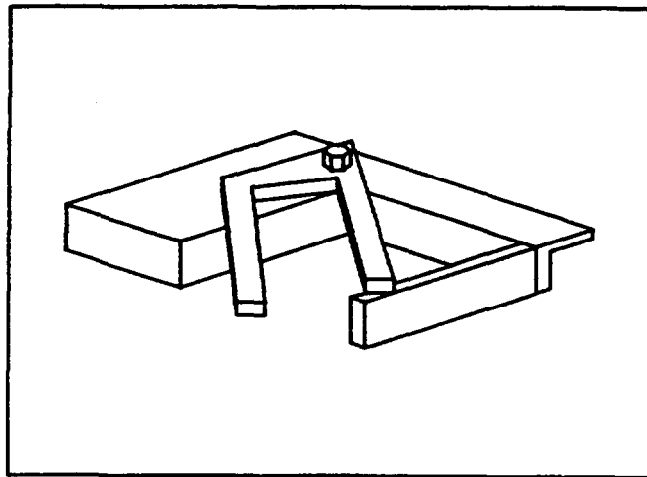

DESCRIPTION: A MECHANICAL DEVICE  
THAT HOLDS WHEEL  
INTO CLAMP

FIGURE 6. WHEEL CLAMP ONLY



BENCHMARK DEVICE -B-

THREE BELT SYSTEM

APPLICATION: WHEEL CHAIRS AND SCOOTERS

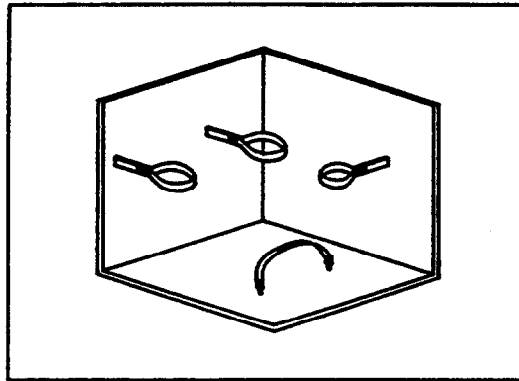

DESCRIPTION: WHEEL CHAIRS--TWO BELTS ATTACH TO ARM FROM REAR AND ONE BELT ATTATCES TO ARM FROM SIDE

SCOOTERS--TWO BELTS ATTACH TO SEAT POST FROM BEHIND AND ONE BELT COMES ACROSS FLOORBOARD

FIGURE 7. THREE BELT SYSTEM

BENCHMARK DEVICE -C-

WHEEL CLAMP AND BELT

APPLICATION: WHEEL CHAIRS ONLY

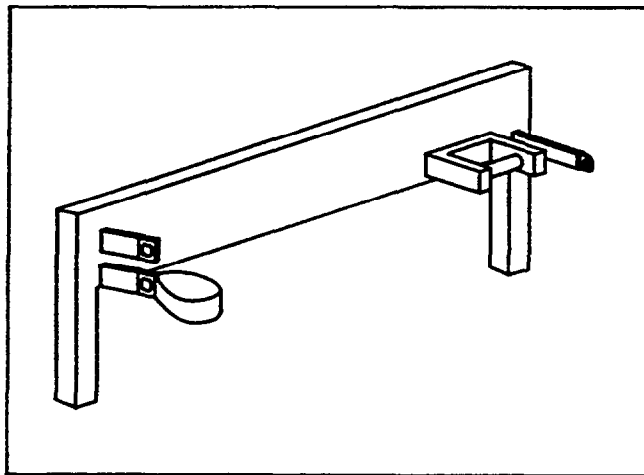

DESCRIPTION: CLAMP ON OUTSIDE WHEEL  
AND BELT ON INSIDE  
ARMREST SUPPORT

FIGURE 8. WHEEL CLAMP AND BELT

BENCHMARK DEVICE -D-

CENTER PIN

APPLICATION: CURRENTLY WHEELCHAIRS ONLY  
POSSIBLE USE ON SCOOTERS

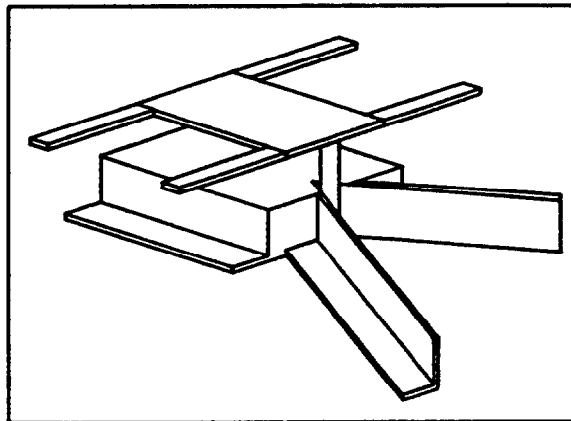

DESCRIPTION: DEVICE BOLTED ONTO  
WHEELCHAIR AND MATING  
DEVICE ON TRANSIT VEHICLE

FIGURE 9. CENTER PIN

BENCHMARK DEVICE -E-

WHEEL SECUREMENT BRACKET

APPLICATION: CURRENTLY WHEEL CHAIRS

POSSIBLE SCOOTER APPLICATION

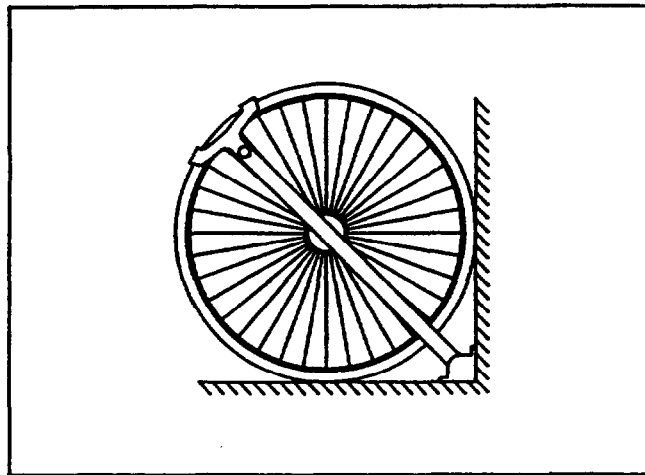

DESCRIPTION: BRACKET THAT CLAMPS  
OVER WHEEL

FIGURE 10. WHEEL SECUREMENT BRACKET

## CHAPTER 6 - CONCLUSIONS AND RECOMMENDATIONS

### Value of Method and Results

The QFD method was used to aid in developing an understanding for the securement system problem. The effort to develop the customers requirements led to a closer relationship to and respect of the advisory committee. It also led to an increased understanding by the designers and advisory committee of what the securement system needed to accomplish.

The development of the engineering requirements and targets was probably the most beneficial part of the effort. The need to generate measurable requirements forced deeper research into the operation of securement systems and interfaces with mobility aid passengers.

The effort to benchmark the competition, although somewhat shortened, generally helped gain an understanding of the strong and weak points of existing systems.

Finally, one unexpected value of the method was the development of clear information for communication to the advisory committee and the sponsors. At meetings where the QFD matrix has been displayed, the design team found that they could easily communicate what they had considered and what assumptions they had made.

Successful future modification to any design requires that the current design engineer know the rationale behind decisions of the original design. With the detailed development of the above engineering requirements, all future devices and their modifications will now have a set of design standards to which changes must be compared.

### Conclusions

This report has discussed the application of the QFD method for the development of the OSU Securement System. The QFD method has permitted the design team to approach an ill defined and complex design problem systematically and orderly. The QFD method forced the designers to clearly define the "Customer" and this is the first step is understanding the problem. In this particular application of the QFD method the "Customer" was represented by an Advisory Committee. The Advisory Committee provided strong direction and guidance for the project at a number of important stages of the problem definition phase. Initially, the advisory committee assisted with the development of the matrix, specifically the development of all the customer requirements. The advisory committee also assisted with establishing the design priorities and the calibration of the matrix.

There have been no changes in the design concept since its inception, however there have been many design refinements. The advisory committee's input strongly directed the design of the securement system. The resulting design is sensitive to the requirements of all the "Customers" and more important, it has been widely accepted by the "Customers".

This report documents the successful application of the QFD approach to the design of a mobility aid securement system. The use of this report, together with references documenting the QFD process provide useful information on the QFD approach to design.

### **Recommendations**

The application of the QFD method to the development of the Independent Locking Securement System has shown both the potential and power of this design process. The QFD method forces the designers to fully understand the problem before development of design concepts begins, and it also promotes the development of a body of design knowledge that can be used by others approaching the same or similar design problems. The QFD method insures that the needs of the customer are integrated into the design. The OSU design team is also using the QFD method to develop a passenger restraint system that will be used with the OSU securement system.

## CHAPTER 7 - REFERENCES

An extensive resource library was developed to support the research necessary for the QFD method. The resource materials were organized into a reference base, and a brief summary of each item was incorporated into the reference base. The reference base is included in Appendix A. It is organized into: Reports (general), Technical Literature (general), Unpublished Reports, Standards, Crash Tests, Devices, and Videos. All vendor references have been omitted from this report. The references listed below pertain directly to the preparation of this report.

1. Ullman, D.G. "The Mechanical Design Process," McGraw Hill, New York, 1992.
2. Hauser, J.R., and Clausing, D., "The House of Quality," Harvard Business Review. May/June 1988. pp 63-73.
3. CSA Standards Z605 (draft), "Mobility Aid Securement and Occupant Restraint (MASOR) Systems for Motor Vehicles," Canadian Standards Association, Rexdale, Ontario, Canada, April 1991.
4. Architectural and Transportation Barriers Compliance Board (ATBCB), "American with Disabilities Act (ADA) Accessibility Guidelines for Transportation Vehicles," 36 CFR Part 1192, Federal Register Vol. 56 No., 173, September 6, 1991.
5. B.C. Transit, "BC Transit Barrier Crash Tests of 3-Wheeled Scooters and Wheelchairs in Paratransit Vans," Final Report, May 1990.
6. Booz, Allen Applied Research, "Bus Interior Design for Improving Safety," Transbus Document TR 76-001, U.S. DOT, Urban Mass Transportation Administration, Washington, DC, 1976.
7. Fowkes, M., Smoczynskiz, J., "The Restraint of Wheelchairs and Wheelchair Occupants on Public Transportation," The Motor Industry Research Association, Nuneaton, England, 1987.
8. Hunter-Zaworski, K. M., "Securement of Non Traditional Wheelchairs on Public Transit Vehicles," Final report for TRANSNOW, Seattle, WA, September 1990.
9. Hunter-Zaworski, K. M., "The Status of Wheelchair Occupant Restraint Standards for Motor Vehicles: Transportable Devices," Transportation Research Board Annual Meeting, Washington, DC, January 1990.
10. Layton, R., Hunter. K., and Safford, R., "A Study of Human Factors in Public Transportation Safety," Final Report, U.S. Department of Transportation, Urban Mass Transportation Administration, Washington, DC, March 1989.

11. "National Workshop of Bus-Wheelchair Accessibility," Guideline Specifications for Active Wheelchair Lifts, Passive Wheelchair Lifts, Wheelchair Ramps, Wheelchair Securement Devices", Office of Technical Assistance, Office of Bus and Paratransit Systems, USDOT, Urban Mass Transportation Administration, May 7-9, 1986.
12. Project ACTION, "Reconnaissance Survey of Selected Transit Agencies" Washington, D.C., June 1990.
13. Project ACTION, "Combined Research Results" Washington, DC, June 1990.
14. RESNA/ANSI Wheelchair Standards Draft of, "Guidelines for Application of Wheelchair Standards (ISO/7176)," Revised May 1988, RESNA, Washington, DC.
15. Standards Association of Australia, "Wheelchair Occupant Restraint Assemblies for Motor Vehicles," AS 2942-1987, North Sydney, 1987.
16. Todd, Sheldon, P., Ed., "Choosing a Wheelchair System," Journal of Rehabilitation Research and Development-Clinical Supplement No. 2., Department of Veterans Affairs, March 1990.
17. NASA (1978). "Anthropometric Source Book", 3 vols., (NASA Reference Publication 1024). Houston, TX, NASA.
18. Croney, John, "Anthropometry for Designers", Van Nostrand Reinhold Company, New York, 1981.
19. SAE J992, Mar 85, Brake System Performance Requirements - Truck, Bus and Combination Vehicles
20. Mercer W. And J. Billing "Assessment of a Transportable Mobility Aid in Severe Driving Conditions - An exploratory Test," Report CV-90-03, The Vehicle Technology Office, Ministry of Transportation of Ontario. Dec 1990.
21. Edwards, Amelia. "Handicapped Accessible Public Transportation: Mobility Device Lifts and Restraints," Masters Project Report, Civil Engineering Department, Oregon State University, June 1991.



**APPENDIX A**  
**LITERATURE REVIEW: Annotated Bibliography**



## APPENDIX A

### LITERATURE REVIEW: Annotated Bibliography

The Annotated Bibliography includes the following materials: reports (general), technical literature (general), unpublished reports, standards, crash tests, devices, and videos. The Ref ID # refers to the internal reference file system. Vendor materials were also filed but they have not been included in this report.

#### REPORTS (GENERAL)

1. **--Changing Times-- Needed Modifications in Public Transit Operations and Equipment to Ensure Accessibility of Handicapped and Disabled Persons --A Review of Wheeled Assistance Devices--**. 1989.

Ref ID #RP5

Keywords: PUBLIC TRANSIT, ACCESSIBILITY, handicapped, DISABLED

Notes: This paper does not extol the gains of public transit but instead asks or suggests that transit systems continue their push forward to position themselves for the twenty-first century. The move forward is to extend to the most physically disadvantaged the thrill of independent travel. In the pages that follow are:

- a) A listing of policy recommendations
- b) A brief background and perspective on accessible transit issues
- c) A summary of an Oregon-wide transit agency "wheeled assistance device" survey.

Regrettably, the key recommendation is not without cost. Furthermore, these costs must be considered in the context of continued growth in demand for work trip travel, increased services to suburban areas, and renewed calls for greater contributions for public transit to solve traffic congestion, energy and air quality problems. Its in this context that the need for a comprehensive transportation financing package for Oregon's transit and highway system becomes paramount. It may, after all, rank second in importance only to school financing reform. Deteriorated road networks, foregone opportunities to make critical capital improvements, and increased basic transportation needs warrant aggressive legislative action. The Oregon Transit Association Board appointed the Technical Assistance Committee at the 1988 OTA Conference. The Board asked that the Committee members collaborate to develop a recommended policy for consideration by the Board and the public transit community in general. This report is the culmination of those efforts.

2. Smith BA. **Wheelchair Securement and Passenger Restraint: Issues, Principles and Initiatives**. 1987.

Ref ID #RP6

Keywords: WHEELCHAIR, securement

Notes: This packet contains overheads and a report that has been given at many places; it provides an understanding of the problems associated with wheelchair securement and passenger restraint and the basic principles that must be recognized if safe wheelchair vehicle interface is to be provided. It includes:

1. A brief R&D overview;
2. An update on TDC's current work;
3. A discussion of the 4 basic securement principles;
4. A look at several available securement systems;
5. The current situation;
6. Some future initiatives.

3. **Edwards A. Handicapped Accessible Public Transportation: Wheelchair/Scooter Lifts and Restraint Devices.** 1990. Masters Thesis, Civil Eng. Dept. OSU.

**Ref ID #RP1**

Keywords: handicapped, PUBLIC TRANSPORTATION, WHEELCHAIR, lift, RESTRAINT DEVICE, ACCESSIBILITY, scooter

Notes: Transit agencies have slowly begun to recognize the public transit needs of the handicap community. This section of the population, in general, must rely heavily upon public transportation to move through the community. In accommodating the needs of the handicapped and disabled community, public transit agencies experiment with and test the existing technology and develop new technology to best serve these people. Since the first accessible bus system became available in San Diego in 1977, public transit has made a great deal of progress. Transit agencies are slowly becoming handicap accessible. With the accessibility issue, comes a new set of problems: changes in the law, lifts, securement devices, and modifications.

4. **Henderson. Safety Analysis of Mobility Aids: A Proposed Method for Use by Transportation Systems.** 1990.

**Ref ID #PP3**

Keywords: mobility aid, transit system

Notes: In recent years several manufacturers of mobility aids have clearly stated in their owners manuals not to ride on their products while on moving vehicles because its unsafe. Some manufacturers of securement products state their devices are only intended to stabilize a mobility aid under normal driving conditions. Presumably normal driving does not include panic stops, collisions, running into deep "chuck" holes or poor driving habits such as cornering too fast.

Transportation programs are under increasing pressure to transport persons with all kinds of mobility aids. Many aids are unsafe or cannot be safely secured with securement devices used by a given transit system. Until such time when appropriate standards and specifications are available something needs to be done. An interim solution is to propose the use of a simplified systems approach to examining specific mobility aids in order to arrive at a conclusion concerning the ability of your transportation system to safely transport them. The approach suggested is merely a concept, it is not intended to serve as a definitive process, but it can be a beginning.

5. **Maxwell, Jane. Wheelchair Safety Securement System Demonstration and Evaluation.** Final Report # 4500-295-RI. Brobeck Corporation. 1986.

**Ref ID #TP14**

Keywords: wheelchair securement systems, public transit vehicle, prototype, securement devices and brackets, wheelchair participants

Notes: Final Report July 1984-July 1986 A system for securing wheelchairs on public transit vehicles has been developed consisting of a device placed within the floor of a vehicle and brackets fitted to the wheelchairs to be secured. It is actuated by the wheelchair patron. A prototype of the system has been dynamically tested and demonstrated with favorable results. This report describes a project for manufacturing several of the systems and installing them on transit vehicles and wheelchairs for exposure and demonstration to the public. Evaluation of performance and acceptance was made and recommendations developed for use of the system. The project work of writing the specifications, fabrication, and installation of the systems, and evaluation of their use was contracted to Brobeck Corporation, and engineering consultant. The evaluation of the system concludes that it works well for wheelchairs that are retrofittable but it is only compatible with about one-fifth of the available chairs. Further, there are drawbacks to the maneuverability of retrofitted chairs and of all chairs on retrofitted transit vehicles and wheelchairs would have to be standardized as to configuration for the system to be accepted by those whom it is intended to serve.

6. **Wheelchair and Safety Tie-Down Procedures for Physically Handicapped Transportation. Bus Us Safely.** Portland Public Schools Student Transportation Department. 1987.

**Ref ID #RP2**

Keywords: WHEELCHAIR, handicapped, standard

Notes: In a continuing effort to insure the safety of physically handicapped students using the Portland Public Schools Transportation System, the Safety/Training section has upgraded requirements and procedures for bus and wheelchair equipment safety. The catalog provided services a variety of functions. – Provides recommendations for parents in their choice of wheelchairs and equipment, and when applicable, prescribes certain standards. It is hoped this will prevent the costly mistake of purchasing equipment not suitable for transport.

Wheelchair types are divided into two sections, "Acceptable" and "Unacceptable" for transportation. Both sections list specifications, special features, and bus-attachment procedures for chairs. – Presents to the drivers a variety of chair and equipment-types that can be encountered on their routes, and provides specific instructions for attaching chairs safely to the bus. – It informs the public as to what steps are being taken to provide safe transportation for physically handicapped students. – Provides a tool for sales persons and manufacturers in the wheelchair industry to use when helping a parent make a decision in purchasing chairs and equipment.

7. Hunter-Zaworski KM. **Securement of Non-Traditional Style Wheelchairs on Public Transit Vehicles.** Final Report. TRANSNOW, University of Washington, Seattle. September 1990.

**Ref ID #RP13**

Keywords: transportability, WHEELCHAIR, SECUREMENT/RESTRAINT system, occupant securement, fixed route, paratransit, pupil transportation, B.C. Transit, UMTA, Project ACTION, TRI-MET

Notes: The problem of accommodating wheelchairs on public transit vehicles is not a new one, but the problem has been compounded by the increase in the number of mobility aid styles. Wheelchairs have evolved from being wheelchairs to mobility devices or aids. The problems of accommodating mobility aids on public transit vehicles has become a major issue as mobility aid technology has changed, and the Americans with Disabilities Act (ADA) will force public transportation to become fully accessible to all persons.

The major problems faced by transportation agencies is the legal requirement to transport all persons, but at the same time a lack of appropriate technology to safely secure the mobility aids. A conference was designed and held with the intention of providing a forum for discussion on how to solve some of the problems related to providing accessible transportation, in light of the new Federal Regulations and the technical challenges posed by the new mobility devices.

8. Layton R, Hunter-Zaworski KM, Safford R. **A Study of the Human Factors in Public Transportation Safety.** Final Report. USDOT/UMTA, Washington, DC. March 1989.

**Ref ID #RP15**

Keywords: WHEELCHAIR, transit system safety, passenger safety, driver safety

Notes: The overall goal of this research was to apply a systematic approach to the investigation of the effects of human factors on safety in public transportation. The research focused on safety of fixed route bus operations. Human factors related to both drivers and passengers were examined with special emphasis given to safety problems for handicapped and elderly passengers. The bus cockpit design and layout was identified as a major problem for driver safety, in the short term and over the long term. An in-depth analysis of the human factors effects and impacts of the bus cockpit design was undertaken. A major problem identified and analyzed in depth for passenger safety was the use of powered scooter-type wheelchairs. constrained schedules were identified as significant potential contributors to safety for both drivers and passengers.

9. **National Workshop on Bus-Wheelchair Accessibility: Guidelines.** 1986.

**Ref ID #RP4**

Keywords: ACCESSIBILITY, paratransit, transit agencies, UMTA, handicapped

Notes: On September 17, 1985, the Administrator, Ralph L. Stanley, of the Urban Mass Transportation Administration, called together a meeting with representatives of transit agencies, handicapped organizations, rehabilitation specialists and manufacturers of buses and wheelchair lifts to hear first hand the problems and issues regarding transit bus wheelchair accessibility. As a result of this meeting, the Administrator requested that an UMTA Advisory Panel be formed to plan a National Bus Wheelchair Accessibility Workshop and to guide the development of a set of guideline specifications for the equipment required for transit bus and paratransit vehicle wheelchair accessibility. A contract was issued to Battelle to assist UMTA in this effort.

As a result of surveying the transit industry for input and meeting with the Advisory Panel, Battelle prepared a draft set of guideline specifications for wheelchair lifts, securement devices and ramps for presentation and discussion at the National Bus Wheelchair Accessibility Workshop held in Seattle, Washington, on May 7 through 9, 1986. Using the inputs developed during the Workshop and the written comments submitted following the Workshop, the Advisory Panel prepared these final guideline specifications. These guideline specifications are advisory in nature. The intention of the guideline specifications is to provide transit agencies with a model that they could use, as appropriate, in the development of their specifications for wheelchair accessibility.

In the guideline specifications, where the word "should" is used, the recommendation of the Advisory Panel is that the suggested item or value be included in a general specification. Where the word "may" is used, the recommendation of the Advisory Panel is that the item or choice of values be considered for inclusion based upon local operating conditions. The Advisory Panel has developed these guidelines for use throughout the United States. It recognizes that unique local conditions could make an item suggested for inclusion inappropriate and a local public transportation provider would be required to make the appropriate changes (e.g. to accommodate extreme environmental conditions).

This guideline specification is one of four specifications developed by the Advisory Panel, which developed separate guideline specifications for passive wheelchair lifts (those used primarily on transit buses), active wheelchair lifts (those used primarily on paratransit vehicles), ramps and securement devices. Members of the Advisory Panel participated actively in the development of each individual guideline specification based upon their experience and interest. Although the Advisory Panel discussed many related accessibility issues, these guideline specifications focus only on the technical requirements of a specific piece of equipment. They have been prepared to assist in the purchase of such equipment either separately or as part of an overall vehicle procurement.

10. **Hunter-Zaworski KM, Guthrie, BM. Wheelchair Occupant Protection Systems in Vehicles: A Strategy for the Development & Diffusion of Standards.** Hickling, 1989.

**Ref ID #ST9**

Keywords: WHEELCHAIR, OCCUPANT, securement, transportability

Notes: Operators and users of specialized transportation systems in Canada require immediate assistance in assessing the safety of transporting wheelchair users. A coordinated effort in the development of wheelchair occupant protection systems (WOPS) is required. (WOPS include consideration of wheelchair securement, occupant restraint and transportability of the wheelchair itself). This paper sets out a strategy for the development of Canadian standards for WOPS for vehicles in general, and public transportation systems in particular. The proposed strategy addresses technical, operational and organizational aspects, as well as the issues of diffusion and acceptance of the standard.

11. **Schneider LW, Benson J. Improving the Crashworthiness of Restraint for Handicapped Children.** SAE Technical Paper Series. 1984; 404:398-404.

**Ref ID #TP17**

Keywords: handicapped, RESTRAINT

Notes: As a result of improved educational opportunities, handicapped children have increased exposure to transportation related risks. Many of these children require specialized orthopedic seating and posture

control devices and must remain in them while riding in a vehicle. The lack of impact protection features in these seating devices introduces an unnecessary level of risk. The emphasis of this program was to demonstrate that proven restraint principles could be applied to handicapped seating without compromising the medical requirements of these units. Efforts were concentrated on two such systems: a molded-shell orthotic seat and a stroller-type Travel Chair. Sled impact tests at 30 mph and 20 g's were used to assist in the evaluation of the upgraded restraints. The results have been encouraging and have shown that handicapped seating can supply the same level of crash protection provided by conventional child restraint systems.

12. Shelness A. **Transporting Children with Special Needs, part II: Protecting Handicapped School Children.** Safe Ride News. 1987; VI, No. 3:1-8.  
Ref ID #RP30

Keywords: handicapped, RESTRAINT DEVICE, pupil transportation, WHEELCHAIR

Notes: This article is the concluding part of a comprehensive two-part report describing the problem and state of the art of transporting children with disabilities.

13. Blanchet R, Bety J. **Compendium of Accessible Vehicles.** Transport Canada. 1988; TP7310E.  
Ref ID #RP16

Keywords: ACCESSIBILITY, DISABLED

Notes: This compendium provides detailed information on a selected number of accessible vehicles available in North America. The compendium is organized into eight vehicle categories: personal car, taxi, mini-van, van, body-on-chassis vehicle, small bus, large bus, and articulated bus. Vehicle descriptions include technical specifications, available accessibility options, and photographs or drawings. Supplementary material includes a selected bibliography and a list of vehicle manufacturers and converters. Information in this compendium will assist prospective vehicle buyers to choose a suitable accessible vehicle by matching vehicle specifications with their particular requirements.

14. Smith BA, Nishizaki RS. **Compendium of Transportation Equipment for Disabled Persons.** Transport Canada. 1981; TP 3618E.  
Ref ID #RP17

Keywords: WHEELCHAIR, lift, securement

Notes: This year, the International Year of Disabled Persons, public attention has focused on the issue of accessible transportation for the disabled. Among the myriad of problems associated with the provision of accessible transportation services is the acquisition of suitable equipment. In the first place, developers and manufacturers of specialized equipment are neither numerous nor well known to the public, and, secondly, the consumer is uninformed. Contributing factors are market uncertainty and fragmentation, high cost/risk, and lack of information.

Legislation of safety standards for equipment used in vehicles to transport disabled persons would create a guaranteed market for specialized equipment meeting the standards. A guaranteed market would also mitigate the cost/risk factor associated with the development and manufacture of new and improved products. Lack of information is a problem for everyone involved in the field of transportation for the disabled persons. Developers and manufacturers do not have full access to equipment testing results, and new concepts in design do not receive full exposure.

Lack of information is of special concern to consumers who must compare and then select equipment best suited for their purposes, without a comprehensive data base upon which to draw. This compendium has been prepared by the Transportation Development Centre of Transport Canada with the objective of providing a comprehensive source of detailed information on specialized equipment currently on the market or in the prototype stage. The data contained in the compendium has been collected and synthesized from a variety of sources in North America and abroad. Sources include equipment manufacturers and suppliers, researchers and developers, operators and planners of special transportation services, consumer groups, workshops, conferences and government agencies. Because wheelchairs present the most significant accessibility problem, emphasis has been placed on equipment designed to provide accessible transportation for the wheelchair user.

The compendium is organized in four main sections for easy reference: \*wheelchair lifts \*wheelchair securement \*non-conventional wheelchairs \*wheelchair loaders. Each section features: \*description of the device or system \*summary table of equipment characteristics \*data sheets \*photographs or drawings. Supplementary material supplied includes: \*list of manufacturers/developers \*manufacturer/equipment summary table \*glossary \*selected bibliography.

15. Douglas Ball Inc, Rutenberg U. **Wheelchair Tie-Down/Passenger Seat Prototype Development.** Transport Canada. 1978; TP1821.

**Ref ID #RP11**

Notes: This report outlines the development of a wheelchair tie-down system for use in rail passenger cars. Originally, the project was to incorporate a combination seat/tie-down, but space limitations resulted in the assigned area to be used exclusively for the wheelchair tie-down. The requirements of disabled passengers are given, and the development is followed through to the fabrication of two prototype systems for testing. Drawings and specifications of the prototype system are included, as well as photographs.

16. Douglas Ball Inc, Rutenberg U. **Multimodal Wheelchair Securement/Passenger Restraint Prototype Development.** Transport Canada. 1981; TP3057E.

**Ref ID #RP12**

Keywords: WHEELCHAIR, securement, tie-down, passenger restraint, handicapped

Notes: This report outlines the development and testing of a prototype wheelchair securement/passenger restraint system. The modular system consists of arms, which engage the wheels to secure the wheelchair against the back structure of the system, and a three point belt system to restrain the wheelchair user. The system is applicable to multimodal use with the exception of the air mode. The report describes the construction of the prototypes, laboratory strength testing and in-service operational evaluation.

17. Douglas Ball Inc, Rutenberg U. **Wheelchair Restraint System Design for Multi-Modal Transportation.** Transport Canada. 1979; TP2179

**Ref ID #RP10**

Keywords: WHEELCHAIR, RESTRAINT DEVICE, handicapped

Notes: This report outlines the development of a concept for a wheelchair restraint system to be used in almost all transportation systems. Originally this equipment was destined solely to vans and small buses, but it soon became evident that other transportation systems, although different in some of their characteristics, presented sufficient similarities to permit extending and expanding the concept to incorporate them into the original thinking. Therefore, a modularized system was developed to satisfy these different needs; from the simple task of immobilizing the chair to a complete safety unit. Preliminary drawings and photographs of a model of the system are included as well as a description of the concept.

18. Garland LA, Dorion SL, Vietinghoff HE. **Development of a Standard Interface Concept for Securing Wheelchairs in Accessible Vehicles.** Transport Canada. 1989; TP9734E

**Ref ID #ST30**

Keywords: wheelchair securement system, standard interface, WHEELCHAIR, DISABLED, handicapped

Notes: The continuing evolution of wheelchair design, which has resulted in a wide variety of sizes and shapes of wheelchair, has created a problem for accessible transportation systems. Currently, no standardized method exists for securing wheelchairs in accessible vehicles; thus, in many cases the securement system available is not compatible with the wheelchair being transported, and system accessibility is adversely affected. This report describes the development and evaluation of a concept for a standard interface to be used to allow wheelchairs to be secured in accessible vehicles. The report details the technical feasibility, the physical and performance requirements, an ergonomic evaluation and an economic impact evaluation of the standard interface.



19. Duffey TM, McLaurin CA, Thacker JG. **Construction and Operation of the ISO Double Roller Fatigue Test.** University of Virginia Rehabilitation Engineering Center. 1986; UVA-REC-107-86.  
**Ref ID #TP8**

Keywords: ISO

Notes: A small, inexpensive machine for performing fatigue tests on wheelchair frames in accordance with ANSI and ISO wheelchair standards was designed, constructed, and tested. A description of this device, the materials and hardware needed to construct it, and detailed assemble and operating procedures are presented. Also included is a comparison of strain and acceleration data obtained from a wheelchair that was tested on both the fatigue tester and a treadmill. Detailed part and assemble drawings are included in the Appendix.

20. United States Architectural & Transportation Barriers Compliance Board. **Lifts and Wheelchair Securement.** US ATBCB. 1991.  
**Ref ID #TP9**

Keywords: WHEELCHAIR, lift, ACCESSIBILITY, securement device, UMTA

Notes: This technical paper is a companion document to the Guideline Specifications developed by an industry Advisory Panel sponsored by the Urban Mass Transportation Administration (UMTA). The Guideline Specifications, developed by consensus, provide not only industry recommended minimum dimensions and guidance but discuss many of the technical issues related to accessible transportation. The Architectural and Transportation Barriers Compliance Board (ATBCB), which provided technical assistance to the Advisory Panel, has not formally endorsed the Guidelines but recognizes their value to the industry. This technical paper discusses some issues not found in the Guideline Specifications and is intended to stimulate discussion and examination of important accessible transportation issues. The purpose of the paper is not to provide definitive answers. Communities, through local decision making processes, must decide which of the specific guideline recommendations should be adopted to ensure the most accessible transportation to meet the needs of the disabled community. Information, and resources to obtain further information, are presented to assist local entities in this decision making process. Experience shows that, with improper planning or implementation, accessible transportation can appear to be an operational failure. Experience has also shown, however, that properly planned, implemented, and operated accessible transportation contributes to a better community.

## TECHNICAL LITERATURE (GENERAL)

21. Wevers HW. **Wheelchair and Occupant Restraint System for Transportation of Handicapped Passengers.** Archives of Physical Medicine & Rehabilitation. 1983. Vol. 64.  
**Ref ID #TP13**

Keywords: wheelchair restraint

Notes: The objective of research into restraining wheelchair-bound passengers of buses and vans, was to design an effective system that can be built with standard components at reasonable costs without interfering unduly with passengers and space requirements. The author consulted with rehabilitation medicine and transportation specialists and found that virtually all current systems are ineffective in either restraining wheelchair, occupant, or both under conditions of impacts at 50km/h and less. Many systems may appear technically sound, but contain weak links, thus rendering the whole system useless or making it dangerous. A system was designed that utilizes off-the-shelf components and especially designed channels. The assembly has been tested under static conditions in the laboratory by applying a pull of 6000 newtons (N), according to static test procedures standardized by the Society of Automotive Engineers (SAE) for seatbelts. Furthermore, the system was dynamically tested in a crash test at 50km/h. The system is currently used in a private van, a public van offering 5 seating positions, and a school bus designed for 17 wheelchair positions.

22. **Schneider LW. Transportation of Wheelchair-Seated Students. In: Seating Systems, Orthotic Devices, and Transportation Safety. 1991:151-164.**  
**Ref ID #RP26**

Keywords: DISABLED, wheelchair restraint, Q'Straint

Notes: ...For the student who is disabled, however, and especially those students who travel seated in wheelchairs and other mobile seating devices, the transportation situation is quite different. Not only do these students frequently travel over longer distances and in smaller buses and van-sized vehicles, thereby increasing their exposure and risk to vehicle accidents, but they are often transported without any effective provision for protection in the event of a vehicle crash or even an emergency maneuver or stop.

23. **Addendum A Fixed Route Accessible Service Guidelines. 1986.**  
**Ref ID #TP1**

Notes: Included in this paper are guidelines concerning eligibility, attendants, fare structure, lift procedures and operation, and boarding and deboarding instructions.

24. **White KP Jr, Gabler HC III, Pilkey WD, Hollowell WT. Minimizing Injuries in Frontal Collisions Using the SSOM Optimization Technique. In: Morton J, ed. Structural Impact and Crashworthiness. London and New York:Elsevier Applied Science Publishers. 1984:757-770.**  
**Ref ID #TP20**

Notes: An application of the SSOM optimization technique to determine the values of preselected vehicle design variables which minimize injuries in frontal collisions is described. The vehicle is a 3000lb automobile equipped with 3-point belts operating in the current U.S. accident environment. Results of the study suggest that when crashworthiness is defined in terms of injuries to occupants of both the striking vehicle and the vehicle struck, a progressive front-end collapse structure combined with stiffer belts is preferred.

## UNPUBLISHED REPORTS

25. **Edwards A, Hunter-Zaworski KM. Handicapped Accessible Public Transportation: Wheelchair/Scooter Lifts and Restraint Devices. 1991; Masters Thesis, Civil Eng. Dept. OSU.**  
**Ref ID #RP3**

Keywords: handicapped, PUBLIC TRANSPORTATION, WHEELCHAIR, RESTRAINT DEVICE, Lane Transit District, scooter

Notes: Many of the problems and concerns expressed during a survey of fixed route transit agencies and paratransit agencies dealt with the inability to secure all types of mobility aid devices. To meet the needs of the industry, studies need to be completed looking at the existing securement devices and modifications towards making them "universal". One of the most important issues of transportation of the handicapped is proper and appropriate securement while in motion. While several agencies responding to the survey had modified their securement/restraint devices by adding more belts and straps to try to insure proper and appropriate securement, two agencies have developed complete methods of securement. The agencies developing securement/restraint devices are Metropolitan Transit Commission of Minneapolis, Minnesota and Lane Transit District of Eugene, Oregon. It is assumed these modifications have not been scientifically tested. It is clear a "universal" restraint/securement device is needed.

26. **Wheelchair Lift Maintenance Cost. 1990.**  
**Ref ID #TP2**

Notes: This lists lift maintenance costs, combined fleet maintenance cost, lift-related parts inventory costs, number of road calls due to lift problems, and totals of each.

27. **McCown DrRB. Wheelchair Securement.** 1991; (UnPub).  
**Ref ID #PR5**  
Keywords: WHEELCHAIR, securement  
Notes: This is a series of hardcopy overheads concerning the different types of wheelchairs; what they are, what their uses are, and how they are similar.
28. **Accessibility Policy: Safety Rules and Procedures Regarding the Securement of Wheelchair/Scooter Onboard Buses.** 1989; (UnPub).  
**Ref ID #PR6**  
Keywords: WHEELCHAIR, scooter, securement  
Notes: Material from TRI-MET meeting in Portland, Oregon, April 10, 1991. The rules and procedures are actually dated 1989. Also included in this packet is a line count. There is an accessible service history attached at the end of the packet. It lists ridership for MAX and bus during 1989 and 1990 and explains when accessible route service began, and where they plan to be in July of 1991. Also listed is the number of buses, year purchased, and the model.
29. **Wheelchair/Scooter Securement: Who is Doing What.** 1991.  
**Ref ID #PR3**  
Notes: This is a two page listing of organizations working on standards and who is doing the work and what the work is.
30. **Paratransit Agencies.** 1991; (UnPub).  
**Ref ID #RP21**  
Notes: This is a listing of Paratransit Agencies. Information included in individual listings consists of contact name and title, agency, address, phone and FAX numbers, modes of transportation, agency fleet size, average lift cycles, annual passenger miles, vehicle(s) type and model, number of vehicles, number of vehicles with lifts, lift type and model, age of lift, securement device name, number of devices per vehicle, number of devices in system, description of device, description of personal restrain system, limitations of device, and year device installed.
31. **Fixed Route Transit Agencies.** 1991; (UnPub).  
**Ref ID #RP20**  
Notes: This is a listing of transit agencies. Information included in each individual listing consists of: contact name and title, agency, address, phone number & FAX number, modes of transportation, agency fleet size, average lift cycles, annual passenger miles, vehicle(s) names, number of each vehicle, lift number and type, age of lift, securement device(s) name, number of devices per vehicle, number of devices in system, year device installed, description of device, time to secure device, limitations of device, and whether or not the device is independent.
32. **McCown DrRD. Wheelchair Securement.** 1991; (UnPub).  
**Ref ID #RP25**  
Notes: This is a packet containing copies of overheads designed for presentation, sent to David Ullman from Dr. Robert B. McCown. The subject of the overheads is "Wheelchair Securement."
33. **Metropolitan Transit Commission.** 1991; (UnPub).  
**Ref ID #RP19**  
Keywords: wheelchair securement, MTC II  
Notes: This is a communication from Metropolitan Transit Commission, specifically Thomas N. Vida, to Dr. Kate Hunter-Zaworski. It contains diagrams that visually portray the MTC II wheelchair securement system.

34. Hunter-Zaworski KM. **Second Quarter Report Universal Securement/Restraint System for Mobility Aids on Public Transportation.** 1991; (UnPub).  
Ref ID #RP18

Keywords: wheelchair restraint

Notes: Summary of Progress to Date: The first third of the project activities are now complete. The schedule of project tasks is attached as Appendix A. On the schedule, the time lines reflect both the proposed and actual durations of the tasks. It can be seen that tasks 1 to 8 are complete. Tasks 1 to 5, which included the literature review, survey and questionnaire analysis indicated the current state of the art in securement and restraint technology on both fixed route and paratransit vehicles. Concurrent with the determination of the state of the art, was the development of the design matrix for the development of the design specifications and guidelines. A systematic design methodology was applied for the development of the matrix. Illustrations of the matrix and its function in the design process are attached to this quarterly report. Part of the development of the matrix included "benchmarking" existing technology. Studies of the current technology that is either in common use or has been extensively field tested was used for the development of the bench marks for the design. Benchmarking is important for determining a baseline from which to compare the new design.

Another important aspect of the systematic design process is a rigorous approach to understanding all facets of the design problem. As part of the process the research team has explored many other sources of information. These sources include: mobility-aid manufacturers and distributors, securement system manufacturers and suppliers, state and federal government officials in both the U.S. and Canada transit system operators across North America, members of the various teams involved in the development of wheelchair standards and securement standards, mobility-aid users who regularly use transit, and bus seating manufacturers and bus manufacturers. All these individuals have made a significant contribution to the understanding of the problem, as well as the development and quantification of the matrix. In preparation for the project, many of the standard components found in commonly used securement/restraint systems were tested for fatigue failure.

## STANDARDS

35. Society of Automotive Engineers (SAE). **Brake System Performance Requirements--Truck, Bus, and Combination of Vehicles--SAE J992 MAR85.** 1985.  
Ref ID #RP8

Notes: The performance requirements in this SAE Recommended Practice represents the accumulation of the best information available from investigation of the brake system performance of new motor vehicles designed for roadway use.

36. Hunter-Zaworski KM. **The Status of Wheelchair Occupant Restraint Standards for Motor Vehicles: Transportable Devices.** Transportation Research Board. 1989.  
Ref ID #ST4

Keywords: WHEELCHAIR, OCCUPANT, RESTRAINT, VEHICLE, ISO, AUSTRALIAN STANDARD, transportability

Notes: Internationally and nationally, there has been significant progress in the development of international standards for wheelchair occupants in motor vehicles during 1988 and 1989. Many of the European countries have standards or guidelines that reflect a generalized approach to the problem by specifying the wheelchair loading and test accelerations. In North America, as well as the International Standards Organizations (ISO) have taken the approach of modifying the Australian Standard by broadening the standards to include personal licensed vehicles. The North American approach is sensitive to the use of the private automobile for personal transportation as well the diversity of the wheelchair market.

In North America, travelling disadvantaged consumers and transportation providers have been struggling for safe accessible public transportation, but their efforts have been thwarted by liability insurance problems and a lack of cost effective and implementable technical solutions. As a result of the standards development process and difficulty in procuring liability insurance, transportability of the mobility devices

has become an issue rather than wheelchair occupant protection. The result of the transportation issue has been more limited transportation options for the transportation disadvantaged. Support and further research are required to solve the technical problem of providing safe and practical wheelchair occupant restraints for motor vehicles.

37. **SAE. Collision Deformation Classification--SAE J224 MAR80. 1980.**  
**Ref ID #RP7**

Notes: The purpose and scope of this SAE Recommended Practice is to provide a basis for classification of the extent of vehicle deformation caused by vehicle accidents on the highway. It is necessary to classify collision contact deformation (as opposed to induced deformation) so that the accident deformation may be segregated into rather narrow limits. Studies of collision deformation can then be performed on one or many data banks with assurance that the data under study are of essentially the same type. The seven-character code is also an expression useful to persons engaged in automobile safety, to describe appropriately a field-damaged vehicle with conciseness in their oral and written communications. Although this classification system consists of seven characters, three numeric, and four alphameric, arranged in a specific order. The characters describe the deformation detail concerning the direction, location, size of the area, and extent which, combined together, form a descriptive composite of the vehicle damage.

38. **SAE. Belt Hardware Performance Requirements--SAE J141 FEB73. 1973.**  
**Ref ID #RP29**

Notes: This SAE Recommended Practice describes performance requirements for hardware used in Type 1 and Type 2 motor vehicle seat belt restraints when tested in accordance with the test procedures specified in J140.

39. **SAE. Vehicle Acceleration Measurement--SAE J1491 JUN85. 1985.**  
**Ref ID #RP9**

Notes: This SAE Recommended Practice provides a standardized means of measuring acceleration performance of passenger cars and light duty trucks. Scope--To define significant driving situations involving acceleration, establish meaningful measures of such accelerations, and develop test procedures that will measure a vehicle's maximum performance capabilities during those driving situations.

40. **Society for the Advancement of Rehabilitation Technology (RESNA). Proposed American National Standard WHEELCHAIRS: DETERMINATION OF EFFECTIVENESS OF BRAKES. 1987.**  
**Ref ID #ST17**

41. **RESNA. Proposed American National Standard WHEELCHAIRS: DETERMINATION OF DYNAMIC STABILITY OF ELECTRIC WHEELCHAIRS. 1987.**  
**Ref ID #ST16**

42. **RESNA. Proposed American National Standard WHEELCHAIRS: DETERMINATION OF ENERGY CONSUMPTION OF ELECTRIC WHEELCHAIRS. 1987.**  
**Ref ID #ST18**

43. **Specially Equipped School Bus Standards. 1991.**  
**Ref ID #ST2**

Keywords: power lift, VEHICLE

Notes: The specifications in this section are intended to be supplementary to specifications in the chassis and body sections. In general, specially equipped buses should meet all the requirements of those preceding sections plus those listed in this section. Since it is recognized by the entire industry that the field of special transportation is characterized by varied needs for individual cases and by a rapidly emerging technology for meeting these needs, a flexible, common-sense approach to the adoption and enforcement of specifications for these vehicles is prudent. The following standards address modifications as they pertain to school buses that, with standard seating arrangement prior to modification, would accommodate more

that 10 persons. If by addition of a power lift, mobile seating device positions or other modifications, the capacity is reduced such that the vehicles become MPV's, the intent of these standards is to have these vehicles be required to meet the same standards they would have had to meet prior to such modifications, and such MPV's are included in all references to school buses and requirements for school buses which follow.

44. **RESNA. Proposed American National Standard WHEELCHAIRS: DETERMINATION OF OVERALL DIMENSIONS, MASS, AND TURNING SPACE. 1987.**  
**Ref ID #ST19**

45. **Australian Standard ME/48/3/90-1 Wheelchair Occupant Restraint Assemblies for Motor Vehicles. 1990.**  
**Ref ID #ST1**

Keywords: AUSTRALIAN STANDARD, WHEELCHAIR, OCCUPANT, RESTRAINT, VEHICLE

Notes: This Standard was prepared by the Standards Australia Committee on Restraint Systems in Vehicles, to supersede AS 2942-1987. The decision to prepare the original Standard was made following requests from the National committee on Biomedical Engineering of the Institution of Engineers, Australia and the Vehicle Standards Advisory committee. The mechanical Standards board of Standards Australia established a subcommittee of experts in the field of transportation of disabled in wheelchairs to review and guide the development of the Standard. A major contributor in the preparation of the Standard was Dr. W. Fisher who at the time was developing transportation procedures and techniques for the Regency Park Centre for Young Disabled, a division of the Crippled Children's Association of South Australia Incorporated, with technical support coming from Rainsfords Metal Products Pty Ltd. The rapid acceptance of the first edition of the Standard, and its adoption in legislation in most Australian States, has resulted in a need to provide Standards Mark Certification for wheelchair occupant restraint assembly kits available for purchase, and the removal of some installation requirements previously specified that are now subject to vehicle registration authorities' specification and approval. This edition reflects these changes.

46. **RESNA. FOREWORD. 1987.**  
**Ref ID #ST13**

Notes: (This foreword is not a part of American National Standards for Wheelchairs.) The initial work on wheelchair standards began on November 5-6, 1981, at Zeist, Holland, at the first meeting of ISO/TC 173/SCI. The United States delegation, headed by Mr. K. Rodawa, was organized by the Health Industries Manufacturing Association (HIMA) in response to a request by ANSI. In 1983, by mutual agreement the administrative responsibility was transferred to the Rehabilitation Engineering Society of North America (RESNA) for the purpose of developing American National Standards as well as representing the United States at ISO/TC 173/SCI. The work has been supported by a contract from the Veterans Administration, by the Paralyzed Veterans of America, by contributions from industry, and technical support from the Food and Drug Administration and other agencies.

The American National Standards are, with a few exceptions, essentially the same as the ISO standards, and each standard refers to the corresponding ISO document. In addition to the members and associate members listed below, the draft RESNA standards have been mailed to 160 interested persons whose comments have been considered in the final drafts. These national standards are in a series of standards for wheelchairs comprising terms and definitions, type classification, technical specifications, and test methods.

47. **RESNA. Proposed American National Standard WHEELCHAIRS: DETERMINATION OF STATIC STABILITY. 1987.**  
**Ref ID #ST15**

48. **RESNA. Proposed American National Standard WHEELCHAIRS: NOMENCLATURE, TERMS, AND DEFINITIONS. 1987.**  
**Ref ID #ST14**

49. **Beusenberg IrM, Goudswaard IrP. Several Comments and Recommendations of the Dutch Delegation of ISO/TC173/WG6: "Wheelchair and Occupant Restraint Systems" to this Working Group. 1991.**  
**Ref ID #PR1**

**Keywords:** occupant restraint system, WHEELCHAIR

**Notes:** A lot of different types of transportation safety devices can be put into the objective of standardization within ISO/TC173/WG6 (further referred to as WG6). This document, however, only discusses general principles of standardization on Wheelchair Occupant Restraint Systems (WORS) for personal and public transport, as is the subject of part I of the standard to be developed by WG6 (see minutes of the 4th meeting).

The first objective of a WORS should be the protection of a wheelchair occupant during transport, against impact load resulting from a collision or other sudden change of vehicle motion. The TNP Road-Vehicles Research Institute has conducted several tests with wheelchair occupant restraint systems and performed studies in the field of standardization and development of these systems. The knowledge from these research projects and the objective of increasing wheelchair occupant safety during transport, has lead to the formulation of several comments and recommendations addressed to WG6. The department of Injury Prevention of the TNO Road-Vehicles Research Institute is planning to continue its research in the field of disabled transportation safety. We strongly hope that WG6 will take this discussion document into consideration in the development of a standard on Wheelchair Occupant Restraint Systems.

50. **Doolittle P. Report on ISO TC173/SC1/WG6 Meeting in Metz. 1990.**  
**Ref ID #PR2**

**Keywords:** ISO, restraint system, CSA

**Notes:** The ISO wheelchair restraint working group, WG6, met in Metz, France, May 10 and 11 following a series of meetings of WG1 and WG5 earlier in the week. WG 6 Chair Franz De Moel announced that the new ISO number for the restraint standard is ISO 10542, which may consist of several parts.

51. **SAE. Seat Belt Hardware Test Procedure--SAE J140a Seat Belt Hardware Performance Requirements--SAE J141. 1973.**  
**Ref ID #RP24**

**Keywords:** RESTRAINT

**Notes:** SAE--J140a This SAE Recommended Practice describes test procedures for evaluating hardware used in Type 1 and Type 2 motor vehicle seat belt assemblies. The hardware test procedures covered in this report are intended to supersede those now reported in SAE J4c. Related hardware performance requirements are covered in SAE J141. Test procedures and performance requirements for seat belt retractors will likewise be covered in separate SAE Recommended Practices to be issued later. SAE J141--This SAE Recommended Practice describes performance requirements for hardware used in Type 1 and Type 2 motor vehicle seat belt assemblies when tested in accordance with the test procedures specified in SAE J140. Also included is SAE J117--Dynamic test procedure, SAE J339--Seat belt assembly webbing abrasion test procedure, and SAE J114--Seat belt assembly webbing abrasion performance requirements.

52. **National Standard for School Bus Operation: Special Education. 1991.**  
**Ref ID #ST3**

**Keywords:** handicapped, pupil transportation

**Notes:** The purpose of this section of the operations guidelines is to recommend standard policies, procedures and guidelines for persons entrusted with the responsibility of managing transportation for special needs students. The term "SPECIAL EDUCATION" means specially designed instruction to meet the unique needs of a handicapped student. Transportation is one of the "related services" required when necessary to provide such instruction. This section reviews the current laws governing special transportation

related to the individualized education program process, recommended staff training, and policy development. The guidelines, policies, and procedures recommended, though general in nature, do contain adequate information to guide those persons responsible for pupil transportation services for special needs students.

**53. Guideline Specifications for Wheelchair and Mobility Aid Securement Devices.** Battelle Memorial Institute. 1991.

**Ref ID #ST31**

**Keywords:** mobility aid, securement device, WHEELCHAIR

**Notes:** These guideline specifications are for use by accessible vehicle purchasers in preparing specifications for securement systems. These guidelines are an updating of UMTA's "Guideline Specifications for Wheelchair Securement Devices" prepared in 1986, with major changes that are required in order to be in agreement with 36 CFR, Part 1192. Part 1192 sets forth minimum guidelines and requirements for accessible design (MGRAD) for the disabled which were prepared by the Architectural and Transportation Barriers compliance Board (ATBCB) and is being implemented in response to the Americans with Disabilities Act of 1990. Some of the guidelines are direct quotations from Part 1192. Others of the guidelines are similar in meaning to paragraphs in Part 1192 with minor changes to improve the clarity of securement specifications. All Technical Requirements based on Part 1192 use the word "shall" to denote that the specific requirement is established by the regulation. The word "should" is used in the other requirements to denote that they are advisory. The vehicle purchaser who uses these guideline specifications may choose to replace would with shall on any of these requirements that are deemed important by those preparing a bid package.

**54. Wheelchair Tie-Down and Occupant Restraint Systems for Motor Vehicles.** 1990.

**Ref ID #ST7**

**Keywords:** WHEELCHAIR, occupant restraint system, mobility aid, ISO

**Notes:** This is an update of the draft document WG-6-48 A. That document was submitted to the ISP/TC-173/SC-1/WG-6 at the November 1, 1990, meeting in Washington. The changes made in this updated document were made by an editorial working group of the US/SAE Task Group working in Detroit, Michigan on April 27, 1990. This standard is set forth with the recognition that there are many makes, models, and styles of wheelchairs in use and that few wheelchairs have been designed for the purpose of serving as motor vehicle seats. Thus, most wheelchairs have shortcomings from both functional and safety perspectives when used for seating in a motor vehicle. Wheelchair users are therefore encouraged to transfer to the original equipment manufacturers (OEM) vehicle seats whenever this is feasible and to use OEM vehicle restraint systems.

It is also recognized that transfer out of the wheelchair when traveling in a motor vehicle is not always feasible, and that the number of persons seated in wheelchairs while traveling in motor vehicles is increasing as this population seeks to live more mobile and independent lives. It is therefore not a reasonable option to ignore or discourage the use of wheelchairs and other mobility aids in motor vehicles. This being the case, this ISO standard has been developed to establish test procedures, performance criteria, and crashworthiness design requirements that will provide the wheelchair-seated occupant a comparable level of crashworthiness protection to that offered the able-bodied population through existing motor vehicle safety standards. In so doing, this standard is applicable to wheelchair tie-down and occupant restraint systems (WTORS) that do not involve any wheelchair modifications, designs in which parts of the WTORS are bolted or otherwise rigidly fixed to the wheelchair, and designs which require wheelchair frames manufactured with integral restraint components.

Throughout this standard, the term "wheelchair tie-down and occupant restraint system" (WTORS) will refer to equipment, procedures, and devices intended to restrain both the wheelchair and the occupant in a vehicle impact. Equipment used to provide restraint of the wheelchair will be referred to as "wheelchair tie-down" equipment, while the equipment used to restrain the occupant will be referred to as "occupant restraint" equipment.

In setting forth this standard, it is recognized that effective restraint for people seated in wheelchairs requires that both the wheelchair and the occupant be restrained with respect to the transport vehicle. The



wheelchair contributes to restraint of the occupant by virtue of its structural design and strength with regard to the potential for effective securement, and through support of the occupant through the seat cushion, backrest, and armrests. The complete restraint system therefore involves the wheelchair, the tie-downs for the wheelchair, and the restraints for the occupant. This standard addresses only the wheelchair tie-down and occupant restraint systems. Design requirements, test procedures and performance requirements for the wheelchairs and other mobility aids with regard to safe motor vehicle seating is addressed in a separate and similar ISP standard No.

The design requirements, test procedures, and performance criteria outlined in this document take into account current knowledge, technology, and practices in the areas of impact biomechanics, dynamic testing, test instrumentation, crash dummy design, and injury criteria. It is expected that this standard will serve to: a) specify and standardize test methodology so that the results from various facilities can be compared, and b) guide developers, manufacturers, users, installers, and third-party purchasers of WTORS in the design, purchase, and implementation of more effective systems for use in motor vehicle transportation.

55. **Architectural and Transportation Barriers Compliance Board. 36 CFR Part 1191 March 29, 1991 Americans with Disabilities Act (ADA) Accessibility Guidelines for Buildings and Facilities; Supplemental Notice; Proposed Rules Part III. Federal Register. 1991.**

**Ref ID #ST28**

**Keywords: ADA, ACCESSIBILITY, DISABLED, WHEELCHAIR**

**Notes: On January 22, 1991, the Architectural and Transportation Barriers Compliance board published proposed guidelines to provide guidance to the Department of Justice on establishing accessibility standards for new construction and alterations in places of public accommodation and commercial facilities, as required by title III of the Americans with Disabilities Act (ADA) of 1990. The proposed guidelines reserved a section for additional requirements for transportation facilities. This supplemental notice of proposed rulemaking (SNPRM) proposes additional requirements for transportation facilities and will ensure that such facilities are readily accessible to and usable by individuals with disabilities in terms of architecture and design, transportation, and communication. The SNPRM also proposes to make the guidelines applicable to publicly operated transportation facilities covered by title II of the ADA in order to provide guidance to the Department of Transportation on establishing accessibility standards for those facilities.**

56. **Standards Australia Wheelchair Occupant Restraint Assemblies for Motor Vehicles. 1990.**

**Ref ID #ST6**

**Notes: Wheelchair occupant restraint assemblies complying with this Standard should give protection in most accidents if they are properly installed and worn correctly. In general, wheelchairs are not well suited to the requirements of normal passenger seats and seat belts. Wheelchair occupants should transfer to passenger seats in vehicles and use the seat belt provided whenever that is practicable and the unoccupied wheelchairs should be restrained. Effective restraint for people occupying wheelchairs requires the wheelchair to be restrained to the transport vehicle, and the occupant to be restrained either directly to the vehicle or to parts which are themselves attached to the vehicle. The wheelchair contributes to restraint of the occupant by virtue of the support of the wheelchair seat, back rest, and arm rests. The complete restraint system includes the wheelchair itself and restraints for the occupant and for the wheelchair.**

**There are currently no recognized Standards covering wheelchairs suitable for vehicle seating, and, even if such Standards could be rapidly implemented, the problems of vehicular transport for people occupying non-complying wheelchairs would remain for many years. However, provided that suitable restraints are fitted, tests have shown that some types of wheelchairs can survive a severe impact without fractures of the frame. This Standard specifies restraints for wheelchairs and their occupants and does not specify strength requirements for wheelchair structures or for vehicle structures used to anchor wheelchair occupant restraint assemblies. Rather, the manufacturer of wheelchair occupant restraint assemblies is required to provide details of strength requirements at the mounting points of a restraint assembly. Vehicle regulatory authorities require approval of restraint installations, and should be consulted for advice on reinforcement of vehicle structures at mounting points. To allow for various applications, the Standard allows for designs that do not require any wheelchair modifications, those in which parts of the restraint**

assembly are installed onto the wheelchair, wheelchairs that incorporate a child safety seat complying with AS 1754, and wheelchair frames manufactured with integral restraint components.

57. **RESNA. Proposed American National Standard APPENDIX 1. 1987.**  
**Ref ID #ST22**

58. **SAE. SAE Committee Comments on Australian Standard, AS 2942-1987. 1989.**  
**Ref ID #ST25**

Keywords: wheelchair occupant restraint, ISO

Notes: The Restraint System Working Group of the Society of Automotive Engineers (SAE) Adaptive Devices Standards Committee reviewed the Australian Standard Wheelchair Occupant Restraint Assemblies for Motor Vehicles on January 23, 1989. The following comments are offered to the ISO committee developing an international standard for wheelchair occupant restraint systems.

59. **Motor Vehicle Safety Standard No. 209 Seat Belt Assemblies. 1991.**  
**Ref ID #ST26**

Notes: This standard specifies requirements for seat belt assemblies. This standard applies to seat belt assemblies for use in passenger cars, multipurpose passenger vehicles, trucks, and buses.

60. **RESNA. Proposed American National Standard WHEELCHAIRS: DETERMINATION OF SEATING DIMENSION. 1987.**  
**Ref ID #ST20**

61. **RESNA. Proposed American National Standard WHEELCHAIRS: FATIGUE, STATIC AND IMPACT STRENGTH TESTS FOR MANUAL WHEELCHAIRS(1). 1987.**  
**Ref ID #ST21**

62. **Appendix H: Minnesota Securement/Restraint Laws Chapter 7450, Department of Public Safety Patrol Division, Wheelchair Safety Devices. 1991.**  
**Ref ID #ST27**

Keywords: WHEELCHAIR, securement, standard

63. **ASTM A 414/A 414M, A 505, A 500. ASTM. 1988.**  
**Ref ID #ST33**

64. **Association's Committee on Restraint Systems in Vehicles. Wheelchair Occupant Restraint Assemblies for Motor Vehicles (AS 2942-1987). Australian Standard. 1987.**  
**Ref ID #ST5**

Keywords: AUSTRALIAN STANDARD, WHEELCHAIR, OCCUPANT, VEHICLE, restraint system

Notes: The decision to prepare the Standard was made following requests from the National Committee on Biomedical Engineering of the Institution of Engineers, Australia and the Vehicle Standards Advisory committee. The Mechanical Standards Board of the SAA established a subcommittee of experts in the field of transportation of disabled in wheelchairs to review and guide the development of the Standard. A major contributor in the preparation of the Standard was Dr. W. Fisher of the Regency Park Centre for Young Disabled, a division of the Crippled Children's Association of South Australia Incorporated, with technical support coming from Rainsfords Metal Products Pty Ltd.

65. **Mazankowski D. Motor Vehicle Safety Act Motor Vehicle Test Centre Fees Order. Canada Gazette Part II. 1986; 120, No.4:698-704.**  
**Ref ID #RP22**

**66. Standards for Transportation Systems for the Physically Disabled.** Canadian Standards. 1991.  
**Ref ID #ST8**

**Keywords:** DISABLED, accessible transportation

**Notes:** Increasingly, Canadians are recognizing the need and the right of persons with disabilities to be mobile. Although much activity tends to focus on meeting the increasing demand for wheelchair-accessible transportation, the quality of the equipment used to transport the disabled is also a matter of concern. As a result of the absence or inadequacy of technical design or engineering standards for this equipment, the Canadian Standards Association is about to prepare the following three Standards: (1) National Standard of Canada for Transportable Mobility Aids; (2) National Standard of Canada for Mobility Aid Securement Systems; and (3) revision of CSA National Standard of Canada CAN3-D409-M84 Motor Vehicles for the Transportation of Physically Disabled Persons. Following their completion, these Standards will provide the basis for CSA National Certification Programs. The implementation of these Programs will assure product purchasers and regulatory authorities that the product in question meets the manufacturer's stated claims on a continuing basis.

**67. Transportable Mobility Aids for Occupancy in Moving Vehicles.** Canadian Standards Association. 1990; 1-11.

**Ref ID #ST12**

**Keywords:** mobility aid, scooter, WHEELCHAIR

**Notes:** Second Draft This Standard applies to mobility aids for persons having disabilities, including conventional and powered wheelchairs, and scooters. It is intended that this Standard be applied to mobility aids to determine their suitability for occupancy in a moving motor vehicle with the exception of vehicles intended for personal passenger use. Although the occupants of wheelchairs and scooters may be medically fragile, the level of protection to this Standard is intended to be equivalent to that provided to a medically fragile occupant of any vehicle designated seating position that complies with the Canada Motor Vehicle Safety Regulations.

At the time of preparation of this Standard, scooters and electric wheelchairs occupy distinctively different points in the spectrum of powered aids for personal mobility. As scooter and wheelchair configurations come to resemble each other more closely and their difference become less easy to define, a more generic approach to requirements for mobility aids, both manual and powered, may emerge and be accompanied by a consolidation of wheelchair and scooter requirements in a general standard. In the short term, this Standard is intended to define conventional wheelchairs, and powered wheelchairs and scooters with respect to safety considerations, including crashworthiness, as they exist at the date of publication.

By safety is meant the safe conveyance of all persons inside the vehicle; crashworthiness refers to frontal impact of a forward facing mobility aid. Personal mobility vehicles, adaptations of standard vehicles for disabled drivers, and mobility aids for disabled drivers while driving an adapted motor vehicle, are beyond the scope of this Standard. This Standard was prepared by the Subcommittee on Transportable Mobility Aids under the jurisdiction of the Technical Committee on Technology for the Disabled, and was formally approved by the Technical Committee and the Standards Steering Committee on Health Care Technology. It has been approved as a National Standard of Canada by the Standards Council of Canada.

**68. Report of the Ad Hoc Group on Wheelchair Securement.** Canadian Standards Association. 1990.

**Ref ID #TP4**

**Keywords:** wheelchair securement system

**Notes:** 1. Report on Crash testing conducted by DB Transit and UBC. 2. CSA projects to develop standards for Transportable Mobility Aids, Wheelchair Securement Systems and Vehicles for the Transportation of Physically Disabled Persons. 3. Agree that frontal impacts be given priority. 4. Support the notion of virtual or surrogate wheelchair test frames and securement systems.

69. **Mobility Aid Securement and Occupant Restraint (MOSAR) Systems for Motor Vehicles Lifestyles and the Environment.** Canadian Standards Association. 1990; 1-36.

Ref ID #ST11

Keywords: occupant restraint system, mobility aid

Notes: Second Draft In general, mobility aids (both wheelchairs and scooters) are not well suited to the requirements of vehicular seating, and the safety of passengers is best assured by the use of original equipment vehicle seats and restraint systems consisting of pelvic and upper torso restraints. Mobility aid occupants should transfer to passenger seats in vehicles and use the seat belt provided whenever that is practicable, and the unoccupied mobility aid should be secured.

Effective protection for persons occupying mobility aids requires that movement of both the mobility aid and the occupant be controlled with respect to the transport vehicle. The mobility aid contributes to restraint of the occupant by virtue of the support of the mobility aid seat, back rest, and arm rests. The complete protection system includes the mobility aid itself, securement components for the mobility aid, and restraints for the occupant. There are currently no recognized standards covering mobility aids suitable for vehicle seating, and even if such standards could be rapidly implemented the problems would remain for many years. However, tests have shown that suitable restraints will greatly reduce the likelihood of an occupant suffering a serious injury in a collision for many types and styles of mobility aids.

This Standard applies to mobility aid securement and occupant restraint systems, including designs that do not require any mobility aid modifications, designs in which parts of the securement and/or restraint components. Mobility aid securement and occupant restraint systems which comply with the Standard should reduce the risk of serious injury in most accidents if they are properly installed and correctly worn.

70. **Biokinetics and Associates Ltd. Development of a Dynamic Test Procedure for Transportable Mobility Aids and Securement Devices.** Canadian Standards Association. 1991; 4.

Ref ID #PP7

Notes: This volume describes the test procedure used to verify the proposed test methodology. The practicability of this methodology was tested by sled testing a variety of mobility aids including the surrogate mobility aid (SMA). At the same time, a variety of mobility aid securement and occupant restraint (MASOR) systems were also tested. This testing allowed the adequacy of the proposed performance requirements to be reviewed in using the current best practice in the industry. A complete set of test results is included in an Appendix.

71. **Schneider LW. Rationale, Historical Synopsis of the Literature, and Bibliography.** Canadian Standards Association. 1991; Vol. 2.

Ref ID #PP5

Notes: This report is divided into four sections. Section 1 is the introduction, Section 2 provides a discussion of the rationale upon which some of the key elements of the recommended test procedures and performance requirements are based. Section 3 provides an historical review and summary of many of the key publications and reports dealing with the subjects of mobility-aid securement and occupant restraint, with particular emphasis on procedures and performance requirements used in testing of mobility aids and MASOR systems. Finally, Section 4 contains a comprehensive bibliography of publications dealing with the issues of occupant restraint for wheelchair-seated travellers.

72. **Z604: Transportable Mobility Aids for Occupancy in Moving Vehicles - Third Draft. Z605: Mobility Aid Securement and Occupant Restraint (MASOR) Systems for Motor Vehicles - Third Draft.** Canadian Standards Association. 1991.

Ref ID #ST32

Keywords: mobility aid, RESTRAINT DEVICE, WHEELCHAIR

Notes: Third Draft In general, mobility aids i.e. wheelchairs, scooters, are not well suited to the requirements of vehicle seating, and the safety of passengers is best assured by the use of original equipment vehicle seats and restraint systems consisting of pelvic and upper torso restraints. Mobility aid occupants should transfer to passenger seats in vehicles and use the occupant restraint provided whenever that is practicable, and the unoccupied mobility aid be secured.

This Standard specifies requirements for mobility aids that are intended to be carried, both occupied and unoccupied, in vehicles equipped for this purpose. The requirements for the vehicles themselves are published in CSA Standard D409. The requirements for the securement system are published in CSA Standard Z605. Z605 This Standard specifies design requirements, test procedures, and performance requirements for mobility aid securement and occupant restraint (MASOR) systems used by passengers in public motor vehicle transportation.

73. **Biokinetics and Associates Ltd. Development of a Dynamic Test Procedure for Transportable Mobility Aids and Securement Devices, Summary and Recommendations.** Canadian Standards Association. 1991; Vol 1.  
**Ref ID #PP4**

Notes: The Canadian Standards Association is in the process of developing standards for mobility aids suitable for occupancy while being transported in vehicles, and the associated mobility aid securement and occupant restraint (MASOR) systems. This report outlines part of the this process, namely the development and verification of a dynamic impact sled test suitable for adoption as part of the draft CSA Standard Z604-Transportable Mobility Aids for Occupancy in Moving Vehicles and draft CSA Standard Z605-Mobility Aid Securement and occupant Restraint (MASOR) Systems for Motor Vehicles.

These standards are intended to form the basis for Testing and Certification Program to be offered to manufacturers, regulatory authorities, users, and other interested parties, and as a requirement for Proof of Compliance as part of specifications used by institutional or other purchasers. The test procedure is to ensure that mobility aid occupants and other occupants of the transporting vehicle are protected as far as is currently practicable against aid during a crash. The methodology chosen, because of the wide range of vehicle types currently in use, is to simulate a full scale frontal impact of the vehicle with a barrier by means of a sled impact in a laboratory situation.

The test procedure is similar for the two standards but with different aims. For CSA Standard Z605 for transportable mobility aids, the aim is to ensure that the wheel chair itself is of adequate design to withstand the test impact level without adding to the likelihood injury of either the wheelchair occupant or other vehicle occupants. For CSA Standard Z605 for the mobility aid securement an occupant restraint systems, the test requires the use of a surrogate mobility aid (SMA). Testing with this surrogate aims to set a minimum strength standard for securement and the occupant restraint systems. The test is applicable to all current configurations of manual wheelchairs, electronic wheelchairs, both 3 and 4 wheeled scooters and MASOR systems, with only minor variations. Pass/fail criteria are also set for both types of testing. Finally, this volume makes recommendations as to areas where future work is still necessary to complete the process of standards formation.

74. **TES Limited. Development of a Dynamic Test Procedure for Transportable Mobility Aids and Securement Devices.** Canadian Standards Association. 1991; Vol. 3.  
**Ref ID #PP6**

Notes: The Canadian Standards Association (CSA), as part of a program to develop standards governing Transportable Mobility Aids for Occupance in Moving Vehicles (CAN/CSA-Z604) and Mobility Aid Securement and Occupant Restraint (MASOR) Systems for Motor Vehicles (CAN/CSA-Z605), tasked Biokinetics and Associates Ltd. and through them T E S Limited, to develop a reusable test device which would represent a Transportable Mobility Aid in dynamic tests of MASORs as specified by the CSA standards.

This report describes the design and development of a Surrogate Mobility Aid (SMA) which is configured in accordance with the requirements of the two CSA draft standards.

The report is in two sections. Part I is the Design Specifications which was produced early in the program and approved by CSA. This document explains the rationale used in the detailed design of the SMA and includes design calculations and layout drawings of the device. It was previously published as T E S Report Number: C1768-1 in August 1991. Part 2 is a Design Review which describes changes made to the design as a result of factors which were noted during fabrication, as well as a change which addressed a minor problem that occurred during testing.

75. **49 CFR Part 27; 49 CFR part 37 Transportation for Individuals with Disabilities.** Department of Transportation. 1991; RIN 2105-AB53.

**Ref ID #ST29**

Keywords: DISABLED, WHEELCHAIR, paratransit, UMTA, ADA

Notes: The Department is proposing to amend its rule implementing the Americans with Disabilities Act (ADA) by adding sections concerning complementary paratransit, transportation facilities, and other matters not covered in its initial ADA final rule. This notice also responds to comments on that rule. It also proposes changes in the Department's rule implementing section 504 of the Rehabilitation Act of 1973 in light of the ADA rule.

76. Department of Transportation. **49 CFR Parts 27 and 37 Thursday, April 4, 1991 Transportation for Individuals with Disabilities; Proposed Rule Part II.** Federal Register. 1991.

**Ref ID #ST23**

Keywords: WHEELCHAIR, DISABLED, mobility aid, ACCESSIBILITY

Notes: The Department is proposing to amend its rule implementing the Americans with Disabilities Act (ADA) by adding sections concerning complementary paratransit, transportation facilities, and other matters not covered in its initial ADA final rule. This notice also responds to comments on that rule. It also proposes changes in the Department's rule implementing section 504 of the Rehabilitation Act of 1973 in light of the ADA rule.

77. Architectural and Transportation Barriers Compliance Board. **36 CFR Part 1192 Wednesday, March 20, 1991 Americans with Disabilities Act (ADA) Accessibility Guidelines for Transportation Vehicles; Proposed Rules.** Federal Register. 1991.

**Ref ID #ST24**

Keywords: ADA, ACCESSIBILITY

Notes: The Architectural and Transportation Barriers Compliance Board is issuing proposed guidelines to provide guidance to the Department of Transportation on establishing accessibility standards for transportation vehicles required to be accessible by the Americans with Disabilities Act (ADA) of 1990. The guidelines will ensure that transportation vehicles are readily accessible to and usable by individuals with disabilities in terms of architecture and design, transportation, and communication. The standards established by the Department of Transportation must be consistent with the guidelines.

## **CRASH TESTS**

78. Schneider LW. **An Overview of the University of Michigan Transportation Research Institute.** Ann Arbor, Michigan: The University of Michigan Transportation Research Institute. 1989.

**Ref ID #RP28**

Notes: Injury is the most under-recognized major public health problem facing the nation today, and motor vehicle injury is the largest single contributor to that problem. In the U.S., motor vehicle injury is the major cause of premature death because it so disproportionately strikes the younger half of the population. It is the leading cause of spinal cord injury and serious brain trauma, conditions that permanently cripple. While much has been accomplished, motor vehicle injury continues to maim and kill, especially our youth.

The University Transportation Research Institute (UMTRI) was established to address the problem of motor vehicle injury. UMTRI's multidisciplinary staff, in conjunction with the other considerable resources of the University of Michigan, can investigate questions of importance to the automotive industry and society in general.

79. Schneider LW. **Protection for the Severely Disabled - A New Challenge in Occupant Restraint.** Highway Safety Research Institute. 1981; 217-231 (Abstract).  
Ref ID #RP27

Keywords: wheelchair securement system, occupant restraint, driver restraint, passenger restraint

Notes: The numbers of severely disabled persons using public and private motor vehicle transportation to gain greater mobility and independence in their daily lives has risen substantially in recent years and is likely to continue to increase in the years ahead. While a significant effort has gone into finding new ways to make motor vehicle transportation accessible to these persons, relatively little concern appears to have been given to the safety of these passengers and drivers. Sled impact tests of typical wheelchair securement systems and occupant restraints for persons in wheelchairs reveal that most persons who must use their wheelchair for a vehicle seat are at high risk of injury in a vehicle accident. While the problem of occupant protection for this population is more complex than for the able-bodied, significant improvements in this situation could be made with good engineering design that adheres to basic crashworthiness principles and takes into account the magnitudes of forces generated in the crash environment.

80. Hobson DA. **Memo RE: Unconfirmed Minutes of Washington Meeting: Minutes from SAE Task Group Meeting on Wheelchair Restraints.** 1991; (UnPub).  
Ref ID #PR4

Keywords: SAE Task Group

Notes: Unconfirmed minutes of the meetings of the Wheelchair Restraints Task Group of the SAE Adaptive Devices Standards Committee January 15, 1990 at Washington, DC.

81. Brach RM. **Friction, Restitution, and Energy Loss in Planar Collisions.** Transactions of the ASME. 1984; 51:164-170.  
Ref ID #RP31

Notes: Both particle and rigid body planar collisions are covered in this paper. For particles, the classical equations for oblique impacts are derived using Newton's laws along with definitions of the coefficient of restitution and equivalent coefficient of friction. A general expression is obtained for the kinetic energy loss explicitly containing the two coefficients. This expression for energy loss as a function of the friction coefficient possesses a maximum. The value of the friction coefficient at the maximum is a limiting value which can be used to determine whether or not sliding exists at separation. The maximum energy loss is independent of the physical mechanism of generation of tangential forces (friction) and serves as an upper bound for two-particle collisions. It is shown that to properly formulate and solve the rigid body problem, a moment must be considered at the common "point" of impact. A moment coefficient of restitution must be defined. This leads to six linear algebraic equations from which the six final velocity components can be calculated. An analytical solution is obtained for the general rigid body problem. In a reduced form, it is used to solve the problem of a single rigid body impacting a rigid barrier. This solution is then applied to a classical textbook problem. As shown for particle impacts, the concepts of limiting friction coefficient and maximum energy loss apply to rigid body impacts.

82. Brach RM. **Momentum and Energy Analysis of Automobile Collisions.** In: Morton J, ed. **Structural Impact and Crashworthiness.** London and New York:Elsevier Applied Science Publishers. 1984:745-756.  
Ref ID #TP19

Notes: Principles of Impulse and Momentum frequently are used to study vehicle collisions. In some applications, angular rotations are neglected completely; in others, rotational velocity changes are treated approximately. In this paper, a moment over the crush surface is related to the angular velocity changes and its significance is evaluated with data from experimental collisions. Another feature of Impulse and Momentum models is the treatment of friction. It is shown that a maximum exists for the friction coefficient along with a corresponding maximum kinetic energy loss. This is discussed in general as well as how it leads to a simple equation for velocity change prediction.

83. **EZLock. UMTRI Sled Impact Test WK8602 Constantin Transit Vehicles "E.Z. Lock" Wheelchair Tie-Down.** 1986.  
**Ref ID #TP21**

Keywords: WHEELCHAIR

Notes: This report briefly describes the test conditions of sled impact test WK8602 conducted at the University of Michigan Transportation Research Institute (UMTRI). In this test, Constantin Transit Vehicles' "E.Z. Lock" wheelchair tie-down system was dynamically tested for a simulated vehicle crash pulse of 30 mph and 20 g's deceleration. This test is essentially a repeat of test WC8601. In that test, a lap belt that anchors to the tie-down hardware attached to the wheelchair was loosened since the manufacturer indicated that it was not intended for occupant restraint during a vehicle impact. In test WK8602, this chair-anchored lap belt was tightened to match the test setup conditions of previous tests of driver tie-down systems conducted for the Massachusetts Rehabilitation Commission (MRC)--tests WM8501 through WM8506. As in the MRC tests, a vehicle-anchored restraint system was included in all these tests (either a shoulder belt or three-point belt) to provide occupant restraint for the test dummy. In this test, Constantin Transit Vehicles provided a three-point vehicle belt for this purpose.

84. **Mani A, Krishnaswamy P. Advances in Crash Simulation Technology.** Automotive Engineering. 1991; Vol. 99, Number 2:20-23.

**Ref ID #RP32**

Notes: Automobile, mass transit vehicle, aircraft, and other industries are focusing more attention than ever before on reducing occupant injuries during crashes. New, more stringent, Federal Motor Vehicle Safety Standards (FMVSS) are expected soon, including side crash standards and basic standards for light trucks. As new design concepts in crash safety are developed, the need to determine their effectiveness quickly, accurately, and economically becomes greater. It takes several months and costs as much as a half million dollars to develop and dress up an automobile with the instrumentation required for a single crash test. Thus interest is increasing in computerized crash simulation technology, which allows an unlimited number of simulations to be run from a single model, with each simulation taking only a matter of hours.

85. **Barrier Crash Tests of 3-wheeled Scooters and Wheelchairs in Paratransit Vans.** BC Transit 1990; Victoria, B.C.

**Ref ID #TP10**

Keywords: scooter, WHEELCHAIR

Notes: Three different wheelchairs and thirteen scooters of seven different models were crash tested in seven paratransit vans and one full-size transit bus. The paratransit vans used a 100-tonne barrier target in six tests and the transit bus as a target vehicle in one test. All tests, including the van/bus crash, were head-on; observation was by accelerometer and high-speed video. Male 50th and 95th percentile dummies (165 lb and 215 lb respectively) were restrained by lap/diagonal assemblies with the exception of the dummy in the transit bus, which was restrained by a lap belt only. Scooters were tested with permutations of dummy and restraint/securement systems.

The first test produced a nominal 30 g at 25 mph, and all other tests produced a nominal 30 g at 20 mph. Spike g was in the 50 g range in each test. The paratransit vans were relatively stiff with very little crush evident; nominal g quoted is a subjective average with spike values discounted. Scooter deformation was sufficient to infer a possible direct cause of injury to their occupant; there was no threat to other passengers by missiles from the scooter breaking up because this did not occur. However, batteries broke loose and scooter/dummy excursion extended into adjoining passenger space. Scooter securement systems were of two types, continuous track and floor inserts, both providing 4-point securement; scooter placement was easier with the former. A supplementary fifth securement strap, used by one manufacturer in earlier sled tests at UMTRI, was employed in several runs to investigate any improvement. The large displacements of scooters resulted in part from relatively elastic securement straps. This will require investigation.

Occupant restraint systems were representative of current buckle and webbing stock. They were assembled from automotive components but were not labelled as certified for this type of service. Buckle failure in two tests made the upper torso belt securement at the buckle suspect in those hybrid assemblies. Two separation failures of upper torso anchor point from vehicle structure were experienced, one complete



and one partial. Scooter kinematics varied, markedly so in one test, and could not be described as controlled. However, there was no real evidence that the scooter securement system directed scooter g loads via the occupant into the occupant restraint system, except due to deformation of scooter structure. While scooters ended up bent or with minor breaks, the overall structural integrity of the scooter turned out to be better than expected; it is recognized that test conditions were near ideal, viz. new scooters, new securement, experts ensuring optimum securement, etc.

Anthropomorphic test device (ATD), i.e. dummy, performance varied from good to poor during the ridedown phase of the crash. This was directly related to the occupant restrain systems, with little influence from the scooter. Energy management in the total system, particularly in the rebound, must be improved for operation with safety.

**86. BC Transit Crash Tests of 3-Wheeled Scooters and Wheelchairs in Paratransit Vans. BC Transit 1990; Victoria, B.C.**

**Ref ID #TP5**

**Keywords:** paratransit, scooter, occupant restraint system

**Notes:** Three different wheelchairs and thirteen scooters of seven different models were crash tested in seven paratransit vans and one full-size transit bus. The paratransit vans used a 100 ton barrier target in six tests and the transit bus as a target vehicle in one test. All tests, including the van/bus crash, were head-on; observation was by accelerometer and high speed video. Male 50th and 95th percentile dummies (165 lb and 215 lb respectively) were restrained by lap/diagonal assemblies with the exception of the dummy in the transit bus, which was restrained by a lap belt only. Scooters were tested with permutations of dummy and restraint/securement systems.

The first test produced a nominal 25 g at 25 mph, and all other tests produced a nominal 20g at 20 mph. Spike g was in the 50 g range in each test. The paratransit vans were relatively stiff with very little crush evident; nominal g quoted is a subjective average with spike values discounted. Scooter deformation was sufficient to infer a possible direct cause of injury to their occupant; there was no threat to other passengers by missiles from the scooter breaking up because this did not occur. However, batteries broke loose and scooter/dummy excursion extended into adjoining passenger space. Scooter securement systems were of two types, continuous track and floor inserts, both providing 4-point securement; scooter placement was easier with the former. A supplementary fifth securement strap, used by one manufacturer in earlier sled tests at UNTRI, was employed in several runs to investigate any improvement. The large displacements of scooters resulted in part from relatively elastic securement straps. This will require investigation.

Occupant restraint systems were representative of current buckle and webbing stock. They were assembled from automotive components but were not labelled as certified for this type of service. Buckle failure in two tests made the upper torso belt securement at the buckle suspect in those hybrid assemblies. Two separation failures of upper torso anchor point from vehicle structure were experienced, one complete and one partial. Scooter kinematics varied, markedly so in one test, and could not be described as controlled. However, there was no real evidence that the scooter securement system directed scooter g loads via the occupant into occupant restraint system, except due to deformation of scooter structure. While scooters ended up bent or with minor breaks, the overall structural integrity of the scooter turned out to be better than expected; it is recognized that test conditions were near ideal, viz. new scooters, new securement, experts ensuring optimum securement, etc.

Anthropometric test device (ATD), i.e. dummy, performance varied from good to poor during the ride down phase for the crash. This was directly related to the occupant restraint systems, with little influence from the scooter. Energy management in the total system, particularly in the rebound, must be improved for operation with safety.

**87. Roy P. Summary of Impact Performance of Three Types of Standard Wheelchair. Middlesex Polytechnic. 1990.**

**Ref ID #TP3**

**Keywords:** WHEELCHAIR

**Notes:** This paper contains data from tests carried out on wheelchairs using the impact sled in the Road Safety Engineering Laboratory of the Middlesex Polytechnic, Hendon, London. The work was carried out

under contract to the Department of Health, in order to provide some data for the meeting of ISP/TC 173/SC 1/WG6 in Metz (May 1990). Ten impacts were carried out on four types of wheelchair.

88. Mercer W, Billing JR. **Assessment of a Transportable Mobility Aid in Severe Driving Conditions –An Exploratory Test.** Ministry of Transportation. 1991; CV-90-03.

**Ref ID #TP11**

Keywords: scooter

Notes: A severe driving test was conducted on a vehicle containing a transportable mobility aid (a scooter) with a male anthropomorphic dummy as a rider. A portion of the test was to see if the system behaved in accordance with CSA D409 Standard. The remaining portion of the test was to observe the behavior of the system under high dynamic vehicle induced loading. The test showed that the base of the scooter met the D409 standard. However, the displacement of the upper portions of the scooter, which are not specified in D409, exceeded the displacements of the base by a large margin. Under high dynamic loading, up to 0.8 g lateral acceleration, the scooter responded with high roll angles and large lateral swaying motions. It was found that these were very sensitive to the manner in which the scooter was secured, and the air pressure in the scooter tires. Loads measured in the restraint system indicated that the restraints were operating well under design limits. This test was done to provide insight to the Canadian Standards Association committee currently examining the D409 standard regarding securement of this type of mobility aid.

89. Schneider LW, Melvin JW. **Impact Sled Rest Evaluation of Restraint Systems Used in Transportation of Handicapped Children.** SAE Technical Paper Series. 1979.

**Ref ID #TP16**

Notes: A series of 16 sled impact tests was conducted at the Highway Safety Research Institute sled facility to evaluate the effectiveness of restraint devices and systems currently being used to transport school-bus and wheelchair-seated handicapped children. A sled impact pulse of 20 mph and 16 G's was used for all tests. Eight tests involved wheelchairs in forward-facing and side-facing orientations for head-on and 33-degree oblique impacts. Another eight tests involved forward-facing and side-facing orientations for head-on and 33-degree oblique impacts. Another eight tests involved forward-facing bus seats for head-on and 33-degree oblique impacts. The results generally point out the ineffectiveness of many currently used devices and systems for protecting the child in a bus collision. In six of the eight bus seat tests the dummy's head struck the back of the bus seat in front. This was primarily because of a lack of upper-torso restraint. A padded belt commonly used for restraining children in wheelchairs is also inadequate by itself and should only be used with additional thorax and pelvic restraint. The practice of placing wheelchairs in a side-facing orientation was found to be a poor one for the protection of the child.

90. **Documentation for Sled Test as Conducted at Transportation Research Center of Ohio.** Tie Tech Inc. 1989.

**Ref ID #TP6**

Notes: This report contains various graphs reporting information of tests concerning wheelchair restraint system evaluation and structural integrity.

## **DEVICES**

91. Morgan P. **New Device Secures Wheelchairs on Boats.** Denver. 1990; (In Press).

**Ref ID #RP34**

Keywords: WHEELCHAIR, RESTRAINT DEVICE

Notes: Rolling, sliding or falling on the bouncing decks of party boats and fishing vessels doesn't appeal to most wheelchair users. A new device developed by a Colorado man called the "Freedom 2000" will hopefully change "wheeler's" attitudes about boats. The device has shown to be successful in securing wheelchairs to boat decks, allowing users to sit securely in their chairs and concentrate on fishing or

whatever activity they're engaged in. The inventor, Ron Miller of Baily, CO, hopes to begin production of the devices around November 10, 1990.

92. **Downing HA, Rohrs DL, Collins DL. Wheelchair Lock Patent. 1977.**  
**Ref ID #TP18**

Notes: A wheelchair lock for mounting in a vehicle. The vehicle is used for transporting handicapped people who are confined to a wheelchair. The lock receives a portion of the ground wheels of the wheelchair and secures the wheels thereto. The lock is manually or electrically operated for quickly releasing the wheels when it is desired to remove the wheelchair from the wheelchair lock.

93. **Quick-Acting Clamps for Machines and Fixtures. 1991.**  
**Ref ID #TP15**

Notes: This is a package of diagrams illustrating examples of several different locks, latches, clamping devices, fasteners and linkages.

## **VIDEOS**

94. **University of Michigan Crash Tests. 1991.**  
**Ref ID #VS5**

Keywords: video

95. **Collins Mobile-TECH Corporation "Dare to Compare". 1991.**  
**Ref ID #VS15**

Keywords: video

96. **Project Pictures. (UnPub).**  
**Ref ID #PH1**

Keywords: WHEELCHAIR, scooter, Alpha Unit, Beta Unit, SECUREMENT SYSTEM

97. **Sled Test. 1991.**  
**Ref ID #VS4**

Keywords: video

98. **RF 4116 Impact Tests (copy). 1991.**  
**Ref ID #VS3**

Keywords: video

99. **1-Handy DART Van Crash Testing Nov. 1989 2-BC Transit and UBC Accident Research Handy DART Vans with Mobility Aids for Frontal Crash Tests. 1989.**  
**Ref ID #VS2**

Keywords: video

100. **Wheels on Wheels. 1991.**  
**Ref ID #VS1**

Keywords: video

101. **INSTRON TEST of BETA 1 UNIT of 29 Jan 1992. 1992.**  
**Ref ID #VS6**

Keywords: video

102. **INSTRON TEST of BETA 1 UNIT of 29 Jan 1992. 1992.**  
**Ref ID #VS7**  
 Keywords: video
103. **LTD 12/17/91 Tests of BETA 1 UNIT, OSU Transportation Research Institute. 1991.**  
**Ref ID #VS9**  
 Keywords: video
104. **LTD 12/18/91 Tests of BETA 1 UNIT, OSU Transportation Research Institute. 1991.**  
**Ref ID #VS8**  
 Keywords: video
105. **OSU Nov/Dec 91 Tests of BETA 1 UNIT, OSU Transportation Research Institute. 1991.**  
**Ref ID #VS10**  
 Keywords: video
106. **Failure Analysis, March/April 92. 1992.**  
**Ref ID #VS11**  
 Keywords: video
107. **Dec. 29, 1991 Side Slip Tests for Mobie & Rolls. 1991.**  
**Ref ID #VS12**  
 Keywords: video
108. **Title; Program Goals; Chart; Slides.**  
**Ref ID #VS13**  
 Keywords: video
109. **16mm to VHS Transfer, OR 9201-04.**  
**Ref ID #VS14**  
 Keywords: video

## **VENDOR REFERENCES**

### **Securement System**

110. **Fixible. METRO. 1991.**  
**Ref ID #VR72**  
 Keywords: wheelchair securement system  
 Notes: This is a current Fixible METRO brochure along with drawings of the wheelchair securement system provided on the METRO coach.
111. **Mobility Dynamics. Wheelchair Tie Down, Lock Downs and Power Seats Mark I Van Lift. 1991.**  
**Ref ID #VR90**  
 Keywords: wheelchair lift  
 Notes: This contains a listing of retail van division prices, explains the features of the Mark I van, and describes other available products.

112. **American Seating Wheelchair Restraint Seating Systems for Public Transportation Vehicles.** 1990.  
**Ref ID #VR9**  
Notes: The Otaco Seating Co. LTD's wheelchair instructions and advertisement for American Seating wheelchair accommodation and restraint system. 2 copies.
113. **Everest & Jennings, Target Ind. Installation instructions.** 1990.  
**Ref ID #VR118**  
Keywords: WHEELCHAIR  
Notes: Includes Target Industries Speed Lock Tie Down
114. **Q'straint. Wheelchair and Occupant Restraint System for Passengers Using a Wheelchair INSTRUCTIONS FOR USE.** 1991.  
**Ref ID #VR88**  
Keywords: SECUREMENT SYSTEM  
Notes: Instruction on how to tie-down a wheelchair using Q'Straint's patented system.
115. **EZLock. UMTRI Crash Tested Wheelchair Restraint Systems.** 1991.  
**Ref ID #VR116.**  
Keywords: wheelchair restraint system
116. **Kinedyne Corporation. Aeroquip Series L Aircraft Cargo Control Products.** 1987.  
**Ref ID #VR121**  
Notes: Aeroquip Series L track and fitting permit the easiest possible conversion from passenger to cargo carrier, as well as quick removal of aircraft accessories. The light weight track and fittings also permit a flexible varying of load requirements and passenger density.
117. **Kinedyne Corporation. Aeroquip Series G Aircraft Cargo Control Products.** 1987.  
**Ref ID #VR120**  
Keywords: wheelchair tie-down  
Notes: Aeroquip Series G system consists of slotted aluminum track and a variety of end fittings designed to secure passenger seats, cargo and other equipment inside an aircraft or vehicle. Series G systems can also be used for specialized applications such as wheelchair tie-downs for transportation of the handicapped.
118. **Q'straint. Let Safety Tie You Down.** 1991.  
**Ref ID #VR87**  
Keywords: wheelchair securement system  
Notes: This pamphlet explains the features and benefits of Q'straint's tie-down system.
119. **Q'straint. Introduction to Q'Straint.** 1991.  
**Ref ID #VR89**  
Keywords: wheelchair securement  
Notes: This booklet contains quite a bit about the Q'Straint system including it's flexibility, specifications, test methods, test results, and SAE technical paper series.
120. **Q'straint. Wheelchair and Occupant Restraint System for Transportation of the Physically Disabled.** 1991.  
**Ref ID #VR114**  
Keywords: wheelchair securement/restraint  
Notes: This pamphlet describes Q'straint adjustable wheelchair restraint and explains how it works. There is also a history of the evolution of the Q'straint system on the back page.

121. **Braun Features and Accessories.** 1991.  
**Ref ID #VR6**  
Notes: Advertisements for Paratransit van features and accessories, wheelchair and occupant belt/track system, and wheelchair transportation accessories.
122. **Transit-Lock Operating Instructions.** 1991.  
**Ref ID #VR8**  
Notes: Instructions on how to install transit locks and how to lock in wheelchair and how to remove wheelchair.
123. **American Seating. Wheelchair Restraint Seating Systems for Public Transportation Vehicles.** 1991.  
**Ref ID #VR91**  
Keywords: wheelchair restraint system  
Notes: This explains the wheelchair restraint seating systems and describes their versatility.
124. **Wheelchair & Occupant Belt/Track System.** Braun. 1991.  
**Ref ID #VR80**  
Keywords: WHEELCHAIR  
Notes: This is a brochure for the wheelchair & occupant belt/track wall-mounted non-retractable shoulder harness, stock # 17861A and the wheelchair & occupant belt/track with retractable shoulder harness, stock #17863A.
125. **Wheelchair & Occupant Belt/Track System.** Braun. 1991.  
**Ref ID #VR13**  
Keywords: wheelchair securement  
Notes: This brochure describes the wheelchair & occupant belt/track system with wall-mounted non-retractable shoulder harness (lap belt included), stock #16773A, and the wheelchair & occupant belt/track system with retractable shoulder harness (lap belt included), stock # 16774A.
126. **Saf-T-Lock.** Collins. 1979.  
**Ref ID #VR71**  
Keywords: securement  
Notes: There's one time when an absolutely stationary wheelchair is vitally important. That's during handicapped transportation. At that time, movement can result in jolts or accidental injury. The reliable Collins Saf-T-Lock eliminates those possibilities. Three models are available, all of which assure stationary safety. The MANUAL model secures the wheelchair with a manually engaged pin lock. Release is also manual. The SEMI-AUTOMATIC model locks itself when the wheelchair is rolled into position. It is released by pressing a plunger. The ELECTRIC model locks automatically and unlocks electrically with a single button control (located remotely if desired). Each set of Saf-T-Locks has a 3/4" lateral width adjustment to allow use of various sizes of wheelchairs. See the chart below to determine your exact needs.
127. **Flxible information.** Flxible. 1991.  
**Ref ID #VR77**  
Keywords: wheelchair securement  
Notes: This packet contains brochures on the METRO bus and Q'Straint's wheelchair and occupant restraint system for passengers using a wheelchair, as well as Flxible's wheelchair lift operator's handbook, and a description and drawings of the Wheelchair Lift System. A letter from Dave Kossler of the Flxible Corp. to Amy Edwards is attached to the front.

## OTHER

128. **Securement of Wheelchairs and Other Mobility Aids on Transit Vehicles.** Project ACTION. 1990.

**Ref ID #RP23**

Keywords: WHEELCHAIR, lift, securement, scooter, transit vehicle

Notes: In increasing numbers, disabled and older Americans are overcoming physical limitations by using a wide variety of mobility aids to extend their range of travel. The golf carts of the sunbelt neighborhoods are being augmented by personal 3- and 4-wheeled vehicles that can be seen daily on our city sidewalks and public transit systems. As a public or private transit authority, the responsibility of safe, efficient service now is enlarge to affording ridership to people using a wide variety of mobility aids.

In considering not only the many types of mobility aid devices, but the variety and sizes of lifts, and the numerous makes of buses and vans, it can be easily seen that there is no single, definitive solution to accessibility on mass transit vehicles. But, since the need is real and the solutions, although not all-encompassing, are a good beginning, the experience of two transit accessibility leaders can be tapped for guidance. Both Southern California Rapid Transit District (SCRTCD) and Seattle Metro have taken the initiative to involve the ridership in needs assessment and have established policies, educated operators and informed public to achieve greater accessibility in their bus transit systems.

129. OSU Department of Civil Engineering and Department of Mechanical Engineering. **"Universal" Wheelchair Securement System for Transit Vehicles: Proposal.** USDOT/FTA. 1990.

**Ref ID #PP2**

Keywords: International Standards Organization, WHEELCHAIR, SECUREMENT SYSTEM, VEHICLE, PUBLIC TRANSPORTATION, scooter, ADA, 504, OCCUPANT

Notes: The "Universal" wheelchair securement system for transit vehicle project is a continuation of research initiated during the Human Factors in Public Transit Safety project undertaken by Oregon State University for the USDOT Urban Mass Transportation Administration in 1987-1988. Public Transit Agencies are having problems securing power "scooters" and other non traditional style wheelchairs on their transit vehicles using the currently available restraint technology. At the same time the proposed Americans with Disabilities Act (ADA), and the new 504 regulations may mandate that these agencies accommodate all mobility devices in common usage. The proposed project will study the current state of the art in design and use of wheelchair securement systems, and then either design a radically new system or modify an existing system to accommodate the wide range of mobility devices in common usage. The design specifications and guidelines will include the minimum specifications in the proposed International Standards Organization regulations for wheelchair occupant restraint for motor vehicles.

The Transportation research Institute at Oregon State University will undertake the project and continue the active and ongoing working relationships with transit agencies in Oregon, and Washington State. The result of the project will provide the details necessary for finite element analysis of the critical design components and construction and testing of the prototype. The project will provide opportunities for an engineering masters degree project and an engineering masters degree thesis.

130. Hunter-Zaworski KM. **A Universal Securement/Restraint System for Mobility Aids on Public Transportation Vehicles: Proposal.** Project ACTION, Easter Seals. 1990.

**Ref ID #PP1**

Keywords: SECUREMENT/RESTRAINT system, RESTRAINT, mobility aid, PUBLIC TRANSPORTATION, VEHICLE, pupil transportation, WHEELCHAIR, scooter, sport chair, mobility device, 504

Notes: Providing access on public and pupil transportation vehicles to users of wheelchairs is a well established goal of virtually all public transportation agencies. Recently, however, there has been a marked increase in the diversity of styles and types of wheelchairs that are available to wheelchair users, for example, power scooters, lightweight sport chairs, and special purpose chairs. These pose a significant new problem to public transportation agencies primarily because the securement and restraint systems which have been developed and installed in the past generally are not capable of properly securing many of these new mobility devices.

This problem is particularly acute for fixed route public transit systems where there is little opportunity to provide flexible systems that are capable of accommodating a variety of designs of mobility devices and where systems that are provided must be capable of being used quickly and with a minimum of assistance from the driver. This has led many agencies to reluctantly prohibit the new design mobility devices from their vehicles. Other agencies allow these mobility devices on their vehicles but require the mobility device user to transfer to a regular transit seat and that the mobility device be securely stowed. This latter approach usually requires additional time and driver involvement. A few agencies have developed their own prototype securement/restraint systems for the new design mobility devices but are uncertain about the adequacy of their designs. Proposed new 504 regulations will mandate that the transit agencies transport "all mobility devices that are in common use".

New standards for Pupil Transportation will be released in the Fall of 1990. The problem for pupil transportation agencies is more severe because pupil transportation providers see the new mobility technology five years or more before the public transportation providers. The project outlined in this proposal, the design of a securement/restraint system for wheelchairs, would provide information useful to a number of groups of individuals concerned about this problem. These would include public and pupil transportation officials, physically challenged individuals, wheelchair designers, and manufacturers of wheelchair securement/restraint systems. The information resulting from this project will provide:

1. A comprehensive view of the overall problem associated with the use of the new design mobility devices on public and pupil transportation systems in the United States and Canada.
  2. Identification and evaluation of existing securement/restraint systems developed to address the problem.
  3. Development of technical specifications and design guidelines for a securement/restraint systems.
  4. Development of a design of a securement/restraint system for public transportation.
- The project will also include the following products:
1. Construction of at least six prototypes for use on fixed route, and demand responsive transportation vehicles.
  2. Field test and sled test results of the prototype restraint/securement systems.

131. Wevers HW. **Wheelchair Securement/Passenger Restraint System.** Rehabilitation Digest. 1991; 14, Number 2:11-11.  
**Ref ID #VR115**



**APPENDIX B**  
**CURRENT TECHNOLOGY: Securement Systems and Devices**

---



## APPENDIX B

### CURRENT SECUREMENT SYSTEMS AND DEVICE TECHNOLOGY

The following categories were used to organize the information:

Vehicle application: answering the question - to which vehicle will this system apply?

- 1) Fixed route vehicles, also known as public transportation buses
- 2) Para-transit vehicles, generally small buses, vans, and mini vans; included for information completeness

Mobility Aid categories: answering the question - what mobility aid can be secured with this system? For this research a Base Fleet was selected encompassing the commonly encountered mobility aids. See Base Fleet of Mobility Aids for further information. These are generic in nature.

- 1) Sports wheelchair
- 2) Standard manual wheelchair
- 3) Electric wheelchair
- 4) Power base chair
- 5) 3-wheeled scooter type

Design Application category: this answers the question - who designed the system?

- 1) Vendor designed systems
- 2) Transit agency designed systems
- 3) Others designed systems such as consultant or research labs

Hardware category: this answers the question - what devices does the securement system use?

- 1) Wheel clamp(s)
- 2) Belt(s), generally seat belts
- 3) Other hardware

### DEFINITIONS

Sports wheelchair - having rear wheels that are the spoke type design in the range of 24" in diameter with smaller front wheels; rear wheels with possible camber; weight less than about 22 lbs.

Standard manual wheelchair - having rear wheels that are the spoke type design in the range of 24" in diameter with smaller front wheels; weight about 25-50 lbs.

Electric wheelchair - having rear wheels that are the spoke type design in the range of 24" in diameter with smaller front wheels; rear wheels driven with electric motor; weight up to 200 lbs.

Power base chairs - having all four wheels that are small (in the range of 12" in diameter) and much wider than wheelchair wheels; weight up to 250 lbs.

3-wheeled scooters - having three wheels that are in the size range of the power base

- (A) TRANSIT-LOCK - COLLINS MOBILE-TECH CORP. P.O. Box 2326, Hutchinson, KS 67504-2326  
(ref VR8)

**System Description:** This system is designed for wheelchairs only. It uses a wheel clamp on the rear wheel that is generally installed on the vehicle outboard side. There is a separate seat belt personal restraint available.

**Operation of System:** The passenger backs into the wheel clamp which locks on the wheel rim. Release is accomplished by stepping or pushing on a manual release lever. This system is completely manual in operation.

Vehicle application:

Fixed route — Yes

Para-transit — Yes

Mobility aid:

Sports wheelchair — Yes

Standard manual wheelchair — Yes

Electric wheelchair — Unknown

Power base chair — No

3-wheeled scooter — No

Design application by:

Vendor — Yes

Transit agency — No

Other — No

Hardware type:

Wheel clamp — Yes

Belt — No

Other hardware — No

- (B) SAF-T-LOCK — COLLINS INDUSTRIES INC. SPECIAL PRODUCTS DIVISION. P.O. Box 58,  
Hutchinson, KS 67501 (ref VR71)

**System Description:** This system is designed for wheelchairs only. It uses a wheel a clamp on the rear wheels. There are three models available, manual, electric, and semi-automatic. Personal restraint would be a separate option.

**Operation of System:** The passenger backs into the wheel clamp which locks on the wheel rim. Release is accomplished by stepping or pushing on a manual release lever for manual units and a push button for electric units. This system is either manual or automatic in operation.

Vehicle application:

Fixed route — Yes

Para-transit — Yes

Mobility aid:

Sports wheelchair — Yes

Standard manual wheelchair — Yes

Electric wheelchair — Unknown

Power base chair — No

3-wheeled scooter — No

Design application by:

Vendor — Yes

Transit agency — No

Other — No

Hardware type:

- Wheel clamp — Yes
- Belt — No
- Other hardware — No

- (C) OTACO — AMERICAN SEATING WHEELCHAIR RESTRAINT SEATING SYSTEMS, OTACO SEATING CO. LTD. Haveie Settlement Road, P.O. 2310, Orillia, Ontario L3V 6S2 CANADA (ref VR9)

System Description: This system is designed for wheelchairs only. It uses one wheel clamp on the vehicle outboard side for the rear wheel with a seat belt device for each side of the chair (to be attached to the chair frame). It is intended that only one aisle side seat belt be used with the wheel clamp. A second, outboard side seat belt can be used if the wheel clamp does not fit the wheel of the chair. Personal restraint is provided in addition to the securement system.

Operation of System: The passenger backs into the device which locks on the wheel rim. Belts are attached by the passenger or transit operator. Belt slack is taken up with a ratchet device. Release is accomplished by pushing a lever and unbuckling the seat belts. This system is completely manual in operation.

Vehicle application:

- Fixed route — Yes
- Para-transit — Yes

Mobility aid:

- Sports wheelchair — Yes
- Standard manual wheelchair — Yes
- Electric wheelchair — Unknown
- Power base chair — No
- 3-wheeled scooter — No

Design application by:

- Vendor — Yes
- Transit agency — No
- Other — No

Hardware type:

- Wheel clamp — Yes
- Belt — Yes
- Other hardware — No

- (D) TRANSPORTATION DEVELOPMENT CENTRE, Montreal, Quebec, CANADA — Wheelchair Securement and Passenger Restraint: Issues, Principles and Initiatives. Workshops given by Barbara A. Smith in Canada between November 1987 to June 1988 (ref RP6)

System Description: This system is a concept only with no known working system ever having been produced. It is listed as figure 6 concept 1. The device is a system of belts that has application to wheelchairs and scooters. The belts attach with hooks to the frame of the wheelchair. There is a separate seat belt for personal restraint.

Operation of System: All belts are manually attached to the mobility aid. Belt slack is taken up with a ratchet device.

Vehicle application:

- Fixed route — Yes
- Para-transit — Yes

**Mobility aid:**

- Sports wheelchair — Yes
- Standard manual wheelchair — Yes
- Electric wheelchair — Yes
- Power base chair — Unknown
- 3-wheeled scooter — No

**Design application by:**

- Vendor — No
- Transit agency — No
- Other — Yes

**Hardware type:**

- Wheel clamp — No
- Belt — Yes
- Other hardware — Yes

- (E) SECURE-LOK, GRESHAM DRIVING AIDS, Referenced in the Transportation Development Montreal, Quebec, CANADA — Wheelchair Securement and Passenger Restraint: Issues, Principles and Initiatives. Workshops given by Barbara A. Smith in Canada between November 1987 to June 1988 (ref RP6)

System Description: The system is designed for use on wheelchairs only. Additional devices installed on the wheelchair are required. It is a belt with ratchet device that is attached on the front and rear portions of the chair.

Operation of System: The wheelchair backs into the device and the mobility aid passenger or transit operator must attach the belts to the wheelchair. The system is manual. Personal restraint is available. It is not certain how the slack in the belts is taken up.

**Vehicle application:**

- Fixed route — Yes
- Para-transit — Yes

**Mobility aid:**

- Sports wheelchair — Yes
- Standard manual wheelchair — Yes
- Electric wheelchair — Yes
- Power base chair — Unknown
- 3-wheeled scooter — No

**Design application by:**

- Vendor — Yes
- Transit agency — No
- Other — No

**Hardware type:**

- Wheel clamp — No
- Belt — Yes
- Other hardware — No

- (F) Q'STRAIT, United States. 4248 Ridge Lea Rd., Buffalo, NY 14226 (ref VR 87-89)

System Description: This system is designed for any mobility aid that can have hooks attached to its frame. The system uses belts that attach to the floor of the vehicle and the mobility aid. There is a separate personal restraint available.

Operation of System: All belts must be manually attached to the mobility aid and the slack taken up with a ratchet device.

Vehicle application:

Fixed route — Yes

Para-transit — Yes

Mobility aid:

Sports wheelchair — Yes

Standard manual wheelchair — Yes

Electric wheelchair — Yes

Power base chair — Yes

3-wheeled scooter — Yes

Design application by:

Vendor — Yes

Transit agency — No

Other — No

Hardware type:

Wheel clamp — No

Belt — Yes

Other hardware — No

(G) SPEED LOCK — TARGET INDUSTRIES INC. —address unknown (VR118)

System Description: For electric wheelchairs only. A bracket and latch device in the floor attaches to a frame bolted to the wheelchair.

Operation of System: Automatic latching with a wheelchair mounted motor that engages bars and plates when the wheelchair is positioned over the latches.

Vehicle application:

Fixed route — Yes

Para-transit — Yes

Mobility aid:

Sports wheelchair — Unknown

Standard manual wheelchair — Yes

Electric wheelchair — Yes

Power base chair — No

3-wheeled scooter — No

Design application by:

Vendor — Unknown

Transit agency — No

Other — No

Hardware type:

Wheel clamp — No

Belt — No

Other hardware — Yes

(H) E.Z. LOCK, 2001 Wooddale Blvd, Baten Rouge, LA 70806 (ref VR116)

System Description: A pin and latch device for wheelchairs and power bases. May be adaptable to scooters. The pin is affixed to the mobility aid and the latch to the vehicle.

**Operation of System:** The mobility aid passenger positions their mobility aid down a vee groove until the latch is engaged. Release is through a push button. Personal restraint will be provided as an optional device.

**Vehicle application:**

Fixed route — Yes

Para-transit — Yes

**Mobility aid:**

Sports wheelchair — Unknown

Standard manual wheelchair — Yes

Electric wheelchair — Yes

Power base chair — Yes

3-wheeled scooter — Unknown

**Design application by:**

Vendor — Yes

Transit agency — No

Other — No

**Hardware type:**

Wheel clamp — No

Belt — No

Other hardware — Yes

- (I) THE ELECTRIC DRIVER'S TIE-DOWN — THE BRAUN CORP. 1014 S. Monticello, P.O. Box 310, Winamac, IN 49996 (ref VR11)

**System Description:** A motorized bar and a latch system that attaches to the bottom of a wheelchair and secures it to the vehicle.

**Operation of System:** An electric driver latch comes up from the vehicle floor and latches onto a bar that is on the underside of a wheelchair. Release is activated by a push button. Personal restraint is optional.

**Vehicle application:**

Fixed route — Yes

Para-transit — Yes

**Mobility aid:**

Sports wheelchair — Yes

Standard manual wheelchair — Yes

Electric wheelchair — Yes

Power base chair — No

3-wheeled scooter — No

**Design application by:**

Vendor — Yes

Transit agency — No

Other — No

**Hardware type:**

Wheel clamp — No

Belt — No

Other hardware — Yes



(J) 4 POINT TRACK/BELT TIE-DOWN -- THE BRAUN CORP. 1014 S. Monticello, P.O. Box 310, Winamac, IN 49996 (ref VR11)

System Description: A manual four (4) belt with ratchet tie down system that attaches to the wheelchair frame.

Operation of System: All belts must be attached manually. Personal restraint is optional.

Vehicle application:

Fixed route -- Yes

Para-transit -- Yes

Mobility aid:

Sports wheelchair -- Yes

Standard manual wheelchair -- Yes

Electric wheelchair -- Yes

Power base chair -- Possible

3-wheeled scooter -- Possible

Design application by:

Vendor -- Yes

Transit agency -- No

Other -- No

Hardware type:

Wheel clamp -- No

Belt -- Yes

Other hardware -- No

(K) CAM LOCK REAR WHEEL TIE-DOWN -- THE BRAUN CORP. 1014 S. Monticello, P.O. Box 310, Winamac, IN 49996 (ref VR11)

System Description: A manual wheelchair wheel clamp system. The system uses a two wheel clamp device.

Operation of System: The passenger must back into the wheel clamps and release is by someone stepping on a release lever. Personal restraint is available.

Vehicle application:

Fixed route -- Yes

Para-transit -- Yes

Mobility aid:

Sports wheelchair -- Yes

Standard manual wheelchair -- Yes

Electric wheelchair -- Yes

Power base chair -- No

3-wheeled scooter -- No

Design application by:

Vendor -- Yes

Transit agency -- No

Other -- No

Hardware type:

Wheel clamp -- Yes

Belt -- No

Other hardware -- No

- (L) MANUAL SLIDE BAR TIE-DOWN — THE BRAUN CORP. 1014 S. Monticello, P.O. Box 310, Winamac, IN 49996 (ref VR11)

System Description: A manual wheel clamp system that has a bar slide across the rim. both wheels are clamped when a large bar is engaged.

Operation of System: The system is manual and requires an operator to engage the large bar. Personal restraint is optional.

Vehicle application:

Fixed route — Yes

Para-transit — Yes

Mobility aid:

Sports wheelchair — Yes

Standard manual wheelchair —

Electric wheelchair —

Power base chair —

3-wheeled scooter —

Design application by:

Vendor — Yes

Transit agency — No

Other — No

Hardware type:

Wheel clamp — Yes

Belt — No

Other hardware — No

- (M) MANUAL SLIDE BAR TIE-DOWN — THE BRAUN CORP. 1014 S. Monticello, P.O. Box 310, Winamac, IN 49996 (ref VR11)

System Description: A manual wheel clamp system.

Operation of System:

Vehicle application:

Fixed route — Yes

Para-transit — Yes

Mobility aid:

Sports wheelchair — Yes

Standard manual wheelchair —

Electric wheelchair —

Power base chair —

3-wheeled scooter —

Design application by:

Vendor — Yes

Transit agency — No

Other — No

Hardware type:

Wheel clamp — Yes

Belt — No

Other hardware — No

(N) STRAP-LOK — CREATIVE CONTROLS INC. 32450 Dequindre, Warren, MI 48092 (ref VR78)

System Description: A four point belt system that attaches hooks to the mobility aid frame from tracks in the vehicle floor. A tension device is used to take up belt slack. Personal Restraint is available.

Operation of System: All belts must be attached manually.

Vehicle application:

Fixed route — Yes

Para-transit — Yes

Mobility aid:

Sports wheelchair — Yes

Standard manual wheelchair — Yes

Electric wheelchair — Yes

Power base chair — Unknown

3-wheeled scooter — No

Design application by:

Vendor — Yes

Transit agency — No

Other — No

Hardware type:

Wheel clamp — No

Belt — Yes

Other hardware — No

(O) CHAIR-LOK: CREATIVE CONTROLS INC. 32450 Dequindre, Warren, MI 48092 (ref VR78)

System Description: A latch device that secures the chair to the vehicle floor. Hardware is installed under the chair with the latching mechanism being mounted on the vehicle. Personal restraint is available via belts.

Operation of System: The latching is power driven.

Vehicle application:

Fixed route — Yes

Para-transit — Yes

Mobility aid:

Sports wheelchair — Yes

Standard manual wheelchair — Yes

Electric wheelchair — Yes

Power base chair — No

3-wheeled scooter — No

Design application by:

Vendor — Yes

Transit agency — No

Other — No

Hardware type:

Wheel clamp — No

Belt — No

Other hardware — Yes

(P) 700 SERIES RESTRAINT SYSTEM — TIE-TECH INC. P.O. Box 5226, Lynwood, WA 98046-5226  
(Ref VR86)

System Description: A four point belt system with hooks that attach to the mobility aid. Ratchet devices for the belts remove slack. Tracks are installed in the vehicle floor. A roll bar is part of the personal restraint system.

Operation of System: The system is manual. Belts with hooks are attached to the chair and the slack in the belts is taken up with the ratchet device.

Vehicle application:

Fixed route — Yes

Para-transit — Yes

Mobility aid:

Sports wheelchair — Yes

Standard manual wheelchair — Yes

Electric wheelchair — Yes

Power base chair — Unknown

3-wheeled scooter — No

Design application by:

Vendor — Yes

Transit agency — No

Other — No

Hardware type:

Wheel clamp — No

Belt — Yes

Other hardware — No

(Q) PROTECTOR — ORTHO SAFE SYSTEMS INC. P.O. Box 9435, Trenton, NJ 98650 (ref VR132)

System Description: A four point belt securement system that attaches to the mobility aid from tracks in the vehicle floor. Belt ratchets are used. Personal restraint is available.

Operation of System: A manual system. All belts are attached manually. Slack in the belt is taken up with the ratchet.

Vehicle application:

Fixed route — Yes

Para-transit — Yes

Mobility aid:

Sports wheelchair — Yes

Standard manual wheelchair — Yes

Electric wheelchair — Yes

Power base chair — Unknown

3-wheeled scooter — No

Design application by:

Vendor — Yes

Transit agency — No

Other — No

Hardware type:

Wheel clamp — No

Belt — Yes

Other hardware — No

(R) LANE TRANSIT DISTRICT — LANE TRANSIT DISTRICT. P.O. Box 7071, Eugene, OR 97401  
(ref VR134)

System Description: A four point belt system. Attaches to the mobility aid by looping through or across frame members. Attachment to the vehicle is via bolts and cargo catches. Personal restraint is available with belts.

Operation of System: All belts are manually attached. Slack in the rear belts is taken up with an inertia lock reel, and front belts are tightened by hand.

Vehicle application:

Fixed route — Yes

Para-transit — Yes

Mobility aid:

Sports wheelchair — Yes

Standard manual wheelchair — Yes

Electric wheelchair — Yes

Power base chair — Yes

3-wheeled scooter — Yes

Design application by:

Vendor — No

Transit agency — Yes

Other — No

Hardware type:

Wheel clamp — Yes

Belt — No

Other hardware — No

(S) MTC II WHEELCHAIR SECUREMENT — METROPOLITAN TRANSIT COMMISSION. 560 6th Ave.  
North, Minneapolis, MN 55411-4398 (ref RP19)

System Description: A three point belt system. Attachment to the mobility aid is through loops in the belt ends that go through the wheelchair frame members. Personal restraint is available with belts. Attachment to the vehicle is through bolts.

Operation of System: All belts are attached manually with the slack being taken up by an inertia lock reel on the belts.

Vehicle application:

Fixed route — Yes

Para-transit — Yes

Mobility aid:

Sports wheelchair — Yes

Standard manual wheelchair — Yes

Electric wheelchair — Yes

Power base chair — Unknown

3-wheeled scooter — No

Design application by:

Vendor — No

Transit agency — Yes

Other — No

Hardware type:

- Wheel clamp — No
- Belt — Yes
- Other hardware — No

(T) MIDCOAST ENTERPRISES. Florence, OR 97434 (ref PR1)

System Description: A four belt securement system for three wheeled mobility aids. Additionally wedges are placed on each wheel. The belts are attached to the floor of the vehicle and are tightened down over the scooter floorboards.

Operation of System: All belts are manually connected.

Vehicle application:

- Fixed route — Yes
- Para-transit — Yes

Mobility aid:

- Sports wheelchair — Unknown
- Standard manual wheelchair — Unknown
- Electric wheelchair — Unknown
- Power base chair — No
- 3-wheeled scooter — Yes

Design application by:

- Vendor — No
- Transit agency — Yes
- Other — No

Hardware type:

- Wheel clamp — No
- Belt — Yes
- Other hardware — No

(U) SOUTHERN CALIFORNIA RAPID TRANSIT DISTRICT — PLANNING DEPT. 425 South Main St., Los Angeles, CA 90013 (ref RP23)

System Description: Both a wheel clamp and seat belts are used for this system. Inertia ratchets are used to take up the slack in the seat belts. The wheel clamp is a commercial unit. All parts are bolted to the vehicle. Personal restraint is part of the system.

Operation of System: Operation of the wheel clamp is the same as all commercial units with a manual lever for release. All belts must be installed manually.

Vehicle application:

- Fixed route — Yes
- Para-transit — Yes

Mobility aid:

- Sports wheelchair — Yes
- Standard manual wheelchair — Yes
- Electric wheelchair — Yes
- Power base chair — Unknown
- 3-wheeled scooter — Yes

Design application by:  
Vendor — No  
Transit agency — Yes  
Other — No  
Hardware type:  
Wheel clamp — Yes  
Belt — Yes  
Other hardware — No

- (V) SEATTLE METRO — MUNICIPALITY OF METROPOLITAN SEATTLE. 11911 East Marginal Way South Building A, Seattle, WA 98168 (ref RP23)

System Description: A wheel clamp and seat belt is used for this system. The wheel clamp is a standard commercial unit. The seat belts have an inertia locking device. All parts are bolted to the vehicle.

Operation of System: All belts are attached manually. The wheel clamp is released with a manual lever.

Vehicle application:  
Fixed route — Yes  
Para-transit — Yes  
Mobility aid:  
Sports wheelchair — Yes  
Standard manual wheelchair — Yes  
Electric wheelchair — Yes  
Power base chair — No  
3-wheeled scooter — No  
Design application by:  
Vendor — Yes  
Transit agency — No  
Other — No  
Hardware type:  
Wheel clamp — Yes  
Belt — No  
Other hardware — No

- (W) WHEEL BRACKET DEVICE — Designed by DOUGLAS BALL INC. 88 Ste-Anne Street, Str-Anne-de-Bellevue, Quebec H9X 1LB for Transportation Development Centre, Transport Canada under Multimodal Wheelchair Securement/Passenger Restraint Prototype Development, project #TP 3057E (ref. RP12)

System Description: The system has two brackets that attach over the rear wheels of a wheelchair. These brackets come out from a retracting device mounted behind the wheelchair in the vehicle wall. Personal restraint is part of the device mounted behind the wheelchair.

Operation of System: The passenger or the transit operator must manually pull the bracket out and put it over the wheels. The system is completely manual.

Vehicle application:  
Fixed route — Yes  
Para-transit — Yes

Mobility aid:

- Sports wheelchair — Possible
- Standard manual wheelchair — Yes
- Electric wheelchair — Yes
- Power base chair — No
- 3-wheeled scooter — No

Design application by:

- Vendor — No
- Transit agency — No
- Other — Yes

Hardware type:

- Wheel clamp — No
- Belt — No
- Other hardware — Yes

- (X) STANDARD INTERFACE CONCEPT — T E S LIMITED. P.O. Box 9372, Ottawa, Canada K1G 3V1  
(ref ST30)

System Description: A hook and bar device that comes up from the vehicle floor and latches to bars that are under the mobility aid frame. Personal restraint could be provided.

Operation of System: All automatic, powered by cylinders in the vehicle floor.

Vehicle application:

- Fixed route — Yes
- Para-transit — Yes

Mobility aid:

- Sports wheelchair — Yes
- Standard manual wheelchair — Yes
- Electric wheelchair — Yes
- Power base chair — No
- 3-wheeled scooter — No

Design application by:

- Vendor — No
- Transit agency — No
- Other — Yes

Hardware type:

- Wheel clamp — No
- Belt — No
- Other hardware — Yes

**Additionally:** In the TES Report C839-1, Development of a Wheelchair Securement System, Interim Report 1, p. 28 Table 5, "Summary of Commercially Available Wheelchair Securement Systems Reprint", lists 51 systems of the types; Belts, T-bars, Rod and Hook, Wheel on Rim Locks, Floor Mounted Lock ins, and other devices.

## CONCLUSION

From the patent search, present commercial transit agency and other design reports for securement systems, it appears that there are three types of devices presently being used: The Wheel Clamp, a modified seat belt arrangement, and a few other hardware mechanisms.



**APPENDIX C**  
**CUSTOMER QUESTIONNAIRE, WEIGHING SCALE AND SUMMARY**

---



**APPENDIX C**

**CUSTOMER WEIGHTING QUESTIONNAIRE**

**Customer Requirements for a Universal Securement/Restraint System for  
Mobility Aids on Public Transportation Vehicles**

Your Name:  
Your Title:  
Your Company:  
Your Address:  
Your Phone:  
Your Fax:

Which group are you in?

- Mobility-aid passenger
- Transit system - operator
- Transit system - maintenance
- Transit system - management
- Transit vehicle manufacturer
- Mobility-aid manufacturer
- Other passengers
- Standard groups / other organizations
- Securement systems manufacturer

Please return this questionnaire  
to:

Kate Hunter-Zaworski  
Transportation Research  
Institute  
Oregon State University  
100 Merryfield Hall  
Corvallis, OR 97331-4304

QUESTIONNAIRE SECTION 1

THE SECUREMENT SYSTEM IS EASY TO USE

THE RATING SCALE: MARK                    5 FOR EXTREMELY IMPORTANT  
   4 FOR VERY IMPORTANT  
   3 FOR IMPORTANT  
   2 FOR NOT TOO IMPORTANT  
   1 FOR NOT IMPORTANT

CIRCLE ONE

- 5-4-3-2-1 : 1. The mobility-aid passenger can remain in mobility-aid.
- 5-4-3-2-1 : 2. The mobility-aid passenger will need minimal training.
- 5-4-3-2-1 : 3. The securement system can be used in only one obvious way.
- 5-4-3-2-1 : 4. The transit operator will need minimal training.
- 5-4-3-2-1 : 5. The passenger's 'personal space' is not invaded during securement.
- 5-4-3-2-1 : 6. The securement system will allow easy positioning of mobility-aid.
- 5-4-3-2-1 : 7. The securement system will allow easy connection of mobility-aid.
- 5-4-3-2-1 : 8. The securement system will allow easy utilization of personal restraint.
- 5-4-3-2-1 : 9. The securement system will allow easy disconnection of mobility-aid.
- 5-4-3-2-1 : 10. The securement system will allow adjustability for any commonly used mobility-aid.
- 5-4-3-2-1 : 11. The securement system shall be easy and neat to stow.
- 5-4-3-2-1 : 12. The securement system shall be easy and neat to retrieve.
- 5-4-3-2-1 : 13. The connection to securement system shall require minimal use of tools.
- 5-4-3-2-1 : 14.

QUESTIONNAIRE SECTION 2

**THE SECUREMENT SYSTEM OPERATION**

THE RATING SCALE: MARK

- 5 FOR EXTREMELY IMPORTANT
- 4 FOR VERY IMPORTANT
- 3 FOR IMPORTANT
- 2 FOR NOT TOO IMPORTANT
- 1 FOR NOT IMPORTANT

CIRCLE ONE

- 5-4-3-2-1 : 1. The securement system shall be activated or conveniently engaged and released by mobility-aid passenger.
- 5-4-3-2-1 : 2. The securement system shall be activated when contacted by the mobility-aid and released by passenger or transit operator.
- 5-4-3-2-1 : 3. The securement system will have fast securement to the mobility-aid.
- 5-4-3-2-1 : 4. The securement system will have fast release from the mobility-aid.
- 5-4-3-2-1 : 5. The securement system will provide optional passenger restraint.
- 5-4-3-2-1 : 6. The securement system will operate as designed in hot, wet, cold, salty, or snowy conditions.
- 5-4-3-2-1 : 7. Transit system operator interaction with passenger shall be minimal.
- 5-4-3-2-1 : 8. \_

QUESTIONNAIRE SECTION 3

MOBILITY-AID REQUIREMENTS FOR THE SECUREMENT  
SYSTEM

THE RATING SCALE: MARK

- 5 FOR EXTREMELY IMPORTANT
- 4 FOR VERY IMPORTANT
- 3 FOR IMPORTANT
- 2 FOR NOT TOO IMPORTANT
- 1 FOR NOT IMPORTANT

CIRCLE ONE

5-4-3-2-1 : 1. No modification of the mobility-aid will be required.

5-4-3-2-1 : 2.

## QUESTIONNAIRE SECTION 4

### THE SECUREMENT SYSTEM ENERGY CONTROL

THE RATING SCALE: MARK

- 5 FOR EXTREMELY IMPORTANT
- 4 FOR VERY IMPORTANT
- 3 FOR IMPORTANT
- 2 FOR NOT TOO IMPORTANT
- 1 FOR NOT IMPORTANT

#### CIRCLE ONE

- 5-4-3-2-1 : 1. The securement system will restrain mobility-aid without damage during normal acceleration.
- 5-4-3-2-1 : 2. The securement system will restrain mobility-aid without damage during normal deceleration.
- 5-4-3-2-1 : 3. The securement system will restrain mobility-aid without damage during normal cornering.
- 5-4-3-2-1 : 4. The securement system will restrain mobility-aid without damage during accident acceleration forward.
- 5-4-3-2-1 : 5. The securement system will restrain mobility-aid without damage during accident acceleration rearward.
- 5-4-3-2-1 : 6. The securement system will restrain mobility-aid without damage during accident acceleration sideways.
- 5-4-3-2-1 : 7. The securement system will control energy transfer to mobility-aid.
- 5-4-3-2-1 : 8. The securement system will restrain movement of mobility-aid during normal starts and stops forward.
- 5-4-3-2-1 : 9. The securement system will restrain movement of mobility-aid during normal starts and stops rearward.
- 5-4-3-2-1 : 10. The securement system will restrain movement of mobility-aid while cornering.
- 5-4-3-2-1 : 11. The securement system hardware will be positive latch type.
- 5-4-3-2-1 : 12. The mobility-aid wheels will not slip on wet floor of mobility-aid station.
- 5-4-3-2-1 : 13.

QUESTIONNAIRE SECTION 5

THE SECUREMENT SYSTEM DAMAGE POTENTIAL

THE RATING SCALE: MARK

- 5 FOR EXTREMELY IMPORTANT
- 4 FOR VERY IMPORTANT
- 3 FOR IMPORTANT
- 2 FOR NOT TOO IMPORTANT
- 1 FOR NOT IMPORTANT

CIRCLE ONE

- 5-4-3-2-1 : 1. The securement system materials shall not stain, soil, or tear any passenger's clothing or hands.
- 5-4-3-2-1 : 2. The securement system shall not be able to be over-tightened.
- 5-4-3-2-1 : 3. The securement system shall be free of sharp edges.
- 5-4-3-2-1 : 4. The securement system shall be non-corrosive.
- 5-4-3-2-1 : 5. The securement system will not be capable of causing harm to other passengers.
- 5-4-3-2-1 : 6. When not being used, the securement system shall be reasonably protected from vandalism.
- 5-4-3-2-1 : 7.

QUESTIONNAIRE SECTION 6

WHILE THE SECUREMENT SYSTEM IS IN USE

- 5-4-3-2-1 : 1. The mobility-aid shall be forward facing.
- 5-4-3-2-1 : 2. The mobility-aid station shall have a limited volume.
- 5-4-3-2-1 : 3. The securement system will not interfere with other passengers.
- 5-4-3-2-1 : 4.



QUESTIONNAIRE SECTION 7

WHILE THE SECUREMENT SYSTEM IS STOWED

THE RATING SCALE: MARK                    5 FOR EXTREMELY IMPORTANT  
    4 FOR VERY IMPORTANT  
    3 FOR IMPORTANT  
    2 FOR NOT TOO IMPORTANT  
    1 FOR NOT IMPORTANT

CIRCLE ONE

5-4-3-2-1 : 1. The securement system shall not interfere with other passengers.

5-4-3-2-1 : 2.

QUESTIONNAIRE SECTION 8

THE SECUREMENT SYSTEM UNDER FLOOR SPACE SHALL BE MINIMAL

5-4-3-2-1 : 1. The space under the floor used for the securement system will be minimal.

5-4-3-2-1 : 2.

QUESTIONNAIRE SECTION 9

THE SECUREMENT SYSTEM EQUIPMENT COST

5-4-3-2-1 : 1. The cost per mobility-aid station will be reasonable.

5-4-3-2-1 : 2. The cost per mobility-aid will be reasonable.

5-4-3-2-1 : 3.

QUESTIONNAIRE SECTION 10

SECUREMENT SYSTEM USEFUL LIFE

THE RATING SCALE: MARK

- 5 FOR EXTREMELY IMPORTANT
- 4 FOR VERY IMPORTANT
- 3 FOR IMPORTANT
- 2 FOR NOT TOO IMPORTANT
- 1 FOR NOT IMPORTANT

CIRCLE ONE

5-4-3-2-1 : 1. The securement system useful life will equal the vehicle useful life.

5-4-3-2-1 : 2.

QUESTIONNAIRE SECTION 11

STURDINESS OF THE SECUREMENT SYSTEM

5-4-3-2-1 : 1. The securement system will appear sturdy.

5-4-3-2-1 : 2.

QUESTIONNAIRE SECTION 12

SECUREMENT SAFETY

5-4-3-2-1 : 1. Red colors will identify emergency release mechanisms.

5-4-3-2-1 : 2. The securement system will not become inoperable if mobility-aid tires are deflated.

5-4-3-2-1 : 3.

QUESTIONNAIRE SECTION 13

**MAINTENANCE TIME REQUIREMENTS FOR THE SECUREMENT SYSTEM**

THE RATING SCALE: MARK

- 5 FOR EXTREMELY IMPORTANT
- 4 FOR VERY IMPORTANT
- 3 FOR IMPORTANT
- 2 FOR NOT TOO IMPORTANT
- 1 FOR NOT IMPORTANT

CIRCLE ONE

5-4-3-2-1 : 1. The securement system will require minimal maintenance time.

5-4-3-2-1 : 2.

QUESTIONNAIRE SECTION 14

**MAINTENANCE RETROFIT REQUIREMENTS OF THE SECUREMENT SYSTEM**

5-4-3-2-1 : 1. The securement system can be retrofitted to all vehicles.

5-4-3-2-1 : 2.

QUESTIONNAIRE SECTION 15

**FEATURES OF THE SECUREMENT SYSTEM**

5-4-3-2-1 : 1. The securement system shall be easy to clean.

5-4-3-2-1 : 2.

QUESTIONNAIRE AVERAGES FOR ALL CUSTOMER GROUPS

CUSTOMER REQUIREMENT CODE	SECTION 1 : THE SECUREMENT SYSTEM IS EASY TO USE QUESTION#	MAP	TO	TM	TE	VM	MAM	OP	SG	SSM	TOTAL UNWEIGHTED	TOTAL WEIGH
1.1.1	1.1	5.00	4.33	5.00	4.70	0.00	5.00	5.00	4.60	0.00	3.74	4.81
1.1.2	1.2	4.50	3.25	4.60	4.60	0.00	5.00	5.00	4.60	0.00	3.51	4.47
1.1.3	1.3	4.50	4.00	4.60	4.30	0.00	4.00	5.00	4.60	0.00	3.44	4.44
1.1.4	1.4	4.25	3.25	4.40	4.30	0.00	3.00	5.00	4.60	0.00	3.20	4.27
1.1.5	1.5	4.00	3.50	4.40	4.30	0.00	3.00	5.00	4.60	0.00	3.20	4.21
1.1.6.1	1.6	4.25	4.25	4.60	4.30	0.00	3.00	5.00	4.20	0.00	3.29	4.33
1.1.6.2	1.7	3.92	4.25	4.80	4.20	0.00	3.00	5.00	4.20	0.00	3.26	4.22
1.1.6.3	1.8	3.92	3.50	4.80	4.00	0.00	2.00	5.00	4.20	0.00	3.05	4.10
1.1.6.4	1.9	3.58	4.00	4.40	4.10	0.00	1.00	5.00	4.20	0.00	2.92	4.00
1.1.6.5	1.10	3.92	4.25	4.40	4.10	0.00	1.00	5.00	3.80	0.00	2.94	4.08
1.1.7.1	1.11	3.50	4.00	4.20	3.70	0.00	1.00	5.00	3.80	0.00	2.80	3.78
1.1.7.2	1.12	3.67	3.75	3.80	3.90	0.00	1.00	2.00	3.80	0.00	2.44	3.73
1.1.8	1.13	3.50	3.75	4.00	3.90	0.00	1.00	2.00	2.00	0.00	2.24	3.45
SECTION 2 : THE SECUREMENT SYSTEM OPERATION												
QUESTION#												
1.2.1	2.1	4.67	4.25	4.60	4.20	0.00	5.00	5.00	4.80	0.00	3.61	4.52
	2.1	4.33	3.50	4.20	4.20	0.00	4.00	5.00	3.80	0.00	3.23	4.15
1.2.2.1	2.3	4.17	4.25	3.80	4.60	0.00	3.00	5.00	3.80	0.00	3.18	4.22
1.2.2.2	2.4	4.08	4.50	3.80	3.80	0.00	3.00	5.00	3.40	0.00	3.06	3.93
1.2.3	2.5	3.08	3.00	3.60	3.10	0.00	2.00	5.00	3.40	0.00	2.58	3.25
1.2.4	2.6	3.42	4.00	3.60	3.70	0.00	1.00	4.00	3.20	0.00	2.55	3.56
1.2.5	2.7	2.92	2.50	3.40	3.40	0.00	1.00	3.00	3.20	0.00	2.16	3.13
SECTION 3 : MOBILITY-AID REQUIREMENTS FOR THE SECUREMENT SYSTEM												
QUESTION#												
1.3.1	3.1	4.50	3.75	3.80	3.11	0.00	5.00	3.00	3.40	0.00	2.95	3.76
SECTION 4 : THE SECUREMENT SYSTEM ENERGY CONTROL												
QUESTION#												
1.4.1.1	4.1	4.83	4.00	4.60	5.00	0.00	5.00	5.00	5.00	0.00	3.71	4.81
1.4.1.2	4.2	4.75	4.25	4.60	4.90	0.00	5.00	5.00	5.00	0.00	3.72	4.77
1.4.1.3	4.3	4.67	4.00	4.60	4.90	0.00	5.00	5.00	5.00	0.00	3.69	4.72
1.4.2.1	4.4	4.33	3.75	4.20	4.30	0.00	5.00	5.00	4.20	0.00	3.42	4.26
1.4.2.2	4.5	4.00	3.50	3.80	4.30	0.00	5.00	5.00	4.20	0.00	3.31	4.07
1.4.2.3	4.6	4.00	3.50	4.00	4.20	0.00	5.00	5.00	4.20	0.00	3.32	4.07
1.4.3	4.7	3.82	3.75	4.40	4.50	0.00	2.00	5.00	3.60	0.00	3.01	4.09
1.4.4.1	4.8	4.08	4.25	4.20	4.50	0.00	2.00	4.00	3.60	0.00	2.96	4.16
1.4.4.2	4.9	4.00	3.75	4.00	4.20	0.00	2.00	4.00	3.60	0.00	2.84	3.98
1.4.5	4.10	3.92	4.25	4.00	4.30	0.00	1.00	4.00	3.40	0.00	2.76	3.99
1.4.6	4.11	3.58	3.25	4.20	3.90	0.00	1.00	4.00	3.40	0.00	2.59	3.72
1.4.7	4.12	3.75	3.75	3.60	3.90	0.00	1.00	3.00	2.40	0.00	2.38	3.56
SECTION 5 : THE SECUREMENT SYSTEM DAMAGE POTENTIAL												
QUESTION#												
1.5.1	5.1	4.42	4.25	4.80	4.90	0.00	5.00	5.00	5.00	0.00	3.71	4.69
1.5.2	5.2	4.08	4.00	4.40	4.50	0.00	3.00	5.00	4.60	0.00	3.29	4.33
1.5.3.1	5.3	4.08	4.00	4.60	4.70	0.00	2.00	5.00	4.40	0.00	3.20	4.39
1.5.3.2	5.4	3.92	3.75	4.60	4.30	0.00	2.00	5.00	4.20	0.00	3.09	4.17

QUESTIONNAIRE AVERAGES FOR ALL CUSTOMER GROUPS

CUSTOMER	MAP	TO	TM	TE	VM	MAM	OP	SG	SSM			
1.5.4	5.5	3.92	4.00	4.20	4.40	0.00	1.00	4.00	3.40	0.00	2.77	4.03
1.5.5	5.6	3.50	3.75	3.80	4.20	0.00	1.00	3.00	3.00	0.00	2.47	3.67
SECTION 6 : WHILE THE SECUREMENT SYSTEM IS IN USE												
QUESTION#												
2.1.1	6.1	4.17	3.25	4.60	3.80	0.00	2.00	5.00	4.00	0.00	2.98	4.05
2.1.2	6.2	4.09	3.00	4.00	3.56	0.00	2.00	5.00	4.00	0.00	2.85	3.85
2.1.3	6.3	3.67	3.25	4.40	3.50	0.00	1.00	3.00	2.80	0.00	2.40	3.55
SECTION 7 : WHILE THE SECUREMENT SYSTEM IS STOWED												
QUESTION#												
2.2.1	7.1	3.58	3.75	4.60	4.00	0.00	1.00	5.00	4.00	0.00	2.88	3.95
SECTION 8 : THE SECUREMENT SYSTEM UNDER FLOOR SPACE SHALL BE MINIMAL												
QUESTION#												
2.3	8.1	2.33	3.25	3.40	3.50	0.00	1.00	3.00	2.80	0.00	2.14	2.97
SECTION 9 : THE SECUREMENT SYSTEM EQUIPMENT COST												
QUESTION#												
3.1.1	9.1	3.58	3.00	4.00	3.30	0.00	5.00	5.00	3.80	0.00	3.08	3.58
3.1.2	9.2	3.58	3.00	3.25	3.40	0.00	1.00	0.00	2.80	0.00	1.89	3.23
SECTION 10 : SECUREMENT SYSTEM USEFUL LIFE												
QUESTION#												
3.2.1	10.1	3.58	3.00	4.20	3.80	0.00	1.00	5.00	3.60	0.00	2.69	3.72
SECTION 11 : STURINESS OF THE SECUREMENT SYSTEM												
QUESTION#												
4.1.1	11.1	3.08	3.75	3.60	3.50	0.00	1.00	1.00	2.80	0.00	2.08	3.23
SECTION 12 : SECUREMENT SAFETY												
QUESTION#												
5.1.1	12.1	3.08	3.50	4.40	3.80	0.00	4.00	5.00	3.20	0.00	3.00	3.57
5.1.2	12.2	2.75	3.00	4.00	3.80	0.00	1.00	5.00	3.20	0.00	2.53	3.36
SECTION 13 : MAINTENANCE TIME REQUIREMENTS FOR THE SYSTEM												
QUESTION#												
6.1.1	13.1	3.58	3.25	4.20	3.60	0.00	1.00	4.00	2.60	0.00	2.47	3.52
SECTION 14 : MAINTENANCE RETROFIT REQUIREMENTS FOR THE SYSTEM												
QUESTION#												
6.2.1	14.1	3.83	4.00	4.40	3.90	0.00	2.00	5.00	4.00	0.00	3.01	4.00
SECTION 15 : FEATURES OF THE SECUREMENT SYSTEM												
QUESTION#												
6.3.1	15.1	3.33	3.75	4.40	3.70	0.00	1.00	3.00	3.20	0.00	2.49	3.59
CUSTOMER	MAP	TO	TM	TE	VM	MAM	OP	SG	SSM	TOTAL		
NUMBER OF RESPON	12	3	5	10	0	1	1	5	0	37		
AVERAGE FOR	3.88	3.70	4.20	4.07	0.00	2.53	4.32	3.80	0.00			
ALL QUESTI ONS												



**APPENDIX D**  
**BASE FLEET AND CENTER OF GRAVITY DIAGRAMS**

---





## APPENDIX D

### BASE FLEET AND CENTER OF GRAVITY DIAGRAMS

#### INTRODUCTION

The discussion will focus on five generic classes of mobility aids and the characteristics of each class as they pertain to the securement problem.

#### MOBILITY AIDS

There are over 500 models and styles of mobility aids in use today. Mobility aids that are in "common use" in the adult market will be discussed in five generic classes. These classes cover most aids, however there are some mobility aids that bridge between two classes and there are others special purpose devices that do not fit any of the classes.

#### Mobility Aid Classes

For purposes of this discussion a base fleet of five generic classes of mobility aids has been devised.

#### Manual Wheelchairs

The manual wheelchair consists of two large wheels with two smaller castors in front. Figure 1 shows a typical manual wheelchair. In general, the frame of the wheelchair permits the wheelchair to be folded. Manual or standard wheelchairs usually have detachable armrests and footrests which permit transfers in and out of the chair.

#### Sports or Lightweight Wheelchairs

Sports style wheelchairs are very similar to standard wheelchairs with the exception that they are generally much lighter, have smaller castors in the front, and possibly cambered wheels in the rear. Sports wheelchairs usually have a rigid frame (do not fold) but rather have quick release wheels to ease storage. By eliminating the folding feature, the wheelchair can be made much lighter. Figure 2 shows a typical sports style wheelchair. Sports chairs often have a much shorter wheelbase than a standard chair so they are more maneuverable, and are stripped down to included the minimum of accessories such as arm rests.

#### Electric Wheelchairs

Electric Wheelchairs look like standard wheelchairs with large rear wheels and smaller front castors. Electric motors, batteries and controllers are added to the frame. The large drive wheels are usually much wider and more robust than those on a standard wheelchair frame. Figure 3 shows an electric wheelchair. There is a tremendous variety of power transmission and control systems for electric wheelchairs, but they are all essentially configured as shown in the illustration.

#### Powered Base

A powered base wheelchair usually consists of three or four medium sized wheels. All the motors, batteries and controllers are underneath the seat on a powered base. Many of the powered bases are modular so that they can be easily broken down into components such as the steering column, batteries, motors and wheels, controller, and seat for transport in a personal vehicle. Figure 4 shows a powered base. Powered base mobility aids are generally robust and heavy for use outdoors and over rough terrain.

**Three Wheeled Scooters**

There are many styles and models of three wheeled scooters. Three wheel scooters are generally much lighter than a power base and have smaller wheels. Figure 5 illustrates a typical power scooter. For rear wheel drive models, the batteries and motors are underneath the seat and the steering column is attached to the front wheel. For front wheel drive models, the batteries are underneath the seat, but the motor and controller are attached to the front drive wheel. There are several three wheeled mobility aids that are very robust and could also be classified at powered bases.

**Mobility Aid Weight and Center of Gravity**

To develop the mechanics of secured mobility aids it is necessary to have information on the weight and center of gravity locations of both the mobility aid and the passenger. To find this information for the mobility aid, a small project was undertaken to determine the center of gravity of a number of representative models. The horizontal center of gravity location was calculated from weight measurements made at each axle of the mobility aid. The vertical center of gravity location was found by balancing the chair on its rear wheels for standard and sports wheelchairs. The battery powered units center of gravity was measured by weighing each wheel, then lifting one end of the vehicle four inches and reweighing the wheels. A summary of the data is shown in Table D-1. All values in this table have an error band of  $\pm 1$  inch (25 mm) and  $\pm 2$  lbs (1 kg). The vertical center of gravity distance is measured from the floor. The horizontal center of gravity distance is measured forward from the center of the rear axle.

TABLE D-1. SUMMARY OF MEASURED DEVICES

Model	Type	Vertical CG in./(mm)	Horizontal CG in./(mm)	Weight lbs/(kg)
Invacare Rolls 1000	Standard Wheelchair	12.0 (305)	7.0 (178)	40.0 (18)
Kuschell Champion 3000	Sport Chair	12.0 (305)	5.3 (135)	23.0 (10.4)
Rolls Arrow	Electric Wheelchair	10.0 (254)	6.2 (157)	169.0 (77)
Fortress-Scientific 655FS	Power Base	9.0 (229)	7.5 (190)	209.0 (95)
Fortress-Scientific 2000FS	Scooter	9.0 (229)	8.6 (218)	180.5 (82)
Everest & Jennings Carrette	Scooter	7.5 (190)	9.3 (236)	174.5 (79)
Invacare Tri-Rolls	Scooter	Not Available	8.2 (208)	147.5 (67)
Amigo RWD	Scooter	7.5 (190)	8.2 (208)	129.0 (59)
Average of 4 Scooters Tested	Scooter	8.0 (203)	8.6 (218)	158.0 (72)

### Mobility Aid Passengers Characteristics

Passengers in mobility aids have a wide range of weights and weight distributions. To cover this range, data for the 95th percentile males (1), and 5th percentile females (2) were studied. Lumped mass occupant models were used for the determination of the center of gravity. The model does not account for atrophy of the lower extremity, asymmetry, or occupant biomechanics which may be unique due to paralysis or muscle weakness. Table D-2 shows the center of gravity measurements for seated 5th percentile female and 95th percentile male mobility aid passengers. The horizontal distance is measured from the seat back, and the vertical distance is measured from the bottom of the feet. Figures 6-10 illustrate the center of gravity of the mobility aid, the passenger, and the combination of the passenger and mobility aid.

TABLE D-2. CENTER OF GRAVITY INFORMATION OF THE MOBILITY AID PASSENGER

95th Percentile Male Weight	216 pounds	(97.2 kg)
Vertical Distance of Center of Gravity	26 in.	(666 mm)
Horizontal Distance of Center of Gravity	9 in.	(230 mm)
5th Percentile Female Weight	102 pounds	(46.0 kg)
Vertical Distance of Center of Gravity	20.5 in.	(525 mm)
Horizontal Distance of Center of Gravity	7 in.	(179 mm)

### OPERATING CONDITIONS

In order to discuss the mechanics of securement systems, it is necessary to know the conditions in which they must operate. Requirements on securement systems fall into two broad classes, the transfer of forces between the mobility aid and the vehicle carrying it and the human factors involved in fastening and releasing the system. This discussion is only focused on the transfer of forces, and the mechanics of the securement systems.

The forces on a mobility aid that might make it move, bend or break are created by the motions of the vehicle in which the mobility aid is secured. These forces are generated by accelerations of the vehicle. These accelerations are transformed into forces in accordance with a simplified version of Newtons Law ( $F = m \times A$ ). According to this law, the mass ( $m$ ) of the mobility aid and passenger, and the amount of acceleration ( $A$ ) on the vehicle are known then the force ( $F$ ) on the securement system can be found. The mass of the mobility aid and passenger is equal to the weight in pounds divided by gravity ( $32.2 \text{ ft/s}^2$ ). In SI units the mass of the mobility aid and passenger is given in kilograms. In the previous section the weight of a sample of mobility aids and representative passengers were itemized, this section will focus on identifying the accelerations that can be expected to put loads on the securement system. The accelerations are summarized in Figure 11. The remainder of this section is focused on explaining the information in this figure. All values in this figure are given in terms of "g". Simply explained, if a vehicle containing a 250 pound mobility aid and passenger combination accelerates at 1 g, the force on the securement system will be 250 pounds. If it accelerates at 10 g's, the force will be 2500 pounds.

Essentially, there are two types of vehicles that are used to transport mobility aids: fixed route vehicles and demand vehicles. Fixed route vehicles, buses that run on a set schedule and circuit are generally large, greater than 30,000 Gross Vehicle Weight, have limited acceleration capabilities, seldom back up, corner slowly and, except in accident conditions put low load on the mobility aid or securement system. Demand vehicles on the other hand range from common passenger vans to modified truck beds. These vehicles are smaller, lighter, and more maneuverable than the fixed route vehicles.

An additional classification that must be made is the operating situation of the vehicle. Specifically, each type of vehicle spends most of its time under what can be called "normal operating conditions". These include all potential operations where the vehicle does not hit any other object nor tip over. Generally, for

normal operating conditions, the accelerations of the vehicle are low. Even though most vehicles spend their entire operating life within the normal operating conditions, "accident conditions" must also be accounted for. As shown in Figure 11 accident conditions result in much higher accelerations than normal operating conditions.

The last variable in Figure 11 is the direction of the acceleration of the vehicle. There are three directions of concern here. Each is defined in terms of the direction of the force placed on the securement system:

- (1) **Forward:** The securement system holds the mobility aid from moving or pitching forward. This force is caused by the vehicle braking under normal operating conditions or when it hits something head on in accident conditions. Accelerations causing forward forces are often called decelerations.
- (2) **Sideward:** The securement system holds the mobility aid from moving or rocking side to side. This force is caused by the vehicle turning a corner under normal operating conditions or when hit from the side in accident conditions.
- (3) **Rearward:** The securement system holds the mobility aid from moving or pitching backward. This force is caused by the vehicle accelerating or when it is braking while backing up under normal conditions, or when it is impacted from the rear in accident conditions. Shown in the figure is the acceleration in each of the major directions for each of the two types of vehicles in each operating situation. In the text below the source for each of the values and the limitations on them are discussed.

#### **Fixed Route Vehicle, Normal Operating Conditions**

The values shown are estimates for the accelerations for fixed route vehicles operating normally. The forward acceleration value of 0.4 g is based on standards set for the maximum braking capability of large vehicles. Specifically, according to (3), vehicles over 10,000 pounds must decelerate at least  $3.7 \text{ m/sec}^2$ . This equivalent to  $12 \text{ ft/sec}^2$  or 0.4 g. According to (4), tests have shown that the maximum forward deceleration experienced by a bus is 0.8-1.0 g.

The sideward value of 0.2 g is an estimate as there are no known standards or measurements for sideward accelerations or forces on restraint systems in fixed route vehicles. Acceleration measurements for sideward accelerations on large transit buses were between 0.3 and 0.37 g for severe operating conditions.

The rearward value of 0.1 g is based on the limited acceleration possible with the throttle restrictors used on all buses. It is possible for a bus to achieve a higher rate by backing up and braking hard, however this condition seldom occurs in normal operating situations.

#### **Fixed Route Vehicle, Accident Conditions**

The values shown in the figure are estimates for the accelerations for fixed route vehicles in accident situations. The forward acceleration value of 10 g is based on a number of measurements and standards. This has been confirmed by BC Transit tests where they impacted a bus and a van in a head-on collision (5). The maximum deceleration of the bus was 10 g with a duration of about 0.1 sec. The value of 10 g's has been adopted by some agencies as a guideline (USDOT), and proposed in other standards (ISO). In some standards and guidelines this is translated into a force on the securement system. Specifically, if the mobility aid and passenger weigh 400 pounds, then the force on the securement system will be 4000 pounds ( $10 * 400$ ) applied horizontally at the center of gravity. This value is what is given in (4).

The sideward value of 2 g was developed through calculations. If a standard sized car (1,000 kg (2220 lb)) hits a stationary light bus (10,000 kg (22,000 lb)) in the side at 50 kph (31 mph), the bus will experience a sideward acceleration of 1.3 g. If hit by another bus of the same weight at 17 kph (10 mph) the bus hit from the side will experience an acceleration of 2.3 g. Based on these values and a lack of other published data the value of 2.0 g has been selected.

The rearward value of 2 g is based on the same assumptions as the sideward situation.

**Demand Vehicle, Normal Operating Conditions**

The values shown are estimates for the accelerations for demand vehicles operating normally. All values are .8 g based on the results from tests which were performed to find the maximum forces and displacements on a scooter restrained by a four belt system (6). The vehicle used in these tests was a standard 1990 Ford chassis with a custom body designed to transport mobility aids. This vehicle was run through a series of tests including: maximum acceleration at full throttle, maximum braking, constant radius turns and swerving maneuvers. The results show that the maximum accelerations that this vehicle can produce without hitting anything or rolling over is about 0.8 g in any direction. This value occurs when braking either forward or backward or when swerving or otherwise turning as sharp as possible. Note that the braking performance while backing up is far more severe than the force exerted when accelerating as hard as possible.

**Demand Vehicle, Accident Conditions**

The values shown are estimates for the accelerations for demand vehicles operating under accident conditions. Most standards and testing of securement devices are based on the forward value of 20 g's for this case. Experimental data for a van hitting a cement wall at 30 mph (50 kph) ranges to 30 g's for a very short period, (5) and 10 g's for a van hitting a bus. The values of 10 g for both rear and side impact was based on this latter experimental value supported by calculations. In effect if a bus hits a stationary van at 30 mph (50 kph) the resulting acceleration on the van will be 10 g regardless of direction.

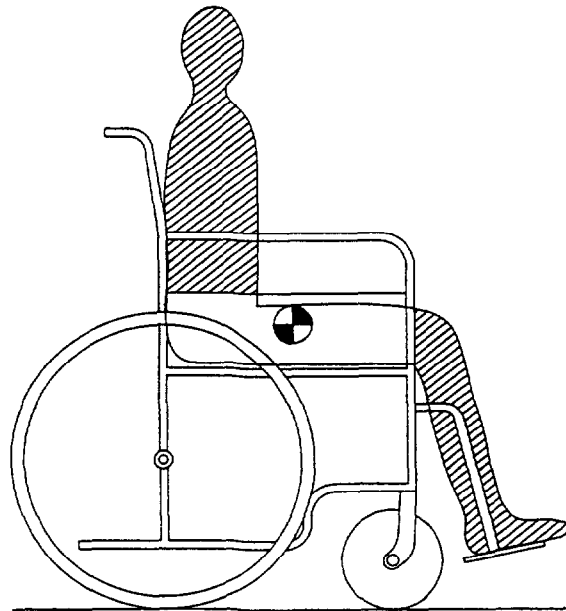

Figure 1 Manual or Standard Wheelchair

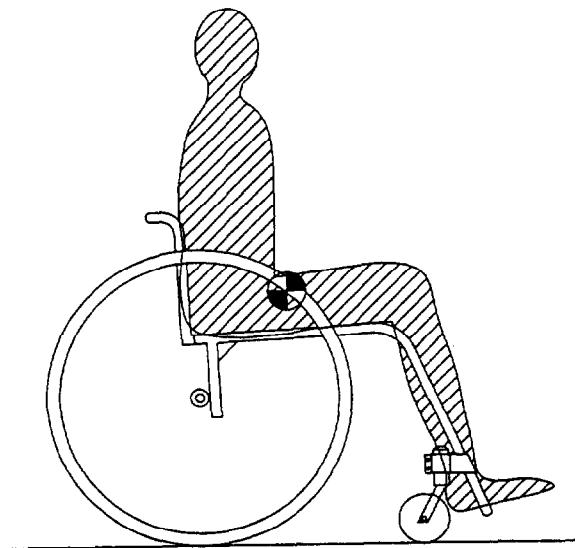

Figure 2 Sports or Lightweight Wheelchair

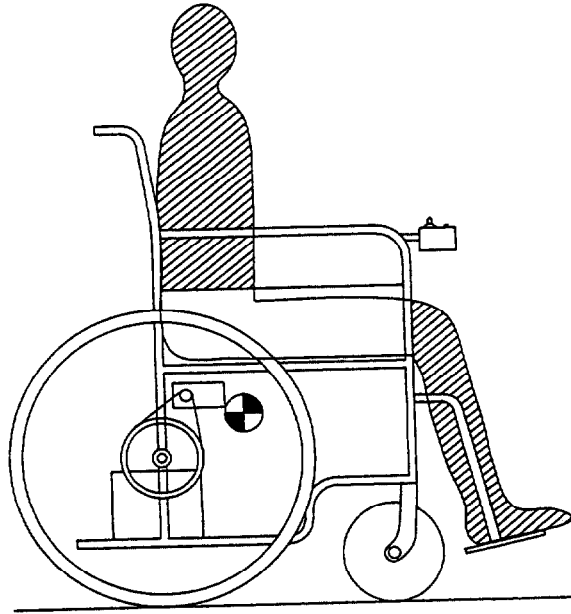

Figure 3 Electric Wheelchair

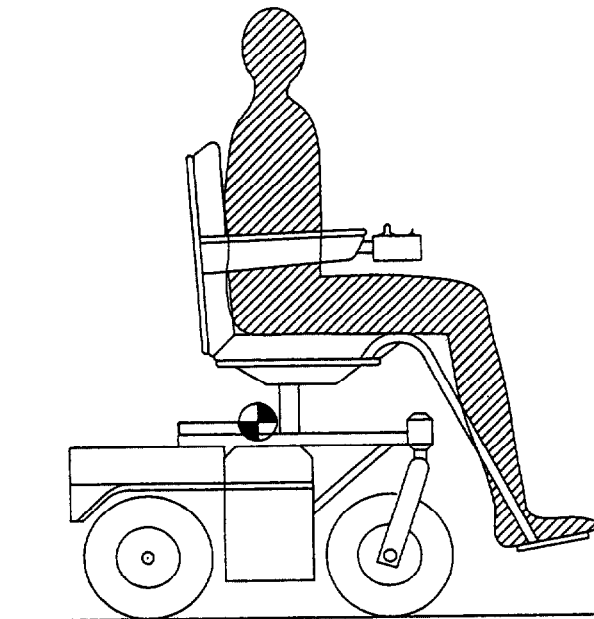

Figure 4 Powered Base

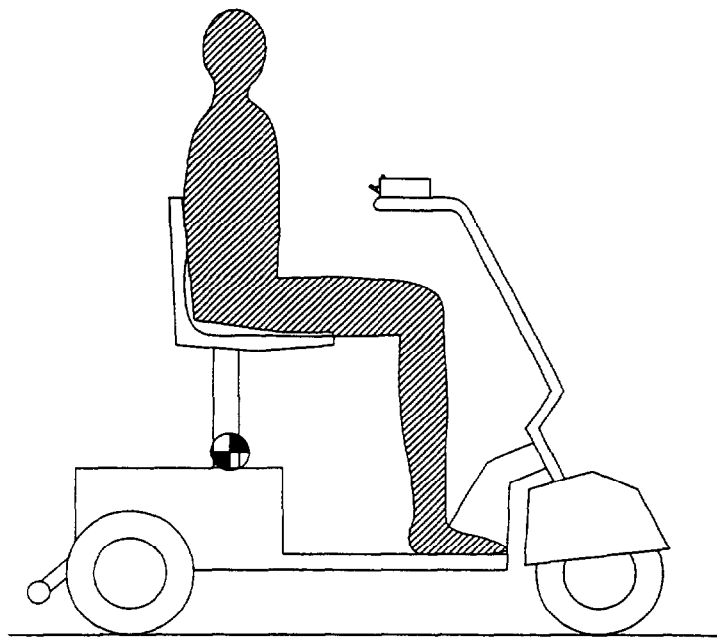

Figure 5 Three Wheeled Scooter



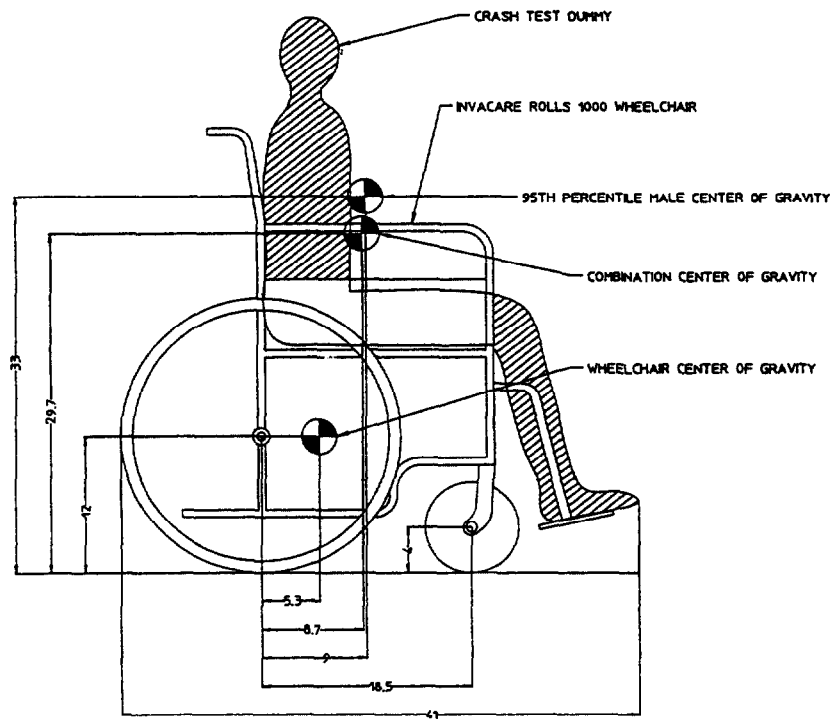

Figure 6 Center of Gravity of Standard Wheelchair with 95% Male Passenger

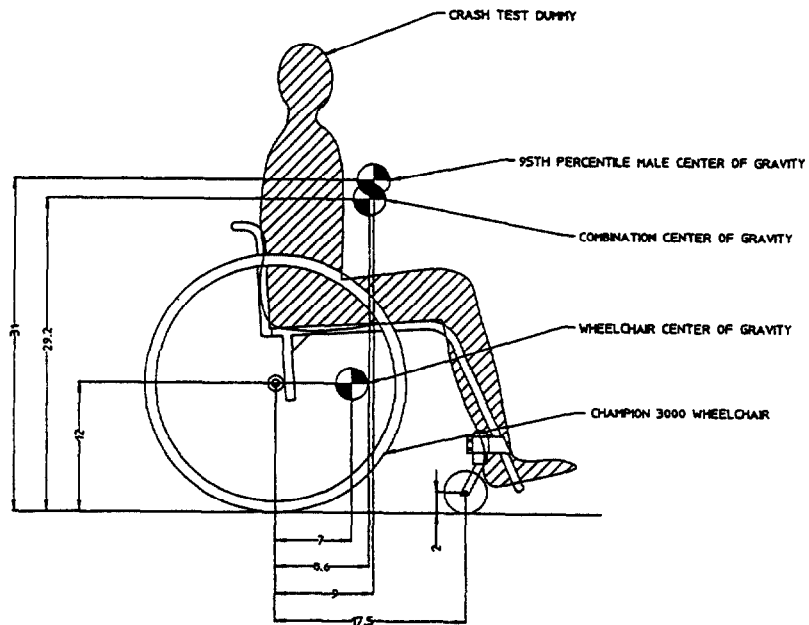

Figure 7 Center of Gravity of Sports Wheelchair with 95% Male Passenger

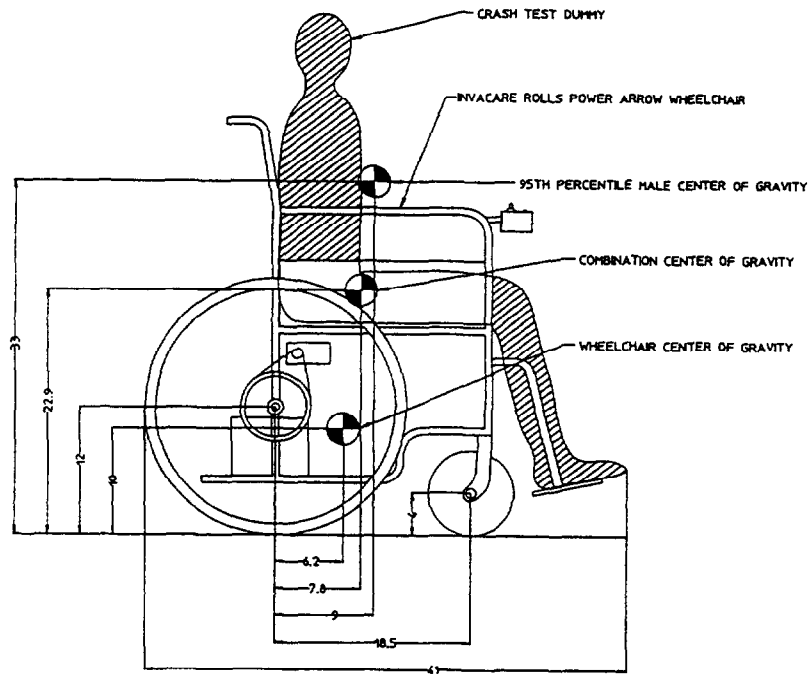

Figure 8 Center of Gravity of Electric Wheelchair with 95% Male Passenger

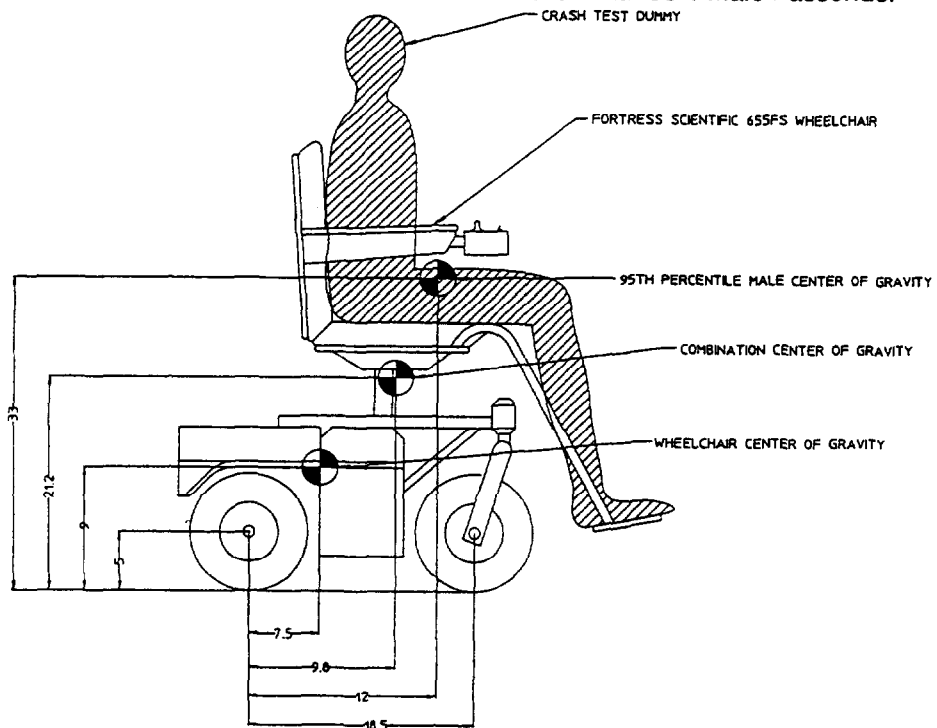

Figure 9 Center of Gravity of Powered Base with 95% Male Passenger

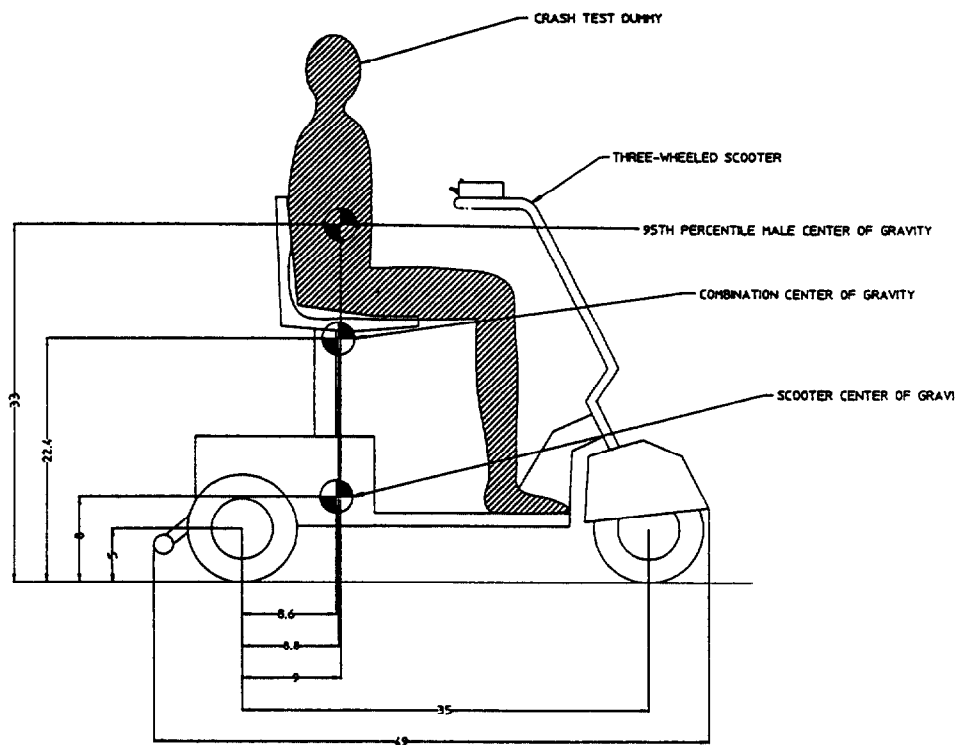
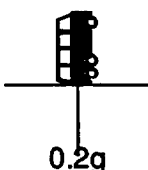
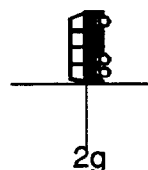
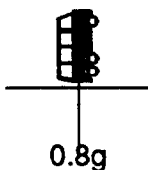
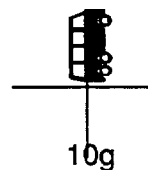

Figure 10 Center of Gravity of Three Wheeled Scooter with 95% Male Passenger

	Normal Operations	Accident
Fixed Route Vehicle	<p>0.4g</p> <p>0.1g</p>  <p>0.2g</p>	<p>10g</p> <p>2g</p>  <p>2g</p>
Demand Vehicle	<p>0.8g</p> <p>0.8g</p>  <p>0.8g</p>	<p>20g</p> <p>10g</p>  <p>10g</p>

KEY

Side

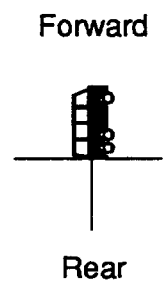

Figure 11 OPERATING CONDITIONS (g forces)

**APPENDIX E**  
**FUNCTIONAL DECOMPOSITION OF DEVICE REQUIREMENTS**

---



## APPENDIX E

### FUNCTIONAL DECOMPOSITION OF DEVICE REQUIREMENTS

**FUNCTION : 1.0**

**ACTION :** Prepare - transit operator prepare mobility aid station for mobility aid passenger that is boarding

**ACTOR :** Transit Operator and Mobility Aid Station

**INITIAL STATE OF ACTOR :** In Other Passenger Configuration

**FINAL STATE OF ACTOR :** Ready to receive Mobility Aid

**PRECEDING FUNCTION :** None

**SUCCEEDING FUNCTION :** 2.0

**PARALLEL FUNCTION :** None

**MATERIAL FLOW TO :**

**ENERGY FLOW TO :**

**INFORMATION FLOW TO :**

**MATERIAL FLOW FROM :**

**ENERGY FLOW FROM :**

**INFORMATION FLOW FROM :**

**ENERGY FORM :**

**INFORMATION :**

**INFORMATION FORM :**

**ASSUMPTIONS :**

**FUNCTION : 1.1**

**ACTION :** Move - other passengers move out of mobility aid station

**ACTOR :** Other passengers

**INITIAL STATE OF ACTOR :** Seated in the Mobility Aid Station seating

**FINAL STATE OF ACTOR :** In other seating

**PRECEDING FUNCTION :** 1.0

**SUCCEEDING FUNCTION :** 1.2

**PARALLEL FUNCTION :** None

**MATERIAL FLOW TO :** Other seating

**ENERGY FLOW TO :** NA

**INFORMATION FLOW TO :** Transit operator and Mobility aid passenger

**MATERIAL FLOW FROM :** Mobility aid station seating

**ENERGY FLOW FROM :** NA

**INFORMATION FLOW FROM :**

**ENERGY FORM :** NA

**INFORMATION :** that mobility aid is boarding

**INFORMATION FORM :** visual

**ASSUMPTIONS :** that other people will vacate the seating in the mobility aid station when they see a mobility aid boarding

**FUNCTION : 1.2**

**ACTION :** Prepare - Transit operator prepares the mobility aid station

**ACTOR :** Transit Operator

**INITIAL STATE OF ACTOR :** In the vehicle cockpit

**FINAL STATE OF ACTOR :** at the mobility aid station

**PRECEDING FUNCTION :** 1.1

**SUCCEEDING FUNCTION :** 1.3

**PARALLEL FUNCTION :** none

**MATERIAL FLOW TO :** Mobility aid station

**ENERGY FLOW TO :** Mobility aid station

**INFORMATION FLOW TO :** Transit operator

**MATERIAL FLOW FROM :** cockpit

**ENERGY FLOW FROM :** Transit operator

**INFORMATION FLOW FROM :** Mobility aid station

**ENERGY FORM :** mechanical

**INFORMATION :** that other passenger have vacated mobility aid station

**INFORMATION FORM :** visual

**ASSUMPTIONS :** that the transit operator is physically required to prepare the mobility aid station

FUNCTION : 1.3

ACTION : Verify - transit operator and mobility aid passenger to verify that mobility aid station is ready to accept mobility aid

ACTOR : Transit operator and mobility aid passenger

INITIAL STATE OF ACTOR : transit operator and mobility aid passenger at mobility aid station, mobility aid passenger has boarded

FINAL STATE OF ACTOR : mobility aid ready to position in mobility aid station

PRECEDING FUNCTION : 1.2

SUCCEEDING FUNCTION : 2.0

PARALLEL FUNCTION : none

MATERIAL FLOW TO : NA

ENERGY FLOW TO : NA

INFORMATION FLOW TO : transit operator and mobility aid passenger

MATERIAL FLOW FROM : NA

ENERGY FLOW FROM : NA

INFORMATION FLOW FROM : Mobility aid station

ENERGY FORM : NA

INFORMATION : that mobility aid station is ready to receive mobility aid

INFORMATION FORM : visual

ASSUMPTIONS : None

FUNCTION : 2.0

ACTION : Position - the mobility aid passenger must position the mobility aid into mobility aid station and securement station

ACTOR : Mobility Aid

INITIAL STATE OF ACTOR : Mobility aid not connected to securement system

FINAL STATE OF ACTOR : Mobility aid ready for securement to securement system

PRECEDING FUNCTION : 1.3

SUCCEEDING FUNCTION : 2.1

PARALLEL FUNCTION : None

MATERIAL FLOW TO : securement system

ENERGY FLOW TO : NA

INFORMATION FLOW TO : transit operator and mobility aid passenger

MATERIAL FLOW FROM : transit vehicle aisle

ENERGY FLOW FROM : NA

INFORMATION FLOW FROM : Mobility aid station

ENERGY FORM : NA

INFORMATION : that the mobility aid is correctly positioned in securement system

INFORMATION FORM : visual

ASSUMPTIONS : that the mobility aid passenger does all the positioning

FUNCTION : 2.1

ACTION : Move - mobility aid passenger moves the mobility aid moves into mobility aid station and securement system

ACTOR : Mobility aid

INITIAL STATE OF ACTOR : mobility aid is in the aisle

FINAL STATE OF ACTOR : mobility aid is correctly positioned in the mobility aid station and securement system

PRECEDING FUNCTION : 1.3

SUCCEEDING FUNCTION : 2.2

PARALLEL FUNCTION : none

MATERIAL FLOW TO : securement system

ENERGY FLOW TO : NA

INFORMATION FLOW TO : mobility aid passenger and transit operator

MATERIAL FLOW FROM : vehicle aisle

ENERGY FLOW FROM : NA

INFORMATION FLOW FROM : Mobility aid station

ENERGY FORM : NA

INFORMATION : that mobility aid is moving correctly into mobility aid station and securement system

INFORMATION FORM : visual

ASSUMPTIONS : none

FUNCTION : 2.2

ACTION : Verify Position - transit operator or mobility aid passenger to verify that mobility aid is correctly positioned in the mobility aid station

ACTOR : Transit Operator and Mobility Aid Passenger

INITIAL STATE OF ACTOR : uncertain that mobility aid is in correct position

FINAL STATE OF ACTOR : knowledge that mobility aid is correctly positioned

PRECEDING FUNCTION : 2.1

SUCCEEDING FUNCTION : 3.0



PARALLEL FUNCTION : none  
MATERIAL FLOW TO : NA  
ENERGY FLOW TO : NA  
INFORMATION FLOW TO : Mobility aid passenger and transit operator  
MATERIAL FLOW FROM : NA  
ENERGY FLOW FROM : NA  
INFORMATION FLOW FROM : Mobility aid station and securement system  
ENERGY FORM : NA  
INFORMATION : that mobility aid is correctly positioned in securement system  
INFORMATION FORM : visual  
ASSUMPTIONS : none

FUNCTION : 3.0  
ACTION : Secure - secure mobility aid in securement system  
ACTOR : Mobility aid and Securement System  
INITIAL STATE OF ACTOR : mobility aid not secured in securement system  
FINAL STATE OF ACTOR : mobility aid secured in securement system  
PRECEDING FUNCTION : 2.0  
SUCCEEDING FUNCTION : 4.0  
PARALLEL FUNCTION : none  
MATERIAL FLOW TO : securement system  
ENERGY FLOW TO : NA  
INFORMATION FLOW TO : transit operator and mobility aid passenger  
MATERIAL FLOW FROM : correct position in mobility aid station  
ENERGY FLOW FROM : NA  
INFORMATION FLOW FROM : securement system  
ENERGY FORM : NA  
INFORMATION : that the mobility aid is in securement system  
INFORMATION FORM : various - mechanical and visual  
ASSUMPTIONS : none

FUNCTION : 3.1  
ACTION : Attach - transit operator or mobility aid passenger attaches securement system to mobility aid or mobility aid connects to securement system  
ACTOR : Mobility Aid  
INITIAL STATE OF ACTOR : not attached to securement system  
FINAL STATE OF ACTOR : attached to securement system  
PRECEDING FUNCTION : 2.2  
SUCCEEDING FUNCTION : 3.2  
PARALLEL FUNCTION : none  
MATERIAL FLOW TO : securement system  
ENERGY FLOW TO : securement system  
INFORMATION FLOW TO : none  
MATERIAL FLOW FROM : correct position in mobility aid station  
ENERGY FLOW FROM : mobility aid  
INFORMATION FLOW FROM : none  
ENERGY FORM : mechanical  
INFORMATION : that mobility aid is attaching to the securement system  
INFORMATION FORM : audible or visual  
ASSUMPTIONS :

FUNCTION : 3.2  
ACTION : Verify Attachment - transit operator or mobility aid passenger to verify that the mobility aid is correctly attached to the securement system  
ACTOR : Transit Operator or Mobility Aid Passenger  
INITIAL STATE OF ACTOR : correct attachment condition unknown  
FINAL STATE OF ACTOR : correct attachment condition known  
PRECEDING FUNCTION : 3.1  
SUCCEEDING FUNCTION : 4.0  
PARALLEL FUNCTION : none  
MATERIAL FLOW TO : NA  
ENERGY FLOW TO : NA  
INFORMATION FLOW TO : transit operator and mobility aid passenger  
MATERIAL FLOW FROM : NA  
ENERGY FLOW FROM : NA

**INFORMATION FLOW FROM** : securement system  
**ENERGY FORM** : NA  
**INFORMATION** : that the mobility aid is correctly attached to the securement system  
**INFORMATION FORM** : visual  
**ASSUMPTIONS** : that correct attachment can be known

**FUNCTION** : 4.0  
**ACTION** : Hold - securement system to hold mobility aid  
**ACTOR** : Securement System and mobility aid  
**INITIAL STATE OF ACTOR** : mobility aid attached to the securement system  
**FINAL STATE OF ACTOR** : mobility aid attached to the securement system  
**PRECEDING FUNCTION** : 3.0  
**SUCCEEDING FUNCTION** : 5.0  
**PARALLEL FUNCTION** : none  
**MATERIAL FLOW TO** : none  
**ENERGY FLOW TO** : securement system  
**INFORMATION FLOW TO** : mobility aid passenger  
**MATERIAL FLOW FROM** : none  
**ENERGY FLOW FROM** : mobility aid  
**INFORMATION FLOW FROM** : securement system  
**ENERGY FORM** : mechanical  
**INFORMATION** : that mobility aid is being held in securement system  
**INFORMATION FORM** : visual and audible  
**ASSUMPTIONS** :

**FUNCTION** : 4.1  
**ACTION** : Restrain - securement system to restrain mobility aid movement within limits under normal operating conditions  
**ACTOR** : Securement System and mobility aid  
**INITIAL STATE OF ACTOR** : mobility aid attached to the securement system  
**FINAL STATE OF ACTOR** : mobility aid attached to the securement system  
**PRECEDING FUNCTION** : 3.0  
**SUCCEEDING FUNCTION** : 5.0  
**PARALLEL FUNCTION** : none  
**MATERIAL FLOW TO** : none  
**ENERGY FLOW TO** : securement system  
**INFORMATION FLOW TO** : mobility aid passenger  
**MATERIAL FLOW FROM** : none  
**ENERGY FLOW FROM** : mobility aid  
**INFORMATION FLOW FROM** : securement system  
**ENERGY FORM** : mechanical  
**INFORMATION** : that mobility aid is being held in securement system  
**INFORMATION FORM** : visual and audible  
**ASSUMPTIONS** :

**FUNCTION** : 4.2  
**ACTION** : Hold - Securement system to hold mobility aid during accident conditions  
**ACTOR** : Securement System and mobility aid  
**INITIAL STATE OF ACTOR** : mobility aid attached to the securement system  
**FINAL STATE OF ACTOR** : mobility aid attached to the securement system  
**PRECEDING FUNCTION** : 3.0  
**SUCCEEDING FUNCTION** : 5.0  
**PARALLEL FUNCTION** : none  
**MATERIAL FLOW TO** : none  
**ENERGY FLOW TO** : securement system  
**INFORMATION FLOW TO** : mobility aid passenger  
**MATERIAL FLOW FROM** : none  
**ENERGY FLOW FROM** : mobility aid  
**INFORMATION FLOW FROM** : securement system  
**ENERGY FORM** : mechanical  
**INFORMATION** : that mobility aid is being held in securement system  
**INFORMATION FORM** : visual and audible  
**ASSUMPTIONS** :

**FUNCTION : 5.0**

**ACTION : Release - securement system to release mobility aid from securement system when demanded**

**ACTOR : Securement System and mobility aid**

**INITIAL STATE OF ACTOR : mobility aid attached to the securement system**

**FINAL STATE OF ACTOR : mobility aid released from the securement system**

**PRECEDING FUNCTION : 4.0**

**SUCCEEDING FUNCTION : 6.0**

**PARALLEL FUNCTION : none**

**MATERIAL FLOW TO : none**

**ENERGY FLOW TO : securement system**

**INFORMATION FLOW TO : mobility aid passenger**

**MATERIAL FLOW FROM : none**

**ENERGY FLOW FROM : securement system release mechanism**

**INFORMATION FLOW FROM : securement system release mechanism**

**ENERGY FORM : mechanical**

**INFORMATION : that mobility aid is being released from the securement system**

**INFORMATION FORM : audible or visual**

**ASSUMPTIONS :**

**FUNCTION : 5.1**

**ACTION : Activate - transit operator or mobility aid passenger to activate release mechanism**

**ACTOR : Mobility aid passenger or transit operator and release mechanism**

**INITIAL STATE OF ACTOR : normal riding condition**

**FINAL STATE OF ACTOR : ready to depart from mobility aid station**

**PRECEDING FUNCTION : 4.1**

**SUCCEEDING FUNCTION : 5.2**

**PARALLEL FUNCTION : none**

**MATERIAL FLOW TO : none**

**ENERGY FLOW TO : securement system release device**

**INFORMATION FLOW TO : transit operator or mobility aid passenger**

**MATERIAL FLOW FROM : none**

**ENERGY FLOW FROM :**

**INFORMATION FLOW FROM :**

**ENERGY FORM : electrical or mechanical**

**INFORMATION : that the release device is releasing**

**INFORMATION FORM : visual**

**ASSUMPTIONS :**

**FUNCTION : 5.2**

**ACTION : Release - that the securement system is releasing the mobility aid**

**ACTOR : securement system release device**

**INITIAL STATE OF ACTOR : the securement system is holding the mobility aid**

**FINAL STATE OF ACTOR : the mobility aid is released from the securement system**

**PRECEDING FUNCTION : 4.1**

**SUCCEEDING FUNCTION : 5.1**

**PARALLEL FUNCTION : none**

**MATERIAL FLOW TO : none**

**ENERGY FLOW TO : securement system release mechanism**

**INFORMATION FLOW TO : transit operator or mobility aid passenger**

**MATERIAL FLOW FROM : none**

**ENERGY FLOW FROM : securement system activation device**

**INFORMATION FLOW FROM : securement release device**

**ENERGY FORM : electrical - mechanical**

**INFORMATION : that the release device is working**

**INFORMATION FORM : visual - audible**

**ASSUMPTIONS :**

**FUNCTION : 5.3**

**ACTION : Verify - transit operator or mobility aid passenger to verify that mobility aid is released from the securement system**

**ACTOR : transit operator or mobility aid passenger**

**INITIAL STATE OF ACTOR : knowledge of securement system release device unknown**

**FINAL STATE OF ACTOR : knowledge of securement system release device knowledge known**

**PRECEDING FUNCTION : 5.2**

**SUCCEEDING FUNCTION : 6.0**

**PARALLEL FUNCTION : none**

**MATERIAL FLOW TO :** none  
**ENERGY FLOW TO :** none  
**INFORMATION FLOW TO :** transit operator or mobility aid passenger  
**MATERIAL FLOW FROM :** none  
**ENERGY FLOW FROM :** none  
**INFORMATION FLOW FROM :** securement system  
**ENERGY FORM :** none  
**INFORMATION :** that the mobility aid is released from the securement system  
**INFORMATION FORM :** visual  
**ASSUMPTIONS :**

**FUNCTION :** 6.0  
**ACTION :** Move - Mobility aid and Mobility aid passenger move out of mobility aid station  
**ACTOR :** Mobility Aid  
**INITIAL STATE OF ACTOR :** Mobility aid is released from the securement system but is still in the mobility aid station  
**FINAL STATE OF ACTOR :** ready to depart from the vehicle  
**PRECEDING FUNCTION :** 5.0  
**SUCCEEDING FUNCTION :** 7.0  
**PARALLEL FUNCTION :** none  
**MATERIAL FLOW TO :** front of vehicle  
**ENERGY FLOW TO :** none  
**INFORMATION FLOW TO :** transit operator and other passengers  
**MATERIAL FLOW FROM :** mobility aid station  
**ENERGY FLOW FROM :** none  
**INFORMATION FLOW FROM :** mobility aid  
**ENERGY FORM :** none  
**INFORMATION :** that mobility aid is disembarking  
**INFORMATION FORM :** visual  
**ASSUMPTIONS :**

**FUNCTION :** 7.0  
**ACTION :** Return - Transit operator returns mobility aid station to other passenger configuration  
**ACTOR :** Transit operator  
**INITIAL STATE OF ACTOR :** At mobility aid station  
**FINAL STATE OF ACTOR :** Back in operation cockpit  
**PRECEDING FUNCTION :** 6.0  
**SUCCEEDING FUNCTION :** none  
**PARALLEL FUNCTION :** none  
**MATERIAL FLOW TO :** to operator cockpit  
**ENERGY FLOW TO :** none  
**INFORMATION FLOW TO :** other passengers  
**MATERIAL FLOW FROM :** mobility aid station  
**ENERGY FLOW FROM :** none  
**INFORMATION FLOW FROM :** transit operator and mobility aid station  
**ENERGY FORM :** none  
**INFORMATION :** that mobility aid station has been returned to other passenger configuration  
**INFORMATION FORM :** visual  
**ASSUMPTIONS :** that transit operation had to go to mobility aid station to assist mobility aid passenger release himself from the securement system

**FUNCTION :** 7.1  
**ACTION :** Verify - verify that mobility aid has left mobility aid station  
**ACTOR :** Transit Operator  
**INITIAL STATE OF ACTOR :** knowledge that mobility aid has left mobility aid station is unknown  
**FINAL STATE OF ACTOR :** knowledge that mobility aid station is cleared of mobility aid is known  
**PRECEDING FUNCTION :** 6.0  
**SUCCEEDING FUNCTION :** 7.2  
**PARALLEL FUNCTION :** none  
**MATERIAL FLOW TO :** none  
**ENERGY FLOW TO :** none  
**INFORMATION FLOW TO :** transit operator  
**MATERIAL FLOW FROM :** none  
**ENERGY FLOW FROM :** none  
**INFORMATION FLOW FROM :** mobility aid station  
**ENERGY FORM :** none

**INFORMATION** : that mobility aid station is clear  
**INFORMATION FORM** : visual  
**ASSUMPTIONS** :

**FUNCTION** : 7.2  
**ACTION** : Return - return mobility aid station to prior passenger condition  
**ACTOR** : Transit Operator  
**INITIAL STATE OF ACTOR** : at mobility aid station ready to return it to other passenger configuration  
**FINAL STATE OF ACTOR** : back in driver cockpit  
**PRECEDING FUNCTION** : 7.2  
**SUCCEEDING FUNCTION** : none  
**PARALLEL FUNCTION** : none  
**MATERIAL FLOW TO** : driver cockpit  
**ENERGY FLOW TO** : none  
**INFORMATION FLOW TO** : other passengers  
**MATERIAL FLOW FROM** : mobility aid station  
**ENERGY FLOW FROM** : none  
**INFORMATION FLOW FROM** : mobility aid station  
**ENERGY FORM** : none  
**INFORMATION** : that seating has returned to other passenger configuration  
**INFORMATION FORM** : visual  
**ASSUMPTIONS** :



**APPENDIX F**  
**ADVISORY COMMITTEE**

---





## APPENDIX F

### ADVISORY COMMITTEE

Marion Bagii  
FRAS Subcommittee Member  
1425 SE 24th, #202  
Portland, OR 97214

Ron Berkshire  
Maintenance Supervisor  
Lane Transit District  
PO Box 7070  
Eugene, OR 97401

Roger Buchanan  
Vice Chair  
3641 NE 72nd  
Portland, OR 97213

Jan Campbell  
Chair  
Metropolitan Human Rel. Comm.  
1120 SW 5th, #520  
Portland, OR 97204-1989

Bob Carroll  
Transit Planner  
Metro  
MS-64, 821 Second Ave  
Seattle, WA 98104-1598

Bruce Chown  
Manager, Accessible Transit  
B.C. Transit  
Vancouver, B.C. V6P 6M2

Garrett Clark  
Oregon State University  
Dept. of Mechanical Engineering  
Corvallis, OR 97331

Patty Fink  
Ass't Planner  
Salem Area Transit  
3140 Del Webb Ave, NE  
Salem, OR 97303

Jim Flemming  
Consultant  
Project ACTION  
1001 Connecticut Ave, NW  
Suite 435  
Washington, DC 20036

Stephen Fosdick  
Special Transp Coord  
ODOT - Public Transportation Division  
131 Transportation Bldg  
Salem, OR 97310

Paul Gamble  
Grants Administrator  
Washington State DOT  
Transportation Building  
Olympia, WA 98504

Philip A. Gebhart  
Manufacturer's Rep  
3107 NW Grant  
Corvallis, OR 97330

Shirley Hall  
6540 NE Alberta  
Portland, OR 97218

Lou Hall  
2600 N Williams, #6  
Portland, OR 97227

Bill Henderson  
Special Projects  
Snohomish Senior Services  
8225 44th Ave West, Suite O  
Mukilteo, WA 98275-2851

Dareld Herling  
Oregon State University  
Dept of Mechanical Engineering  
113 Dearborn Hall  
Corvallis, OR 97331

Wendy Hval  
2127 NE Halsey  
Portland, OR 97232

Ms. Micki Kaplan  
Transit Planner  
Lane Transit District  
PO Box 7070  
Eugene, OR 97401

Sam Learn  
Spinal Cord Association  
825 NE Multnomah, Suite 1075  
Portland, OR 97232

Robert McCowan  
Battelle  
505 King Avenue  
Columbus, OH 43201

David Moffitt  
Risk & Safety Manager / Buck Medical  
TRI-MET  
1630 SE 8th Ave  
Portland, OR 97214

Patricia Nielsen  
Accessibility Planner  
TRI-MET  
4012 SE 17th  
Portland, OR 97202

Wahib Thabet  
Oregon State University  
Dept of Civil Engineering  
100 Merryfield Hall  
Corvallis, OR 97331-4304

Dave Ullman  
Professor  
Oregon State University  
Dept of Mechanical Engineering  
212 Rogers Hall  
Corvallis, OR 97331

Dinah Van Der Hyde  
Special Transp Fund Mgr  
ODOT - Public Transportation Division  
131 Transportation Bldg  
Salem, OR 97310

Frank Whisenhunt  
Maintenance Supervisor  
Lane Transit District  
PO Box 7070  
Eugene, OR 97401

Sterling Williams  
2600 N Williams Ave, #7  
Portland, OR 97227

Kate Zaworski  
Professor  
Oregon State University  
Dept of Civil Engineering  
100 Merryfield Hall  
Corvallis, OR 97331-4304

Joe Zaworski  
Instructor  
Oregon State University  
Dept of Mechanical Engineering  
416 Rogers Hall  
Corvallis, OR 97331

## **NOTICE**

This document is disseminated under the sponsorship of the U.S. Department of Transportation in the interest of information exchange. The United States Government assumes no liability for its contents or use thereof.

The United States Government does not endorse manufacturers or products. Trade names appear in the document only because they are essential to the content of the report.

This report is being distributed through the U.S. Department of Transportation's Technology Sharing Program.

**DOT-T-93-22**

---

**DOT-T-93-22**

***TECHNOLOGY SHARING***

A Program of the U.S. Department of Transportation

---