



US Department
of Transportation

**Federal Transit
Administration**

INNOVATIVE TECHNOLOGY TO IMPROVE TRANSIT MAINTENANCE EFFICIENCY

Final Report

January 1994

**Sponsored by:
U.S. Department of Transportation
Federal Transit Administration**

**Ministry of Transportation, Ontario
Strategic Transportation Research Branch**

**Prepared by:
Transit Development Corporation
I-TIME Task Force**

FTA TECHNICAL ASSISTANCE PROGRAM

NOTICE

This document is disseminated under the sponsorship of the U.S. Department of Transportation and the Ministry of Transportation, Ontario, in the interest of information exchange. The United States Government and the Ontario Government assume no liability for its content or use thereof.

The above mentioned organizations do not endorse products or manufacturers referenced in this document. Trade or manufacturers' names appear herein solely because they are considered essential to the object of this report.

The opinions and conclusions expressed or implied in this report are not necessarily those of the U.S. Government or the Ontario Government.

Although the technologies identified in this report have the potential to improve maintenance efficiency and reduce costs, most of these technologies have not been fully applied or proven in a transit environment. Transit managers should be aware of this limited experience before attempting to apply any of the technologies identified here to their own operations.

1. Report No. FTA-DC-06-0642-94-1	2. Government Accession No.	3. Recipient's Catalog No. UMTRIS /FTA SECTION	
4. Title and Subtitle Innovative Technology to Improve Transit Maintenance Efficiency		5. Report Date January 1994	
		6. Performing Organization Code	
7. Author(s) John J. Schiavone		8. Performing Organization Report No.	
9. Performing Organization Name and Address Transit Development Corporation, Inc. 1201 New York Avenue, N. W., Suite 400 Washington, DC 20005		10. Grant or Project No.	
		11. Contract or Grant No. DC-06-0642	
12. Sponsoring Agency Name and Address U.S. Department of Transportation Federal Transit Administration (FTA) 400 7th Street, SW Washington, DC 20590		13. Type of Report and Period Covered Final Report	
		14. Sponsoring Agency Code TTS-21	
15. Supplementary Notes Equal Financial Support Was Provided by the: Ministry of Transportation (Ontario) Strategic Transportation Research Branch 1201 Wilson Avenue, Downsview, Ontario, Canada, M3M 1J8			
16. Abstract <p>This report presents an analysis of innovative maintenance technologies not commonly used in public transit today. The report reaches out to other industries, as well as to transit itself, to identify the "next generation" of maintenance tools and equipment. Making transit agencies aware of this innovative technology is intended to improve maintenance efficiency and reduce operating costs.</p> <p>Innovative maintenance technologies identified by this study are grouped into four general categories: Low Level Technology, Advanced Technology, Robotics and Condition Monitoring. The search for these technologies involved several activities including surveys, "technology wanted" classified advertisements placed in advanced-technology publications, and visits made to a variety of industrial facilities located in the U.S., Canada and Europe.</p> <p>Valuable assistance and guidance in the preparation of this report was provided by the "Innovative Technology to Improve Transit Maintenance Efficiency Task Force." Known by the acronym "I-TIME," the Task Force was comprised of transit professionals from the U.S. and Canada with extensive experience in maintenance.</p>			
17. Key Words Transit Maintenance Maintenance Technology Rail Systems Bus Systems Robotics Facility Maintenance		18. Document Availability - Available to the public through the National Technical Information Service (NTIS), 5285 Port Royal Road Springfield, Virginia 22161 - telephone 703/487-4650	
19. Security Classif. (of this report) unclassified	20. Security Classif. (of this page) unclassified	21. No. of Pages Part I - 63 Part II - 149	22. Price

METRIC CONVERSION FACTORS

Approximate Conversions to Metric Measures

Symbol	When You Know	Multiply by	To Find	Symbol
LENGTH				
in	inches	2.5	centimeters	cm
ft	feet	30	centimeters	cm
yd	yards	0.9	meters	m
mi	miles	1.6	kilometers	km
AREA				
in ²	square inches	6.5	square centimeters	cm ²
ft ²	square feet	0.93	square meters	m ²
yd ²	square yards	0.8	square meters	m ²
mi ²	square miles	2.6	square kilometers	km ²
	acres	0.4	hectares	ha
MASS (weight)				
oz	ounces	28	grams	g
lb	pounds	0.45	kilograms	kg
	short tons (2000 lb)	0.9	tonnes	t
VOLUME				
tsp	teaspoons	5	milliliters	ml
Tbsp	tablespoons	15	milliliters	ml
fl oz	fluid ounces	30	milliliters	ml
c	cups	0.24	liters	l
pt	pints	0.47	liters	l
qt	quarts	0.95	liters	l
gal	gallons	3.8	liters	l
ft ³	cubic feet	0.03	cubic meters	m ³
yd ³	cubic yards	0.76	cubic meters	m ³
TEMPERATURE (exact)				
°F	Fahrenheit temperature	5/9 (after subtracting 32)	Celsius temperature	°C

*1 in = 2.54 exactly. For other exact conversions and more detailed tables, see NBS Misc. Publ. 286, Units of Weights and Measures, Price \$2.75, SD Catalog No. C13.10.786.



Approximate Conversions from Metric Measures

Symbol	When You Know	Multiply by	To Find	Symbol
LENGTH				
mm	millimeters	0.04	inches	in
cm	centimeters	0.4	inches	in
m	meters	3.3	feet	ft
km	kilometers	0.6	miles	mi
AREA				
cm ²	square centimeters	0.16	square inches	in ²
m ²	square meters	1.2	square yards	yd ²
km ²	square kilometers	0.4	square miles	mi ²
ha	hectares (10,000 m ²)	2.5	acres	
MASS (weight)				
g	grams	0.035	ounces	oz
kg	kilograms	2.2	pounds	lb
t	tonnes (1000 kg)	1.1	short tons	
VOLUME				
ml	milliliters	0.03	fluid ounces	fl oz
l	liters	2.1	pints	pt
l	liters	1.06	quarts	qt
l	liters	0.26	gallons	gal
m ³	cubic meters	35	cubic feet	ft ³
m ³	cubic meters	1.3	cubic yards	yd ³
TEMPERATURE (exact)				
°C	Celsius temperature	9/5 (then add 32)	Fahrenheit temperature	°F

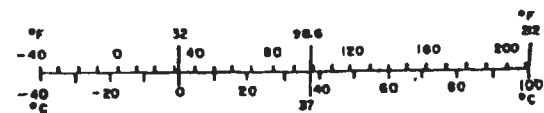

TL
232.2
.S35
1994

18192

AUG 9 '94

ACKNOWLEDGEMENTS

This work was funded by two cooperating organizations: the Federal Transit Administration (FTA) of the U.S. Department of Transportation; and the Ministry of Transportation, Ontario (MTO). The Transit Development Corporation (TDC), a nonprofit educational and research organization affiliated with the American Public Transit Association (APTA), conducted the study.

Valuable assistance and guidance in the preparation of this report was provided by the "Innovative Technology to Improve Transit Maintenance Efficiency Task Force." Known by the acronym "I-TIME," the Task Force was comprised of transit professionals with extensive maintenance experience from the U. S. and Canada representing APTA and the Canadian Urban Transit Association (CUTA).

INNOVATIVE TECHNOLOGY TO IMPROVE MAINTENANCE EFFICIENCY (I-TIME) TASK FORCE

Co-Chairmen:

Robert L. Graham
President
Graham Sales Corporation
6520 Platt Ave. #644
West Hills, CA 91307

Wojtek Wiercienski
Project Research Engineer
Ontario Ministry of Transportation
Strategic Transportation Research Branch
Room 333, Central Building
1201 Wilson Avenue
Downsview, Ontario, CN M3M 1J8

Federal Transit Administration Liaison

Jeffrey G. Mora
Transportation Systems Manager
Federal Transit Administration
TTS-21, Room 6429
400 Seventh Street, S. W.
Washington, DC 20590

Task Force Members

Linda Sue Boehmer
President
LSB Technology
P. O. Box 834
Clairton, PA 15025

James Buckley
Ass't General Manager-Operations
MTA of Maryland
300 West Lexington Street
Baltimore, MD 21201-3415

Joseph Colston
Director-Maintenance
Mississauga Transit
975 Central Parkway West
Mississauga, Ontario, CN L5C 3B1

David Cowan
Manager of Equipment
Toronto Transit Commission
1900 Yonge Street
Toronto, Ontario, CN M4S 1Z2

L. R. Davis
Director-Equipment Engineering
and Advanced Technology
Los Angeles County MTA
900 Lyon Street
Los Angeles, CA 90012

R. W. Mackenzie
Superintendent of Rail Equipment
GO Transit
1120 Finch Avenue West
Toronto, Ontario, CN M3J 3J8

Russell Pentz
Assistant General Manager - Maint.
MTA of Harris County
5700 Eastex Freeway
Houston, TX 77026

Reginald Soubry
Project Engineer
Montreal Urban Community Transit
Corporation
8845 St. Lawrence Blvd.
Montreal, Quebec, CN H2N 1M3

John P. Walsh
Director, Technical Services
Metropolitan Suburban Bus Authority
Mitchell Field Complex
700 Commercial Avenue
Garden City, NY 11530

Transit Development Corporation

Frank J. Cihak
Executive Director

John J. Schiavone
Program Manager

Transit Development Corporation

1201 New York Avenue, N. W.
Washington, DC 20005

TABLE OF CONTENTS

PART I:

Executive Summary	1
Introduction	
Background	3
Methodology/Accomplishments	3
Innovative Maintenance Technologies	
Low Level Technology:	
Equipment to Recycle Coolant, Air Filters and Refrigerant	5
Fluorescent Lamp Recycling	7
Drain Plugs that Isolate Fluids from the Atmosphere	7
High Efficiency Oil and Air Filters	8
Fluorescent Additives to Detect Leaks	8
Shop Mats to Absorb Oil Spills	9
Simplified Procedure to Test Diesel Exhaust Emissions	9
Centralized Vacuum System for Shop Tools and Vehicle Cleaning	10
Portable Cleaning Equipment	11
"Electronic Flagman" System to Warn Track Workers	12
Battery Charging System that Dissolves Lead Sulfate	13
Anti-Graffiti, Anti-Vandalism Protective Laminates	14
Electronic Sensors for Door Controls	16
One- and Two-Dimensional Bar Coding Systems	16
Advanced Technology:	
Lightweight Materials for Vehicle Construction	19
Brake and Suspension Testing Equipment	20
Water-Based Paint and Grease Removal	21
Radar Sensors to Prevent Accidents, Tire Scuffing	22
Modular AC Drive Systems for Electric Vehicles	23
Advanced Vehicle Wiring Systems	24
Contactless Card Applications for Maintenance, Fare Collection	25
Integrating Vehicles with Maintenance Facilities	27
Automated Supply and Maintenance Management System	28
Equipment Reliability, Availability & Maintainability Model	29
Diagnostic Equipment that uses Artificial Intelligence	29
Computer Based Technical Manuals	30
Headset Mounted Workstation Equipment	31

Robotics:	
Robotic Cleaning of Vehicle Under-Carriages	33
Robotic Bus Fueling	35
Robotic Station and Facility Cleaning	36
Other Robotic Applications	37
Condition Monitoring:	
Air Conditioning Monitoring Systems	39
Low Refrigerant Monitoring Sensors	40
Sensors to Monitor LNG Fuel Levels	40
Oil and Air Filtration Monitors	41
Remote Monitoring of Bus Mileage (Electric Hubodometers)	42
Tire Monitors	43
On-Board Vehicle Monitoring/Diagnostic Systems	43
On-Line Vehicle Monitoring/Diagnostics from a Central Location	44
Aftermarket Engine Monitoring and Management Systems	44
Remote Monitoring/Diagnostics of Rail Signaling Equipment	45
Performance Monitoring of Electric Motors (AC or DC)	46
Vibration Analysis of Electric Motors and Mechanical Components	47
Logic Controllers to Monitor Electrical Power Substations	47
Cracked Wheel Detectors for Rail Cars	47
Conclusions and Recommendations	48
References	49

PART II:

Appendices

Appendix A - European Trip Report	A-1
Appendix B - Trip Report to Investigate Electric Motor Monitoring Technology	B-1
Appendix C - Trip Report to Investigate Remote Diagnostics of Rail Signaling and Switching Equipment	C-1
Appendix D - Trip Reports to Investigate Potential Maintenance Technology Transfer from Defense Related Industries	D-1
Appendix E - Trip Report to Investigate Robotic Applications for Facility Cleaning	E-1

PART I

EXECUTIVE SUMMARY

In any maintenance environment, "there is no substitute for the right tool." As transit buses and rail cars become increasingly sophisticated and complex, having the appropriate tools to diagnose and repair these vehicles becomes essential in controlling costs, reducing equipment down time, and improving safety and the environment.

Most transit agencies do not have the time or resources to make a thorough investigation to locate innovative tools and diagnostic equipment used in other industries to improve maintenance efficiency. With this in mind, the Federal Transit Administration (FTA) and the Ministry of Transportation of Ontario (MTO) jointly provided a grant to the Transit Development Corporation (TDC), a nonprofit educational and research organization affiliated with the American Public Transit Association (APTA). The purpose of this grant was to reach out to other industries, as well to transit itself, to identify and document the "next generation" of maintenance technology.

To carry out the goals and objectives of the project, a Task Force was established. The Task Force, comprised of transit professionals from the U.S. and Canada with extensive knowledge in maintenance, investigated several industries to locate Innovative Technology to Improve Transit Maintenance Efficiency. Known by the acronym "I-TIME," the Task Force undertook a variety of activities to accomplish its search.

The report produced by the I-TIME project identifies innovative maintenance technologies that are not commonly used in transit on a wide-scale basis. Some of the technologies identified have been applied in other industries, while others are still in the development stage. Providing information regarding these new technologies permits maintenance personnel to expand their awareness of the innovative tools and equipment that exists beyond their operating environment.

Innovative maintenance technologies identified by this report are grouped into four general categories: Low Level Technology, Advanced Technology, Robotics, and Condition Monitoring. To make it easy to obtain additional information, technologies included in this report are footnoted. A Reference Section, located at the end of Part I of this report, includes the names, addresses, telephone numbers, and FAX numbers of transit systems, manufacturers, suppliers and other organizations applicable to each technology.

This report is comprised of two sections. Part I contains an introduction to the project and summarizes the technologies identified by the Task Force, including reference material in which to obtain additional information. Part II contains the following appendices:

- European Trip Report
- Trip Report to Investigate Electric Motor Monitoring Technology

- Trip Report to Investigate Remote Diagnostics of Rail Signaling and Switching Equipment
- Trip Reports to Investigate Potential Maintenance Technology Transfer from Defense Related Industries
- Trip Report to Investigate Robot Applications for Facility Cleaning

In conducting its search, the I-TIME Task Force collected a substantial amount of background information for each technology identified. In addition to the References and Appendices included in this report, further information may be obtained by contacting APTA's Information Center.

INTRODUCTION

BACKGROUND

Escalating costs for equipment places a greater responsibility on transit agencies to improve the overall efficiency of their maintenance operations. While much of the emphasis is placed on competent management practices, diagnostic and repair equipment play an increasingly important role as well. To identify new technologies that have potential benefits to transit maintenance, the Federal Transit Administration (FTA) and the Ministry of Transportation of Ontario (MTO), jointly provided a grant to the Transit Development Corporation (TDC), a nonprofit educational and research corporation affiliated with the American Public Transit Association (APTA). The purpose of this grant was to identify innovative maintenance technologies from a variety of sources that could be applied to the transit industry.

METHODOLOGY/ACCOMPLISHMENTS

To carry out the goals and objectives of the project, a Task Force was established. The Task Force, comprised of transit professionals from the U.S. and Canada with extensive knowledge in transit maintenance, investigated several industries to locate Innovative Technology to Improve Transit Maintenance Efficiency. Known by the acronym "I-TIME," the Task Force undertook a variety of activities to accomplish its search. Two surveys were sent to transit maintenance personnel, and "technology wanted" classified advertisements were placed in several advanced-technology publications including NASA Tech Briefs, Mechanical Engineering, Society of Automotive Engineers (SAE) Update, Institute of Electrical and Electronics Engineers (IEEE), and the Engineering News Record.

The intent of the surveys was to identify technologies already in use by transit that may not be widely known, while classified ads sought innovative technologies in other industries such as aerospace, automotive, and railroads. Task Force members also traveled to several industrial and governmental facilities in the U.S., Canada, and Europe to identify technologies. National laboratories were contacted and visited to obtain information regarding innovative technologies from the defense and other research industries.

Although the Task Force made an extensive search to locate as many innovative technologies as possible, it does not claim to have identified all possible technologies. To determine if the technologies submitted for consideration were appropriate to the project, the Task Force established specific criteria by which all technologies were evaluated. Technologies identified by the Task Force had to meet the following set of criteria:

- be already proven in other industries,
- be easily transferable to transit,
- have a potentially good return on investment,
- improve working conditions,

- be environmentally favorable, and
- offer opportunities for private sector participation.

Technologies identified by the Task Force were then classified into four categories:

Low Level Technology - equipment and products that are relatively basic in nature and represent a novel approach to improving transit maintenance efficiency.

Advanced Technology - equipment with advanced mechanical and electronic controls that improve safety, increase maintenance efficiency, extend equipment life, improve equipment availability or simplify maintenance tasks.

Robotics - self-guided and self-propelled equipment that perform repetitive maintenance tasks, or are applied in environmentally unpleasant work areas.

Condition Monitoring - onboard and online diagnostic equipment that reveal the condition of either mechanical or electronic equipment to provide early warning of equipment failures, and to establish orderly maintenance intervals.

The Task Force met periodically to evaluate the technologies submitted for consideration, to investigate new technologies, review the overall direction of the project, and to shape the final report. Based upon the findings of the Task Force, automated brake and suspension testing equipment has been installed at The Hamilton Street Railway System in Ontario, and will be installed at the Metropolitan Suburban Bus Authority, Garden City, New York. Robotic cleaning of railcar under-carriages is being investigated by several transit agencies in North America, due in part to the efforts of the I-TIME project. In addition, programs to install robotic bus fueling stations have been influenced by the activities of the I-TIME Task Force. The Task Force also played a role in the developments leading up to the Advanced Technology Transit Bus (ATTB) project, which provides for a completely redesigned and lightweight transit bus using advanced concepts.

LOW LEVEL TECHNOLOGY

EQUIPMENT TO RECYCLE COOLANT, AIR FILTERS AND REFRIGERANT

Coolant:

In many states, coolant (antifreeze) is considered a hazardous material. Regardless of its status, antifreeze must be disposed of in such a way that it will not have a negative impact on the environment. One disposal method involves contracting with a recycling company that will retrieve, recycle, bring the coolant back up to specification, and return it to the transit agency ready for use in their vehicles.

Another method involves the purchase of antifreeze recycling equipment to filter and process the coolant in-house. Basic systems essentially filter the solids suspended in the coolant, while more sophisticated systems actually process the coolant. Systems that process the coolant do so through a distillation process, or through a process that combines filtration with dual bed de-ionization. Recycling equipment using the distillation process separates the coolant into three distinct parts: sludge, water and pure glycol. Foreign particles captured in the form of "sludge" are considered hazardous waste and must be disposed of accordingly. The remaining "water," which contains some amount of glycol, can be reused to top-off the vehicle's cooling system. The pure glycol produced from the coolant distillation process is of sufficient quality to be reused.

Another type of coolant recycling system uses a patented operation that combines filtration with a process known as dual bed de-ionization.¹ In addition to removing contaminants, this process leaves only purified ethylene glycol and de-ionized water. Contaminants are trapped in a paper-filter element for easy disposal. Utilizing a closed-loop system, the portable equipment takes the used antifreeze directly from the vehicle and puts it through an 11-step filtration process. Processed coolant, which meets the general/performance requirements of ASTM D3306, ASTM D4985, and GM 1825-M is then returned to the vehicle.

The portable coolant processing equipment adds all the necessary conditioners back to the coolant to inhibit corrosion, prevent foaming and to neutralize acidic contaminants. The additive package protects all cooling system metals including copper, solder, brass, steel, cast iron and aluminum.

Air Filters:

When an air filter is clogged, air flow becomes restricted, fuel efficiency and horsepower decrease, and diesel exhaust particulates are emitted at higher levels. Frequent replacement of the filter element is one solution to overcoming these problems. However, frequent replacement adds significant purchase and inventory costs to the maintenance

LOW LEVEL TECHNOLOGY

operation. Conventional air filters could also be replaced with high efficiency filters to extend filter life and change intervals. (For additional information see High Efficiency Oil and Air Filters on page 8.)

Although not recommended by manufacturers, another method to extend air filter life involves wet washing. According to tests conducted by a leading air filter manufacturer, however, a cartridge that has been wet-washed for the first time has 20% less capacity than a new one.² Beyond two washings, air filter cartridges average less than 50% of the capacity of a new cartridge. In addition, washed filters are said to have higher initial restriction than new filters. The washing process, which destroys a "precoat" important to its operating efficiency, can cause pleat swelling and an overall reduction in filter efficiency.

To eliminate the detrimental effects associated with frequent filter replacement and wet-washing, dry cleaning equipment has been developed to restore paper-element air filters to 100% efficiency without harming them.³ The four-minute cycle is said to automatically clean filters with a combination of compressed air, a vacuum device, and vibration. The dry cleaning process removes dirt and debris lodged in the filter including exhaust soot that is drawn into air filters. Dry cleaning of paper-element air filters reportedly extends engine life, reduces filter replacement costs, reduces diesel particulate emissions, and decreases the amount of non-biodegradable objects entering landfills.

The dry cleaning system, complete with a light bar inspection device, finishing booth, and waste disposal system is 88" high and weighs about 800 lbs. The cleaning equipment features teflon bearings, stainless steel air cylinders, and bronze bushings. It will clean virtually any paper-element air filter up to 30" high and 18" in diameter.

Air Conditioning Refrigerant:

Refrigerant retrieval and storage systems are required by some states and have been on the market for some time now. However, many automotive units are not designed to handle the requirements of larger-capacity air conditioning (AC) systems commonly used in transit vehicles.

To be effective, refrigerant recycling systems must provide maximum separation of oil, acid, solid particle contaminants, moisture and air. One recycling system pumps the refrigerant liquid or vapor at high velocity and high temperature into a separation chamber as it drops to near zero velocity.⁴ This causes the oil, acid, water and solid-particle contaminants (copper chips, etc.) to drop to the bottom where they can be retrieved along with the maximum amount of retrievable oil.

LOW LEVEL TECHNOLOGY

From the separation chamber, the vapor passes through the compressor and into the air condenser where it is condensed to liquid. It then passes to a chill chamber where it is cooled to 15° to 40° F. This aids in the transfer of the refrigerant to a storage cylinder or back to the air conditioner and also enhances the drying/filtering process. Sub cooled refrigerant is recirculated at a rate of 300-400 pounds per hour for maximum drying.

By using a procedure called "compressor liquid injection" during the vapor removal process, an entire AC system or storage cylinder can be pumped to atmospheric pressure without harming the compressor. This removes virtually all of the refrigerant from the storage containers or the air conditioning system. The refrigerant recovery system also allows maximum air separation, which is easily purged from the system. Other features include an oil sight gauge mounted on the compressor, a float valve safety shut off on the storage/chill chambers to prevent overfilling, and visual check points to monitor the drying process.

FLUORESCENT LAMP RECYCLING

Although not currently regulated by federal law, there are potential environmental hazards associated with fluorescent lamp disposal. A typical fluorescent lamp is comprised of approximately 80% soda-lime glass and 15% metals, primarily aluminum. The balance consists of phosphor powder and inert gases. Environmental problems can result from the addition of two heavy metals, mercury and cadmium. Cadmium is present only in lamps manufactured before 1988, while mercury has always been an integral part of all fluorescent lamps and cannot be eliminated from the manufacturing process.

A company has been formed that recycles fluorescent lamps and produces high-grade mercury as a by-product of the recycling process.⁵ This process involves the separation of glass, metal, and phosphor powder. Metallic mercury contained in the phosphor powder is thermally separated and then purified through distillation. Recycling facilities are located in Allentown, Pennsylvania; Hayward, California; Pine City, Minnesota; and West Melbourne, Florida.

The recycling company arranges for transportation of the fluorescent lamps, and also provides shipping and packaging guidelines. Fees are charged for these services.

DRAIN PLUGS THAT ISOLATE FLUIDS FROM THE ATMOSPHERE

Drain plugs with a dry-break petcock have been developed to remove lubricants directly from the engine, transmission or differential at operating temperature into storage tanks without contacting the atmosphere.⁶ The drain plugs prevent lubricants from spilling on the shop floor or coming in contact with maintenance personnel.

LOW LEVEL TECHNOLOGY

Oil is drained by removing a protective cap located on the drain plug, and attaching a fitting equipped with a flexible drain hose which opens a dry-break valve. Installation of the fitting permits the lubricant to flow into the drain hose and storage container. When the drain hose and fitting are removed, the dry-break valve automatically closes without oil leakage. Made of brass, the drain plugs are available in both imperial and metric sizes. An oil sampling nipple is available as an option.

HIGH EFFICIENCY OIL AND AIR FILTERS

High efficiency oil and air filters are available to reduce component wear and to increase the service life of diesel buses and railway locomotives. These high efficiency filters are intended to reduce maintenance and disposal costs by extending replacement intervals. Reducing disposal costs is a short-term gain, while reducing maintenance costs is a long-term benefit.

High efficiency oil filters for engines and transmissions are available from several manufacturers.⁷ Although each filter differs in internal design and construction, they have patented features to remove contaminants from oil and hydraulic fluid at low-micron levels. The filtration process significantly reduces component wear and protects lubricants from breaking down by absorbing coolant and moisture. Other impurities trapped by these filters include: metal particles and oxides produced from component wear; minerals such as sand introduced by intake air; exhaust soot resulting from combustion blow-by; glycol resulting from internal coolant leaks; and acids produced by lubrication breakdown.

High efficiency air filters are also available to extend maintenance intervals.⁸ These three-dimensional, triple-stage, depth-type media filter elements are treated with a specially-formulated viscous-impingement chemical compound, and can be used as direct replacements for conventional (one-dimensional, single-stage, surface loading-type media) paper filters. Compared to conventional paper filters, the advanced filter design reportedly holds up to eight times the amount of contaminants, while eliminating soot plating, surface loading, salt intrusion, and water-related problems. The filters are guaranteed to last twice as long as the conventional filters they replace.

Filter monitors can be used with both oil and air filters to maximize replacement intervals. (See section on Condition Monitoring for additional information).

FLUORESCENT ADDITIVES TO DETECT LEAKS

The combination of fluorescent additives and ultraviolet (UV) light can be used to detect gasoline, oil, water, coolant and fuel leaks.⁹ This same technology has also been adapted to detect refrigerant leaks in air conditioning systems.

LOW LEVEL TECHNOLOGY

To detect a fluid leak, a fluorescent additive is introduced to the liquid (engine oil, coolant, etc.). Once the fluorescent additive has mixed with the liquid, the suspect area is then traced with a high-intensity UV lamp. All leaks glow brightly when exposed to the UV light, revealing their exact location. The use of fluorescent additives to detect lubricant, fuel and coolant leaks has been successfully used for years in the automotive industry.

The use of UV technology to detect refrigerant leaks is a relatively new process. Fluorescent leak detection will work with all commonly used refrigerants including alternative refrigerants such as R-134a. The process is said to reveal leaks as small as 1/4-ounce-per-year in tubing, solder joints, fittings, coils and valves. It will also detect leaks around moving compressor shafts. Condenser-tube leaks can also be easily identified. The fluorescent detection medium can be mixed with oil, or the refrigerant itself to identify leaks that have eluded conventional testers for years.

A four-step process is used to locate refrigerant leaks. First, a pre-measured and packaged amount of fluorescent additive is used to fill a "mist infuser" installed between the low-pressure gauge and the service port. A valve is slowly opened to circulate the additive throughout the system. An ultraviolet lamp is then used to reveal the precise location of the leaks. Once the leaks are identified and repaired, the fluorescent additive remains in the system to insure that all leaks have been fully identified and repaired.

SHOP MATS TO ABSORB OIL SPILLS

As an alternative to traditional clay granules or "speedy dry," specially designed mats and runners are available to absorb oil spills on garage floors, work benches, storage facilities and other work areas.¹⁰ These mats are used to absorb oil, coolant, transmission fluid, paints, cleaners and other liquids.

After they are saturated, the mats can be easily rolled up for proper disposal or recycling. The 100% non-woven absorbent fabric can be easily cut to fit a variety of areas. Its non-skid and non-penetrating design provides a secure footing for oily feet, and protects floors against oil tracking. Typical applications include shop traffic areas, drum storage areas, vehicle service bays, work benches and other work areas.

SIMPLIFIED PROCEDURE TO TEST DIESEL EXHAUST EMISSIONS

Exhaust emissions from diesel-powered transit buses are increasingly scrutinized as local, state, and federal governments require enforcement of more stringent emission regulations. A simplified "short-test" has been designed for use in a bus garage setting to indicate whether a bus engine meets designed emissions performance levels, or if engine maintenance is required.¹¹ The test procedure, which does not require the use of a chassis

LOW LEVEL TECHNOLOGY

dynamometer, is more accurate than basic smoke opacity tests and has been correlated with the EPA's Federal Test Procedure (FTP).

The test equipment was designed to collect samples of raw exhaust over a short time period for both gaseous and particulate emissions. The samples are collected over two cycles using 30-second sampling intervals, while the bus engine is operated with the brakes locked and the transmission in "Drive." Concentrations of CO, NO_x, and O₂ are determined by using a portable emission analyzer. Particulate concentrations or smoke levels are assessed by reading the light reflectance of the sample filter, which may also be weighed for quantitative determinations. The test procedure was optimized for a 1986 DDC 6V92-TA engine. Additional correlation work to include other engines is dependant on continued industry interest.

To establish a data base in which to form a correlation between the so-called "short-test" procedure and the transient FTP, a 1986 DDC 6V92-TA engine was tested over both procedures using several fuels with varying properties. A correlation between EPA transient cycle emission results and the short-test results was actually established. Short-test measurements were made in a bus maintenance environment at several transit agencies to verify that repeatable results could be obtained. Using the "field" data, the short-test equipment, procedures, and transient prediction models were reviewed and simplified.

The short-test procedure could be a useful, easy and inexpensive tool for bus maintenance personnel to identify and correct engine-related problems that produce excessive levels of emissions. With operational experience, the simplified test procedure should provide insight as to the causes of excessive emissions and the actions required to reduce them.

CENTRALIZED VACUUM SYSTEM FOR SHOP TOOLS AND VEHICLE CLEANING

Centralized vacuum systems that use low volume/high velocity air flow are available to capture dust, dirt and other debris from portable tools, stationary tools, work stations, and to clean vehicle interiors.¹² These products are said to create a dust-free environment, which improves working conditions and extends equipment life.

One set of "spot extraction" products uses a centralized vacuum systems to remove airborne contaminants directly from the work site. Airborne debris is transported through anti-static hoses and steel piping. It is then separated and stored in containers for easy disposal. With hand-held tools such as grinders and sanders, a specially designed casing captures the airborne debris and transports it through flexible suction hoses. The hoses can be "plugged in" to several outlets located throughout the maintenance facility.

LOW LEVEL TECHNOLOGY

With a variety of attachments, the centralized vacuum system can be used to keep several work areas clean. The vacuum system can also be used to transport materials from one location to another. By using a flow valve, suction is provided only to those tools in operation, allowing fewer pumps to serve a greater number of outlets. A cyclone is used to separate heavy debris, while a replaceable filter is used to trap fine dust. Clean air is exhausted to atmosphere or returned directly to the facility to save heating/air conditioning costs.

Spot extraction vacuum equipment can also be used to collect airborne particles from welding stations. The operator can position the flexible tubing and collector above the weld site to remove welding byproducts. Spot extraction equipment can be applied to vehicle interior cleaning functions as well. Major components in this system include a central vacuum generator, cyclone filter, piping (both stationary and flexible), a spray nozzle for dispensing cleaning detergents, and several cleaning attachments. A curb-side receptacle is provided to collect newspapers, bottles and other large objects. Operating controls provide automatic on/off switching, while noise generated from the centralized vacuum equipment is kept below 70 dB(A).

In addition to spot extraction, an integral dust collection system is available for brake lathes. This system is said to remove over 99% of all dust particles generated from brake lining and drum-turning operations. The airborne brake dust is captured by suction casings that surround the cutter bits. Suction casings do not obstruct the operator's vision, and need not be removed when replacing or servicing the cutting bits. Dust particles are stored in a plastic container for easy, dust-free disposal.

PORTABLE CLEANING EQUIPMENT

Cleaning Carts:

As an alternative to fixed cleaning stations, portable carts can be used to clean buses while they are parked.¹³ Cleaning crews use the portable carts, which contain all the necessary cleaning equipment, to travel from one bus to another. Electrical outlets are located throughout the parking area to power lights, vacuum cleaners etc.

Curb-Style Vacuum Receptacles:

Curb-style vacuum receptacles can enhance cleaning operations while buses are parked in storage areas. An underground network of pipes, connected to a centralized vacuum device, is plumbed to each parking area with a receptacle mounted at the curb. Cleaning personnel simply attach a portable, lightweight hose into the receptacles to vacuum bus interiors. (For additional information, see the European Trip Report, Bayonne, France, located in Part II.)

LOW LEVEL TECHNOLOGY

Portable Vacuum Cleaners:

Portable vacuum cleaners are available for vehicle and facility cleaning operations. One type of cleaner is mounted on a small trailer, pickup truck or a rail dolly to clean a variety of transit facilities including parking lots, rail yards and stations.¹⁴ The heavy-duty cleaner requires one operator, and can clean an area with a radius of up to 32 feet when stationary. Litter collected by this portable cleaner is compacted and stored in hygienically-sealed packages for easy disposal. The 1,400-lb. cleaner is fitted with special lifting points, which are suitable for both fork truck and crane attachments.

Another portable device consists of a backpack-type vacuum cleaner, which is carried by cleaning personnel on their backs to clean the interiors of transit vehicles or facilities.¹⁵ The backpack-style vacuum cleaner weighs about eight pounds and features a unique cleaning head to reach behind or under obstructions with as little as 2 inches of clearance. A recessed magnet located in the cleaning head traps metal debris.

Both pieces of equipment can be used to improve the mobility and productivity of cleaning personnel.

Mobile Bus Washing Equipment:

A self-contained and self-propelled rotary washer is available to clean buses while they are parked.¹⁶ The mobile washer is housed in a four-wheel vehicle equipped with water tanks and a large rotating brush that scrubs and rinses buses as it is driven around them. The mobile washer uses about 20 gallons of water and one quart of cleaning solution per bus. A collection basin option allows waste water to be collected, filtered and reused. The mobile washer is relatively compact in size and can be transported from one location to another on a trailer.

"ELECTRONIC FLAGMAN" SYSTEM TO WARN TRACK WORKERS

An "Electronic Flagman" system is available to alert track workers to the dangers of approaching trains.¹⁷ An optional feature takes the warning system one step further by shutting down equipment in use by workers. The portable system uses a series of radio-linked sensors to replace cumbersome, costly and less efficient manual warning systems including flagmen. Remote detector units using doppler radar are placed on either side of a work site. They are linked via UHF radio to a Master Unit. Sirens and flashing lights are activated on the Master Unit when a train approaches, giving up to three minutes of warning depending on the speed of the train and the location of the remote detectors.

LOW LEVEL TECHNOLOGY

The electronic flagman system is designed for use on single line sections of track, although adaptation for multiple line use is being considered. The system is capable of self diagnostics, with fail-safe checks performed on a periodic basis. Both audio and visual warnings are issued in the event of a system failure. The Master Unit logs the time and date of all detection activity for the purpose of safety investigations. If a Remote Station is tampered with, or is tilted more than 40°, an alarm is sounded and sent to the Master Unit.

The Master Unit and Remote Stations are all powered by rechargeable, maintenance-free lead acid gel batteries. Integral battery control circuits ensure that the batteries can be left on charge indefinitely without causing damage.

BATTERY CHARGING SYSTEM THAT DISSOLVES LEAD SULFATE

In a typical lead-acid battery, loss of capacity is often due to the accumulation of lead sulfate solids. This process, commonly known as "sulfation," eventually causes the battery not accept a charge or deliver energy. Once discharged, the energy capacity of the battery can be restored by exciting it with a suitable source of power. However, when conventional DC charging systems are used, the chemical action proceeds imperfectly resulting in a slow degradation of the battery after numerous charge/discharge cycles.

A battery charging system has been developed that uses AC charge and discharge excitation cycles to dissolve lead sulfate crystals that form within batteries.¹⁸ Bursts of high-frequency charging pulses superimposed on a basic 120 Hertz charge/discharge excitation is said to be very effective in dissolving the sulfate crystals present in lead-acid storage batteries. A charge/discharge duty cycle ratio of approximately 80/20 yields significantly faster charging than standard DC charging methods without signs of excessive internal heating or gas formation. The process is called "pulse amplitude conditioning/charging."

The rapid reversal of the electric field inside the battery (primarily during the burst of high energy pulses) in effect "agitates" the molecules of lead sulfate. This agitation causes the solids to dissolve back into the liquid as ions, where they are available for chemical reaction.

Unlike DC charging methods, AC excitation can have a significant effect even on depleted batteries with high internal impedance. While the DC resistance may be high (as a result of both sulfate deposits on the plates and weak electrolyte), the inherent capacitive characteristics of the battery allow the high-frequency AC voltage to do its work and return the lead sulfate salt molecules back into the solution as ions.

LOW LEVEL TECHNOLOGY

At the end of the charging cycle, virtually all of the lead sulfate has been separated into its ionic components, thereby increasing the conductance of the electrolyte. The excitation potential is then able to replenish the plates with lead, leaving the sulfate ions in solution as sulfuric acid, resulting in a fully charged battery. The relative purity of the restored plates and sulfuric acid assures that peak current output (cold cranking amps) is also maximized.

ANTI-GRAFFITI, ANTI-VANDALISM PROTECTIVE LAMINATES

Laminates made from advanced plastic materials are available with unique properties that include resistance to weathering, exceptional mechanical strength, and inertness towards a wide variety of chemicals, solvents and other staining agents.¹⁹ The plastic laminates, available in thicknesses from 0.5 to 2.0 mils, can be permanently bonded to steel, aluminum, vinyl, fabric, and many other substrates to form a strong and durable finish. These laminates can be used in many commercial applications to resist weathering and sun damage, protect interior and exterior surfaces against graffiti and vandalism, and its anti-stick properties also facilitate cleaning. The laminates are available in clear or pigmented forms, and can be painted if necessary.

In transit, the laminates can be applied to a variety of interior panels including trim and seat backs. The strong physical properties of these laminates resists vandalism, while the chemical inertness of the laminate provides an extremely stain-resistant finish. Furthermore, the chemical inertness of the laminate permits the use of solvent-based cleaners to remove strong stains without causing discoloration of the substrate material. Stains caused by soda, coffee, red wine, mustard, chocolate, etc. are easily removed with a damp cloth or mild cleaning agent. Stains caused by ball point and felt pens, lipstick, nicotine, crayon, heel scuffs, etc. require a stronger, solvent-based cleaning agent.

The plastic laminates can also be applied to exterior panels to provide similar protection against graffiti and vandalism. Exterior panels treated with the plastic film are easier to clean, and resists damage caused by environmental pollutants. Decals and other exterior trim pieces normally applied to transit vehicles can be replaced with plastic laminates to withstand numerous washings and to resist fading and discoloration.

Exterior panels located near diesel exhaust outlets are easier to clean when bonded with these laminates. In addition, carbon dust generated from electric train motors is easily dislodged when surfaces are coated with the laminate. Other applications include the interior and exterior of buildings where heavy traffic or severe environments create a cleaning, vandalism or graffiti problem.

LOW LEVEL TECHNOLOGY

The laminates perform well in temperatures ranging from approximately -100°F to 225°F, with intermittent short-term peaking of up to 400°F. When used as an interior or exterior finish, the laminates do not readily burn or support combustion.

Several adhesives, each with different strength characteristics, can be used to bond the laminates directly to the various substrates. Currently, bonding is done by the manufacturer of the product to which the laminates are applied. Bonding of the plastic materials at individual maintenance facilities is also being investigated.

Sacrificial panels made from advanced plastic materials can be used to protect interior glass surfaces from vandalism. These thin-sheet panels of clear plastic can be held in place with retaining tracks to serve as replaceable "barriers" between the passengers and exterior windows. Two-sided tape is also being tested as a way to eliminate the retaining tracks. If successful, the plastic panels can be placed on both sides of the windows. The plastic panels can also protect passengers from splintering glass when a vandal hurls an object at the transit vehicle.

Another method used to protect drivers and passengers from splintering or "spalling" glass involves the use of advanced plastic laminates, which can be bonded directly to glass when it is manufactured.²⁰ When an object impacts a windshield or side window made from standard commercial glass (including so-called "safety glass"), dangerous glass spalling can occur. Spalling is the shower of glass slivers that fly inward from the opposite point of impact. Though the object may not actually penetrate the glass, the glass will be shattered and spalling can occur.

The 3-ply plastic shield, laminated to the interior side of the glass, acts as a strong protective barrier between broken glass and passengers and adds substantial strength to the glass. For example, standard FRA-1 railroad windshields laminated with this plastic laminate can withstand a 24-pound cinder block impact at 40 mph, rather than the 30 mph impact required to pass the FRA-1 test: the United States Federal Railroad Administration standard test for railroad windshield approval. In addition, spalling was totally eliminated when the windshield was laminated with the protective shield.

The 3-ply shield also protects against lacerations. A person that comes in contact with the laminated glass will not be lacerated by the broken glass because the composite material effectively contains the break and prevents the penetration of sharp glass slivers into a person's skin.

The protective laminate can be applied to transportation vehicles, glass doors, floor-to-ceiling windows or in any application where personal safety may be compromised.

LOW LEVEL TECHNOLOGY

ELECTRONIC SENSORS FOR DOOR CONTROLS

The use of electronic passenger sensors is said to eliminate maintenance problems commonly associated with exit step treads, touch bars, and other forms of automatic door controls.²¹ A solid state sensor with modular circuitry is mounted in the vehicle's roof, above the exit-door area. The sensor is used to detect the presence of exiting passengers, and automatically opens the door when the vehicle has come to a complete stop. An exterior-mounted sensor can also be used to prevent the vehicle from moving if a passenger is accidentally trapped between the closing doors.

The patented system uses a form of sonar technology that emits a signal and evaluates the reflections of that signal within its field of vision. The sonar-type sensor examines the entire area surrounding the exit door(s), and has been optimized to distinguish objects such as newspapers from being falsely identified as a small child. Exit doors close immediately after all passengers have left the area, preventing non-paying passengers from entering the vehicle.

The modular sensors are small, easy to install or replace, and can be used in buses and rail vehicles.

ONE- AND TWO-DIMENSIONAL BAR CODING SYSTEMS

Bar coding systems can be used to improve the timeliness and accuracy of inventory control, identify the source of parts and components, track part/component performance, provide current vehicle history information to the shop floor, improve the accuracy and flow of repair orders, and improve management reporting and access to vital information.

Traditional (one-dimensional) bar coding systems store information in a pattern of parallel black and white lines of varying thickness. One-dimensional bar codes can hold up to 20 or 30 characters per inch, enough to identify a part number that can be used to adjust inventory and link that part number directly with a specific vehicle and repair.

In one example of this technology, Repair Orders (ROs) are printed with a serialized bar code.²² Mechanics working on a repair take the RO to the parts counter where the clerk uses a portable laser scanner to "read" the serialized bar code on the RO, as well as the bar code on the parts bin. All parts used to complete a repair are now deleted from inventory and assigned to a specific repair. The mechanic fills in the "time" and "work description" for each repair. When the repair is completed, the mechanic submits the RO to a data clerk who enters the labor and work description information.

LOW LEVEL TECHNOLOGY

In addition to traditional bar codes, a two-dimensional bar coding system has been developed that can store about 100 times more information in the same space.²³ With a two-dimensional bar coding system, the scanner reads the entire surface area rather than tracing a single line across one part of it. By stacking up to 90 one-dimensional bar codes, each just three-hundredths of an inch high, the laser scanner can read each one in quick succession, zigzagging downward until it covers all of the rows.

The 2-D bar code can be used to identify the names of manufacturers/suppliers, when and where the part was installed, and can even provide special instructions for removal and replacement. This is especially useful when special instructions are needed to install a part, or when proper handling techniques are required for hazardous materials. A 2-D bar coding system could also be used to store maintenance history directly on the vehicle or component, and to track warranty repairs to expedite claims and reimbursement.

LOW LEVEL TECHNOLOGY

ADVANCED TECHNOLOGY

LIGHTWEIGHT MATERIALS FOR VEHICLE CONSTRUCTION

Bus and rail car manufactures are exploring the use of lightweight composites in place of steel and other materials to reduce overall vehicle weight. Lighter vehicles have a positive impact on maintenance, resulting in a reduction of brake wear and the use of smaller-sized propulsion and support components. Certain body and structural repairs may also be eliminated because most composite materials do not tend to rust or decay.

Although relatively inexpensive and easy to work with, mild steel and aluminum both have a low strength-to-weight ratios. New materials such as high-strength carbon and stainless steels, carbon fiber composites, and various types of metallic and non-metallic honeycomb sandwiches of equivalent strength have considerably lower weight. Some of the drawbacks traditionally associated with composites include very high per-pound cost, tendency to absorb water, degradation by ultraviolet light, low impact resistance, difficulty in joining with other materials, and a general lack of knowledge by designers concerning the application of these new materials.

Due to extensive research and development efforts directed at overcoming the deficiencies associated with composites, the National Aeronautics and Space Administration (NASA) concluded that composite materials make good choices for transit applications.²⁴ New materials and refined manufacturing techniques have resulted in composite components which are cost competitive with components made from steel or aluminum, especially when life cycle costing is considered. These advances have also resulted in the design of composite structures with improved crashworthiness. Furthermore, past problems associated with flammability and toxicity have been overcome.

The nonconductive properties of composites make their use in electric rail transit systems very attractive since they offer increased resistance to the detrimental effects of ionized air, and offer safety in case of electrical faults. Due to the requirements for electrical insulation/isolation and resistance to harsh environments, use of composites in catenary support structures is considered to be very promising, both in new construction and as retrofit. Bridge and overhead support structures represent another promising area for incorporating composites into urban rail systems due to their reduced weight and erection costs, and longer spans.

The use of composite materials in transit buses has received considerable attention recently to reduce overall vehicle weight. Many standard-sized transit buses exceed rear axle weight limitations when loaded. In addition, the use of alternative fuels such as methanol and natural gas adds weight due to the additional fuel capacities required by these fuels, along with ancillary equipment such as onboard fire suppression systems.

ADVANCED TECHNOLOGY

Two Task Force members visited a German bus manufacturer that had built 25 prototype vehicles constructed from a resin/fiberglass combination with approximately 25% of the matrix comprised of carbon fiber composite.²⁵ Today, 100 of these composite-structure buses operate in several European cities. The 35' X 98"-wide transit bus has a curb weight of only 16,500 pounds, with a seating capacity of 37 passengers and a total capacity of up to 77 passengers. Compared to steel-frame buses, the German-based manufacturer estimates a savings of 39,000 gallons of fuel over the vehicle's service life, which is estimated to be 25 to 30 years due to the non-corrosive characteristics of its composite construction.

Two major FTA-funded bus projects are underway in the U.S. with an emphasis on weight reduction. The Los Angeles County Metropolitan Transportation Authority's Advanced Technology Transit Bus (ATTB) project started with a clean sheet of paper to design a completely new transit bus using aerospace technologies.²⁶ One of the primary objectives of the ATTB project is to produce a 40-foot transit bus with a curb weight of less than 18,000 pounds. The ATTB's primary contractor is recommending that the majority of the bus structure be made of composite materials.²⁷ The floor, ceiling, and firewall are intended to be made from a sandwiched polycarbonate core between .040-inch-thick aluminum face sheets. The face sheets could also be fiber reinforced plastic (FRP) in lieu of aluminum. Access panels could also be made from thin FRP.

Another FTA-funded advanced bus project seeking to reduce overall weight as part of its design goal is headed by the Metropolitan Transit Authority of Harris County, Houston, Texas.²⁸ This project, dubbed the Next Generation Bus (NGB), has design goals similar to the ATTB, except that the NGB will incorporate as many readily-available components as possible. The intent of Houston's NGB project is to produce a near-term version of the next generation transit bus. Their plan essentially is to optimize the German-designed composite bus that already exists.

BRAKE AND SUSPENSION TESTING EQUIPMENT

Several brake testing dynamometers (roller type) are available to provide an objective assessment of brake and suspension components.²⁹ The testing equipment can be used to compliment existing preventive maintenance programs, or as a diagnostic tool to correct brake and suspension related problems. This equipment may also be used to replace on-the-road test drives, which are labor intensive and increase vehicle down-time and maintenance costs. Test drives are normally required following major brake repairs such as relining.

The brake and suspension testing equipment is designed to identify any unusual or excessive wheel bearing or brake drag, brake force, wheel and axle load, and pedal forces.

ADVANCED TECHNOLOGY

It also evaluates pneumatic pressures in the entire braking system. The testing equipment features moveable platforms that can identify excessive free-play in the suspension and steering systems. A side-slip tester also detects incorrect toe adjustments (wheel alignment) to prevent premature tire wear.

Testing results are analyzed and calculated by microprocessors, printed out as reports and sent to a central data bank for maintenance scheduling and future reference.

The brake/suspension testing equipment is easily installed in existing inspections lanes already equipped with a pit. The modular design of this equipment offers step-by-step expansion of the standard test equipment and software to include advanced test functions. Presently available for automotive applications, advanced procedures for heavy-duty vehicles could include the testing of driveline performance, exhaust emissions, headlight alignment and more advanced wheel and suspension alignment.

Brake and suspension testing dynamometers were first observed when two Task Force members visited a maintenance facility in France, operated by Paris Metro (RATP).³⁰ In addition to the brake dynos, the Aubervilliers Bus Garage in Paris contains under-bus washing bays, a waste treatment plant, and an automated parts storage and retrieval system. Additional information pertaining to the European trip and the brake/suspension testing equipment can be found in the European Trip Report located in Part II of this report.

Based upon favorable recommendations made by the Task Force, automated brake and suspension testing equipment has been installed at The Hamilton Street Railway Company in Ontario, and will be installed at the Metropolitan Suburban Bus Authority, Garden City, New York.³¹

WATER-BASED PAINT AND GREASE REMOVAL

Unlike conventional paint and grease strippers that require harsh chemicals, water-based systems conform more easily to environmental and occupational health requirements. A commercial airline has developed an alternative paint removal process that involves high-pressure water jetting.³² This process is also used to degrease jet engine parts, along with the exhaust soot that accumulates on the aircraft's body panels.

The airline had once experimented with a process that used dry ice crystals applied by compressed air. In this process, paint was broken up by the temperature shock of the dry ice at -80° C. The temperature shock allowed the top-coat paint to cool more rapidly than the primer below, causing the paint to shrink and be ground away by the ice crystals.

ADVANCED TECHNOLOGY

Although the dry-ice process was effective, it was rejected because it was a relatively slow and expensive process. The airline then turned to a process involving high-pressure water to remove paint and grease.

The key to the proprietary high-pressure water process developed by the airline is the angle at which water attacks the surface to be cleaned. The system operates at pressures up to 7,250 psi and uses about 10 gallons of water per minute. The high-pressure hose is equipped with a nozzle that rotates at 9,000 rpm to peel away paint. With a nozzle diameter of 1 mm, the jet velocity is calculated to be 1,056 feet-per-second.

In approximately 60% of all paint-stripping applications using high-pressure water, an alcohol-based "softening" agent is first applied to the paint for 2-4 hours depending on the paint's age. The dwell time of the softening process is critical and must be calculated for each individual paint scheme. The intent of the softening process is to leave the primer in place to reduce repainting costs. After the paint has softened, high-pressure water is applied to wash away old paint. Water from the stripping process is collected, cleaned and about 97% of it can be reused.

This water-based stripping process developed for commercial aircraft was designed primarily to remove polyurethane top coats. Removal of epoxy, acrylic or other types of paint is possible, but extensive tests have not been performed.

Another water-based technology used to remove surface material, paint, grease and other coatings involves the use of small ice pellets.³³ This "ice-impact" equipment requires a source of compressed air, water and electrical power (220V, 3-phase) to operate. Upon impact, the ice particles displace surface contaminants with a simple "blast force." As the ice changes from solid to liquid, ice particles deform laterally to exert a shear force which begins as mechanical scrubbing and ends as liquid flushing. This "scrubbing and flushing" action is said to be useful for degreasing, rust removal, paint removal, and other cleaning operations.

RADAR SENSORS TO PREVENT ACCIDENTS, TIRE SCUFFING

A vehicle collision warning system has been developed to give drivers advanced warning when their bus is in danger of impact.³⁴ The high-frequency, radar-based system uses aerospace technology to monitor the speed and distance between vehicles on the road. Using an antenna mounted in the front grille, the system scans the road ahead up to 350 feet. A second antenna, mounted on the right side of the bus, is used to detect objects alongside. Based upon recommended distances adjusted for varying speeds, the equipment alerts drivers to potentially hazardous conditions via warning lights and a tone signal.

ADVANCED TECHNOLOGY

A dashboard-mounted driver control unit houses the warning alarms. A green light is used to inform the driver that road conditions ahead are safe. A yellow light illuminates when the radar system detects an object in its field of vision, while a red light flashes along with a tone signal if the bus is approaching another vehicle or stationary object too quickly. Another driver control unit, mounted near the side-view mirror, is used to warn drivers of vehicles traveling in the "blind spot." Lights flash red if there is a vehicle in the blind spot, and an audible warning sounds if the driver tries to turn while another vehicle is there.

The collision warning system also features an on-board monitoring system to enhance driver safety. All drivers are assigned a personalized electronic "ID" memory or "smart" card that must be inserted into an onboard slot before the bus will start. After the driver has inserted the card, the bus identification number is recorded onto the card, which then tracks and records several driving activities including:

- number of times and duration that the bus exceeded a certain speed,
- maximum speed attained on trip segment,
- total number of alarms issued,
- total elapsed driving time, and
- total miles driven.

An "accident reconstruction feature" is available as an option. This feature is similar to a "black box" used on commercial aircraft, and helps officials to reconstruct the events leading up to an accident. A fleet of 1,250 intercity buses has been equipped with the collision avoidance system.³⁵

Similar technology is available to warn bus drivers when tires are approaching the curb to prevent tire and body damage.³⁶ The system is automatically engaged when the bus is started. It consists of a sensor mounted at curb level on the underside of the bus. The sensor is used to transmit a signal to a display panel mounted on the dashboard. When the bus comes within a preset distance of the curb, a warning lamp and audible signal alert the driver.

MODULAR AC DRIVE SYSTEMS FOR ELECTRIC VEHICLES

Modular AC drive systems for electric vehicles are available to provide a flexible propulsion package that is completely integrated with the vehicle's computer functions and traction motors.³⁷ Compact modules convert the line voltage to voltages suitable for use by three-phase AC traction motors, auxiliary equipment and the battery system. A typical system is comprised of a Propulsion Inverter Module, Auxiliary Inverter Module and a Battery Charger Module. By selecting the appropriate modules, it is possible to power vehicles from a wide range of AC and DC line voltages.

ADVANCED TECHNOLOGY

The components are modular and each is quickly and easily changed to facilitate maintenance and to reduce vehicle down time. Drive equipment is connected to a diagnostic and fault indication system to facilitate troubleshooting and repairs. The system includes several identical propulsion inverters, which permits the vehicle to continue in service at reduced performance. In the workshop, complete inverter modules are easily removed and replaced, and the vehicle is quickly returned to service.

The modular propulsion package has its own air-to-air cooling system. Two air flows, one internal and one external, are separated by a heat exchanger equipped with fans. The propulsion inverter permits electrical braking with the motors being run as generators. Braking energy can be regenerated to the line and consumed by other vehicles. If the line is not receptive, energy is then dissipated into the braking resistors by means of brake choppers.

The modular AC drive package includes a microprocessor based control system, which controls most vehicle functions including the operation of propulsion inverters and motors. Torque and speed of the traction motors are controlled by continuous adjustments of motor voltage and stator frequencies. The Pulse Width Modulation (PWM) technique is employed, and modulation patterns are chosen so that motor losses are minimized.

The propulsion inverter module is designed with built-in protection features. The brake chopper serves as an over-voltage protection for the electronics equipment. The module is also protected against over-current in the output phases, and commutation failures in the gate turn off (GTO) thyristors.

ADVANCED VEHICLE WIRING SYSTEMS

Advanced vehicle wiring systems are being developed to reduce the amount of wiring in vehicles, standardize communication protocol between electronic components, and to establish a priority-based condition monitoring system.³⁸ These "smart vehicle" systems use existing technology adapted from military, aerospace and automotive industries. In addition, these systems work closely with proposed industry standards such as SAE 1708 and SAE 1587 to ensure that electronic components will be easy to interface in the future.

Instead of running individual power and control wires to each electrical consumer on a vehicle, advanced wiring systems use shared power, control and data circuits to connect electrical "modules." Each module is a complete, highly miniaturized computer that uses

ADVANCED TECHNOLOGY

a common communication protocol to integrate with other components. Each module uses a built-in RISC type microprocessor with electronic memory (EEPROM). Modules can be field programmed to perform various functions based on vehicle location and other parameters.

All circuitry (CMOS type) is designed for low power consumption. Modules include power control and regulation so that an unregulated battery source, typical of those found in automotive applications, can be used reliably and without problems. All outputs are electrically isolated (by optical isolation) to prevent damage caused by electronic transients, spikes, noise and even short circuits. Power type outputs are individually fused to protect the module, wiring and control devices.

Communication between modules and other onboard computers is provided by a highly reliable, 2-wire signal network using RS-485. This communication network minimizes wiring requirements and is highly tolerant to electrical noise, both EMI and RFI.

Modules are constructed using surface mount technology circuit boards, and are potted within a strong aluminum enclosure. Due to the design and construction of the modules, they are highly resistant to shock and vibration, dust and dirt, humidity, moisture (including submersion) and wide temperature extremes.

The electronic control systems are also equipped to track and record vehicle information including vehicle component performance, driver performance, and pre-accident trip information. For example, a Driver Seat Alarm can be used to alert the driver if he/she leaves the seat without activating the proper safety controls (e.g. parking brake on a bus). Advanced wiring systems could also perform self diagnostics of electrical, control, and monitoring systems. Self diagnostics can be performed on any electrical vehicle function, including point-to-point monitoring of every output control location to verify proper equipment operation. This information could be used to warn drivers and/or the central maintenance facility if a component has failed or is about to fail. (Refer to the Condition Monitoring section for additional information).

Advanced wiring systems provide an opportunity to integrate all of the electronic devices that are being added to transit vehicles today. This integration has the potential to save labor costs and make all of the electronic switching functions similar on all vehicles regardless of the manufacturer.

CONTACTLESS CARD APPLICATIONS FOR MAINTENANCE, FARE COLLECTION

Paper-driven systems that record and store vehicle, driver and passenger data could be replaced with contactless smart card technology. The credit-card size devices contain

ADVANCED TECHNOLOGY

reprogrammable memory that could be used as a debit, credit, or stored-value card in fare collection or other applications where the storage of data in a compact and portable format is required. Although terminology differs from one application to another, the technology can be classified into two distinct categories: slot-based cards and remote-coupled cards. Slot-based cards require precise physical alignment and insertion of the card into the reading device.³⁹ The contactless technology is sealed within the card itself, containing up to 3K bytes of fully erasable and reprogrammable memory in a single microcomputer. Similar to a portable computer, various directories and files can be created, with each file corresponding to a unique application.

The slot-based cards have no metal contacts and are designed for multiple applications with long life usage requirements. They use simple, straight forward capacitive data transfer techniques, and are powered from the terminal to the card.

Unlike slot-based cards that require insertion into a reading device, remote-coupled cards use a low power, bi-directional radio frequency (RF) technology for data transfer and passive powering.⁴⁰ A proprietary high speed, high endurance read/write memory technology is used for nonvolatile storage of information. The combination of these technologies allows remote-coupled cards to automate the exchange of information between computers and people without requiring physical contact or line of sight positioning. The contactless RF cards could be used for low-value financial transactions and real time distributed data collection. At present, the remote-coupled card contains up to 256 bits of information and can safely transfer data within one foot of the reader. Developments are underway to extend memory up to 2K bytes of information.

Contactless cards could be used in transit for a variety of applications. For fare collection, each card could be programmed to pay for a variety of mass transit uses and parking fees, to adjust fares for special discounts (e.g., for students and senior citizens) and to charge higher or lower fares depending on the time of day.

Contactless card technology could also be used for vehicle identification purposes. Readers placed in strategic locations within the facility could be used to automatically identify a vehicle as it enters, and "flag" those vehicles in need of scheduled maintenance as well as those in need of emergency maintenance. Each vehicle would require a transponder, and a vehicle-specific or driver-specific card depending on the application. As an example, cards could be issued to drivers who would use them as "keys" to start the vehicle. This would prevent unauthorized use of the vehicle and could also serve to keep an accurate log of the vehicle's use. Contactless cards could be linked with other systems onboard the vehicle to monitor the operator's performance. Mechanical performance could also be recorded on cards with any abnormalities noted as part of the post-trip inspection process.

ADVANCED TECHNOLOGY

INTEGRATING VEHICLES WITH MAINTENANCE FACILITIES

Advancements in electronics make it possible to integrate information collected on a vehicle with the transit agency's maintenance facility.⁴¹ The intent of such a system is to obtain correct and timely information, which could then be used to insure equipment availability and safety with minimal expense. For example, condition monitoring systems that report abnormalities in performance, whether it be from vehicles or facility equipment, have the potential to greatly improve maintenance efficiency. If faults are identified before a component actually fails and causes further damage, maintenance can be scheduled accordingly and the risk of in-service failure is reduced. The information generated from a condition monitoring system could then be forwarded to the maintenance facility where provisions could be made to expedite the repair. When vehicles pull in at the end of service, the work required can already be set so that the maintenance crews already have the proper parts on hand.

By electronically linking vehicles with the maintenance facility, all aspects of maintenance including scheduling, inventory control, vehicle movement within the facility, inspections, cleaning functions, diagnostics, and manpower could all be coordinated and optimized. Essential to the success of an integrated system is the collection, dissemination and utilization of accurate information.

In one example of an integrated system, information transfer could occur automatically as a vehicle enters the service lane using infrared, radio, or smart card technology. In addition, an on-board radio could communicate vehicle performance information directly to the facility while the vehicle is in service. Data collected from a bus, for example, could include the following:

- bus number, driver name, miles/hours of operation, etc.,
- fuel, lubricant and coolant consumption,
- tire pressures and condition,
- farebox receipts tallied by coin, paper currency and transfers,
- passenger counts entered in conjunction with each stop and identified by an automatic vehicle location (AVL) system;
- vehicle performance information, and
- driver performance information.

If a mechanical problem is identified, dynamometers built into the inspection lane could verify abnormalities that may exist to driveline, braking, suspension and other vehicle systems. Buses requiring immediate attention, further inspection, or in need of scheduled maintenance could then be sent to an "inactive" storage area.

ADVANCED TECHNOLOGY

If a bus does not require immediate attention, the defect is noted and the bus is advanced to cleaning stations (interior and exterior) either by the operator via a signaling system, or automatically via a vehicle transport system. When cleaning functions are completed, the bus is directed to an "active" storage location.

Buses at each storage location, active or inactive, could be displayed on a vehicle inventory locator screen. Buses could then be easily located within the facility if required for servicing or other needs.

AUTOMATED SUPPLY AND MAINTENANCE MANAGEMENT SYSTEM

Fully automated supply and maintenance management systems taken from the defense industry could be adapted to transit as a means to increase productivity.⁴² The software-driven system provides on-line visibility of all accountable assets, and can be used in centralized or decentralized maintenance operations. It generates consumption analysis and replenishment forecasting reports, and manages all aspects of maintenance.

The supply portion of the system features complete inventory control and management functions. An online parts catalog contains internal, as well as cross-referenced, part numbers. The catalog is also used to define authorized stocking locations and levels for each part. The supply system ensures strict accountability and maintains audit trails. The software used by the system controls all facets of inventory management from requisition through order tracking, receipt and inspection, stocking, and issue.

Of particular value is the system's capability to set stocking levels and reorder points to include an evaluation and forecast of demand, and the setting of safety levels. Special periodic inventory and disposition programs are available. Bar coding capabilities are built into the system. Additional capabilities include tracking of parts, lot traceability, and providing shelf-life information.

The maintenance management portion of the system is integrated with the supply system and provides control and management throughout the repair cycle. The maintenance management software module is specifically designed to enhance productivity by including performance exception reporting, skill center analysis, turn-around-time reporting, and selective job expediting. The software module also allows for the ordering and monitoring of all parts needed to complete the repair. Management reports are available to highlight material deficiencies recognizing the potential for parts transfer among repair jobs, highlighting excess material availability, and forecasting future material requirements.

ADVANCED TECHNOLOGY

EQUIPMENT RELIABILITY, AVAILABILITY & MAINTAINABILITY MODEL

A PC-compatible computer program has been designed to evaluate the reliability, maintainability, availability, and effectiveness of complex electronic, electrical, electrical-mechanical, mechanical, and fluid systems.⁴³ The system uses Markov modeling to determine values for steady-state and time variant cases. It models a system and operational scenario on the basis of several factors including equipment failure rates, equipment mean downtime, and operation and maintenance policy.

Originally developed for public utility companies, the methodology could be used in transit for the following applications:

- conducting qualitative availability assessments of existing or new vehicle design;
- evaluating competing design modification alternatives;
- establishing an optimum maintenance and inspection program; and
- determining appropriate changeout or overhaul frequencies for specific components and systems.

Application of this methodology could provide a greater understanding of the complex factors that keep a vehicle in operation, and the cost savings that result from improved performance. It could also allow transit agencies to compute the probability of any given combination of component failures, and to determine the resultant impact on vehicle availability. With this knowledge, management could switch from preventive to predictive maintenance by implementing a reliability-driven program that is based on a methodology known to have the maximum potential for availability improvement.

DIAGNOSTIC EQUIPMENT THAT USES ARTIFICIAL INTELLIGENCE

Apprentices and "freshman mechanics" learn their skills from training programs, reference material and from veteran maintenance personnel who have accumulated a great deal of information and experience throughout their careers. The transfer of this experience is done formally in classroom settings, and also informally as one mechanic asks the advice of a veteran who is considered an "expert." With the advent of computers and data banks, this wealth of information can be made available to technicians attempting to isolate faults and make repairs. Known as "expert systems," they can actually take the technician through a repair process as an overall approach to improving equipment availability.⁴⁴ These interactive systems provide a wide variety of information and alternatives to technicians trying to solve a particular problem. They use cumulated information on equipment performance, reliability, test times and other data. Information provided to the technician is based upon knowledge collected from past experiences of "experts" and includes detailed

ADVANCED TECHNOLOGY

test procedures, graphics, and step-by-step repair procedures. The system also identifies the tools and supplies needed to execute maintenance and repair tasks.

In addition, the systems allow a technician to hypothesize a cause of failure and generate a test sequence to verify the hypothesis, over-ride tests, delay certain tests and explain the current state of fault isolation. Fault isolation strategies can be optimized on the basis of not only information provided by a pass/fail outcome of tests, but also by such factors as component failure rates, test time or cost, and the technician's own skill level.

Portable equipment is also available as a diagnostic and troubleshooting tool to repair complex systems. The intelligent maintenance aid applies an integrated maintenance system approach to fault-diagnosis. The transportable tool is a model-based system that can be used to provide diagnostic strategies and component repair information.

COMPUTER BASED TECHNICAL MANUALS

Computer-based interactive technical manuals represent an innovative approach to technical documentation.⁴⁵ Early attempts to adopt this technology were made by General Electric for their diesel locomotive training. Electronic tech manuals have the capability to replace paper manuals and are said to reduce information access time, equipment repair time, and storage space requirements. These manuals are updated automatically from one data base. This eliminates having different versions of the same manual.

The system uses an approach known as hypertext/hypermedia to allow the user to rapidly access information in an intuitive rather than linear fashion. Using a "point-and-click" approach, the user navigates through text and graphics using a train-of-thought approach rather than page turning. Table of contents, index search, and bookmark features are also provided to accelerate information retrieval.

The ability to retrieve information quickly, coupled with computer-assisted maintenance procedures, significantly reduces the time necessary to isolate and repair equipment faults. To reduce the amount of storage space needed for technical information, the electronic system places hundreds of thousands of pages of text on compact discs (CD). Interactive training manuals operate on commercial, off-the-shelf hardware.

ADVANCED TECHNOLOGY

HEADSET MOUNTED WORKSTATION EQUIPMENT

A remote, headset-mounted visual display system has been developed for the defense and airline industries to provide reference/training information for technicians while they actually perform maintenance and repair activities.⁴⁶ This wireless personal workstation is linked to a host computer, and consists of a small headset with a full screen display worn directly in front of one eye for personal viewing. The belt-pack radio interface unit is battery powered and allows technicians to work in tight spaces with both hands as they reference electronically displayed service bulletins or repair procedures. A simplified "hands-free" headset with a microphone could also be used by vehicle operators to call out stops required by the Americans with Disabilities Act (ADA).

The display unit for maintenance personnel features a clear, high-quality monochrome image that appears to "float" in space in front of the viewer's eye. The virtual image can be formatted as a 720 X 280 pixel graphics display or a 25-line, 80-column text display. Optional voice recognition input is also available.

ADVANCED TECHNOLOGY

ROBOTICS

ROBOTIC CLEANING OF RAIL CAR UNDERCARRIAGES

Manual cleaning of rail car undercarriages creates a potentially hazardous environment for workers due to the dust, dirt and other debris that becomes airborne when compressed air is used for cleaning. The use of robots equipped with high-pressure air and vacuum collection equipment to perform cleaning tasks removes maintenance personnel from this harsh, dirty, and potentially dangerous environment. In addition, the use of robots for undercar cleaning improves the reliability and safety of train service by keeping electrical components free of dirt which greatly reduces the potential for fire.

Robots can also be applied to perform undercar degreasing operations using high pressure water and detergents to remove grease and heavy dirt build-up. In both cleaning applications, the robots move along a dedicated track system from one position to another. These robots can be programmed to clean a variety of rail cars once the car type has been identified and the starting position established. A person familiar with the cleaning operation is used to "teach" the robot the necessary maneuvers required for the cleaning function. This information is then stored in memory and the robot repeats the task either by point-to-point or continuous path programming. Vision systems can also be used to help guide the robot by providing visual references. Collision sensors mounted in the robot arms can be used to detect and avoid obstructions.

In 1986, a report was prepared by the Long Island Rail Road (LIRR) for the Urban Mass Transit Administration.⁴⁷ This report concluded that robots can be used in undercar cleaning applications to remove maintenance workers from potentially hazardous and environmentally undesirable working conditions. Criteria established by the LIRR called for an electric-powered robot to be small enough to fit under a 6'4" high platform. The robotic system was proposed as part of a new maintenance facility. The proposal consisted of two robots located on opposite sides of a car, with each robot moving along 170 feet of track running parallel along the entire length of two mated cars. A simulation was prepared, which showed no apparent problems or interferences for either robot in reaching or accessing the components located in the car's undercarriage. Testing was also conducted on a limited basis with success.

The manipulative capabilities of the robot had to be capable of reaching difficult access areas to the centerline of the car, and had to operate on simple or "user friendly" programming.

The Montreal Transit System uses a simple robotic system at its Beaugrand and Youville facilities.⁴⁸ These applications use large volumes of air to clean the car's bogie areas. At the Youville facility, robots are used to clean undercarriages in addition to the bogie areas. In Montreal's case, the cleaning operation consists of removing the tire-wear

ROBOTICS

rubber dust, carbon deposits and other foreign (and potentially flammable) particles from the components and structures located under the railcar. The robotic cleaning system in Montreal is not designed for degreasing because the entire rail system is located underground and the need for washing occurs infrequently.

Montreal's robotic cleaning system consists of single, all-electric industrial (welding-style) robot mounted on a track installed in a pit under the rail car. The rail car is driven into the cleaning area slowly, allowing the system to clean the undercarriage. The articulated robot performs a single-axis search routine to accurately locate its cleaning target, and then uses a dual spray nozzle (straight and 90°) to perform its cleaning operations.

A feasibility study was also undertaken by the Ministry of Transportation of Ontario (MTO) to examine the potential application of robots to clean the undercarriages of Toronto Transit Commission (TTC) subway cars at its Wilson facility.⁴⁹ The TTC currently uses compressed air to manually remove dry dust and dirt from electrical components. Although workers wear protective equipment and breathing apparatus, the dust collection system is less than ideal, with a good portion of the dirt spreading throughout the facility and coming into contact with unprotected workers. The TTC also performs a manual degreasing operation in which workers spray a hot water and soap solution at the bogies, couplers, and other components to remove grease and dirt. The job is very unpleasant and the quality of work is difficult to control.

Under the MTO proposal, a robotic cleaning system for the TTC would consist of three independently controlled industrial finishing robots. A master control system would allow the operator to remotely select and start the automatic operation of the robots. Each robot would be mounted on a 200-foot linear track with additional rotary and linear mechanisms to improve reach and operational capabilities. One robot would operate under the car between the tracks, while the others would be at each side of the car. The compact size of robots would allow them to perform in restrictive work areas, and to execute all of the complicated movements and manipulations needed to reach difficult access areas.

Prior to the cleaning, an operator would remove certain component covers to allow robot access to these areas. Special safety features would be built into the system to ensure that the worker and the robot do not share the same workspace at the same time. The operator would be safely located in a control room on the platform above, observing the cleaning via closed circuit television cameras. The operator would also input the vehicle number to allow the master controller to select the correct cleaning program, and would indicate whether the car is to be blowdown or degreased.

The MTO study, which included the testing of robots, concluded that it is technically, logistically, and economically feasible to implement and operate an automated system

ROBOTICS

incorporating industrial robots for cleaning TTC rail cars at the Wilson facility in Toronto. The proposal is still under consideration.

Interest concerning the robotic cleaning of rail cars was expanded during the I-TIME field trip to Europe. Task Force members visited an undercar robotic cleaning system in use at the Alberg subway maintenance facility in Vienna, Austria.⁵⁰ The facility services 225 cars with undercar cleaning scheduled monthly for each car. The cleaning facility consists of a cleaning bay equipped with robotic cleaners, control room, and dust collection system. The cleaning bay contains an elevated track and the cars are pushed to the end stop, thus solving the positioning problem. Once the side covers have been removed manually the robotic cleaning is done with compressed air only, which is delivered by four identical robots.

Each robot travels on its own track along approximately half a car length, and is equipped with a multiple air nozzle tool and dust collection (vacuum) tube. In addition, the entire building has a recirculation system that introduces clean air at the ceiling level while collecting dirty air at floor level. The robot's operation is staggered in time to maximize the use of the compressor systems. The cleaning of one car takes about 20 minutes to complete. (For additional information refer to the European Trip Report located in Part II).

Robotic undercar cleaning has received interest from several transit systems contemplating its installation as a way to improve working conditions and to improve the overall quality of the cleaning operation.⁵¹

ROBOTIC BUS FUELING

Robots can be programmed to perform bus fueling operations, especially with alternative fuels that present increased safety hazards when compared to diesel. A diesel fueling operation observed in Bayonne, France, uses a robot with a fueling nozzle assembly that moves on a track, locates the fueling inlet and automatically fuels the bus.⁵² The entire fueling operation requires about 20 seconds to complete.

Sensors located at each end of the fueling island are used to detect the presence of a bus. There is an additional magnetic sensor in the nozzle assembly which detects the fuel inlet. The robot carries the fuel line from the pump along an overhead track system. The nozzle assembly then moves vertically towards the bus to dispense the fuel. (For additional information refer to the European Trip Report located in Part II).

Based upon the information provided by the I-TIME visit to France, Houston Metro began to investigate the feasibility of applying a robotic application to their LNG fueling facility.⁵³ With assistance from a national laboratory, Houston is studying the concept in

ROBOTICS

hopes of improving the safety and efficiency of all fueling operations including diesel, CNG, methanol and other alternative fuels.⁵⁴ Although the robotic action of getting the fuel nozzle to the inlet on the bus is relatively straight forward, the cryogenic nature of LNG provides significant challenges to the overall development effort.

Providing an air-tight seal at the dispensing nozzle connection to the vehicle is absolutely essential to the robotic application of LNG fueling. Since the delivery line to the vehicle must be flexible, supplying adequate insulation to the nozzle will be difficult. Without sufficient insulation and a fuel temperature of about -260° F, moisture in the air will turn to ice on the nozzle making it very difficult to achieve an adequate seal. Flowing a gas such as nitrogen or de-humidified air around the nozzle to keep it warm may be one solution to the freezing problem. Even when the freezing problem is solved, finding a sealing material that can withstand the extreme cold temperatures will be a challenge.

ROBOTIC STATION AND FACILITY CLEANING

In Paris, one robotic application is in use for cleaning various facilities including railway stations. In an effort to improve efficiency, the transit agency in Paris decided that robots would be used to clean their extensive subway network.⁵⁵ Consequently, they contracted with a private organization to handle cleaning functions, as well as to develop human-assisted robotic cleaning equipment to reduce their dependency on manual labor. A consortium was formed in 1985, with the intent of improving the quality and productivity of cleaning the metro system.

The consortium produced automated facility-cleaning equipment in two configurations. One is manually guided by cleaning personnel, while the other is programmed to operate automatically. Both are electrically-powered using track-drive platforms to maneuver. They carry scrubbing and vacuum modules, along with a collection of tools normally used by cleaning personnel such as a hand-held vacuum and a high-pressure washer.

Staircases are negotiated with the track-drive propulsion system, and the equipment can be transported from station to station by cleaning personnel via trains. The robotic cleaners are basically floor sweepers with rotating brushes that sweep the debris toward the center where it is vacuumed into a filter-equipped dust bag. They also feature onboard fire suppression equipment.

The other type of cleaning robot used in Paris is designed to operate in autonomous or manual modes. When using autonomous navigation, the area to be cleaned is "mapped" into the robot's memory with the help of a gyro. Absolute position references are

ROBOTICS

periodically obtained from magnetic "targets" imbedded in the floor. In the manual mode, the robot is moved between work stations using a joystick.

In addition, robots were tested in Paris to clean the floors of subway cars. The prototype robot is small enough to fit under the seat and is hand carried from car to car. Designed to work automatically, the floor layout of the car is programmed into the robot's memory. It is also equipped with ultrasonic detectors for positioning and object avoidance. Cleaning is accomplished with two rotating scrubbing brushes and suction.

Another prototype robotic system is used to clean walls and ceilings throughout the rail system in Paris. This equipment is designed to travel on the existing rail system, and can be automatically "lifted" onto the rail platform to permit the passage of trains. It features a large, remotely-controlled arm fitted with specially designed brushes and a water recovery system. (For additional information on robotic applications in Europe refer to the European Trip Report located in Part II).

A manufacturer of robotic floor cleaning equipment, intended primarily for building maintenance, was also identified through the I-TIME technology search.⁵⁶ The U.S. manufacturer offers 50 different floor and carpet cleaning machines. Of particular interest to this report was their robotic floor scrubber. With up to five hours of run time, the robotic scrubber can clean 80,000 square feet of flooring on a single electrical charge.

The robotic scrubber uses a single on-board computer to control its navigation and object-avoidance systems. To navigate, it transmits an invisible light beam to wall-mounted bar codes, which it uses as targets. Navigation information is captured and decoded, allowing the robot to calculate its position. The robot has a 360° field of vision, and can read targets up to 600 feet away. Using the targets as references, the robot is programmed to clean a defined area. It begins at the starting point of a defined area and continues its cleaning operation until reaching the finishing point. The robot is capable of moving from one cleaning location to another without operator assistance.

To avoid objects in its path, 23 sensors are placed around the scrubber's perimeter. Once it detects an object, the robot stops, plots a course around it, and then resumes its preprogrammed cleaning schedule. (For additional information refer to the Robotic Trip Report located in Part II).

ROBOTICS

OTHER ROBOTIC APPLICATIONS

There are several other areas where the use of robots could offer significant benefits. Some of these applications include:

- cleaning engines/transmissions
- cleaning other mechanical components
- vaulting bus fareboxes

CONDITION MONITORING

The basic goal of a preventive maintenance (PM) program is to preserve the operational integrity of equipment by performing routine repair and servicing operations in the most cost effective manner possible. Performing a maintenance activity before it is needed represents a waste of resources, while waiting too long can result in catastrophic failure, service interruptions and costly repairs. Therefore, finding the correct interval at which to schedule a maintenance activity is absolutely essential to a successful PM program.

Traditionally, maintenance managers have established service intervals based on a number of factors including manufacturer's recommendations, climate, operating environment, their own judgement and past experience. In too many cases, maintenance is performed only after a component has actually failed.

Diagnostic tools that monitor the condition of mechanical and electrical equipment have the potential to improve maintenance scheduling. By obtaining early warnings of equipment deterioration and malfunctions, maintenance personnel can schedule service and repair functions before failures actually occur. As a result, labor and parts are used more efficiently, and costly downtime caused by catastrophic failure is prevented.

AIR CONDITIONING MONITORING SYSTEMS

An onboard data management system is available to monitor interior temperatures and equipment performance of vehicle air conditioning systems.⁵⁷ The microprocessor-based information gathering and storage system is used to detect operating inefficiencies before costly and major damage occurs. Sensors are used to monitor a variety of conditions including interior temperature readings at different locations throughout the vehicle. Sensors can also be used to monitor and record several other conditions such as: return air temperature, discharge air temperature, overheating conditions at the discharge side of the compressor, oil level, and if a compartment door has been left open.

Acceptable performance levels can be pre-set for each sensor. Should conditions exceed the predetermined levels, various alarms can be used to warn the driver such as a blinking light and a fault symbol which appear on the display screen. Built-in diagnostics allow the driver to radio pertinent information back to the maintenance shop for corrective action.

Software made available with the system allows stored data to be extracted and downloaded to a PC for further evaluation by maintenance personnel. Data can be arranged in table and/or graph form, and is displayed on a PC screen or printed out in hard copy form. A plug-in port allows data to be extracted directly via a hand-held device for immediate analysis of air conditioning performance.

CONDITION MONITORING

Once data is accumulated and stored it can not be tampered with, erased or lost. Data is stored indefinitely in a non-volatile memory, requiring no power supply. The data remains secure even if the air conditioning unit shuts down. An internal battery with a ten year life expectancy keeps the internal clock operating, even if the unit is not.

LOW-REFRIGERANT MONITORING SENSORS

The loss of refrigerant in an air conditioning system adds to the earth's environmental problems, and results in reliability and performance problems that include premature compressor failures and insufficient cooling. Various methods of measuring the amount of refrigerant present in air conditioning systems have been developed. These methods, however, are said to be insufficient in detecting a refrigerant loss early enough to prevent compressor failure and insufficient cooling.⁵⁸

An accurate way to measure the amount of refrigerant in an air conditioning system is to measure the liquid-gas flow ratio in the liquid line. To accurately measure the liquid-gas flow ratio, a mechanical sensor for fluids was developed and applied to a refrigerant monitoring system. This system detects the amount of refrigerant when it falls to 60% of the regular level.⁵⁹

The liquid-gas flow ratio is determined by separating the two-phase fluid into its gas and liquid components, and by measuring them individually. By directing the refrigerant into a bypass area characterized by a very low flow rate, the gas-liquid separation occurs in a small space. Since the flow rate is directly proportional to the area under the same difference of pressures, the flow ratio is determined from the ratio between the areas of the orifices through which the separated gas and liquid flow in parallel.

The sensor can be applied to a monitoring system that shuts down the air conditioner when the refrigerant falls to 60% of the regular level, preventing catastrophic failures and additional refrigerant loss. It can be used with both CFC-based refrigerants, as well as non-CFC refrigerants such as HFC-134a.

SENSORS TO MONITOR LNG FUEL LEVELS

Monitoring the fuel levels in LNG tanks is important to ensure that tank capacity is maximized. A sufficient amount of space is required in the tank to allow for the expansion of the fuel as it converts to a gas. Two methods are used to measure the fuel level of double-insulated cryogenic LNG tanks.⁶⁰ One method involves the use of a differential pressure method for measuring LNG fuel levels. A pressure sensor at the bottom of the tank samples the hydrostatic (liquid head) pressure of the LNG, while another sensor samples gas pressure at the top of the tank. The differential pressure is converted

CONDITION MONITORING

electronically and displayed on an indicator panel, which is equipped with a series of lamps. The lamps illuminate in sequence to denote the level of LNG in the tank.

Another level sensing device for LNG consists of a 3/8" o.d. cylindrical capacitor constructed of stainless steel, which allows the cryogenic fluid to become the dielectric between the concentric capacitor plates. The instrument measures the sensor capacitance, which is directly proportional to the percentage of the sensor immersed in the liquid. A "High Level Warning" relay contact is used to illuminate an indicator lamp located near the fill location of the bus.

With both methods, the electronic display panel used to indicate tank levels can be mounted close to the LNG filling nozzle for convenient viewing. Before filling the tank, the person fueling the bus simply "plugs" a cord from the display panel into a receptacle located near the fuel port on the bus to monitor LNG fuel levels. A display panel can also be mounted in the driver's area if needed.

Development work is underway to produce LNG fuel-level sensors that would not penetrate container walls with physical connections.⁶¹ One promising technique involves the use of strain gauges mounted in the tank mounts that would measure the weight of the tank and calculate fuel levels. Additional work is required to determine if this is a cost effective solution, and one that can be repeated with accuracy. Another possible method to detect LNG fuel levels in tanks involves the application of ultrasonic sensor technology.

OIL AND AIR FILTRATION MONITORS

Monitors are available to sense the increasing pressure drop across the oil filter element as the filter traps contamination and engine wear particles.⁶² These monitors are used for both engine and transmission filtration. A warning lamp, mounted either in engine compartment or in the driver's area, illuminates when approximately 90% of the element life is consumed. A green lamp is illuminated when the filters are working normally. When a filter becomes saturated, a red lamp is illuminated to signal that a filter change is required.

This monitoring device ensures that filters are serviced only when necessary. If a component failure is in progress, the warning lamp will also provide an early indication of abnormally rapid contaminant buildup.

Similar monitors are also available to detect when air filters need replacement. One in particular uses graduated readings to denote the amount of service life remaining, ensuring 100% efficiency from every filter.⁶³ As a result, air filters are changed only when needed, thus avoiding unnecessary labor, downtime costs, and potential damage from lack of filter servicing.

CONDITION MONITORING

These monitors are typically used in conjunction with high efficiency filtration systems to extend filter life and change intervals. (For additional information see the Low Level Technology section of this report).

REMOTE MONITORING OF BUS MILEAGE (ELECTRONIC HUBODOMETERS)

An electronic hubodometer automatically counts and records each revolution of a bus wheel and uses this data, along with the diameter of the tire, to electronically calculate the distance the bus has traveled.⁶⁴ This information is then transmitted to either a stationary receiver or a portable hand-held receiver. When interrogated, the electronic hubodometer transmits the following information: preprogrammed vehicle identification number, the accumulated mileage of the vehicle, and coded data, including information on the status of the battery powering the unit.

The data collected can be downloaded directly to a receiving device to generate accurate mileage reports. It can also be combined with a fluid management system to provide accurate mileage information on fuel and oil consumption.

One option is to use a fixed-mount receiver, which is installed along side the curb of the service lane. As the vehicle stops for servicing, data from electronic hubodometer is automatically transmitted to the receiver, providing a hands-free collection of information. The receiver can retrieve data transmitted by the electronic hubodometer within a ten foot distance along the curb. In most applications a single receiver is sufficient for buses up to 40 feet in length. A second receiver is recommended for articulated buses.

Another option involves a mobile receiver and data storage unit. The hand-held device is used to transfer, display, and store the bus number and mileage information to a PC directly or via modem. The hand-held device is battery powered and features a four-line LCD display. The unit can typically store over 1,300 records. A special message is displayed when the batteries become low.

The electronic hubodometer and data collection/storage system is designed around a low-power 8 bit RISC single chip micro-controller and uses the most recent advances in digital signal processing. A SAW (Signal Acoustic Wave) stabilized Radio Frequency transmitter is used for reliable data transfer. Digital Pulse Modulation (DPM) eliminates electrical noise, while Data Averaging and checksum techniques prevent corruption of collected data. Each electronic hubodometer is powered by two factory-installed lithium batteries. Low power CMOS technology and power saving algorithms provide an expected battery life of five years or more. A Programming Kit is used to initialize the system and to enter or change information such as vehicle number or tire size.

CONDITION MONITORING

TIRE MONITORS

Tire manufacturers have adopted technology that uses built-in sensors and receivers to obtain information on tire identification and operating conditions.⁶⁵ Computer chips embedded into these so-called "smart tires" are capable of storing a variety of information including when and where the tire was manufactured, and the tread originally fitted with the tire. Integrated with the chip is a radio transponder that broadcasts the data to a receiver unit. The receiver or "reader" unit can be installed into the service line, or used as a portable hand-held device.

Data transmitted from the tire is then stored in the central maintenance computer, where various reports can be produced. Maintenance managers can use the information to decide when to retread or replace a tire. The chips can also have sensors to monitor air pressures, temperatures and other operating conditions.

Another tire system monitors air pressure only.⁶⁶ Wheel sensors (electronic valve caps) located on each wheel contain a pressure sensor and micro-chip transmitter that send a radio signal to a central display unit located in the driver's compartment. The wheel sensors continuously monitor the pressure at each tire and warn the driver via wireless remote transmission when tire pressure falls below its normal operating level. An LED instrument display identifies which tire is losing air pressure.

The complete system consists of an instrument display monitor that fits into a standard 2" diameter instrument panel cutout, a small receiver module that is mounted under the instrument panel, a 5" antenna installed under the vehicle and a set of wheel sensors. The wheel sensors weigh about 1/2 ounce each and are pre-set to trigger an alarm when any tire loses approximately 10 pounds of air pressure. The wheel sensors are pre-set by the manufacturer and must be ordered for the appropriate recommended tire pressure. Installation does not require the use of hoses or wires to the wheels, and is accomplished without special tools in about one hour.

A portable hand-held monitor also allows maintenance personnel to check for low tire pressures by simply walking around the bus during refueling operations.

ON-BOARD VEHICLE MONITORING/DIAGNOSTIC SYSTEMS

As described in the Advanced Technology section of this report, advanced wiring systems have the potential to reduce the amount of vehicle wiring and vehicle weight, and to standardize the communication between electronic components. In addition, advanced wiring systems along with the appropriate sensors and software have the capability to perform onboard monitoring and self diagnostic tests of key vehicle components.⁶⁷ Parameters are established for the performance of each component or system, and warning

CONDITION MONITORING

signals are activated once these parameters are exceeded. The self diagnostics allow malfunctioning equipment, or even marginally functioning equipment which may fail shortly, to be identified. Intermittent electrical problems caused by loose or poor connections are also identified.

On-board condition monitoring systems can prevent catastrophic failures, which may lead to secondary failures as well. Benefits include a reduction in equipment downtime and reduced repair costs. In addition, personnel with lower skill and training levels can be used to make repairs since the most difficult task of troubleshooting has already been accomplished.

Information obtained from the system can be provided to the driver, transmitted to roadside receivers and/or retained for end-of-the-day transmission to a central maintenance operation.

ON-LINE VEHICLE MONITORING/DIAGNOSTICS FROM A CENTRAL LOCATION

On-line monitoring of vehicle operating parameters from a central location can detect developing failures and abnormalities in equipment before resulting in catastrophic failure.⁶⁸ This capability also allows for efficient scheduling of corrective maintenance actions through early detection. In many cases, accurate fault detection can only be obtained during actual operating conditions. If faults are detected and isolated before a vehicle arrives at a maintenance facility, the appropriate service or repair can be scheduled. This eliminates test drives and related diagnostic procedures to locate faults.

In Bayonne, France, a simplified on-line vehicle performance monitoring system is used in conjunction with an Automatic Vehicle Location and Control (AVLC) system. Each bus is equipped with a digital radio, an electronic data storage device, and a driver's display. The memory used in the system is large enough to accommodate an entire fleet's schedule, which is downloaded via radio when required. In addition to providing information regarding schedule adherence, the system provides on-line performance information including oil pressure, water temperature and other vehicle conditions. (For additional information refer to the European Trip Report in Part II.)

AFTERMARKET ENGINE MONITORING AND MANAGEMENT SYSTEMS

In addition to sophisticated engine monitoring and management systems that are built into the components by the manufacturer, aftermarket systems that are more basic in nature are also available.⁶⁹ These microprocessor-based systems are compatible with several engine types, and monitor vital conditions such as engine speed, coolant level, coolant temperature, oil temperature and oil pressure. Once set parameters are exceeded, the appropriate warning is sent to a display panel located near the driver. The equipment can be

CONDITION MONITORING

programmed to shut down vehicle systems, including the engine itself, to prevent further damage. The operator can manually override the shut-down feature for safety purposes.

This aftermarket monitoring system is designed to operate on non-electronic controlled engines, or it can be integrated with electronically controlled engines. It is fully automatic/passive, and requires no driver involvement. It can be used to provide advanced warning of component failures, reduce excessive idle time, or to schedule maintenance activities.

REMOTE MONITORING/DIAGNOSTICS OF RAIL SIGNALING EQUIPMENT

A remote monitoring and diagnostic system has been developed for use with processor-based rail switching and signaling equipment.⁷⁰ Proprietary software, designed to operate on a PC, continuously monitors all signaling and switching locations throughout a rail system from a central location. When a fault is detected, the monitoring system automatically diagnoses the problem to indicate the fault or field condition and displays this information to the operator. The entire operation is done in the convenience of an office environment.

The monitoring and diagnostic system locates the fault, displays the corrective action in "simple English" on the PC monitor, and actually provides the replacement part number(s) for the circuit board(s) at fault. A technician is dispatched with the correct part(s) in hand, thus minimizing system downtime.

Software used to operate the system permits historical logging of data so the events leading up to a particular failure can be later analyzed for possible trends. Additional comments can be added to each fault in an effort to provide as much information as possible to protect against future failures. The system shows information in the form of box-like "windows" that appear on the monitor screen. The windows provide a clear, overall picture of the system as opposed to the more traditional methods that require entry of special keyboard commands to give instructions.

The system also provides access to on-line help "menus" to assist in using the features of the fault detection and diagnostic system. Menus are available while the program is operating by selecting the "HELP" command either as a menu selection or as a push-button in the window of interest. In addition to operating the system from an office-based computer, the system software will also run on many laptop computers to permit the same level of advanced diagnostics capability in a portable unit suitable for local on-site field connection. The laptop computer is especially useful during field checkouts and verification of new control system installations.

CONDITION MONITORING

PERFORMANCE MONITORING OF ELECTRIC MOTORS (AC OR DC)

The overall condition of electric motors, both AC and DC, depends primarily on two factors, the mechanical condition of the various components and the resultant electrical fields that are produced. Condition monitoring equipment has been developed that allows the user to evaluate these factors with non-intrusive methods to determine if a malfunction exists and to establish an orderly schedule for preventive maintenance activities.⁷¹ The methods used to monitor electric motors include a combination of mechanical vibration spectrum analysis and motor current spectrum analysis. This equipment can be applied to test a variety of electric motors including those used in rail vehicles, buses and facilities (escalators, elevators, ventilation fans, etc.).

Motor Current Signature Analysis (MCSA) was developed as a means for determining the effects of aging and service wear, specifically on motor-operated valves, but is applicable to a broad range of electric motor driven rotating machinery. The system consists of a data collector, a condition monitoring software package, and a signal conditioner. The equipment is capable of providing on-line, non-intrusive monitoring of electric motors via a simply connection to one of the motor's lead wires. Motor signatures, obtained in both time and frequency domains, provide equipment condition indicators that are then trended over time to provide early indication of degradation.

Testing of AC motors must be performed at or near full load, thus requiring the use of a dynamometer or in-service testing procedures. Test results accumulated to date appear to be accurate enough to analyze the motor's slip as a way to identify damaged rotor bars and high resistance joints within the motor. It has also been noted that the results of classical vibration data and MCSA are very similar, with MCSA providing the rotor speed and slip along with other indicators of motor performance. Since slip is purely an electrical phenomenon, it is not detected by vibration sensing means.

The testing of DC motors does not require it to be under load. Although current signature tests performed on DC motors have revealed breaks in the insulation of a rotor, the empirical information gathered to date concerning the degradation of a DC motor's insulation is insufficient and inconclusive. The behavior of the overall RMS amplitude over time in a DC motor has not been determined, and no hypothesis has been reached as to its expected behavior. Additional testing is taking place on the current signature of DC motors to more accurately identify failures and to predict failures in the future. (For additional information see the field inspection report on motor current analysis and vibration analysis located in Part II.)

CONDITION MONITORING

VIBRATION ANALYSIS OF ELECTRIC MOTORS AND MECHANICAL COMPONENTS

If equipment needed to perform a complete motor current spectrum analysis is not available, vibration analysis equipment could be used independently to detect abnormal mechanical conditions of an electric motor.⁷² A portable measuring instrument allows technicians to take vibration readings and other measurements. The hand-held instrument displays information on an LED screen, and also stores information that can be uploaded to a PC for trending and analysis. The equipment is used to detect rotor imbalances, stator damage, and rolling element defects of each bearing component. Frequency readings are used to identify the mechanical problem, while amplitude readings denote the severity of the problem.

In addition to electric motors, vibration analysis equipment could be used to detect and predict failures on all mechanical components supported by bearings, both roller and sleeve type. A hand-held device with built-in internal and external accelerometers performs fast, accurate vibration analysis and condition monitoring of bearings and rotating machinery such as pumps, fans and compressors. Vibration data can also be stored in a hand-held device and uploaded to a PC to predict failures that may occur in the future.

LOGIC CONTROLLERS TO MONITOR ELECTRICAL POWER SUBSTATIONS

Programmable Logic Controllers (PLC's) can be used to coordinate and monitor the performance of electrical power substations used for trolley buses, light rail vehicles, and heavy rail vehicles.⁷³ The technology allows for the use of "smart" circuits, diagnostics, failure identification, problem solving, and the tracking of service durations for the planning and scheduling of maintenance activities. Information is relayed to a central location where the data from multiple substations can be compiled and analyzed, providing information for a complete traction power system at one location.

CRACKED WHEEL DETECTORS FOR RAIL CARS

A prototype crack detection system that monitors the condition of steel wheels used in rail cars has been developed by the National Institute of Standards and Technology (NIST) for the Federal Railroad Administration (FRA).⁷⁴ The system is designed to detect wheel cracks before they result in catastrophic failure. A device built into the rail head of the track transmits acoustic waves into the wheel as it passes over. If a crack is present, the sound wave is dissipated into the crack sending a warning signal to the computer screen.

Test results indicate that it may be possible to use this equipment to detect wheel defects including tread thermal cracks and tread shelling. The signal processing methods used to discover wheel defects and to estimate defect size need to be modified to obtain more reliable results. The system will also need refining to achieve roll-by inspection at speeds greater than 15 mph.

CONCLUSIONS AND RECOMMENDATIONS

Many innovative and interesting maintenance technologies have been identified as a result of this project. Some require substantial investments to implement, while others are basic and rather easy to employ. All have the potential to assist managers who strive to maintain a fleet of transit vehicles in the most cost-effective manner possible.

As transit buses and rail cars become increasingly sophisticated and complex, having the appropriate tools to diagnose and repair these vehicles becomes essential in controlling costs, insuring on-time service, and improving safety. Maintenance managers have a responsibility to seek out and investigate any new technology that improves the efficiency of their operation. Keeping pace with technical developments, however, represents a real challenge to maintenance personnel who have direct responsibility for providing the appropriate number of vehicles for service each day. This report summarizes several maintenance technologies that transit managers should become aware of as they seek to improve the efficiency of their maintenance operation.

Although this report contains a wide variety of innovative maintenance technologies, it does not claim to have identified all possible technologies. Maintenance personnel should continue to expand their awareness of the many innovative tools and equipment that exist outside their own operation.

In addition to seeking new maintenance technologies, it is important that the technologies already identified by this study be evaluated to determine their appropriateness for transit applications. While the technologies identified here have the potential to improve maintenance efficiency and reduce costs, few have actually been tested and evaluated in a transit environment. Tracking the operation of these technologies in a transit maintenance environment would be useful to determine if they are actually effective and appropriate for transit applications. As advanced technology is introduced to transit, creating standards for applying this technology would also benefit maintenance.

Specific areas of additional research could include the following:

- robotic fueling for alternative fuels
- other robotic applications to improve maintenance efficiency and reduce costs
- insuring that advanced vehicle technology include provisions for ease of maintenance
- evaluate the effectiveness of technologies identified by this report, especially those currently being implemented by transit agencies
- the application of automated data collection equipment, such as those used by United Parcel Service, to transit maintenance
- environmental impact technologies
- the application of automated check lists, such as those used in the aviation industry, to transit maintenance.

REFERENCES

Low Level Technology:

- ¹ BG Products, Inc., P.O. Box 1282, Wichita, Kansas 67201, (316) 266-2686, FAX (316) 265-1082.
- ² Ken Conti, Engineering Manager - Filtration Products, Fram Division, "Does Filter Washing Make Sense?," March, 1984, 105 Pawtucket Avenue, East Providence, Rhode Island 02916, (401) 434-7000.
- ³ Sonic Dry Clean, 12255 Kirkham Rd., Ste. 200, Poway, California 92064, (619) 679-3850, FAX (619) 679-3854.*
- ⁴ Van Steenburgh Engineering Laboratories, Inc., 1900 South Quince Street, Denver, Colorado 80231, (303) 696-0113, FAX (303) 696-1077.
- ⁵ Advanced Environmental Recycling Corporation, 2591 Mitchell Ave., Allentown, Pennsylvania 18103, (215) 797-7608, (800) 554-AERC, FAX (215) 797-7696.
- ⁶ Quick Changer, International Automotive Supplies, 8350 Greensboro Drive, Suite 1009, McLean, Virginia 22102, (703) 848-8940, FAX (703) 848-2555.
- ⁷ Pall Industrial Hydraulics Corp., 2200 Northern Blvd., East Hills, New York 11548, (516) 484-5400, FAX (516) 484-5228

Como Industrial Equipment, Inc., P.O. Box 1671, Janesville, Wisconsin 53547, (608) 756-3838, FAX (608) 756-1262.
- ⁸ Nu-Tech Filter Corporation, 1205 West Crosby Road, Carrollton, Texas 75006, (214) 245-0110, (800) 869-8711, FAX (214) 245-2093.
- ⁹ Spectronics Corporation, 956 Brush Hollow Road, P.O. Box 483, Westbury, New York 11590, (516) 333-4840, (800) 274-8888, FAX (516) 333-4859.
- ¹⁰ Mighty Mat, Green Company, Environmental Products Division, 9811 Owensmouth Ave. #1, Chatsworth, California 91311, (800) 732-7477, FAX (818) 701-8881.
- ¹¹ David M. Human and Terry L. Ulman, Southwest Research Institute, "Development of an I/M Short Emission Test for Buses," SAE Paper No. 920727.
- ¹² Transmatic, Inc., Dustcontrol Environmental Products, Clairmont Plaza #1, P.O. Box 1208, Leland, North Carolina 28451, (919) 371-9911, FAX (919) 371-9859.

- ¹³ Ben Franklin Transit, 1000 Columbia Drive, S.E., Richland, Washington 99352, (509) 735-4131, (FAX) (509) 735-1800.
- ¹⁴ Vigilante, Suk-cess Limited, Wellington Street, Alverthorpe, Wakefield, West Yorkshire, England WF2 9AA, 0924 291190, FAX 0924 291895.
- ¹⁵ Air Brush, Rizvac Ltd., Inc., 110 Ford Road, Denville, New Jersey 07834, (201) 586-0033, FAX (201) 586-0049.
- ¹⁶ Vader, JIM Manufacturing, Inc., 2320 West Lake Ave., Fairmont, Minnesota 56031, (507) 235-3300, (800) 541-6299, FAX (507) 235-6812.
- ¹⁷ Electronic Flagman, Teknis Systems (Australia) Pty. Ltd., 209-217 Wakefield Street, Adelaide, South Australia 5000, +61-8-232 1690, FAX +61-8-232 1893.
- ¹⁸ Rejuvenater, IDK Technologies, Inc., 650 Poydras Street, Suite 2250, New Orleans, Louisiana 70130, (504) 524-3532, FAX (504) 568-9884.
- ¹⁹ TEDLAR PVF Film, DuPont Fabricated Products Department, Station B, Buffalo, New York 14207, (716) 879-4543, (800) 255-8386.
- ²⁰ Spallshield, DuPont Advanced Glazing Products, P.O. Box 89, Circleville, Ohio 43113, (614) 474-0681, (800) 395-0961, FAX (614) 474-0794.*
- ²¹ Electronic Sensor Company, 12461 Popash Court, North Fort Myers, Florida 33903, (813) 656-1800, FAX (813) 656-1455.
- ²² Connecticut Transit, 100 Liebert Road, P.O. Box 66, Hartford, Connecticut 06141-0066, (203) 522-8101, FAX (203) 247-1810.
- ²³ Symbol Technologies Inc., 116 Wilbur Place, Bohemia, New York 11716, (516) 563-2400, (800) 722-6234, FAX (516) 563-2831.

GenWest Rail Services, Inc., Suite D - Fresno Building, 319 South Union Avenue, Pueblo, Colorado, (719) 542-0574, FAX (719) 545-2747.

Advanced Technology:

- ²⁴ Composite Materials for Rail Transit Systems, NASA Contractor Report No. 178401, O. Hayden Griffin, Jr., Zafer Gurdal, and Carl T. Herakovich, Virginia Polytechnic Institute and State University, December, 1987.
- ²⁵ Neoplan, Gottlob Auwaerter GmbH & Co., Valhinger Str. 118-122, D-7000 Stuttgart 80 (Mohringen), (07 11) 78 35-219, FAX (07 11) 7 80 16 96.

Neoplan USA Corporation, 700 Gottlob Auwaerter Dr., Lamar, CO 81052, (719) 336-3256, FAX (719) 336-4201.

²⁶ Los Angeles County Metropolitan Transportation Authority, ATTB Office, 425 South Main Street, Los Angeles, California 90013, (213) 972-5700, Fax (213) 972-4325.

²⁷ Northrop Corporation, Aircraft Division, One Northrop Avenue, Hawthorne, California 90250-3277

²⁸ Metropolitan Transit Authority of Harris County (Houston Metro), 1201 Louisiana, P.O. Box 61429, Houston, Texas 77208-1429, (713) 739-4000, FAX (713) 739-4697.

²⁹ ETS M. Muller & Cie, 2 Avenue De La Trentaine, 77500 Chelles, France, 33 (1) 60.20.90.50., FAX 33 (1) 64.21.52.49.

MBH Maschinenbau Haldenwang GmbH & Co, D-8961 Haldenwang, Hoyen 20, Germany, (0 83 74) 933-0, FAX (0 83 74) 933 499.

Hunter Engineering, 11250 Hunter Drive, Bridgeton, Missouri 63044, (314) 731-3020.

³⁰ Regie Autonome des Transports Parisiens (RATP), 53 ter quai des Grands Augustins, 75271 Paris, Cedex 06 (France), 40.46.41.41.

³¹ The Hamilton Street Railway Company, 330 Wentworth Street North, Hamilton, Ontario, Canada, L8L 5W2, (416) 528-4200, FAX (416) 528-5410.

New York City Transit Authority (NYCTA), 370 Jay Street, Brooklyn, New York 11201-3878, (718) 330-3000, FAX (718) 852-6858.

Ministry of Transportation, Ontario, Mr. George Yanovski, Strategic Transportation Research Branch, 1201 Wilson Avenue, Downsview, Ontario, Canada M3M 1J8, (416) 235-5027, FAX (416) 235-4936.

³² Aquastripping, Lufthansa Consulting GmbH, Von Gablenzstr. 2-6, D-500 Koln 21, Germany, FAX 0221-8899660

³³ Ice Blast International Corp., 13231 23 Mile Road, Shelby Township, Michigan 48315-2713, (313) 254-9800, FAX (313) 726-4958

³⁴ Voran Safety Systems, Inc., 10802 Willow Court, San Diego, California 92127, (619) 674-1450, FAX (619) 674-1355.

- ³⁵ Greyhound Lines, Inc., P.O. Box 660362, Dallas, Texas 75266-0362, (214) 419-3981, FAX (214) 419-3923.
- ³⁶ SAF-T-BAC, P.O. Box 186, Buckeye, Arizona, 85326, (602) 386-3231, FAX (602) 842-0064.
- ³⁷ MACS, ABB Traction Inc., East Eighteenth Street, Elmira Heights, New York 14903, (607) 732-5251, FAX (607) 732-6614.
- ³⁸ DINEX (Distributed Intelligent Network Control System), Transportation Technology Company, 2952 Huntington Drive, San Marino, California 91108, (818) 309-0069, FAX (818) 309-9077.
- ³⁹ AT&T, Smart Card Systems, Room 249, 200 Cottontail Lane, Somerset, New Jersey 08873, (908) 627-8959, FAX (908) 356-8668.
- ⁴⁰ Racom Systems, Inc., 6080 Greenwood Plaza Blvd., Englewood, Colorado 80111, (303) 771-2077, FAX (303) 771-2077.
- ⁴¹ Based on a concept submitted by Dhiren K. Chakraborty, Manager - Engineering and Capital Projects, Southeastern Pennsylvania Transportation Authority (SEPTA), 200 West Wyoming Avenue, Philadelphia, Pennsylvania 19140, (215) 580-4599, FAX (215) 580-4599.
- GO ALRT, Automated Servicing and Maintenance, Phase 1: Conceptual Study, February 1984, Ministry of Transportation, Ontario, Strategic Transportation Research Branch, 1201 Wilson Avenue, Downsview, Ontario, Canada M3M 1J8, (416) 235-5027, FAX (416) 235-4936
- ⁴² Quality Systems and Integrated Logistics Support Division, Hughes Aircraft Company, Ground Systems Group, P.O. Box 3310, Fullerton, California 92534, (714) 732-8330, FAX (714) 732-7091.
- Los Angeles County Metropolitan Transportation Authority, 425 South Main Street, Los Angeles, California 90013, (213) 972-5900, FAX (213) 972-4325
- ⁴³ Unit Reliability, Availability, and Maintainability Model (UNIRAM), AIRINC Research Corporation, 2551 Riva Road, Annapolis, Maryland 21401, (301) 266-4650.
- ⁴⁴ Enhanced - Hughes Artificial Intelligence Diagnostic Expert (E-Haidex) System, Hughes Aircraft Company, Ground Systems Group, P.O. Box 3310, Fullerton, California 92534, (714) 732-8330, FAX (714) 732-7091.

System Testability and Maintenance Program (STAMP), Portable Interactive Troubleshooter (POINTER), AIRINC Research Corporation, 2551 Riva Road, Annapolis, Maryland 21401, (301) 266-4650.

- ⁴⁵ Hughes Interactive Electronic Technical Manual, Hughes Aircraft Company, Bldg. 617 M/S Y310, P.O. Box 3310, Fullerton, California 92634, (714) 732-7538.

Dr. Michael Minor, Manager - Training & Development, Union Switch & Signal, Inc., "Using Technology-Based Training to Enhance Installation, Calibration, Maintenance and Repair Skills For High Tech Signal and Control Systems and Equipment," presented at the Association of American Railroads East Regional Meeting, April 1993.

L. S. Boehmer, President, LSB Technology, "Technology Tools Solve Technology Training Problems," presented at the IEEE/ASME Joint Railroad Conference, 1991.

- ⁴⁶ Hughes Portable Display Systems, Hughes Aircraft Company, Image Equipment Products, 2051 Palomar Airport Road, Carlsbad, California 92009, (619) 931-3869, FAX (619) 931-5198.

Robotics:

- ⁴⁷ Dale M. Kay, Long Island Rail Road, "Robotic Applications in Environmentally Undesirable Car Maintenance Operations," U.S. Department of Transportation, Urban Mass Transportation Administration, Report No. UMTA-NY-03-3202-86-1, 1986.

- ⁴⁸ Montreal Urban Community Transit, 800 DeLa Gauchetiere, West, C.P. 2000, Montreal, Quebec, Canada H5A 1J6 (514) 280-5100, FAX (514) 280-5193.

- ⁴⁹ W. Wiercienski, Alan R. Leek, Ministry of Transportation of Ontario, "Robotic Cleaning of Toronto Transit Commission Subway Cars: A Feasibility Study," Report No. TCT-88-02, 1988.*

- ⁵⁰ Wiener Stadtwerke (Vienna Transit), Favoritenstrabe 9-11, A-1041 Wien, Austria (0222) 501-30-3211 OW.

- ⁵¹ Los Angeles County Metropolitan Transportation Authority, ATTB Office, 425 South Main Street, Los Angeles, California 90013, (213) 972-5700, Fax (213) 972-4325.

San Francisco Bay Area Rapid Transit District (BART), 800 Madison Street, P.O. Box 12688, Oakland, California 94604-2688, (510) 464-6000, FAX (415) 464-6049.

Regional Transportation Authority (RTA), One North Dearborn Street, Suite 1100, Chicago, Illinois 60602, (312) 917-0700, FAX (312) 917-0846.

- ⁵² Societe des Transports en commun de L'Agglomeration de Bayonne (STAB), Bd de Aritxague, 64100 Bayonne, Cedex, (France), 59 52 59 53, (FAX) 59 52 03 75.
- ⁵³ Metropolitan Transit Authority of Harris County (Houston Metro), 1201 Louisiana, P.O. Box 61429, Houston, Texas 77208-1429, (713) 739-4000, FAX (713) 739-4697.
- ⁵⁴ Sandia National Laboratories, Transportation Systems Center, 9602, Albuquerque, New Mexico 87185-5800 (505) 845-8425, FAX (505) 844-3322.
- ⁵⁵ Regie Autonome des Transports Parisiens (RATP), 53 ter quai des Grands Augustins, 75271 Paris, Cedex 06 (France), 40.46.41.41.
- ⁵⁶ Windsor Industries, Inc., 1351 W. Stanford Avenue, Englewood, Colorado 80110, (303) 762-1800, FAX (303) 762-0817.*

Condition Monitoring:

- ⁵⁷ IntelligAIRE, Thermo King Corporation, 314 West 90th Street, Bloomington, Minnesota 55420, (612) 887-2689, FAX (612) 887-2689.
- ⁵⁸ Hiroshi Inatsu, Hiroki Matsuro, Kenichi Fujiwara, Kenji Yamada, and Kazutoshi Nishizawa, "Development of Refrigerant Monitoring System for Automotive Air-Conditioning System, SAE Paper No. 920212.
- ⁵⁹ Nippondenso of Los Angeles, Inc., 3900 Via Oro Avenue, Long Beach, California 90810, (310) 513-7316.
- ⁶⁰ CVI, P. O. Box 2138, Columbus, Ohio 43216, (614) 876-7381, FAX (614) 876-5648.
- ⁶¹ Sandia National Laboratories, Transportation Systems Center, 9602, Albuquerque, New Mexico 87185-5800, (505) 845-8425, FAX (505) 844-3322.
- ⁶² Pall Industrial Hydraulics Corporation, Pall Mobile Aftermarket Division, 2200 Northern Boulevard, East Hills, New York 11548, (516) 484-5400, (800) 645-6532, FAX (516) 484-6007.
- ⁶³ Filter Minder, Engineered Products Company, 2940 Airport Blvd., P.O. Box 598, Waterloo, Iowa 50704, (319) 234-0231, FAX (319) 234-8922.

⁶⁴ Fleetwatch, S&A Systems, Inc., 3939 East Highway 80, Suite 210, Mesquite, Texas 75150, (214) 613-0021, FAX (214) 613-0023.

⁶⁵ The Goodyear Tire & Rubber Company, Technical Center, Mileage Tire Engineering, P.O. Box 3531, Akron, Ohio 44309-3531, (216) 796-6841, FAX (216) 796-8752.

⁶⁶ Tire Sentry, Fleet Specialties Division, P.O. Box 4575, Thousand Oaks, California 91359, (818) 340-8181, FAX (818) 889-3982.

⁶⁷ DINEX (Distributed Intelligent Network Control System), Transportation Technology Company, 2952 Huntington Drive, San Marino, California 91108, (818) 309-0069, FAX (818) 309-9077.

⁶⁸ DINEX

GO ALRT, Automated Servicing and Maintenance, Ministry of Transportation, Ontario.

⁶⁹ Kysor, 1100 Wright Street, Cadillac, Michigan 49601, (616) 779-7500, (800) 927-7811, FAX (616) 775-5749.

Armbrust, Inc., Heavy Truck Electronics Division, ON960 Peck Road, Geneva, Illinois 60134, (708) 232-6077.

⁷⁰ TRACKER, General Railway Signal Corporation, 801 West Avenue, Rochester, New York 14602-0600, (716) 783-2000, FAX (716) 783-2099.

⁷¹ Performance Technologies, Inc., 510 Little Creek Road, Lynchburg, Virginia 24502-4114, (804) 237-2583, FAX (804) 237-2497.

SKF Condition Monitoring, 4141 Ruffin Road, San Diego, California 92123, (619) 496-3478.

⁷² SKF Condition Monitoring

⁷³ Traction Power Systems, Inc., 3536 Moonlight Bay Drive, N.W., Canton, Ohio 44708, (216) 455-7979.

⁷⁴ Robert K. Larson, Jr., Robert L. Florom, and Britto R. Rajkumar, Association of American Railroads, "Field Testing of a Wayside Wheel Crack Detection System, U.S. Department of Transportation, Federal Railroad Administration, Report No. FRA/ORD-92/07, 1992.

* Video tape is on file at APTA's Information Center for viewing. To request a copy, contact the reference source directly.

PART II:

Appendices

Appendix A - European Trip Report	A-1
Appendix B - Trip Report to Investigate Electric Motor Monitoring Technology	B-1
• CSX Railroad Shops, Huntington, West Virginia	
Appendix C - Trip Report to Investigate Remote Diagnostics of Rail Signaling and Switching Equipment	C-1
• Grand Central Station, New York, New York	
Appendix D - Trip Reports to Investigate Potential Mainten- ance Technology Transfer from Defense Related Industries	D-1
• New Cumberland Army Depot, New Cumberland, Pennsylvania	
• Sandia National Laboratories, Albuquerque, New Mexico	
Appendix E - Trip Report to Investigate Robotic Applications for Facility Cleaning	E-1
• Windsor Industries, Inc., Englewood, Colorado	

ITIME European Trip Report

TCT-93-01

Technical Report Documentation Page

ITIME European Trip Report

Prepared by: **W. Wiercienski**

Report No.: TCT-93-01

Date: May 1993

Published by: Transportation Technology and Energy Branch
Ministry of Transportation

Abstract: The trip described in this report was made by two members of the ITIME (Innovative Technology to Improve Transit Maintenance Efficiency) Task Force. The purpose of the task force is to search for new ideas and technologies that could potentially improve existing transit efficiencies with a particular emphasis on maintenance. The task force members visited France, Austria, Germany, and England between November 3rd and 20th, 1991.

The trip revealed many advanced and innovative technologies that could be applied to North American transit operations. Based on observations made during the trip, the author makes recommendations on the implementation of some of the European technologies.

Key words: Public transportation, transit technology, automated transit maintenance, funding, bus fuelling, robotics, bus design, fibre optic sensors

Distribution: By request

Copyright Status: Crown copyright

Note regarding photographs: Most of the photos were taken by the author. However, some are reproduced here from various pamphlets and publications given to the author by the transit properties during the visit. We sincerely thank the organizations for the use of these photographs and have credited the sources in each case.

ITIME European Trip Report

W. Wiercienski

Project Research Engineer
Transportation Control Technology and Systems Office
Transportation Technology and Energy Branch
Ministry of Transportation of Ontario

Published by:

Transportation Technology and Energy Branch
Ministry of Transportation of Ontario

Published without prejudice as to the application of the findings. Crown copyright reserved; however, this document may be reproduced for non-commercial purposes with attribution to the ministry.

For additional copies, write or phone:

Wojtek Wiercienski
Transportation Technology and Energy Branch
Ministry of Transportation of Ontario
Room 324, Central Building
1201 Wilson Avenue
Downsview, Ontario
Canada M3M 1J8
(416) 235-3451

May 1993

CONTENTS

	PAGE
EXECUTIVE SUMMARY	x
1/ INTRODUCTION	1
2/ PARIS	3
2.1/ Public Transportation in the Greater Paris Area	3
2.2/ RER System	3
2.3/ Paris Metro	5
2.4/ Paris Bus System	8
2.5/ RATP Finances	10
2.6/ Paris Visits	10
2.6.1/ General Impressions	11
2.6.2/ Metro Line '1' Maintenance Facility	15
2.6.3/ Bus Maintenance Facilities	18
2.6.3.1/ Championnet Garage	18
2.6.3.2/ Aubervilliers Bus Garage	21
2.6.4/ Paris ORLY-VAL System	26
2.6.5/ Paris – Robotics	31
3/ SOCIÉTÉ DES TRANSPORTS EN COMMUN DE L'AGGLOMÉRATION DE BAYONNE (STAB) – BAYONNE COMMUNITY PUBLIC TRANSPORT ASSOCIATION	39
3.1/ General Description	39
3.2/ OSCAR Fuelling Robot	45
4/ TARBES, FRANCE	51
5/ VIENNA	56
5.1/ Introduction	56
5.2/ Undercar Robotic Cleaning System	61
6/ WEBASTO AND ZEUNA STÄRKER FACILITIES	67
7/ STUTTGART/NEOPLAN	70
8/ COLOGNE	76

CONTENTS (cont.)

	PAGE
9/ ENGLAND	82
9.1/ London	82
9.2/ Herga	85
9.3/ Manchester Light Rail Show	87
10/ CONCLUSIONS AND RECOMMENDATIONS	93
APPENDIX – Organizations and Contacts	A1

FIGURES

	PAGE
Section 1	
1.1/ The Locations Visited	2
Section 2	
2.2.1/ Map of RER Network	4
2.3.1/ Map of Metro System	7
2.3.2/ New BOA Train	7
2.4.1/ Map of Paris Bus System	9
2.4.2/ Paris R312 Bus	9
2.6.1.1/ Comatec Employee Cleaning Station	13
2.6.1.2/ Entrance to New Renault Bus	13
2.6.1.3/ Driver's Area – Compartment Open	14
2.6.1.4/ Engine Access Door to New Renault Bus	14
2.6.2.1/ Old Rail Car Before Refurbishing (Line 1)	16
2.6.2.2/ Refurbished Line 1 Rail Car	16
2.6.2.3/ Refurbishing of Line 1 – "Paint Booth"	17
2.6.2.4/ Completely Refurbished Line 1 Train	17
2.6.3.1.1/ Vehicle Fuelling Lane with Ground Level Exhaust	19
2.6.3.1.2/ RATP No-Drip Fuelling Nozzle	19
2.6.3.1.3/ Service Lane - Use of Overhead Fluid Dispensers	20
2.6.3.1.4/ Service Lane with Central Vacuum	20
2.6.3.2.1/ Under Body Wash System	22
2.6.3.2.2/ Brake Dyno – General View	22
2.6.3.2.3/ Front End Play Detector Plate and Hand Controller	23
2.6.3.2.4/ Brake Dyno Analog Display	23
2.6.3.2.5/ Brake Dyno – Pressure Transducers with Cables Clearly Visible	24
2.6.3.2.6/ Brake Dyno Test Output	25
2.6.4.1/ Map of ORLY-VAL System	27
2.6.4.2/ ORLY-VAL Train	28
2.6.4.3/ ORLY-VAL Ticket Dispensing Machines	28
2.6.4.4/ ORLY-VAL Control Centre	29
2.6.4.5/ ORLY-VAL Jacking System	29
2.6.4.6/ ORLY-VAL Bogie – Front View	30
2.6.4.7/ ORLY-VAL Service Vehicle	30
2.6.5.1/ Prototype of Cleaning Robot by Midi Robots	33
2.6.5.2/ C.A.B.X. Cleaning Robot	33
2.6.5.3/ External Vacuum Hose	34

FIGURES (cont.)

	PAGE
2.6.5.4/ Robot Climbing Stairs	34
2.6.5.5/ C.A.B.X. Debris Collection Area with Fire Extinguishing System	35
2.6.5.6/ P.A.T. Tracked Platform	35
2.6.5.7/ The Carriage Robot: A2R	36
2.6.5.8/ The Arch Robot: Elfe A	36
2.6.5.9/ Floor Cleaning Robot	37
2.6.5.10/ New Floor Cleaning Prototype	37
2.6.5.11/ Vacuum Cleaning Robot	38
2.6.5.12/ Window Cleaning Robot	38
 Section 3	
3.1.1/ STAB Facility - Aerial View	41
3.1.2/ Robotic Fuelling Lane	41
3.1.3/ Outdoor Garage	42
3.1.4/ Cleaning the Interior of the Bus	42
3.1.5/ Curb-style Vacuum Receptacle	43
3.1.6/ AVL System	43
3.1.7/ STAB Bus Refurbishing	44
3.1.8/ Overhead Exhaust System	44
3.2.1/ Original RATP Fuelling Robot	47
3.2.2/ Schematic Layout of OSCAR Fuelling Robot	47
3.2.3/ View of Robotic Fuelling Bay	48
3.2.4/ View of OSCAR Robot from Bus Side	48
3.2.5/ Side View of OSCAR Robot Fuelling a Bus	49
3.2.6/ Gas Nozzle Receptacle	49
3.2.7/ Custom Design Wheel Well Used as Part of Robotic Fuelling Station .	50
3.2.8/ Bus/Driver Information Input Panel	50
 Section 4	
4.1/ Cone Machine – Right Side	52
4.2/ Cone Machine – Driver's Side	52
4.3/ Cone Machine Control Panel	53
4.4/ Close-up View of Cone Bins	53
4.5/ Cone Collection Mechanism	54
4.6/ Cone Deployment Mechanism	54
4.7/ Comparison of French Cone (left) and CALTRANS Cone (right)	55

FIGURES (cont.)

	PAGE
Section 5	
5.1.1/ Vienna Low-Floor Bus	57
5.1.2/ Vienna Streetcar	57
5.1.3/ Vienna Streetcar	58
5.1.4/ Steerable Bogie with Disc Brakes	58
5.1.5/ Maintenance Building	59
5.1.6/ "Means of Transportation" at Vienna Maintenance Facility	59
5.1.7/ Interior of Vienna Subway Maintenance Building	60
5.1.8/ Vienna Subway Maintenance Facility Includes Under-the-floor Access	60
5.2.1/ Vienna Subway Car Arriving at the Cleaning Building	62
5.2.2/ Interior of Robotic Cleaning Bay	62
5.2.3/ Car Positioning Mechanism	63
5.2.4/ One of Four Cleaning Robots	63
5.2.5/ One of Four Bogie Cleaning Nozzle Assemblies	64
5.2.6/ Multiple-nozzle Tool	64
5.2.7/ One of the Cleaning Robots	65
5.2.8/ Robot Cleaning Compressor Assembly	65
5.2.9/ Waste Collection System Using Standard Garbage Can	66
5.2.10/ Infrared Sensor Mounted on Rail	66
Section 6	
6.1/ Zeuna Stärker Trap	69
6.2/ Trap Installed in a Bus	69
Section 7	
7.1/ Neoplan Factory Second Floor	72
7.2/ Neoplan Double-decker Frame	72
7.3/ Front Suspension of Neoplan Bus	73
7.4/ Neoplan Metroliner 8008 Model Specs	73
7.5/ Neoplan Metroliner Model 8008	74
7.6/ Neoplan Metroliner Suspension Detail	74
7.7/ Set of Parts Required to Produce Metroliner Body	75

FIGURES (cont.)

	PAGE
Section 8	
8.1/ IBIS System Overview (Integrated On-board Information System)	78
8.2/ Central Unit with Integrated Driver Terminal, Example 1 for Key Allocation	79
8.3/ Low-Floor Articulated Bus Standard	80
8.4/ "Line-bus" Standard	80
8.5/ VDV Low-Floor Streetcar Prototype	81
8.6/ Luggage Carrying Belt at Cologne Rail Station	81
Section 9	
9.1.1/ Docklands Railway System Plan	84
9.1.2/ Docklands Train with a "Station Master"	84
9.2.1/ Herga Sensor Principle	86
9.2.2/ Herga Sensor Construction	86
9.3.1/ Milan Low-Floor Car Next to Older Model	88
9.3.2/ Bogies for the Above Cars (low floor in foreground)	88
9.3.3/ Bombardier LRV 2000 Low-Floor Car and Bogie	89
9.3.4/ Bogie for Bombardier LRV 2000 Low-Floor Car	89
9.3.5/ Bombardier Train 2000 for Brussels	90
9.3.6/ Bogie for Bombardier Train 2000 for Brussels	90
9.3.7/ German Low-Floor Car	91
9.3.8/ Bogie for German Low-Floor Car	91
9.3.9/ Composite Applications	92

EXECUTIVE SUMMARY

The Ministry of Transportation of Ontario (MTO) and the Urban Mass Transportation Administration (UMTA), now the Federal Transit Administration (FTA), have jointly funded the Innovative Technology to Improve Transit Maintenance Efficiency (ITIME) Task Force.

The purpose of the task force is to discover, evaluate, and recommend new or innovative technologies to improve the maintenance efficiency of transit operations. The task force is co-chaired by Mr. Bob Graham (U.S.) and Mr. Wojtek Wiercienski (Canada). Administrative matters are handled by the Transit Development Corporation (TDC).

One activity recommended by the task force was a trip to Europe to survey advanced technology that could improve maintenance efficiency and reduce operating costs. The European trip was taken by Mr. John Walsh, Assistant Chief Maintenance Officer, New York City Transit Authority, New York, N.Y., and Mr. Wojtek Wiercienski, Co-chairman of the task force and Project Research Engineer, MTO, Toronto, Ontario. The trip took place from November 3 to November 20, 1991 and included visits to France, Austria, Germany, and England. Their findings are summarized in this report.

MAIN FINDINGS

Technology, Funding, and Co-operation – The trip to Europe revealed a variety of advanced technology applications to public transportation, including sophisticated electric vehicle propulsion systems for bus and rail, the use of robotics for cleaning operations, automatic train controls, and automated diagnostic systems. Much of this technology has progressed beyond research and development projects to commercial production.

Funding for the development of these systems is frequently provided by a cooperative arrangement between the public and private sectors. Many European transit systems are also fully funded by central governments to apply the advanced technology to their local operations. The contrast between the active financial involvement by European governments and the limited resources available from the North American governments for public transit research is acute.

European transit associations also appear to have a much closer working relationship with government agencies and the private sector. For example, the German Association of Transit Agencies (VDV) – the equivalent of the American Public Transit Association (APTA) – has worked together with manufacturers and the government to produce common specifications for all types of transit vehicles. This includes a standard specification for a low-floor transit vehicle, as well as standards for on-board electronic hardware for communications and data bases. The potential savings resulting from this standardized approach are extensive.

Cleaning Robots – In many cases, some European transit systems have found it cost-effective to contract their rail and bus cleaning operations to outside suppliers, while retaining their maintenance operations in-house. In some cases, robots have been introduced to improve the safety and efficiency of these cleaning operations.

The Paris metro (RATP) has contracted with Comatech to clean transit vehicles and rail stations. To improve the efficiency of cleaning operations, a consortium was formed to develop automated robotic systems. These systems are currently being tested in specific applications, including those that require the robots to ascend/descend stairs. Due to cost considerations, the wide-scale application of this type of robotic station cleaning system is years away. Robotic cleaning systems that are less complicated and less expensive are also being developed and these will have a much shorter introduction period.

In Vienna, Austria, an automated system is currently being used as an alternative to manually cleaning the underside of rail cars. Manual cleaning is labour-intensive and presents a health hazard due to the large amounts of airborne dust and dirt, especially from carbon brushes. The automated cleaning system uses commercial assembly robots, which have been modified with high-pressure air jets and a vacuum system to dislodge and collect dust and dirt.

London Underground expects to contract out its cleaning operations and expects robotics to be used for undercar cleaning.

Automated Brake and Front Suspension Inspection – The RATP, along with other large European transit systems, are currently using automated brake and front suspension inspection systems for transit buses. The device, which is easily installed in existing inspection lanes with a pit, tests brake efficiency along with steering and front suspension free-play. Results are analyzed by microprocessors, printed out as reports, and sent to a central data bank for maintenance scheduling and future reference.

The brake/suspension test equipment can be used with existing preventive maintenance programs, or as a diagnostic tool to correct brake and suspension problems. It has the potential to replace some government mandated on-the-road tests required after brake relining and certain accidents, which is a labour-intensive operation. In addition, the equipment can be used with another system to test the vehicle's power module (engine, transmission, and final drive).

Automated (Robot) Fuel Stations – The regional transit authorities in Bayonne and Toulouse, France are developing a fully automated fuelling operation. A minimal amount of human involvement is required to fuel, and to download information from the buses. A robot senses the position of each bus, locates the fuel intake fixture, and

fills the fuel tank while the driver enters odometer information, using a key pad that is accessible through the driver's side window.

This refuelling system could be especially useful for dispensing certain alternative fuels, such as methanol and natural gas, because of increased fuelling times and safety concerns.

Electronic Standards - The Germans have developed a standardized specification for bus hardware, communication protocols, and interfaces to accommodate a variety of vehicle location systems. The standardization allows global positioning systems, odometer systems, or other bus location systems to be easily installed.

As a result, the on-board systems are more functional, less troublesome, and much less expensive than custom developed North American ones.

New Bus Designs – Neoplan, a German bus manufacturer, has developed a new approach to bus design. To improve fuel economy and exhaust emission and to accommodate low-floor designs, Neoplan is using carbon fibre technology to reduce vehicle weight. Lighter unibody-construction buses use smaller, more fuel-efficient engines, and can extend the life of suspension and other vehicle subsystems.

Neoplan's new bus design also uses a low-floor concept, without steps for easier ingress and egress. This feature is useful for efficient passenger flow and to assist elderly and handicapped passengers, especially those using wheelchairs. Low-floor designs, currently used throughout Europe, may be useful in meeting ADA requirements in the United States and in general greatly decrease stop dwell time.

Fibre-Optic Sensors – Transit systems in England are currently evaluating the use of fibre-optic technology for highly sensitive and reliable door-control sensors and for passenger counting applications. Initial evaluation indicates that the fibre-optic sensors could be applied to buses. Application to rapid transit vehicles, however, could present a safety problem and requires further evaluation.

Non-Transit Technology of Interest – While travelling in Europe, a specialized highway-utility vehicle was observed that automatically deploys and retrieves traffic-safety cones. Such a vehicle will be very useful to authorities who wish to physically separate special traffic lanes at frequent intervals.

CONCLUSIONS

The trip to Europe revealed many advanced and innovative technologies that could be applied to North American transit operations. While some are readily available and could be applied immediately, others require additional development and offer possible applications for the future.

The trip also revealed that research and development programs in North America are inadequate when compared to transit programs in Europe. With limited funding, North American transit systems need to strengthen their partnerships with government agencies and the private sector. These partnerships could identify, develop, and apply advanced technology to public transportation operations to make them more efficient.

1/ INTRODUCTION

The Ministry of Transportation of Ontario (MTO) and the Urban Mass Transportation Administration (UMTA) now the Federal Transit Administration (FTA) together with the American Public Transit Association (APTA) and the Canadian Urban Transit Association (CUTA) have commissioned Transit Development Corporation (TDC) to create a task force on Innovative Technology to Improve Transit Maintenance Efficiency (ITIME). The purpose of the task force is to search for new ideas and technologies that could potentially improve existing transit operations with particular emphasis on maintenance.

One of the task force activities was a trip to Europe taken by two of its members: Mr. J. Walsh, who was Chief Maintenance Officer at the time, Surface Transit, New York City Transit Authority, and Mr. W. Wiercienski, Project Engineer, MTO and co-chairman of the task force.

The trip took place between November 3rd and November 20th, 1991. The participants visited France, Austria, Germany, and England with a brief one-day stop-over in Holland (Rotterdam) by Mr. Walsh to view Philips' VETAG System. The locations visited are shown in Figure 1.1.

This report is organized by locations visited and subjects within these locations. It should be noted that the observations and conclusions expressed in this report are those of the author, not the participating organizations, and that the author alone is responsible for various observations and opinions.

The trip participants would like to thank most sincerely the organizations and individuals visited, who without exception were most helpful and informative and hence made the visit worthwhile and enjoyable. Some of the organizations and individuals who contributed are listed in the appendix.

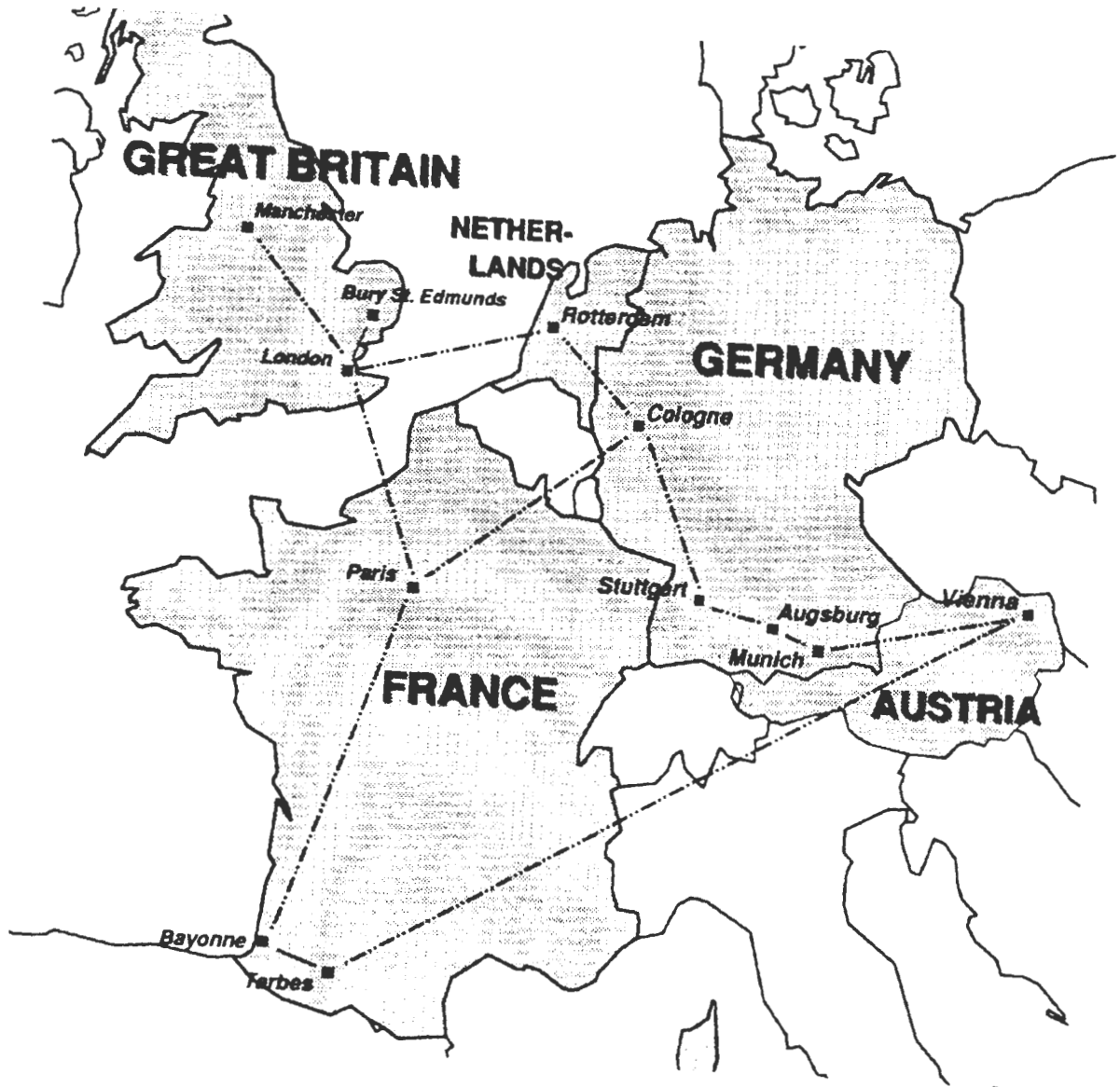

Figure 1.1/ The Locations Visited

2/ PARIS

2.1/ Public Transportation in the Greater Paris Area

Paris, the starting point of the trip, has an extensive and modern transit system.

The Greater Paris Area is made up of eight districts: Paris, Hauts de Seine, Seine Saint Denis, Val de Marne, Essonne, Val d'Oise, Yvelines, and Seine et Marne.

This region, known as "Ile de France," is inhabited by roughly 10 million people, a figure almost unchanged during the last few years. The employment level stands at five million (40% in the city of Paris itself), again almost unchanged since 1975.

Paris region transportation is provided by the Paris Transport Syndicate (STP), an autonomous public transport authority. The syndicate appoints operators, sets fares, provides central planning, determines the routes, and in general directs the running of the system.

There are four STP appointed operators who provide the actual services: RATP, SNCF, APTR, and ADATRIF.

RATP covers a central 1200 square kilometre area, and together with SNCF practically has a monopoly on public transportation. RATP operates the metro system, the suburban rail RER system (together with SNCF), and the bus system. It transports roughly 2.4 billion passengers per year. The French national railway, SNCF, transports an additional 500 million passengers per year.

Additional services are provided by APTR (Professional Association of Road Transportation Operators) and by ADATRIF (Association for Developing and Improving Transportation in the "Ile de France").

2.2/ RER System

RER is a regional express train network operated jointly by RATP and SNCF. It consists of four lines – A,B,C,D, – presented in Figure 2.2.1.

Lines A (63 km) and B (40 km) are under the authority of RATP and are jointly operated with SNCF; the remaining two lines (C and D) are operated solely by SNCF. Lines A, B, and D come together at Châtelet les Halles station, while the Saint Michel-Notre Dame station permits transfer between lines B and C.

Line A is the most heavily loaded but with computer control, the peak hour headway is about two minutes. In order to ease loading on line A, a totally automated, new 20 km metro line (METEOR) is being constructed and is scheduled for completion in 1995.

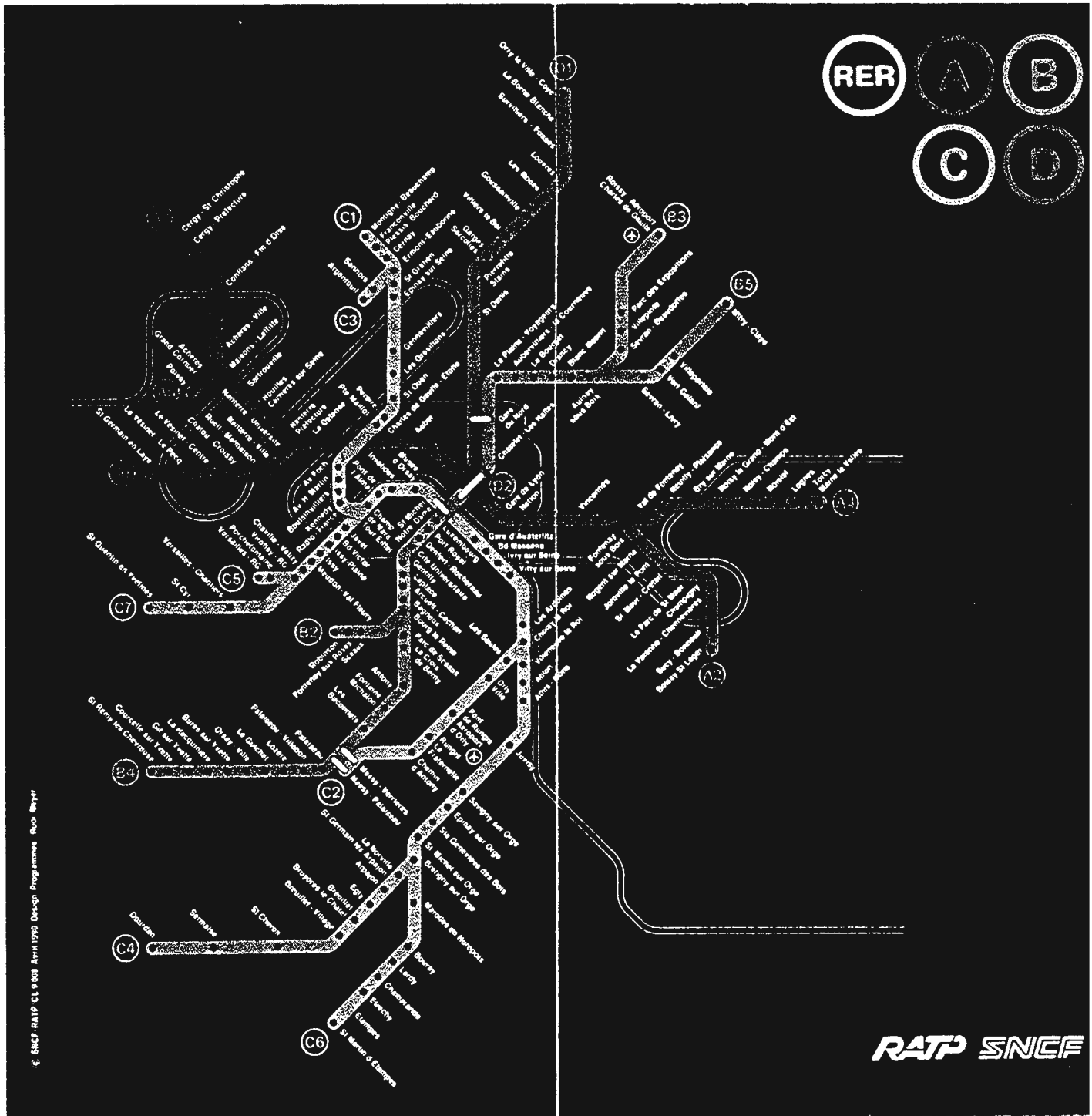

Figure 2.2.1/ Map of RER Network

Source: SNCF-RATP

2.3/ Paris Metro

The Paris metro network has 13 independent lines and two smaller feeder lines and serves both the inner city and most of the nearby suburbs as shown in Figure 2.3.1.

The network is 200 km long and there are 368 stops in 291 stations. As a result, within the city centre there is always a metro station within 500 m.

In the 1950s, RATP started a station renovation program which is continuing today at the rate of five or so stations per year. The stations are not only upgraded with new materials and decor, they are also being integrated into the community with shops, libraries, etc.

This policy has created a very pleasant underground system. It should be noted that the space allocation is non-discriminatory, even permitting a shop that sells materials to graffiti artists, who execute their "designs" on the metro trains or station walls.

Different lines use either rubber-tire wheels or steel wheels with a conventional 1.44 m gauge. The power (750 volts DC) is supplied via a third rail.

The last pre-war trains were taken out of service in 1983 and the oldest cars (articulated) date to 1952. At the end of 1987, there were 60 articulated cars (36 motor cars and 24 trailers), 799 rubber-tired cars (526 motor cars and 273 trailers) and 1063 steel-on-steel cars (249 motor cars and 814 trailers).

A new train called BOA (Figure 2.3.2) is currently being developed. It will be totally automated with steel wheels, self-steering bogies, and flexible gangways between adjoining cars. In the meantime, some cars (Line 1 stock) are being refurbished.

According to RATP, the operation of the metro is governed by three main factors: simplicity, safety, and regularity.

Simplicity means that all the lines are physically independent, although there are transfer points permitting movement of rolling stock between them. A flat rate system of fares is complemented by a season ticket ("orange card") plus various other discount fares.

Safety is a first priority, as everywhere else. It should be noted, however, that the metro doors open while the train is still in motion (speed below 5 km/h). While this practice speeds up the unloading of passengers, it may be considered unsafe by North American transit properties.

Regularity refers to the fact that the trains run with regular headway, which is adjustable through the day. During the peak hours, the trains are driven automatically by the Automatic Train Operation System with the operator simply monitoring the computer;

during off-peak hours, they are driven manually. The minimum headway is 95 seconds and it is claimed that computer control has increased passenger capacity by 15% to 20%. The train departure time is computer controlled, and the remaining dwell time is displayed for the drivers at platforms in minutes and seconds. By adjusting the dwell in real time, the computer can keep uniform spacing between trains. This system appears to work very well; we observed very frequent service and uniform loading at almost any time of day.

At 1.2 billion trips per year (a 1987 figure), the metro carries slightly more than 50% of RATP traffic with winter traffic reaching five million trips daily.

The metro's staff, facilities, and levels of service are listed below:

- **staff**

- 4100 stationmasters, of whom 2250 are women;
- 2650 drivers, of whom 100 are women;
- 1600 workers for the maintenance of the rolling stock in the terminals, and the 12 maintenance and overhaul shops.

- **facilities**

- 520 km of single track;
- 60 km of station platforms and 75 km of corridors;
- 403 escalators, 17 elevators, and 6 moving sidewalks;
- 217 high-capacity ventilators;
- 489 water pumping facilities.

- **service**

- 560 trains in service in the peak hours;
- 9900 train departures from the terminals daily.

The rolling stock department is responsible for making sure a maximum number of cars is available for service. They have a number of inspection stations throughout the system where they check and repair minor problems. Periodic checks, more serious problems, and train cleaning are accomplished in separate maintenance shops and major components are repaired in special overhaul shops.

The system has twelve shops: nine are for maintenance only – Charonne, Saint-Fargeau, Italie, Javel, Boulogne, Auteuil, Lilas, Vaugirard, and Pleyel – and three carry out maintenance and overhaul – Fontenay, Saint-Ouen, and Choisy.

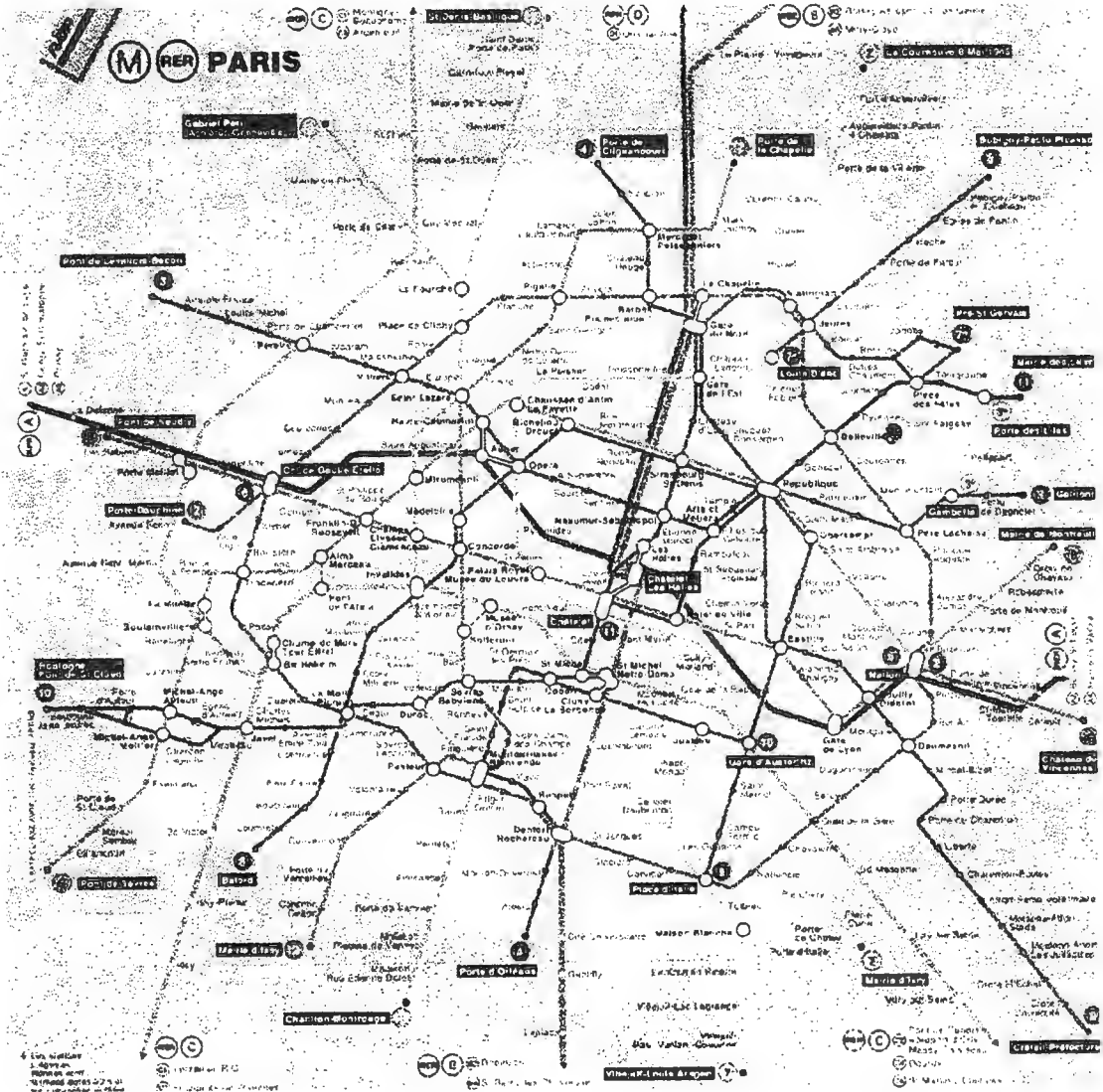

Figure 2.3.1/ Map of Metro System

Source: RATP-CPA



Figure 2.3.2/ New BOA Train

Source: RATP-CPA

2.4/ Paris Bus System

The Paris bus system is divided into a central and suburban network.

The central system, which is complementary to the metro, is 518 km long (304 km reserved lanes) and has 57 bus routes with 1680 stops. There is a circular bus route serving the Paris "gates," a night service (called Noctabus), and other special services, e.g., minibuses from Pigalle to Montmartre.

The suburban network has 140 routes totalling 1700 km (174 km reserved lanes) with 4900 stops. These are essentially feeder lines to the RER and the metro. Additional routes are operated by private companies. The bus system route plan is shown in Figure 2.4.1.

The 4000-bus (December 1987) fleet contains four basic vehicle types:

- Standard buses, SC10, first introduced in 1965, make up almost 90% of the current fleet (3572 vehicles).
- Rear engine buses, PR100, introduced in 1974 (111 vehicles).
- Articulated buses, PR180, first introduced in 1983 (255 vehicles) will in the future comprise 10% of the fleet.
- The new R312 bus (Figure 2.4.2), first introduced in 1988 is the newest addition to the fleet and is to become a "standard" vehicle. It has a very nice modern low floor (with two small steps), panoramic windows, and three double doors. It is claimed that this bus is much more easily maintained than its predecessors.

Since 1974, Paris buses have driver-only crews.

The bus fleet is housed and maintained in 22 garages, six of which are in the city. The newest are Championnet and Aubervilliers. The bus staff numbers almost 12 000 with 9400 drivers (500 female) and 2500 maintenance workers. Maintenance is claimed to be superior with 0.7 breakdowns per 10 000 km travelled.

In 1987, 760 million bus passengers were recorded (315 million city and 445 million suburban) with a maximum 2.6 million per day. About one-quarter of the fleet (1000 buses) is out early in the morning, with approximately one-third (1400 buses) still running after midnight and about 3400 buses out during peak hours.

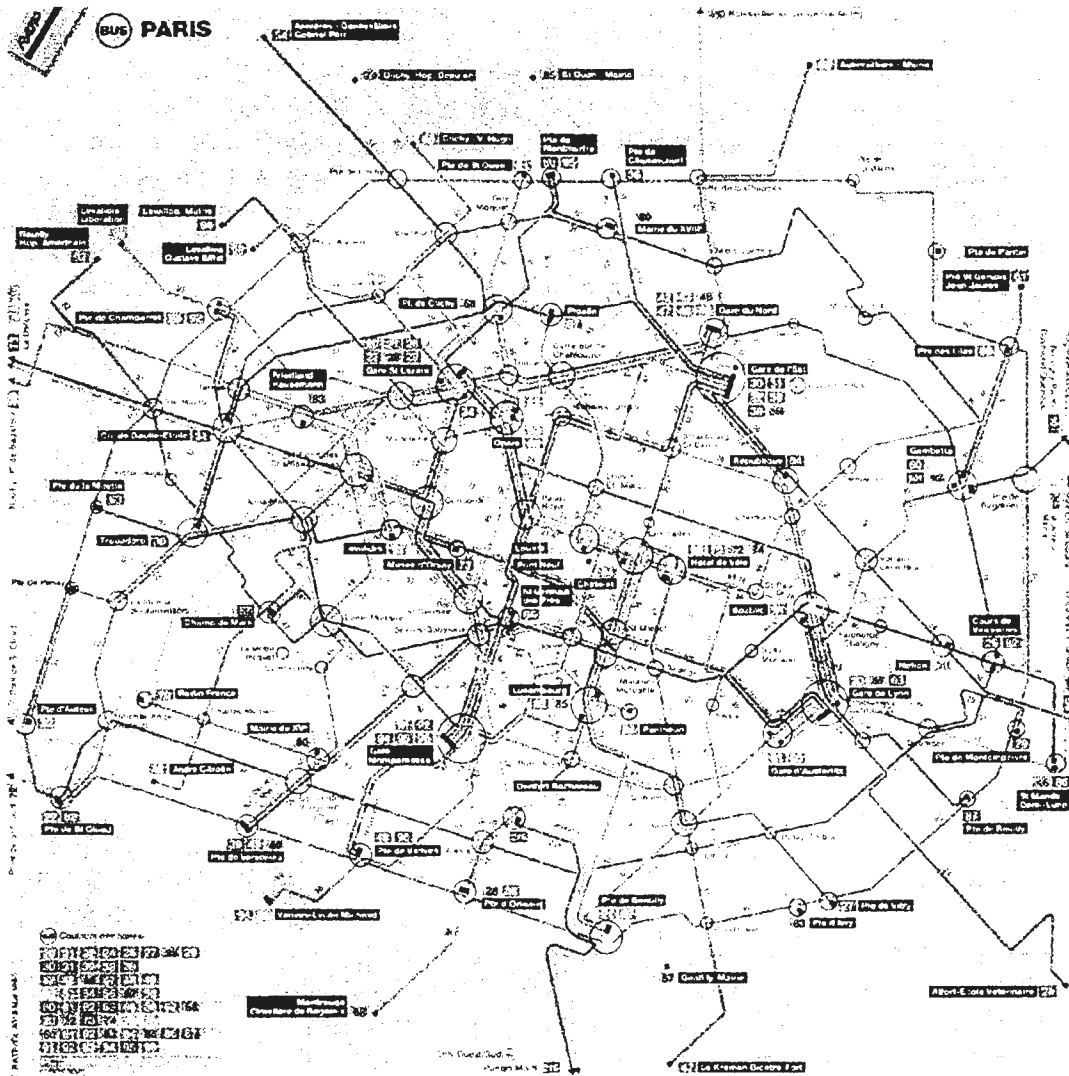

Figure 2.4.1/ Map of Paris Bus System

Source: RATP-CPA



Figure 2.4.2/ Paris R312 Bus

Source: RATP-CPA

2.5/ RATP Finances

RATP has its rates set by the Paris Transport Syndicate and is required to have a balanced budget. Its revenues are derived from its transportation activities (90%) and other products (10%).

Passenger fares provide 40% of the transportation income and the remaining is either compensatory payments to account for various rate reductions (18%) from various employers and governments or subsidy (42%) to provide for artificially low transit fares (70% state, 30% municipality).

Substantial ongoing capital investment is paid for by self-financing, various government subsidies, loans, bond issues, or even private capital (e.g., ORLY-VAL system).

Some of RATP income comes from SOFRETU, a highly regarded and very active consulting subsidiary.

2.6/ Paris Visits

The participants visited the following:

- a metro maintenance facility for rubber-tired trains
- two bus garages
- a robot testing depot at Châtelet les Halles and robot design company
- the ORLY-VAL system

The tour arrangements were made by SOFRETU and various RATP personnel to whom we express our sincere thanks.

2.6.1/ General Impressions

The trip participants made extensive use of the metro system which is certainly the most convenient means of transportation around the city. Wherever one is, there is a convenient metro station, particularly in the centre of the city. The trains are plentiful, clean, and inexpensive. They are used extensively – there appeared to be a fair amount of passengers at almost any time.

Many stations have various shops and service establishments and are visually pleasant. The passenger information is excellent. In fact, it would be difficult to get lost.

The trains and the stations are very clean, although graffiti is a bit of a problem, particularly in the outlying areas. The cleaning is contracted to a private company (Comatec) and its distinctly dressed personnel (Figure 2.6.1.1) are highly visible.

There are many connecting stations between various lines and the walk is sometimes substantial. On the other hand, there are many colourful advertisements along the way to make the walk pleasant.

The buses, which complement the metro, appear to be plentiful and regular, perhaps due to a large number of special bus lanes and a traffic signal priority scheme. The passengers are greatly assisted by on-board route maps.

The new Renault buses (R312) are particularly nice with large panoramic windows, easy entry, wide doors, and two low steps (Figures 2.6.1.2). The driver sits in a small enclosure (Figure 2.6.1.3). The seats are comfortable and the ride pleasant. A good engine access door makes mechanical servicing quite easy (Figure 2.6.1.4).

The RER system provides convenient transport to the outlying areas and is well integrated with the metro.

Excellent, although more expensive, service is provided to Orly airport by the VAL system.

Computers and electronics are used extensively to make life easier for transit personnel and to provide good passenger information.

The fares are very reasonable: 10 rides for 35 FF (approximately \$6.50 Cdn.) and various cheaper discount fares (e.g., "orange card") are available.

Magnetically encoded tickets have been used since the early 1960s, a good example of the fact that RATP implements many modern technologies before anyone else.

In general, Paris has an excellent, modern transit system which is used extensively. Perhaps as the result of this, it appears that car traffic has decreased somewhat during the last few years since this writer's previous visit to Paris.



Figure 2.6.1.1/ Comatec Employee Cleaning Station

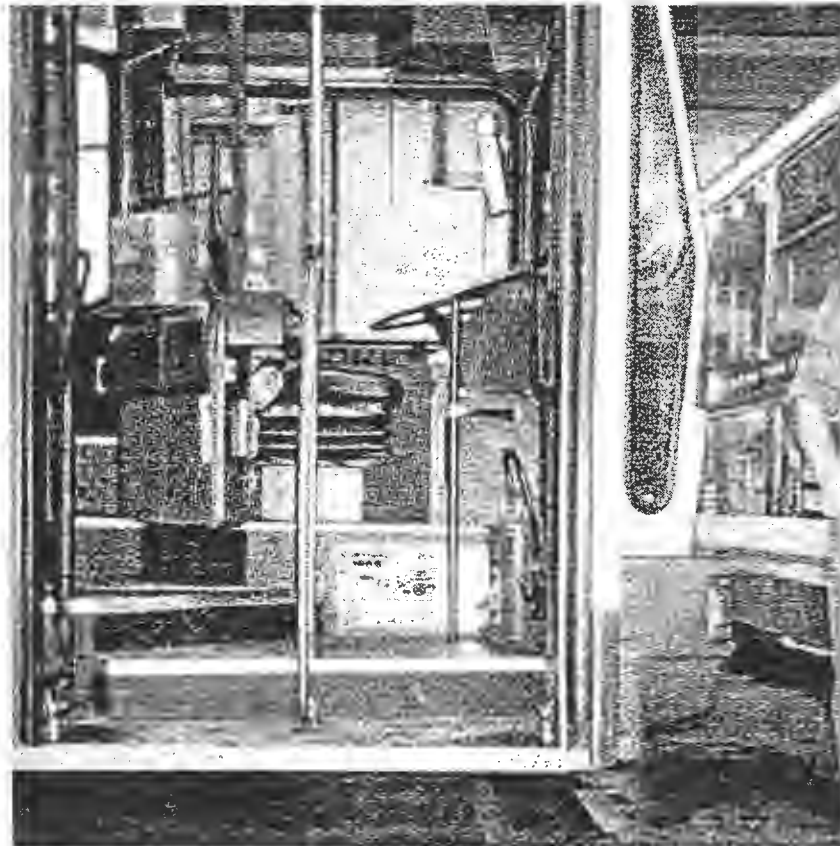

Figure 2.6.1.2/ Entrance to New Renault Bus

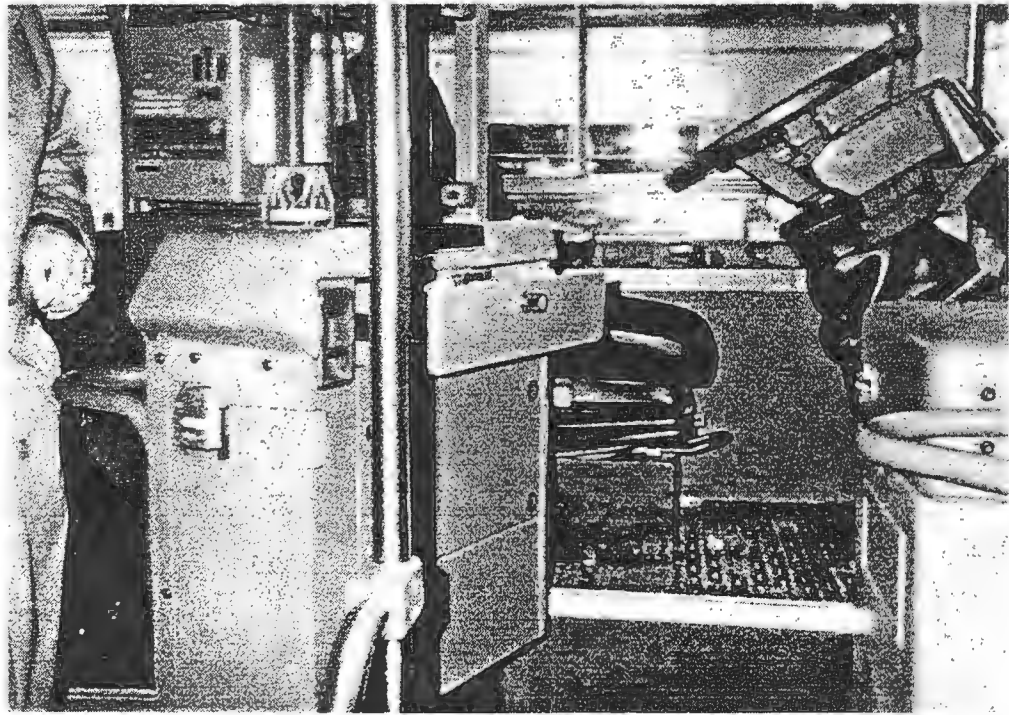

Figure 2.6.1.3/ Driver's Area – Compartment Open



Figure 2.6.1.4/ Engine Access Door to New Renault Bus

2.6.2/ Metro Line '1' Maintenance Facility

The line '1' maintenance workshop repairs and refurbishes rubber-wheeled trains. It is located walking distance from the Fontenay-sous-Bois RER station.

The shop provides routine maintenance to rubber-tired trains and was, at time of the visit, engaged in the rebuilding of rail cars for metro line 1.

Most of the actual refurbishing is done by outside parties, but some trains are refurbished in-house. One contractor is located near Cannes, and another in central France. A rail wagon is delivered to the contractor and later brought back by a special truck. The refurbishing operation takes about one week.

Refurbishing involves substantial body work and the necessary mechanical repairs. The cars receive a completely new front (Figures 2.6.2.1 and 2.6.2.2), interior, and lighting. The painting is shown in Figure 2.6.2.3 and the completed train in Figure 2.6.2.4.

The no-frills, well-organized approach is reflected in the most reasonable refurbishing cost of approximately \$100,000 U.S. per car.



Figure 2.6.2.1/ Old Rail Car Before Refurbishing (Line 1)

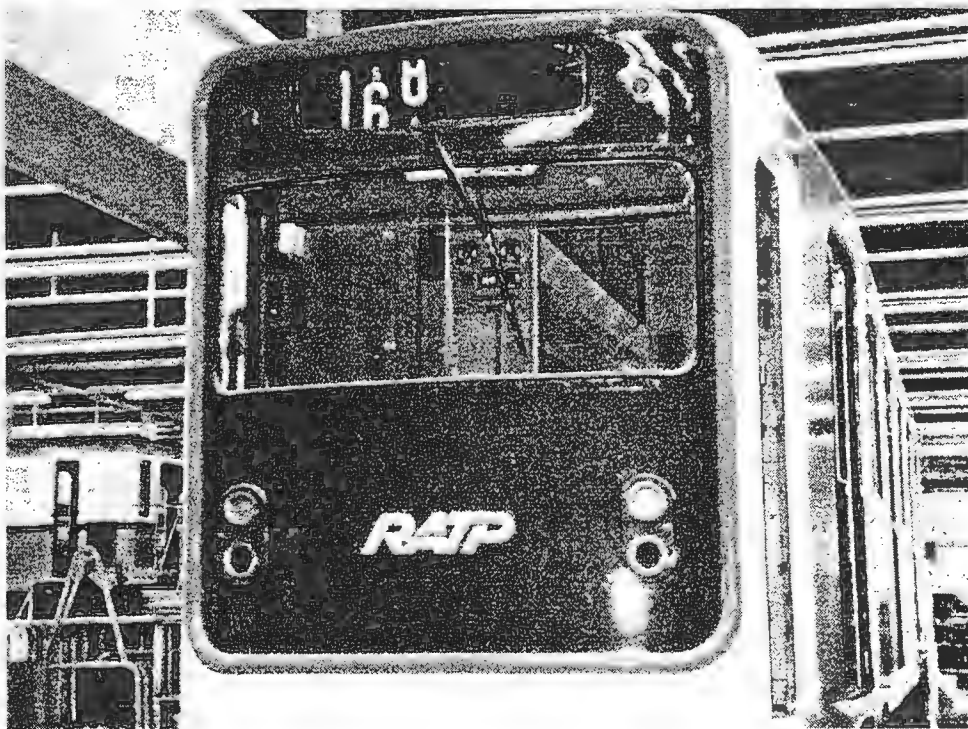

Figure 2.6.2.2/ Refurbished Line 1 Rail Car



Figure 2.6.2.3/ Refurbishing of Line 1 - "Paint Booth"

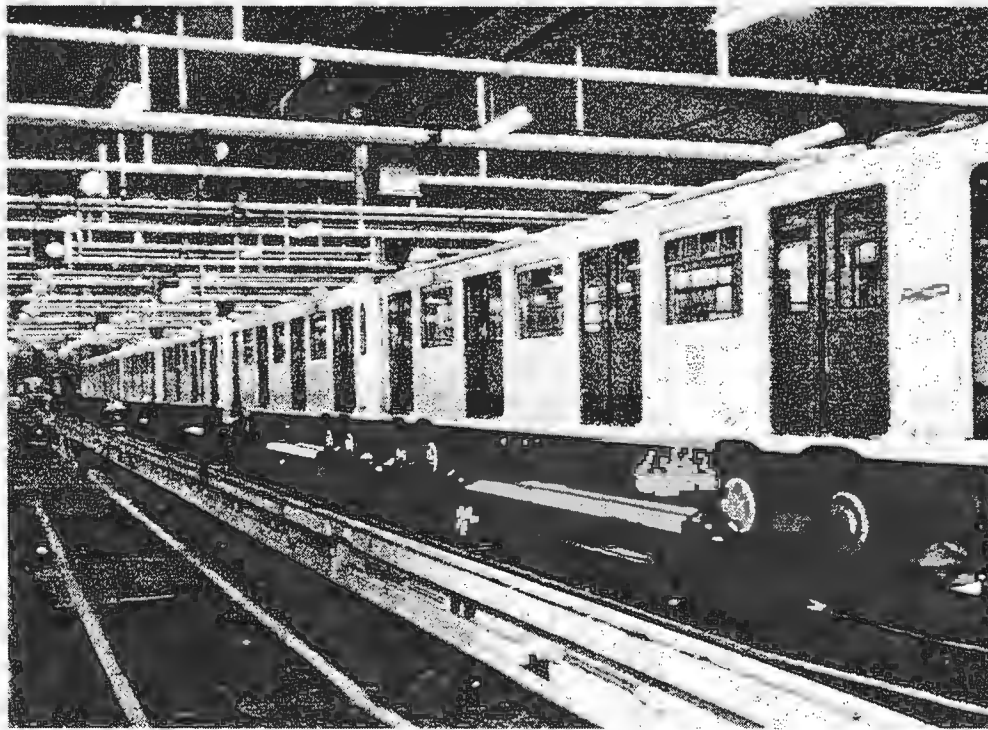

Figure 2.6.2.4/ Completely Refurbished Line 1 Train

2.6.3/ Bus Maintenance Facilities

Two facilities were visited, both located in the north of the city: one at Rue Championnet and the other at Aubervilliers.

2.6.3.1/ Championnet Garage

The Championnet Garage is an older garage located well within the city boundaries and surrounded by high-rises. A variety of buses including articulated buses are stored and maintained there. Less serious repairs are also carried out at the facility.

While North American transit properties tend to do daily maintenance in single-service lanes, the same operations at Championnet are actually split, perhaps due to a different philosophy and different weather conditions.

The vehicle fuelling is accomplished in a special lane which is equipped with floor level exhaust (Figure 2.6.3.1.1). Although RATP originally experimented with robotic fuelling in the mid-1980s, they are now using a system with a special no-drip nozzle (Figure 2.6.3.1.2). The system is semi-automated i.e., the nozzle has to be inserted manually but the amount of fuel is automatically recorded. Furthermore, the driver is advised (via a light) that the nozzle is still attached to the bus.

Other fluid checking, minor servicing, and interior cleaning are done in separate lanes which are equipped with overhead fluid dispensers, portable jacks, and central vacuum hoses for floor cleaning (Figures 2.6.3.1.3 and 2.6.3.1.4). As the fleet has some articulated buses, the overhead exhaust hoses can be moved along, a feature also seen in other locations. The drive-through bus washer is located outside.

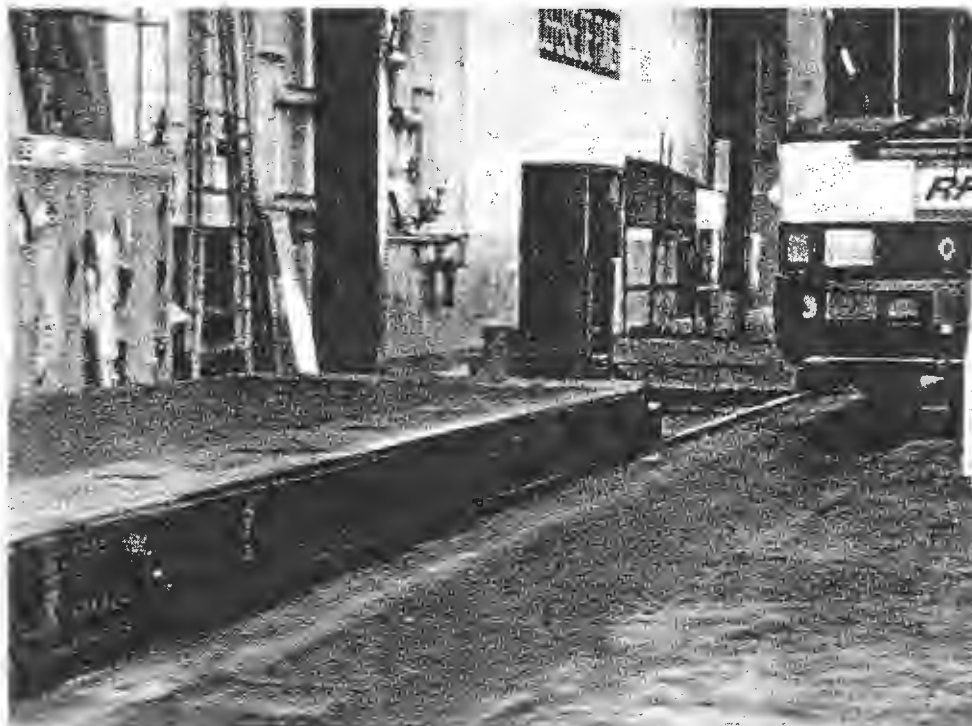

Figure 2.6.3.1.1/ Vehicle Fuelling Lane with Ground Level Exhaust



Figure 2.6.3.1.2/ RATP No-Drip Fuelling Nozzle

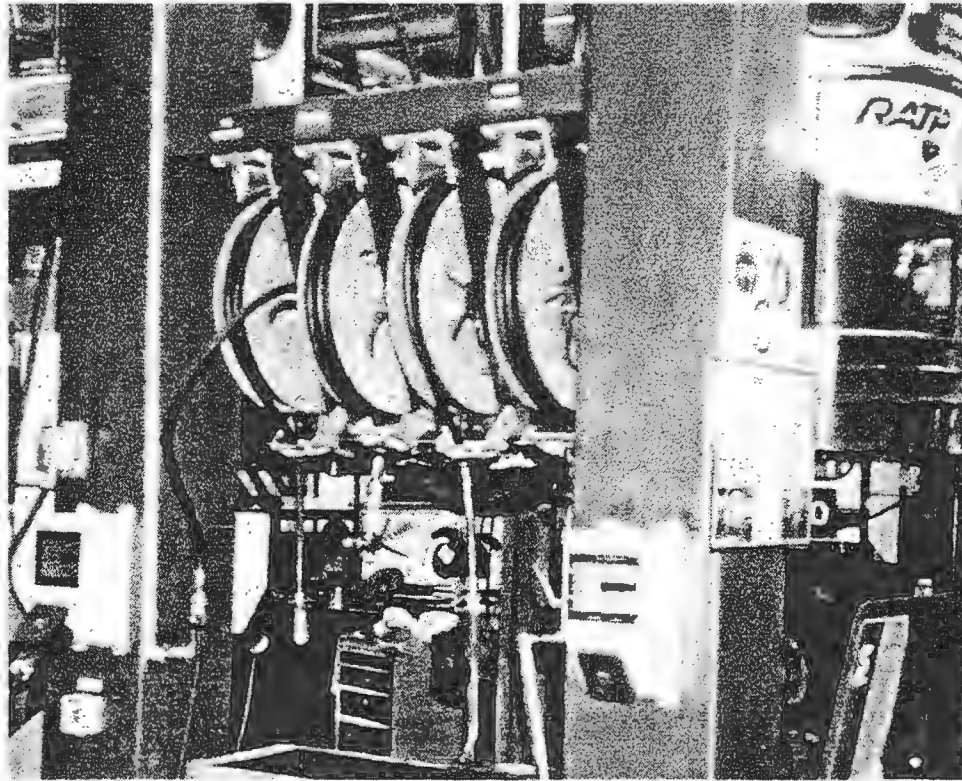

Figure 2.6.3.1.3/ Service Lane - Use of Overhead Fluid Dispensers

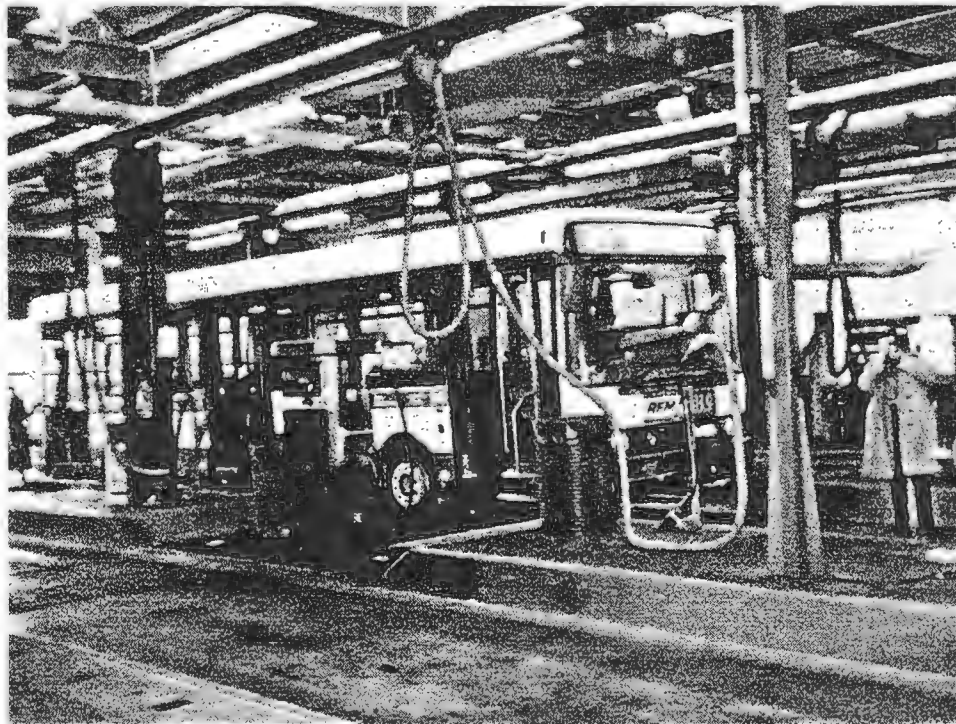

Figure 2.6.3.1.4/ Service Lane with Central Vacuum

2.6.3.2/ Aubervilliers Bus Garage

This is a major new bus maintenance facility which was, at the time of our visit, in the final finishing stages.

In this thoroughly modern facility, the following attracted our attention: the building design, a "pit" system, underbus washing bays, a waste treatment plant, brake testing equipment, and automated parts storage and retrieval.

The building is very modern with a lot of glass and hence excellent visibility. The structure is somewhat unconventional as the supporting steel is outside instead of inside, resulting in more spacious accommodation.

In the service area, there is a complete sub-floor level which permits work on under-carriages without the necessity of lifting the vehicles. This is not the usual system of pits but a complete sub-basement level with few obstacles. The pits are equipped with height-adjustable walkways for the mechanics, permitting the correct working height for each individual. The adjustable walkways are made by Sefac.

The building has two underbus washing robots produced by Chassijet (Figure 2.6.3.2.1) suitable for articulated vehicles. These areas drain to a central waste processing facility.

The garage is equipped with multiple brake dynos (by Bem Muller and MAHA). The dynos are pit mounted (Figure 2.6.3.2.2). They include suspension testing plates (Figure 2.6.3.2.3) and are fully equipped with both analog and computer displays (Figure 2.6.3.2.4).

The dynos are equipped with sensors which can be directly connected to test points on the bus (Figure 2.6.3.2.5) thus permitting pressures to be read. A multicolour printer records test results in graphical form (Figure 2.6.3.2) if required.

The facility has quite interesting computerized small parts storage – the parts are stored in a compact "cupboard" and individual items accessed from a computer terminal.

In all, the Aubervilliers garage is a completely modern maintenance facility which provides greater efficiency and uses modern technology to a considerable extent.



Figure 2.6.3.2.1/ Under Body Wash System



Figure 2.6.3.2.2/ Brake Dyno - General View

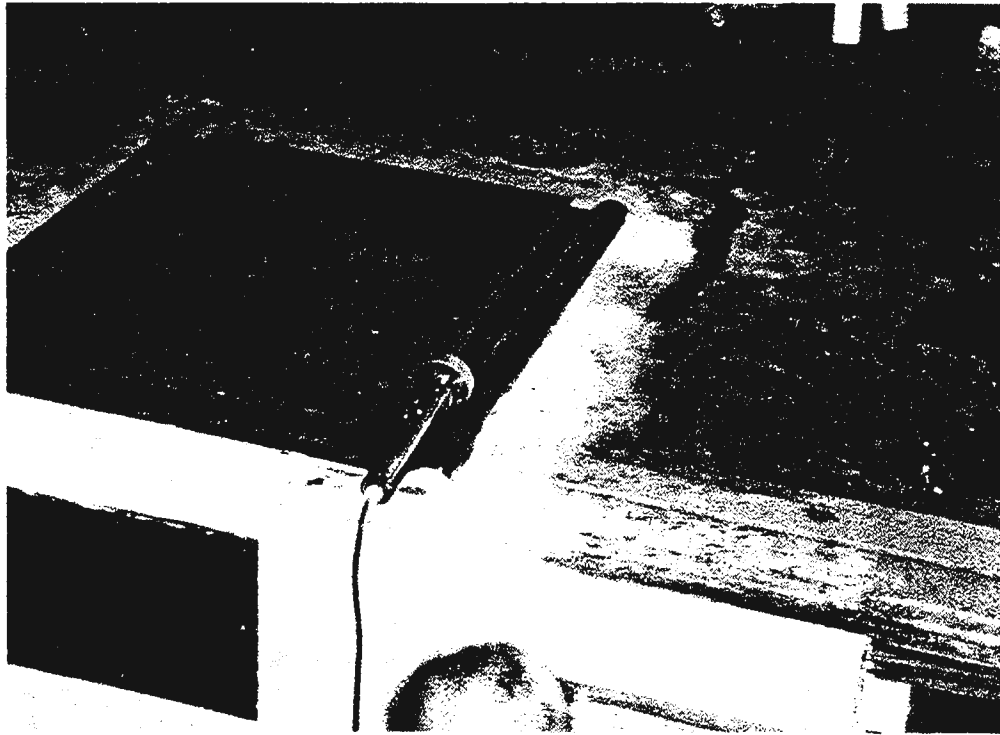

Figure 2.6.3.2.3/ Front End Play Detector Plate and Hand Controller

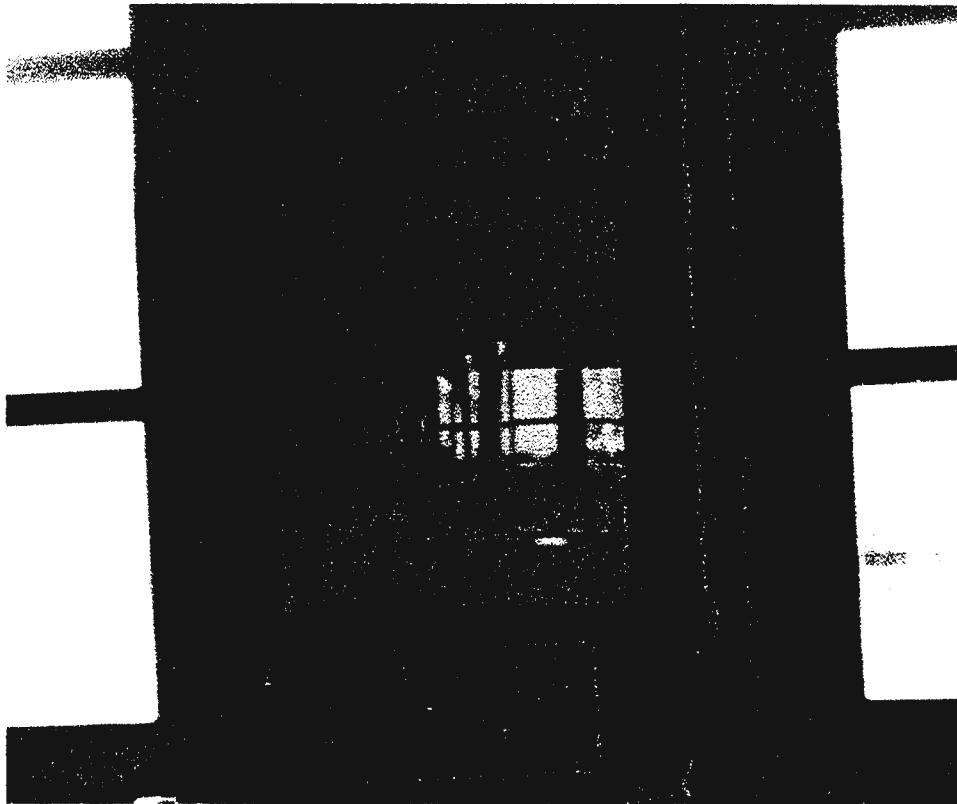
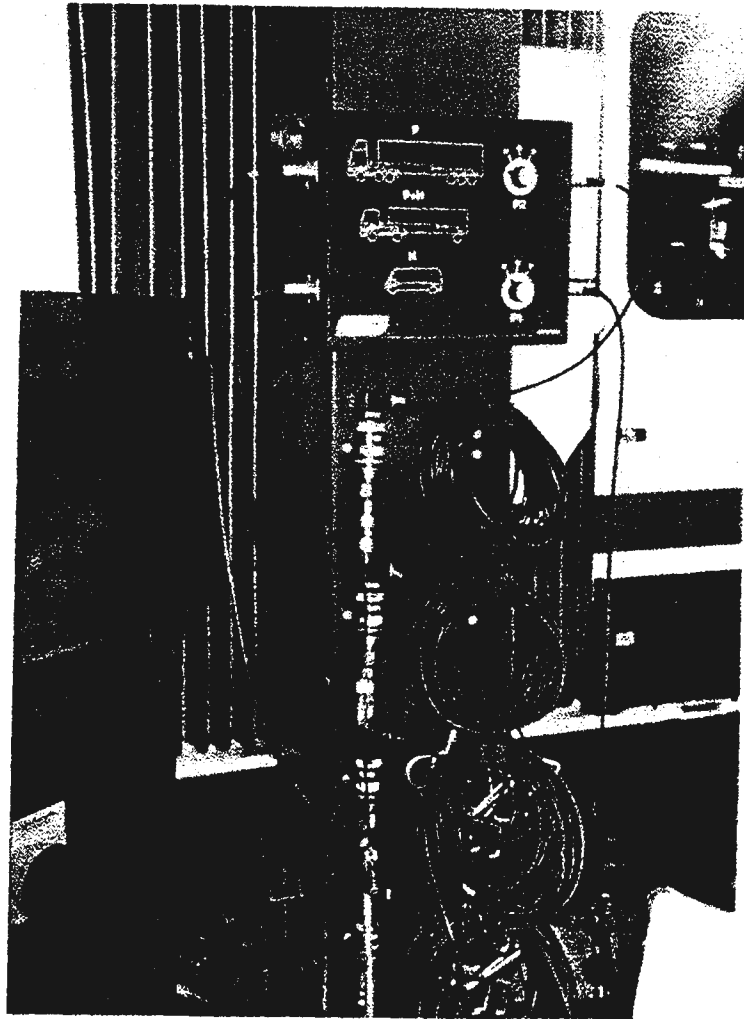

Figure 2.6.3.2.4/ Brake Dyno Analog Display

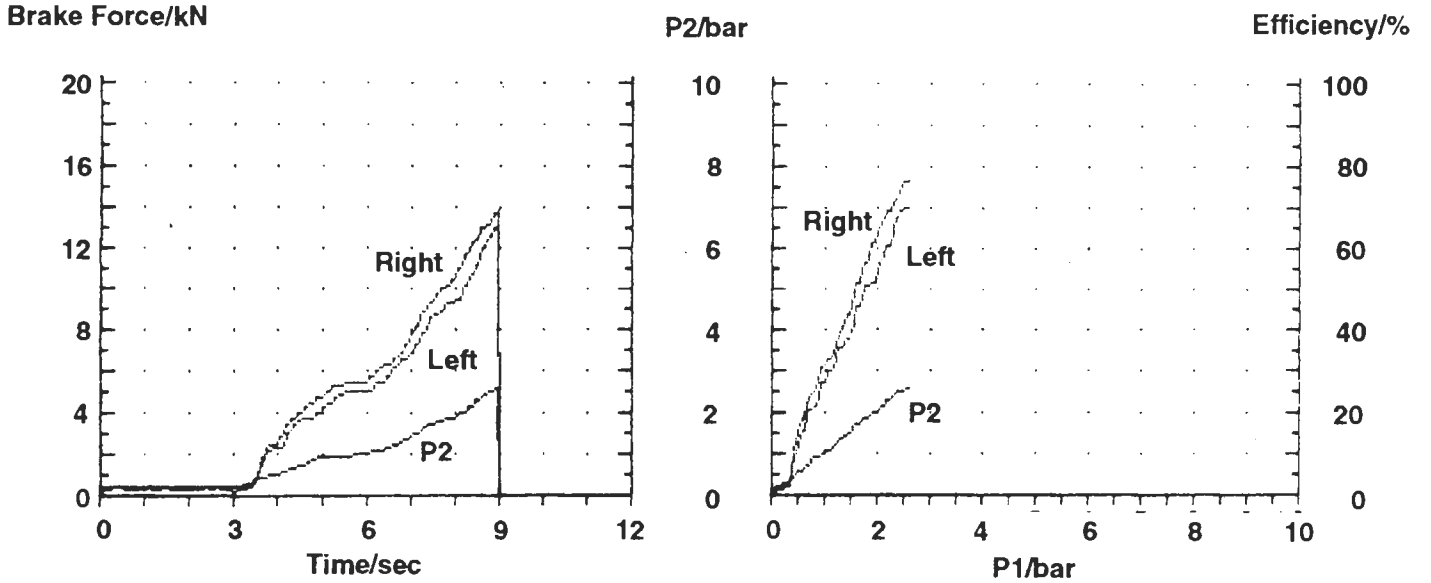

**Figure 2.6.3.2.5/ Brake Dyno - Pressure Transducers
with Cables Clearly Visible**

MAHA Brake Tester

RATP
U.D.O. Depot D'Aubervilliers

1. Service Brake



BRAKE FORCE		VERTICAL FORCE		EFFICIENCY		Pedal Meter 0 N
Left	Right	Left	Right	Left	Right	Pressure P1 2.6 kN
Residual Force		Static		71%	75%	Pressure P2 2.6 kN
0.43 kN	0.60 kN	18.3 kN	18.1 kN	73%		
Maximum		36.4 kN		Difference 5%		
13.44 kN	13.97 kN	Dynamic		Ovality		
27.41 kN		18.8 kN	18.5 kN	--%	--%	
		37.3 kN				

Figure 2.6.3.2.6/ Brake Dyno Test Output

2.6.4/ Paris ORLY-VAL System

The ORLY-VAL system is a derivative of a highly successful train system originally installed in Lille in 1983. The system, which opened on October 2, 1991, carries passengers between the Antony RER station and Orly airport located south of Paris (Figure 2.6.4.1).

The system is a joint venture of private companies: MATRA Transport (the system's designer and builder), RATP, AIR INTER (a French domestic airline), and a consortium of banks. The \$225 million (U.S.) project is structured as a 30-year franchise meant to produce profit for the participants. The project was privately financed, i.e., there was no government subsidy involved. The fare (about \$8 U.S.) is higher than the airport bus, but the travel time to the centre of Paris (30 minutes) is substantially shorter, particularly in peak periods. The joint venture expects initially 4.2 million passengers per year increasing to over 5 million with the opening of the new airport terminal in 1993.

The system has four stations serviced by eight two-car sets of rubber-tired trains (Figure 2.6.4.2) running on a concrete guideway. The system is entirely automatic: there are no drivers or station attendants. Passengers purchase magnetically encoded tickets from automated vending machines (Figure 2.6.4.3) and proceed to the platform. The system is equipped with a platform-edge automatic door, which opens only when the train arrives (platform-edge doors are thought to be the main reason that more than 250 million passengers were carried at Lille accident free).

Passengers board a pleasantly appointed car to arrive 19 minutes later at one of the three stations at Orly airport.

The trains are automatically controlled from the control centre (Figure 2.6.4.4) which is equipped with the usual displays and colour TV monitors connected to cameras in the stations. There is also a two-way voice communication between the passengers, both from the stations and the trains, and the central control.

The control centre is located within the maintenance facility. The maintenance building has a plain concrete floor with two jacking systems permitting the lifting of a two-car train (Figure 2.6.4.5). This permits easy access to the underside and the train's relatively complicated bogies (Figure 2.6.4.6). The maintenance building also stores various service vehicles (Figure 2.6.4.7).

In conclusion, the ORLY-VAL system appears to be efficient. Its financial success will however depend on attracting a sufficient number of passengers who may consider the relatively high fare prohibitive.

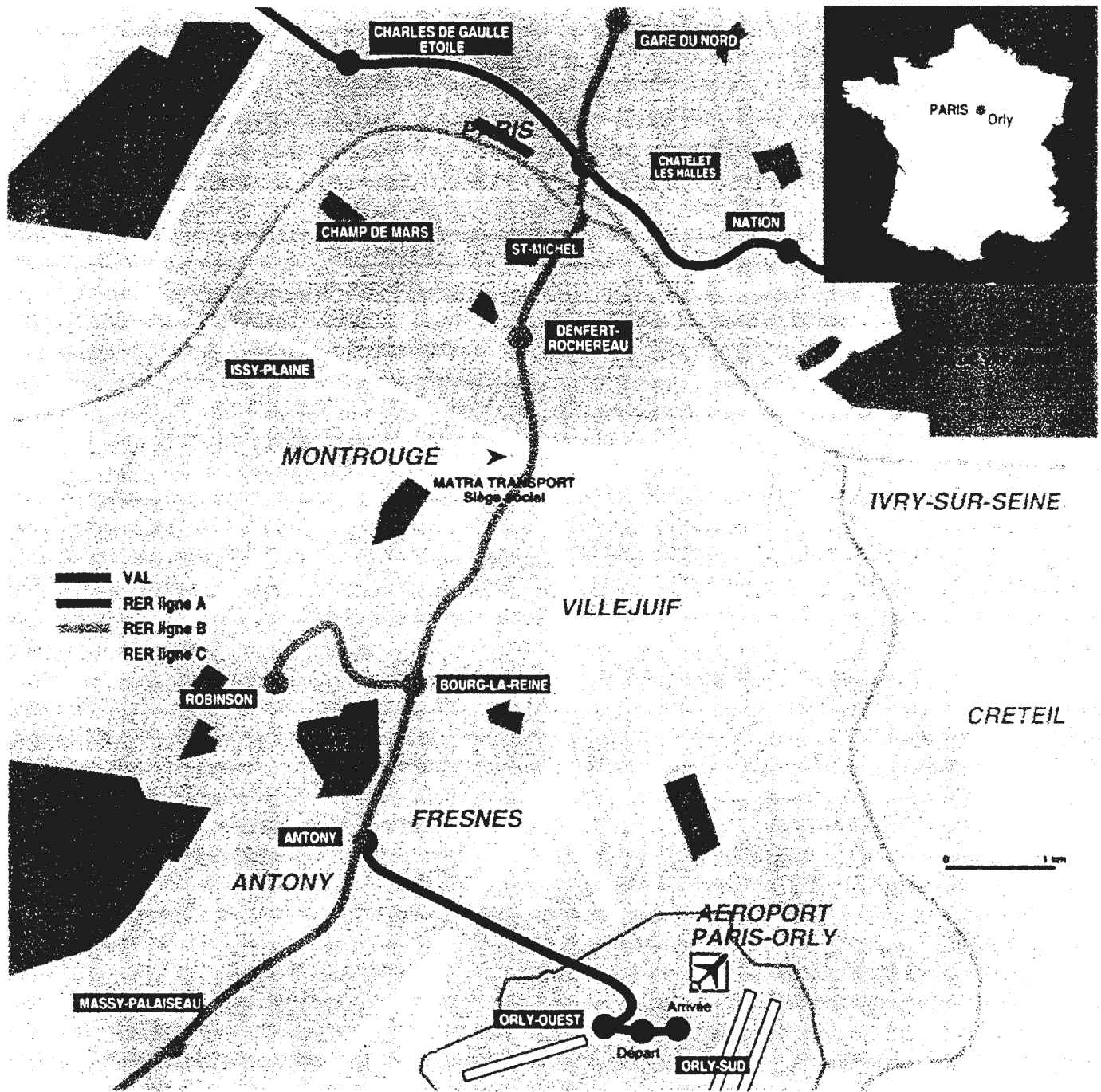

Figure 2.6.4.1/ Map of ORLY-VAL System

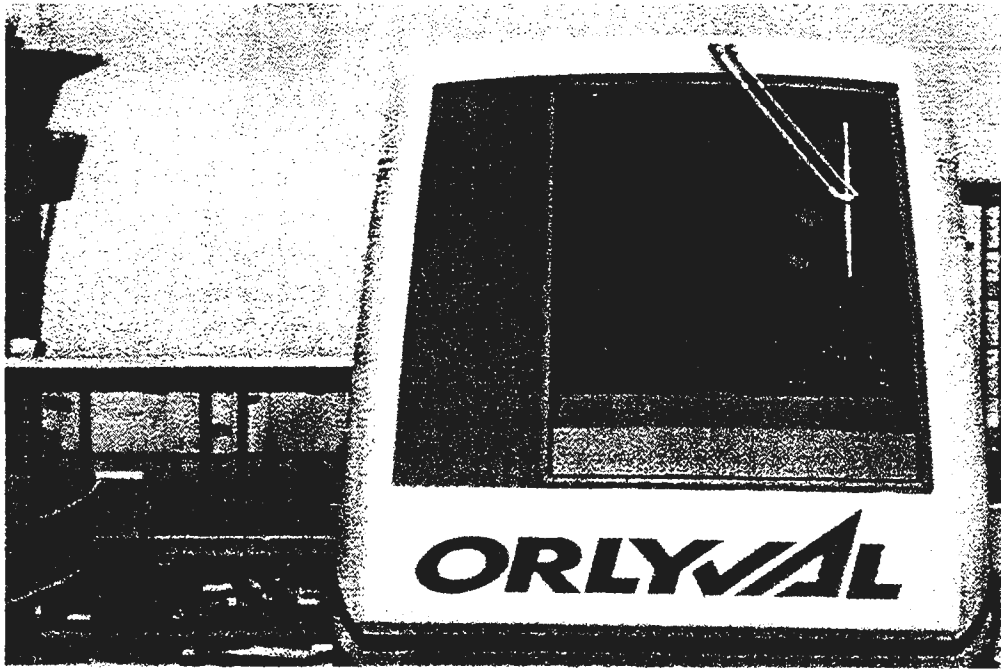

Figure 2.6.4.2/ ORLY-VAL Train

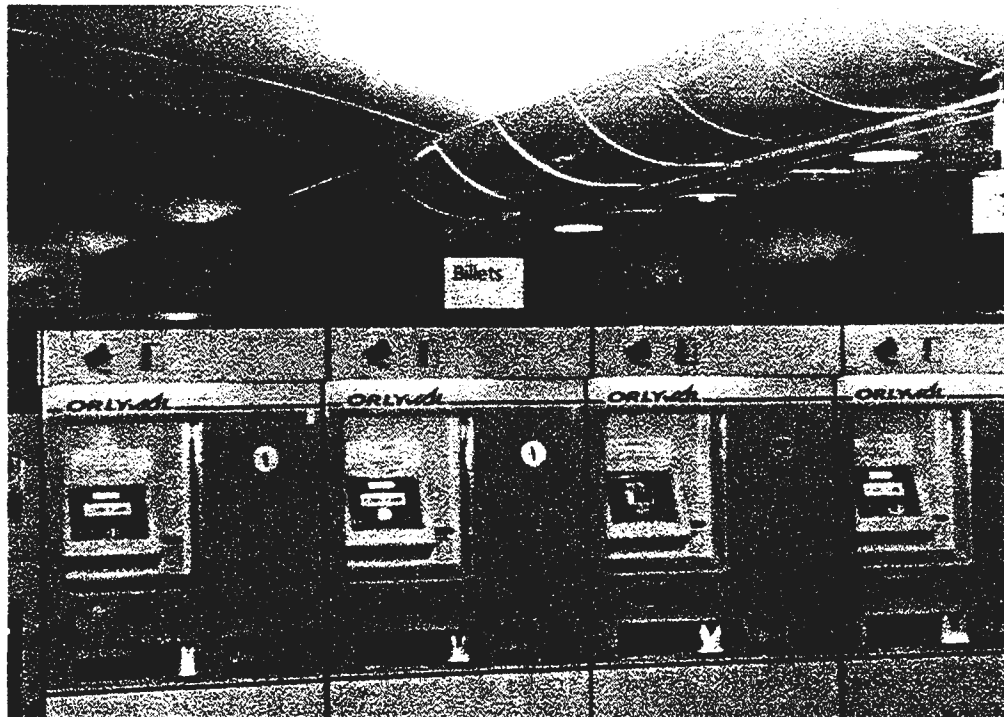

Figure 2.6.4.3/ ORLY-VAL Ticket Dispensing Machines



Figure 2.6.4.4/ ORLY-VAL Control Centre



Figure 2.6.4.5/ ORLY-VAL Jacking System

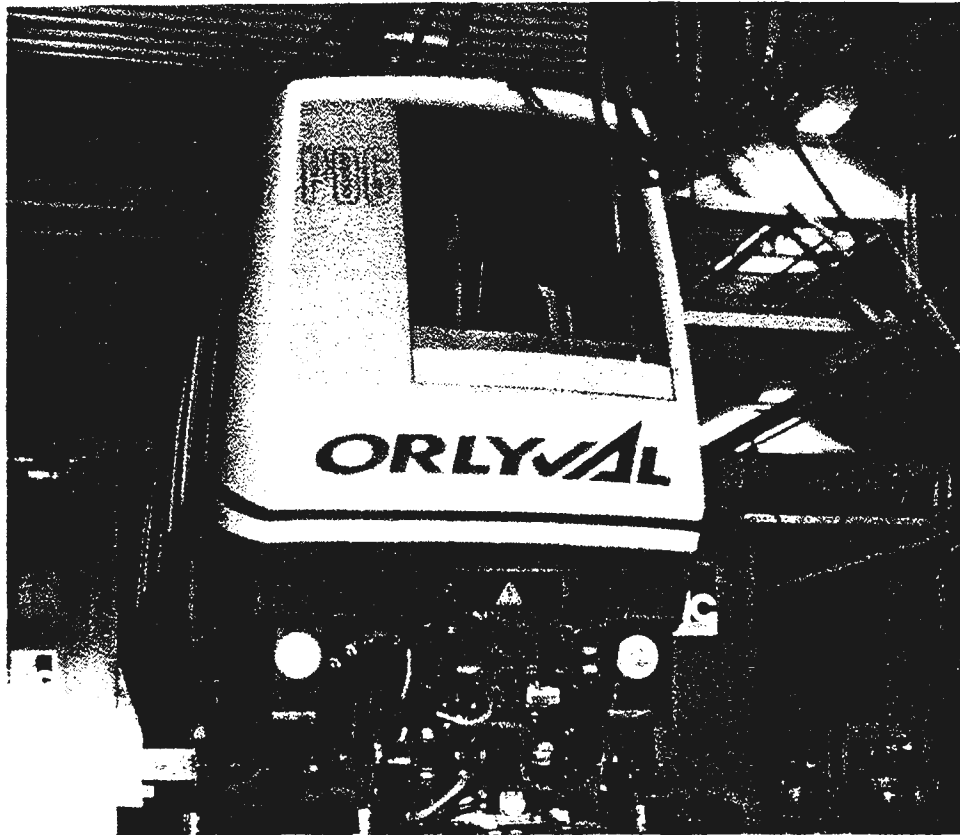

Figure 2.6.4.6/ ORLY-VAL Bogie – Front View

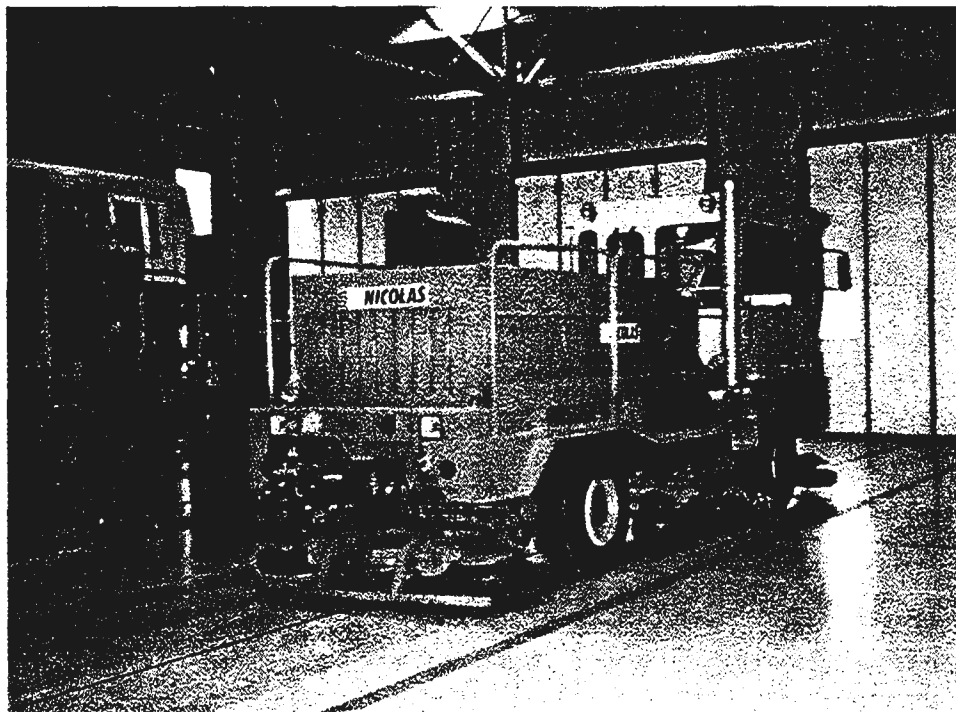

Figure 2.6.4.7/ ORLY-VAL Service Vehicle

2.6.5/ Paris – Robotics

In 1983 RATP decided that robotics would be an answer to the continuous problems they had with the cleaning of the subway network. They felt that they were not getting value for their money from the cleaning department, numbering 1400 at the time. Consequently, they decided to contract system cleaning to a private organization and simultaneously develop human assisted robotic cleaning capabilities, thus decreasing dependence on manual labour. RATP eventually signed a long-term cleaning contract with a company called Comatec and also sponsored development of a mobile cleaning platform which was demonstrated during an international cleaning congress held in Paris in 1984 (Figure 2.6.5.1). This is a programmable floor scrubbing platform developed by a specialized robotic company, Midi Robots, with the assistance of Atomic Energy of France and others. The platform can be programmed to follow any desired trajectory. RATP planned to use such robots during low-traffic periods and, so the prototype was equipped with sonar sensors to detect passengers and other obstacles.

In 1985 a consortium, PROTÉE, was formed jointly by RATP and Comatec. The purpose of the consortium is to develop and build a series of robotized or highly automated equipment to improve the quality and productivity of cleaning the metro system.

The design of the current family of equipment is carried out by a highly specialized company, Robatec, itself owned by a French water utility. The actual equipment manufacturing is handled by others; for example CAMIVA, a part of a Renault consortium, supplies the mechanical portion of the platform.

The present family consists of four basic robots: C.A.B., P.A.T., A2R, and Elfe A. These are briefly described below.

C.A.B. robots come in two different configurations; C.A.B. and C.A.B.X. (Figure 2.6.5.2). They are electrically powered track drive platforms and carry sweeping/suction modules plus a collection of tools usually used by cleaners, such as a hand-held vacuum (Figure 2.6.5.3) or a high pressure washer. Staircases are easily negotiated with the track drive propulsion system (Figure 2.6.5.4). They can be carried on board trains from one station to another. They are basically floor sweepers with rotating brushes that sweep the debris toward the centre where it is vacuumed into a filter-equipped dust bag. This is a high quality machine, and it even includes an automatic, on-board fire extinguisher (Figure 2.6.5.5).

The C.A.B.X. robots can work both in autonomous and manual modes. The autonomous navigation is used for cleaning functions – the area to be cleaned is "mapped" into the memory and the robot follows it with the help of a gyro. Absolute position reference is periodically obtained from magnetic markers imbedded in the floor. The robot is manually moved between work stations using a joystick.

The C.A.B. series is only manually guided. There are reputedly 25 C.A.B. and C.A.B.X. series robots under testing at RATP.

P.A.T. (Figure 2.6.5.6) is a small platform used to transport loads up to 350 kg. As it is equipped with track drive, it is able to negotiate slopes and stairs. The platform is powered by a small combustion engine (propane/butane) and is equipped with a ramp and a winch to facilitate loading and unloading.

The A2R robot (Figure 2.6.5.7) is designed to clean the floor of a subway car. The cleaning is done using two rotating scrubbing brushes and suction. The robot is very small (25 cm high) to fit under the seats, and is hand-carried from car to car. It is designed to work in autonomous mode (the car floor layout is preprogrammed) and is equipped with ultrasonic detection sensors. We did not see this robot in operation and an opinion was expressed that the current model is too delicate to last in the industrial environment in its present form.

The Elfe A robot (Figure 2.6.5.8) is designed to clean walls and ceilings of the RATP stations. It is designed to travel throughout the RATP network on rails and to automatically "lift" itself to the rail platform permitting passage of trains. It has a large, remotely controlled arm with a specially designed system of brushes and water recovery system.

The trip participants had no opportunity to view this equipment, but the author viewed a short film which showed testing of the Elfe prototype.

A short visit was made by the author to Robatec's facility near Paris where robots are being designed and tested.

Due to its ability to climb stairs, the C.A.B. series is quite expensive (Fr 800 000, approximately \$150,000). As such, Robatec is working on several other floor cleaning robots, e.g., a modified floor sweeper shown in Figure 2.6.5.9 and a specially designed machine shown in Figure 2.6.5.10. Robatec has also produced a "dumb" but quite inexpensive robotic floor vacuum machine (Figure 2.6.5.11) and a quite sophisticated glass cleaning system (Figure 2.6.5.12) which is at present used to clean the glass pyramid at the Louvre.

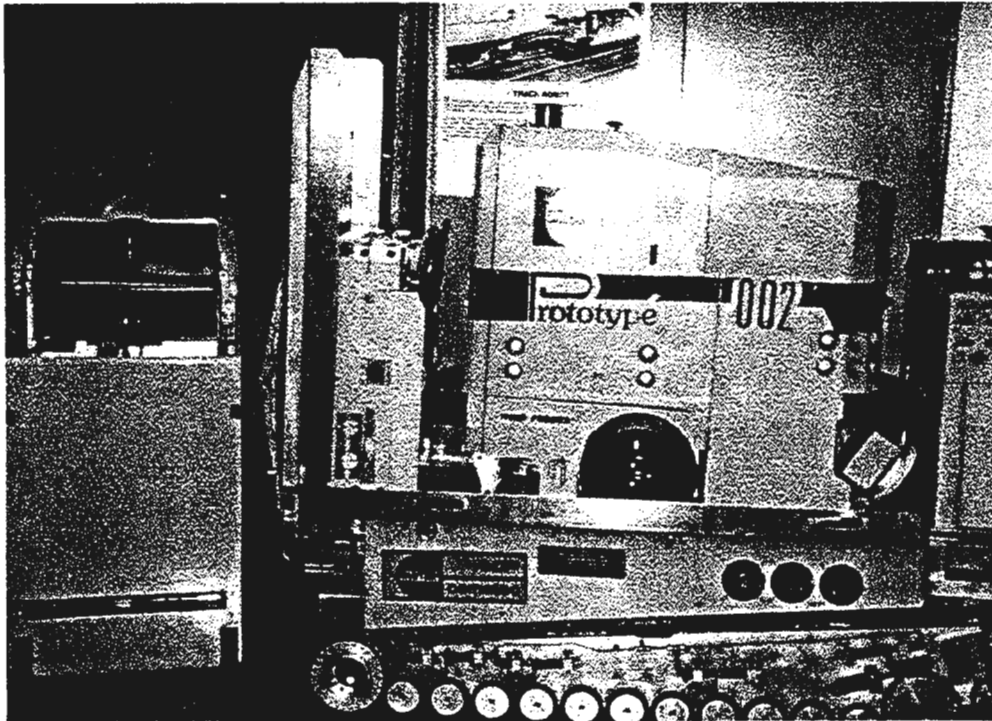

Figure 2.6.5.1/ Prototype of Cleaning Robot by Midi Robots

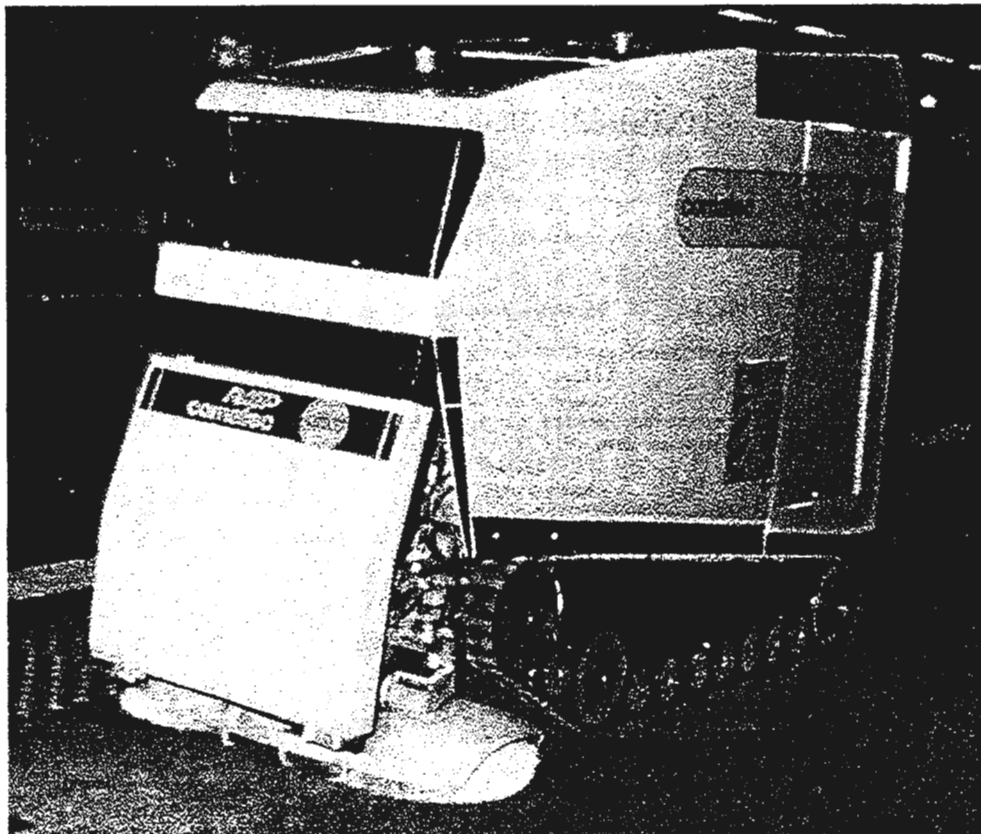

Figure 2.6.5.2/ C.A.B.X. Cleaning Robot

Source: Protée

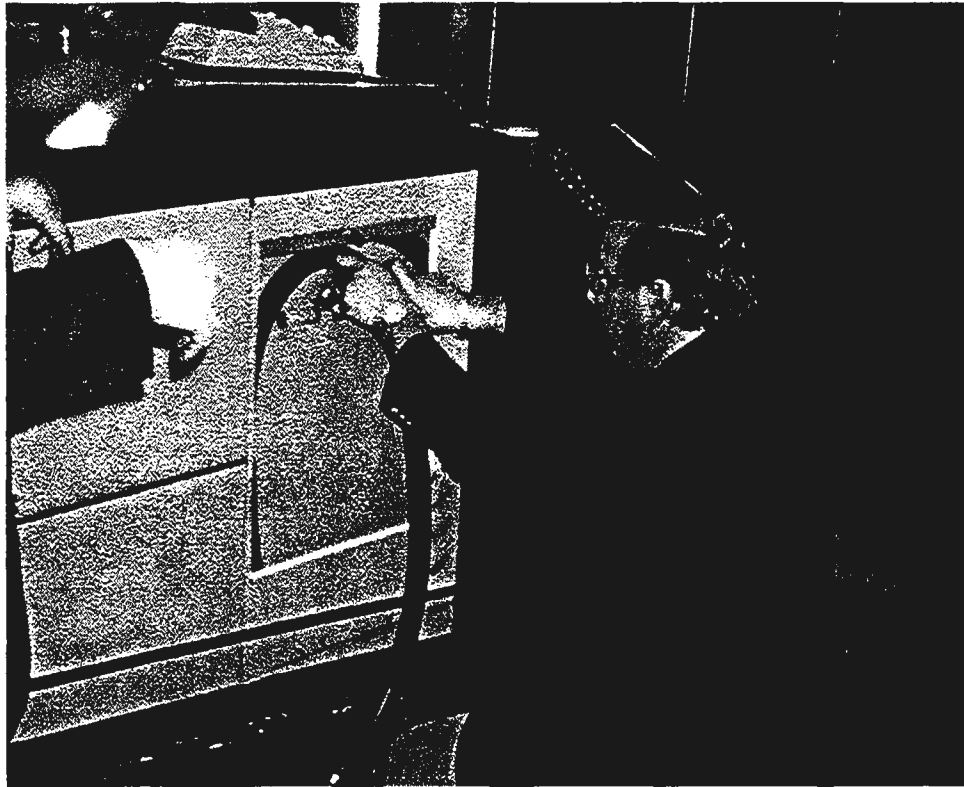

Figure 2.6.5.3/ External Vacuum Hose

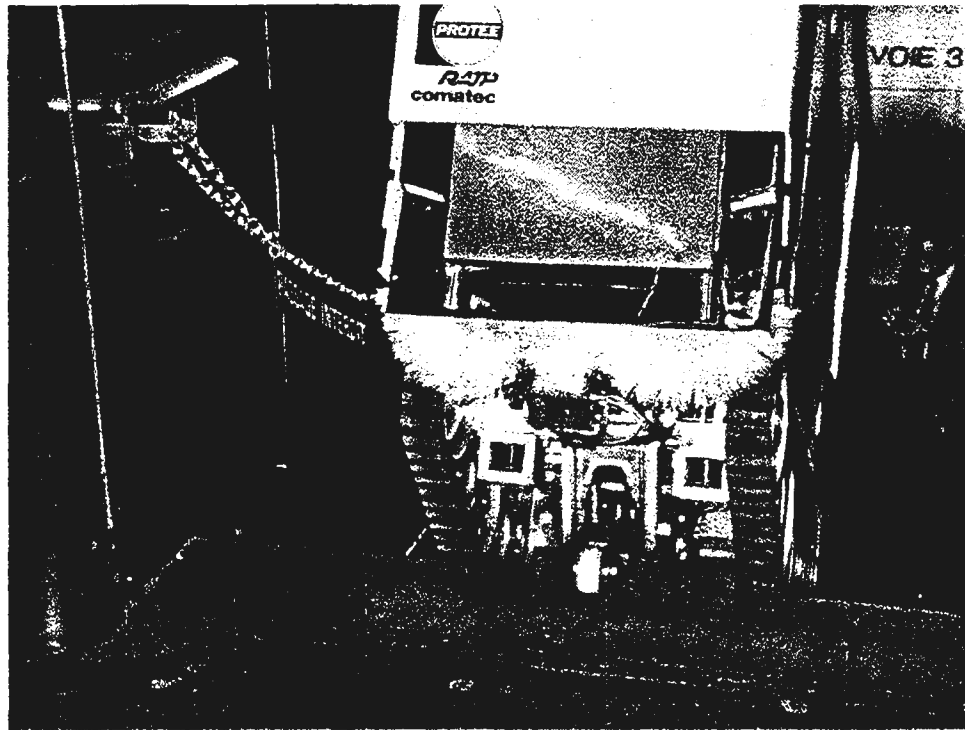

Figure 2.6.5.4/ Robot Climbing Stairs



Figure 2.6.5.5/ C.A.B.X. Debris Collection Area with Fire Extinguishing System

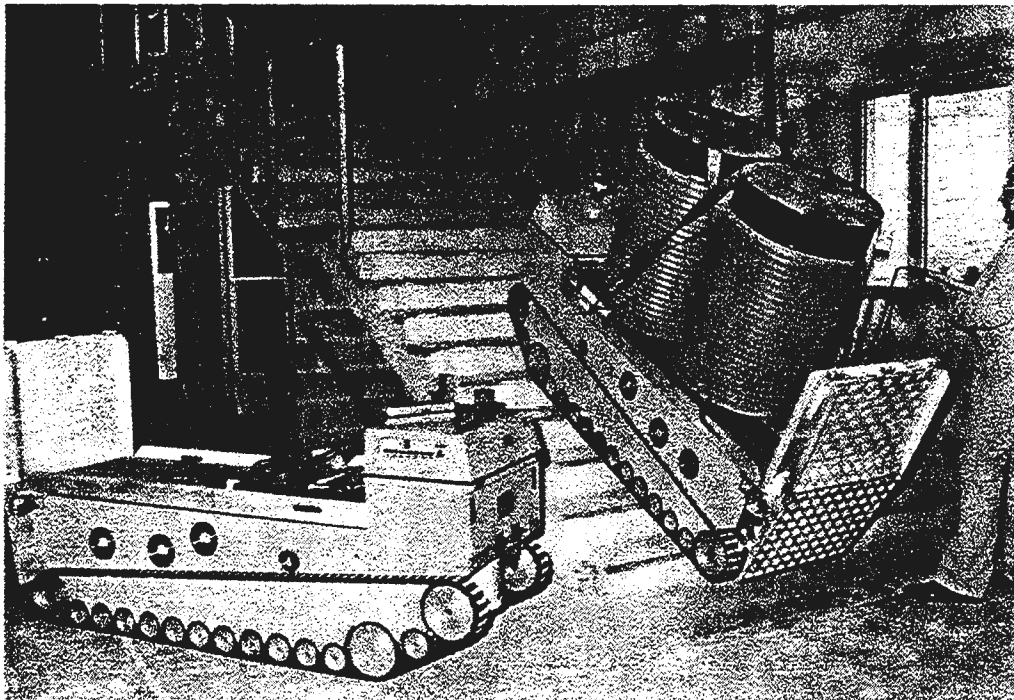

Figure 2.6.5.6/ P.A.T. Tracked Platform

Source: Protée

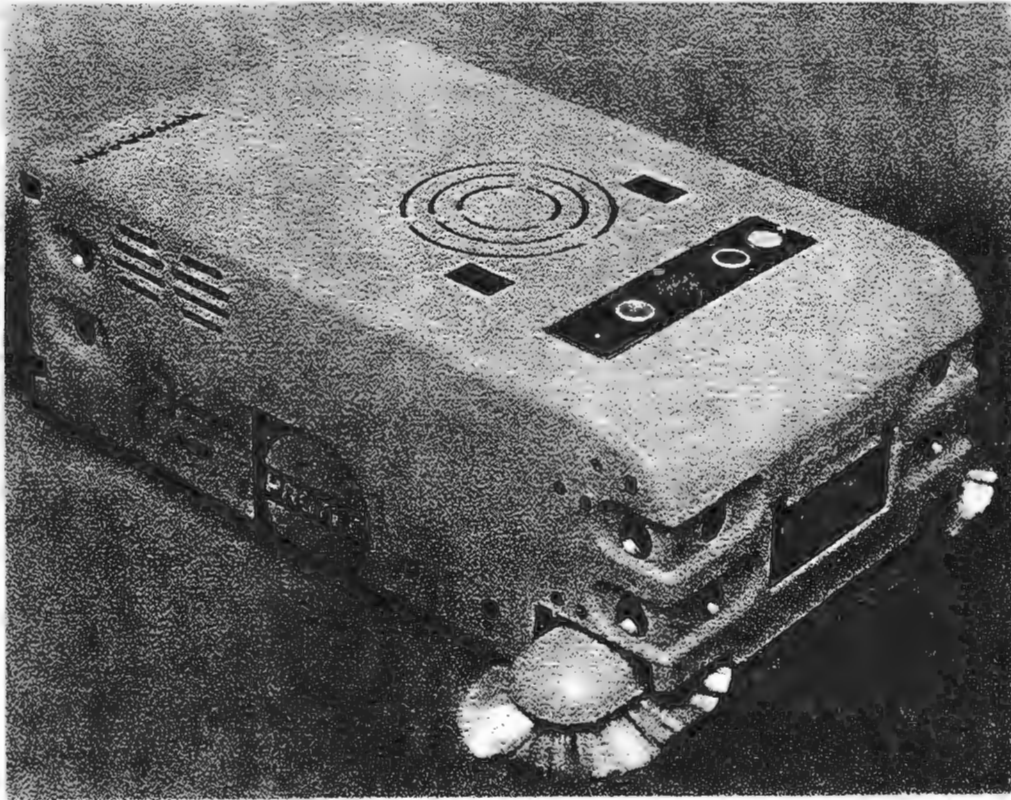

Figure 2.6.5.7/ The Carriage Robot: A2R

Source: Protée

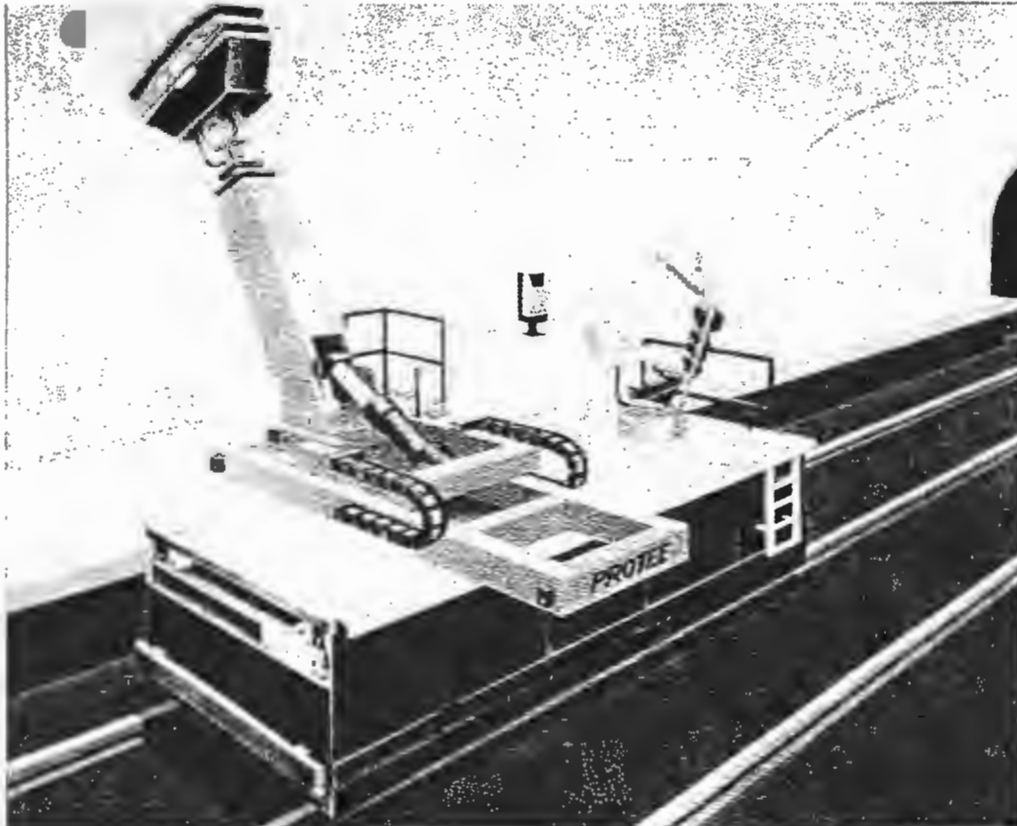

Figure 2.6.5.8/ The Arch Robot: Elfe A

Source: Protée

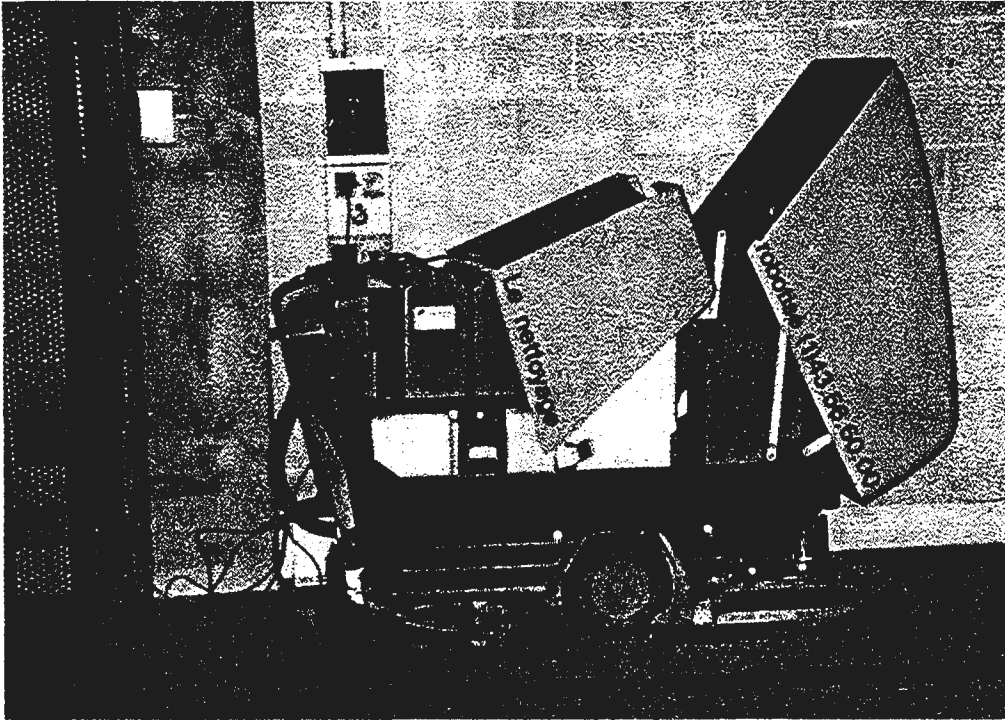

Figure 2.6.5.9/ Floor Cleaning Robot (uses magnetic floor markers for guidance)

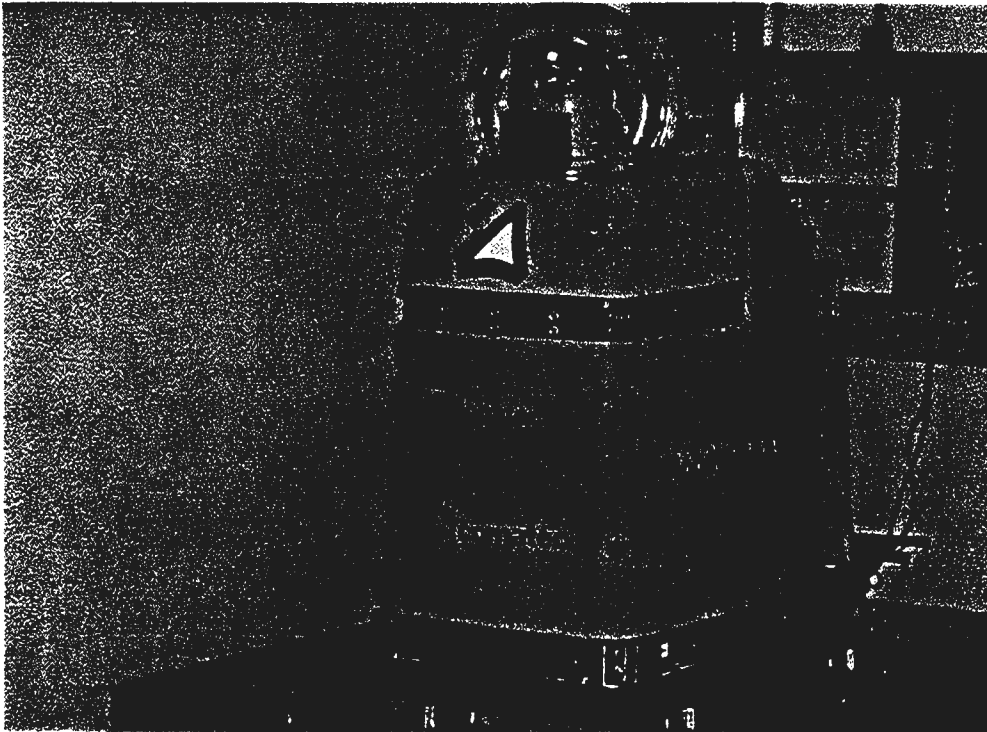

Figure 2.6.5.10/ New Floor Cleaning Prototype (uses infrared guidance technology)

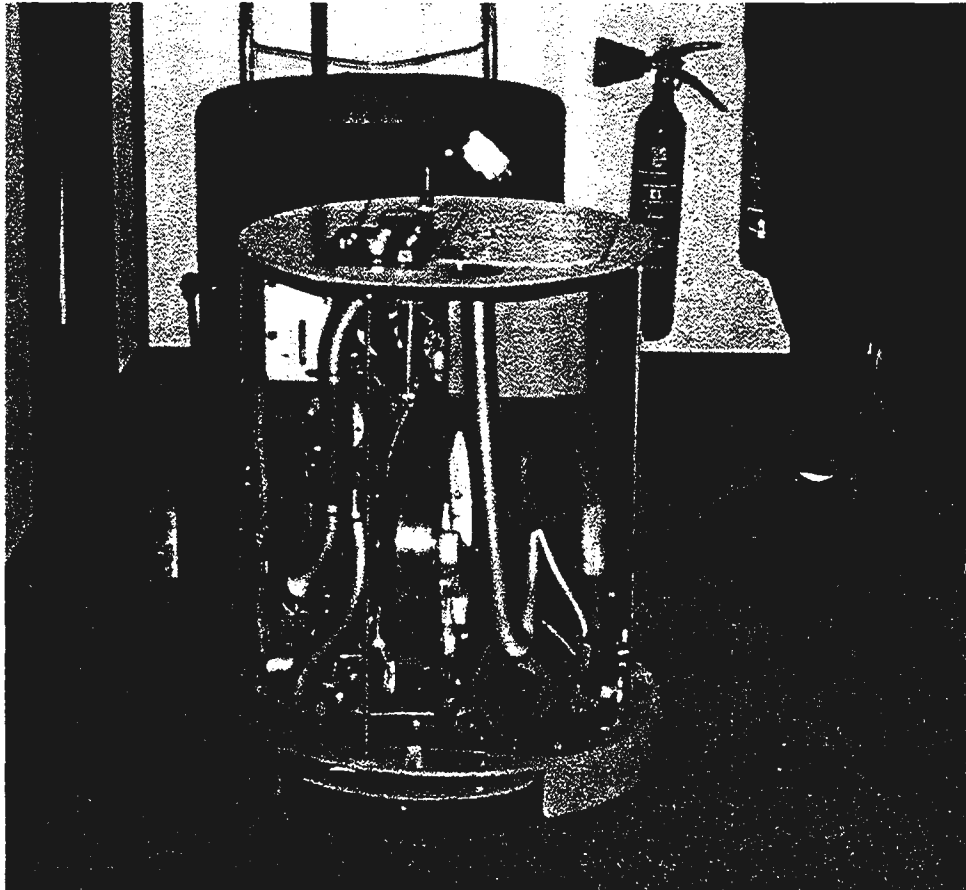

Figure 2.6.5.11/ Vacuum Cleaning Robot

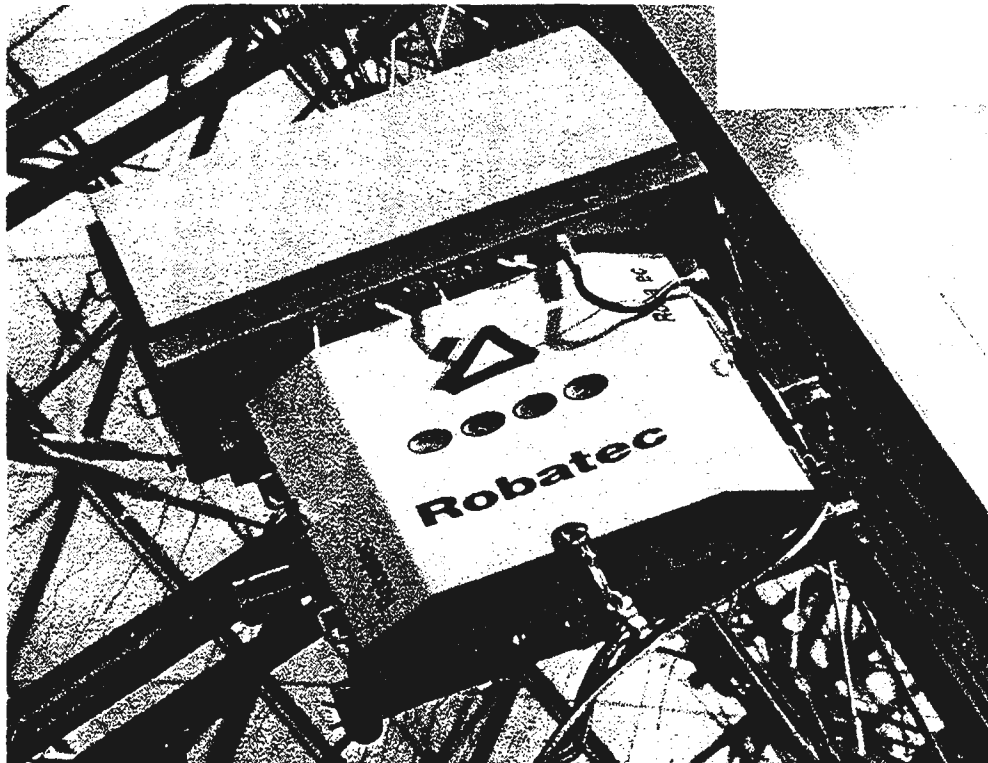

Figure 2.6.5.12/ Window Cleaning Robot

Source: Robatec

3/ SOCIÉTÉ DES TRANSPORTS EN COMMUN DE L'AGGLOMÉRATION DE BAYONNE (STAB) – BAYONNE COMMUNITY PUBLIC TRANSPORT ASSOCIATION

3.1/ General Description

STAB provides bus service to three cities: Bayonne, Biarritz, and Anglet which together form a mini-metropolis. The buses (79 at the time of the visit), buildings, and equipment are owned by the municipality, which tenders the actual running of the system to a private, profit-making organization.

The transit system is located in an all-new facility (Figure 3.1.1) which was completed approximately one year before the visit at a cost of 35 million French francs (approximately \$6.45M Canadian). The facility houses the administration and the maintenance areas. The robotic fuelling station (Figure 3.1.2) is located outside as is the washer. The driver simply stops at the fuelling station and later parks the bus in its assigned space outside in a covered parking area (Figure 3.1.3). The interior of the bus is vacuumed by a cleaner (Figure 3.1.4) who plugs a light-weight hose into the curb receptacle (Figure 3.1.5). There is no nightly service line, because the buses are already fuelled, there is no cash on board, and there is no need to check fluids as the buses are equipped with health-monitoring devices.

The buses are equipped with an inexpensive Automatic Vehicle Location and Control (AVLC) system (Figure 3.1.6) which consists of a digital radio, electronic data storage, and driver display. The memory is large enough to accommodate an entire fleet's schedule, which is downloaded via radio when required. The driver logs on by entering his or her ID and route number.

The computer uses an odometer reading, time, and on-board schedule to advise the driver if he or she is on time, fast, or slow. The same system activates on-board passenger displays. Each individual bus's odometer correction factor, used to correct for the vehicle's tire wear, is recalculated every three months by driving the bus through a marked distance (250 m) and pushing two buttons. The property owns 25 battery operated sign posts which are moved around the city and record bus passage. This data is used by a computer program for periodic schedule adjustments which are then radio downloaded to all buses.

The building systems (temperature, lights, air, etc.) are controlled by a simple IBM compatible microcomputer which presents information in either a simple textual or graphical format.

The property is remarkably free of paperwork with the exception of outside correspondence or unless required by law, e.g., a driver's schedule. It is however interesting that a driver can access his or her schedule from a home phone and even change it in real time, e.g., to book sick.

The property is capable of major maintenance work including body rebuilds (Figure 3.1.7), but not painting. The administration and maintenance areas are bright and airy.

The building has the usual lifts and pits and is capable of accommodating both articulated and standard buses in the same service lanes by means of, for example, a moveable exhaust system (Figure 3.1.8). As the property is run for profit, they do not mind getting suitable engines from scrap or permitting their washer to be used by outside parties for a fee.

The personnel appear to be enthusiastic, well educated, and well paid. The total personnel number is well below what is expected at a North American transit property of comparable size.

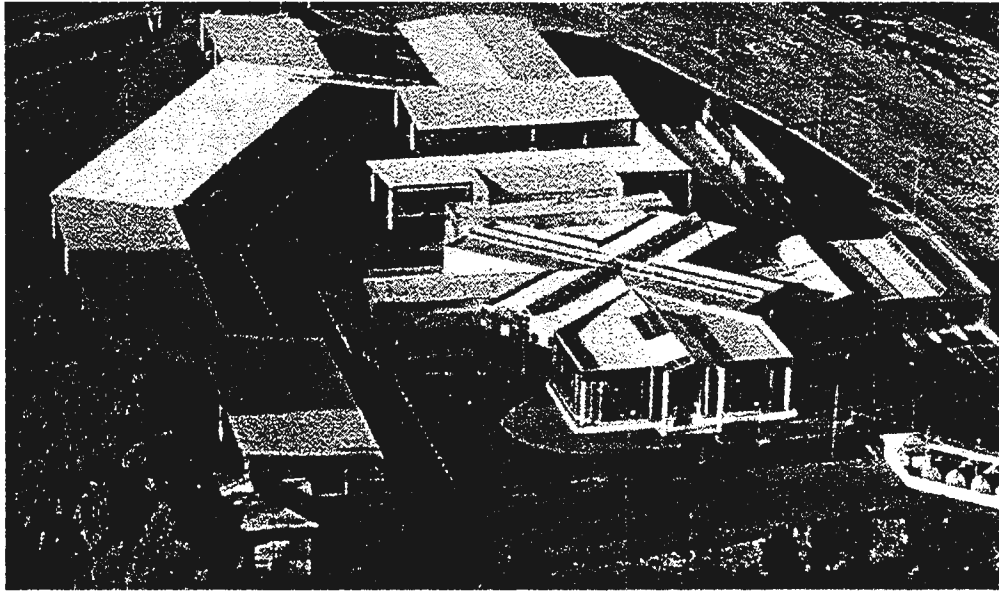

Figure 3.1.1/ STAB Facility – Aerial View

Source: STAB



Figure 3.1.2/ Robotic Fuelling Lane



Figure 3.1.3/ Outdoor Garage



Figure 3.1.4/ Cleaning the Interior of the Bus

Source: STAB



Figure 3.1.5/ Curb-style Vacuum Receptacle



Figure 3.1.6/ AVL System



Figure 3.1.7/ STAB Bus Refurbishing

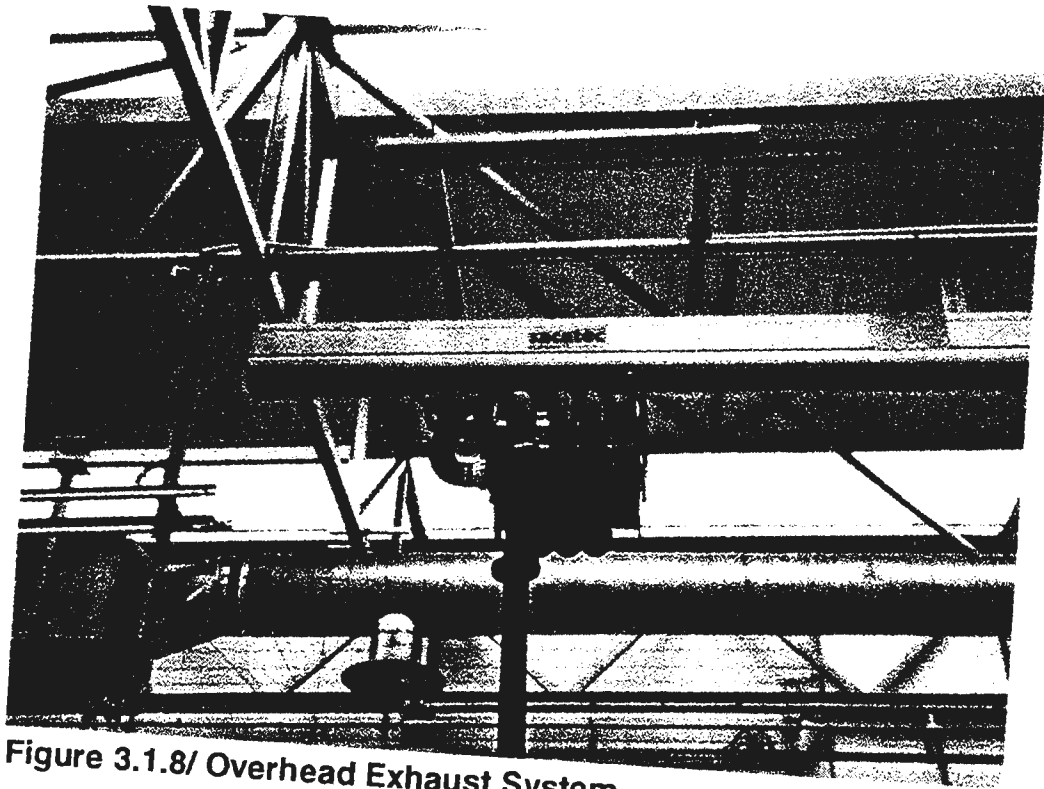

Figure 3.1.8/ Overhead Exhaust System

3.2/ OSCAR Fuelling Robot

In the mid-1980s, RATP commissioned the building of a prototype of a robotic fuelling station (Figure 3.2.1). The equipment was designed for very liberal parking tolerances and consequently used a large suspended robotic arm. The fuel inlet was detected by a vision camera. The project, although technically successful, did not proceed to commercial implementation mainly due to the high cost, FF 800 000 (\$147,000 Cdn.) and some problems with unions.

The OSCAR robot was developed in a partnership between the Bayonne (80 buses) and Toulouse (500 buses) transit organizations. The proposal was issued at the end of 1989 and the prototype was available in early 1990. It was installed in Bayonne in August 1990 and the last modification was completed in June 1991.

The second robot was installed in Toulouse in September 1991, and both appear to be working very well, with high reliability.

At the time of the visit, November 1991, Toulouse had a second robot on order and about 100 buses converted (with special fuel inlets). They expect to have five or six robot fuelling lanes. At the time of our visit, the co-owners, Bayonne and Toulouse, were considering commercialization and truck fuelling and were expecting about 15 orders from other transit authorities.

The total development cost was Fr 2 million (\$368,000 Cdn.) and two commercial companies were involved (one for mechanical and one for control work).

The cost of the robot is expected to be Fr 300 000 (\$55,000 Cdn.) installed, with lane modification costs in the Fr 20 000 to 50 000 range (\$3700 to \$9200 Cdn.). Vehicle modification will cost Fr 2500 to Fr 3500 (\$450 to \$640 Cdn.) depending on the type of fuelling mode required (spring loaded push type or magnetic lock). The conversion time would be 2 - 3 hours/vehicle or one person converting four to five vehicles per day.

While the above costs are much lower than the original Paris robot's cost, it should be noted that the specifications for bus parking are more restrictive. The bus is channelled between two concrete islands and its position is also fixed by an indentation that holds the front wheel. This set-up requires much less reach and hence a much simpler robot. Furthermore, the standard diesel fuelling pump is left unchanged and the robot simply "delivers" the regular fuel nozzle. These simplifications have resulted in a much cheaper design.

The additional requirement specified to developers was that the average total fuelling time should not exceed 2.5 minutes. Manual fuelling takes 4.5 minutes: that is, the driver gets out, fuels the vehicle, and notes the amount of fuel and the mileage,

assuming that the average bus requires 110 litres of fuel daily. The tank capacity is 200 litres.

The main elements of the fuelling station are shown in Figure 3.2.2. The robot (3) with the nozzle assembly travels along the track and the nozzle assembly can move vertically and toward the bus. The bus presence is detected by sensors at posts (2) located at the beginning and at the end of the island. There is an additional magnetic sensor in the nozzle assembly which detects the bus fuel inlet. The robot carries the fuel pipe from the pump (4) along an overhead track (5). All the controls are in a separate box (1).

A view of the fuelling bay is shown in Figure 3.2.3. Figure 3.2.4 shows the robot from the bus side and Figure 3.2.5 shows the robot fuelling a bus.

Figure 3.2.6 shows the standard "push in" fuel inlet on the bus – there is a "marker" around the plastic nozzle which is detected by the robot.

Figure 3.2.7 shows the front wheel locator (equipped with magnetic presence sensor). The buses are equipped with short range inductive tags that identify the individual vehicle thus providing an initial position for the robot.

The driver input panel (where the driver enters mileage) is shown in Figure 3.2.8.

Our observations indicated that the robot requires perhaps 20 seconds, in addition to fuel flow time, to complete the entire fuelling operation.

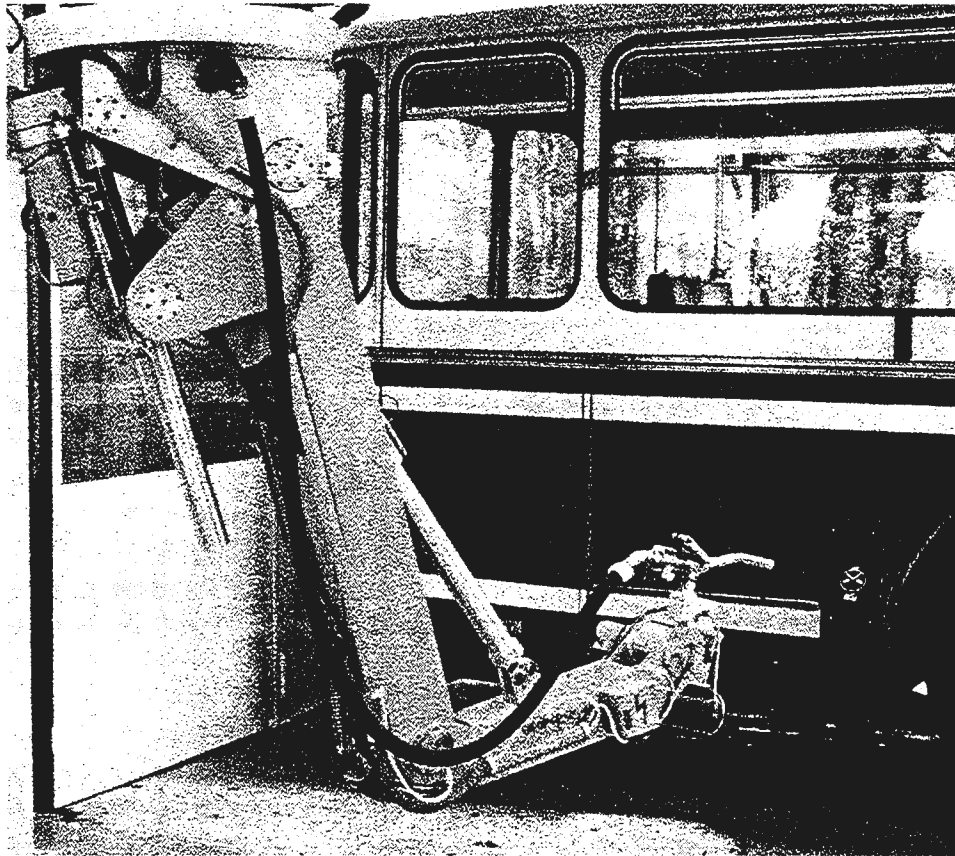
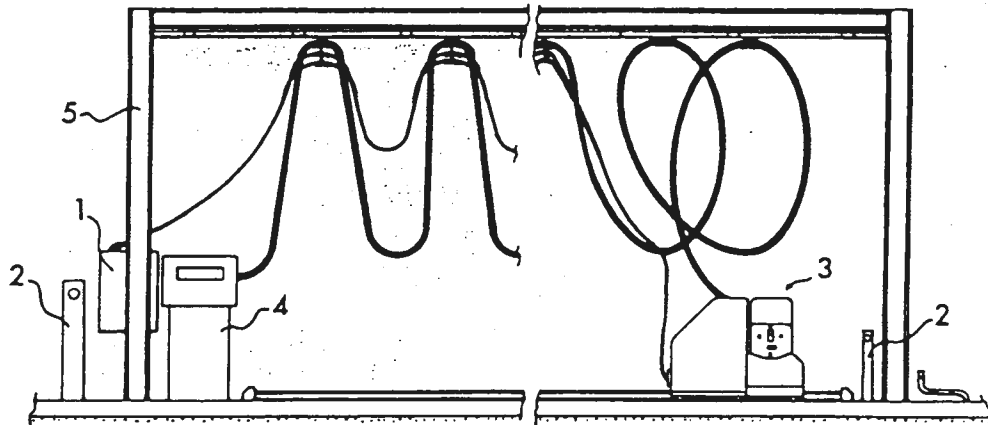

Figure 3.2.1/ Original RATP Fuelling Robot

Source: Alcatel



Source: Semvat and STAB

Figure 3.2.2/ Schematic Layout of OSCAR Fuelling Robot



Figure 3.2.3/ View of Robotic Fuelling Bay

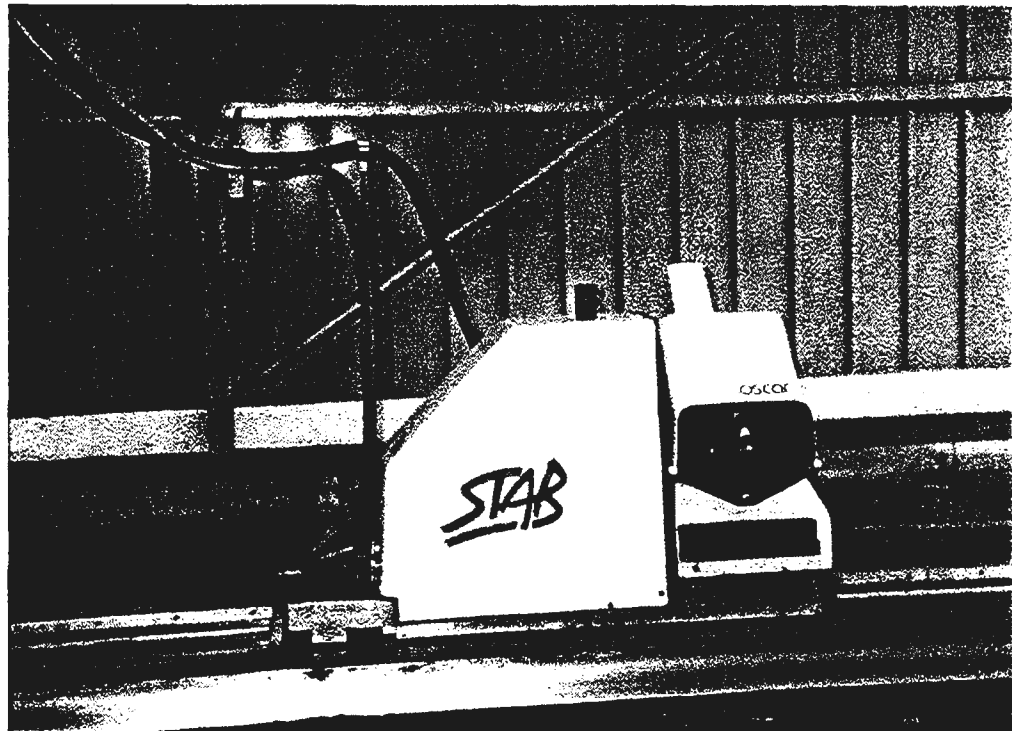

Figure 3.2.4/ View of OSCAR Robot from Bus Side



**Figure 3.2.5/ Side View of OSCAR Robot
Fuelling a Bus**

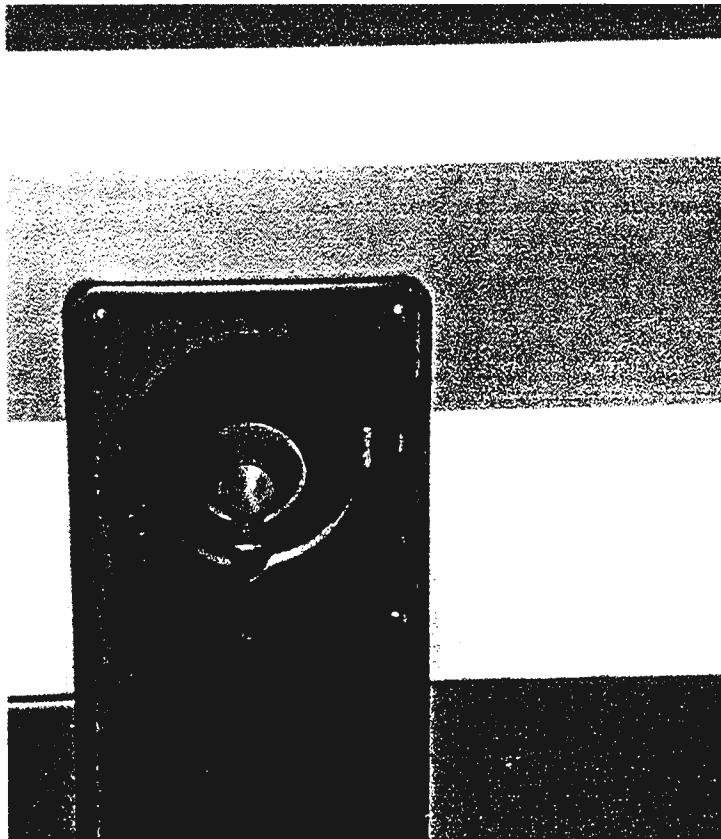

Figure 3.2.6/ Gas Nozzle Receptacle

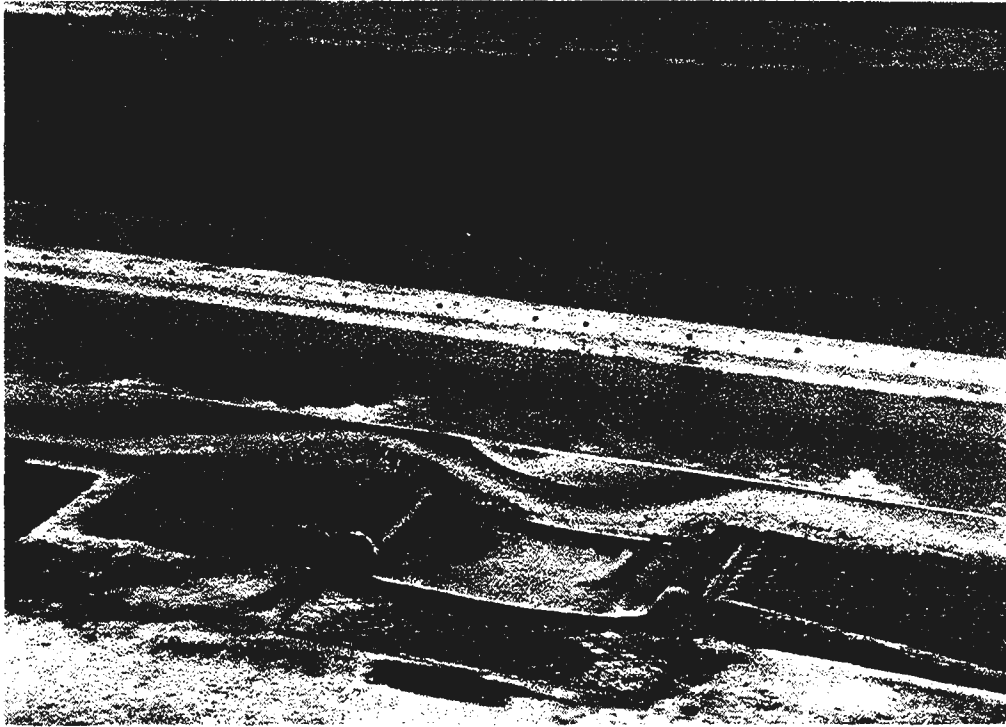

Figure 3.2.7/ Custom Design Wheel Well Used as Part of Robotic Fuelling Station

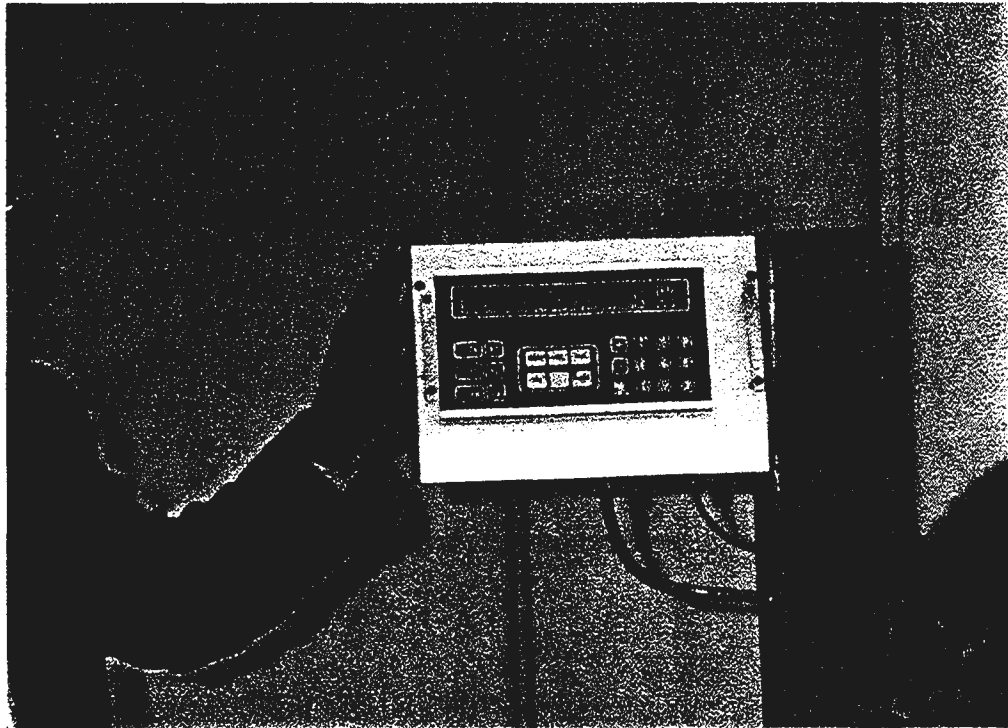

Figure 3.2.8/ Bus/Driver Information Input Panel

4/ TARBES, FRANCE

A brief visit was made to the company, SEP, in Tarbes. The company produces a variety of heavy-duty quality machinery for installing hydro poles, digging under roads, pulling wires, etc.

The purpose of the visit was to examine their road cone machine model Baliseur B240C (Figures 4.1 and 4.2). The machine can be used for automatic positioning and/or retrieval of standard European traffic cones. The operations of the machine are programmed and controlled from inside the cab by a single driver/operator using the panel shown in Figure 4.3. This improves productivity, makes work pleasant for the operator, and increases the safety both of the operator and the cone users.

The machine stores 240 cones in 10 vertical rotating cylinders (Figure 4.4), enough to produce an 8 km line. The operations and cone spacing is programmable and nine operating modes are permitted:

- 1/ Left side positioning.
- 2/ Right side positioning.
- 3/ Left side retrieval.
- 4/ Right side retrieval.
- 5/ Simultaneous left side retrieval and left side positioning.
- 6/ Simultaneous left side retrieval and right side positioning.
- 7/ Simultaneous right side retrieval and right side positioning.
- 8/ Simultaneous right side retrieval and left side positioning.
- 9/ Simultaneous right and left side positioning.

The average operating speed is 18 km/h. The machine is built on a standard 5-tonne Renault truck chassis but can use alternatives. The cones are picked up by a system shown in Figure 4.5 and lifted up for storage by a chain arrangement shown on the right. The deployment system is shown in Figure 4.6.

The product quality appears to be very high with easy maintenance, corrosion protection, etc. The equipment is designed to work in a temperature range of -15°C to +60°C.

We briefly discussed with the designer modifications that would be required to adapt the machine to North American cones. They noted that there are both dimensional and material differences between the two.

Comparison with California cones show (Figure 4.7) the European cone is slightly larger and is made from much harder material. Consequently, it was their feeling that it would take a bit of experimenting to adjust various dimensions in order to get the system to work reliably.

The cost of the equipment is in the range of Fr 800 000 (\$147,000 Cdn.).

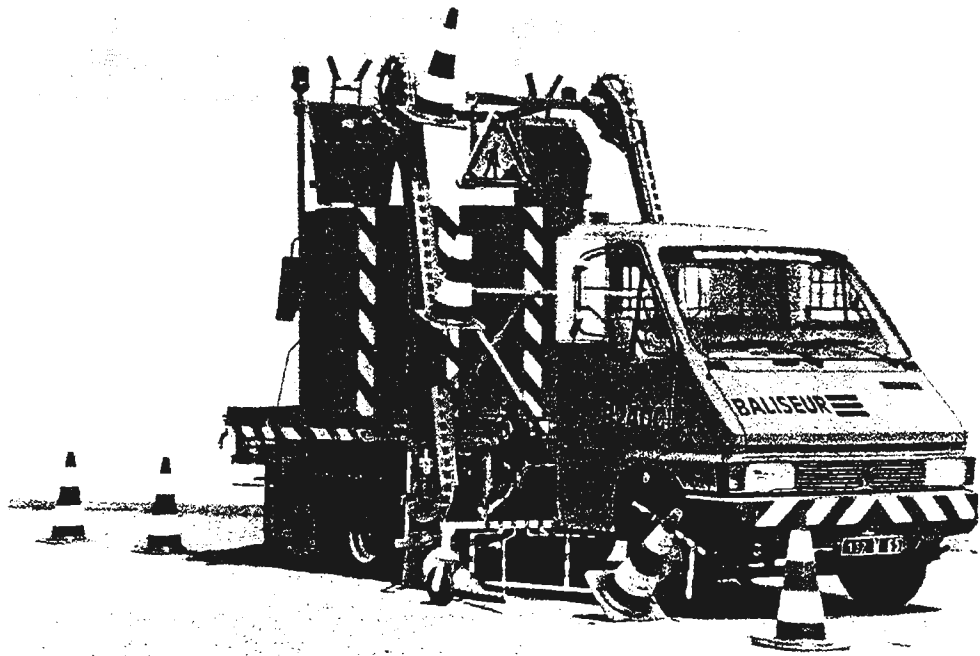

Figure 4.1/ Cone Machine – Right Side

Source: SEP



Figure 4.2/ Cone Machine – Driver's Side

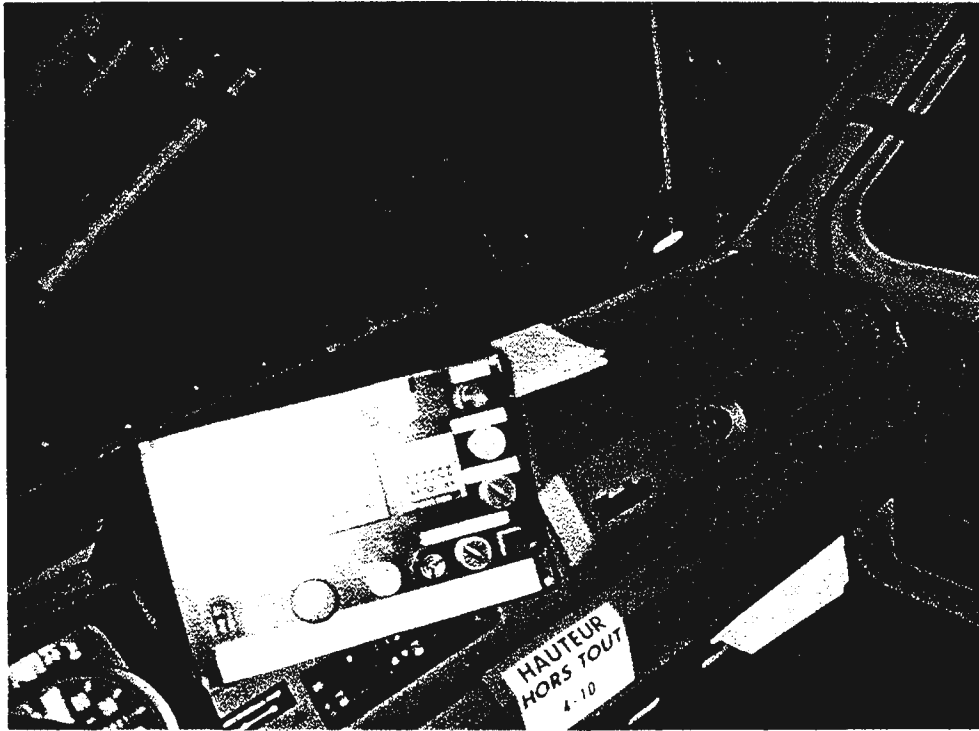

Figure 4.3/ Cone Machine – Control Panel

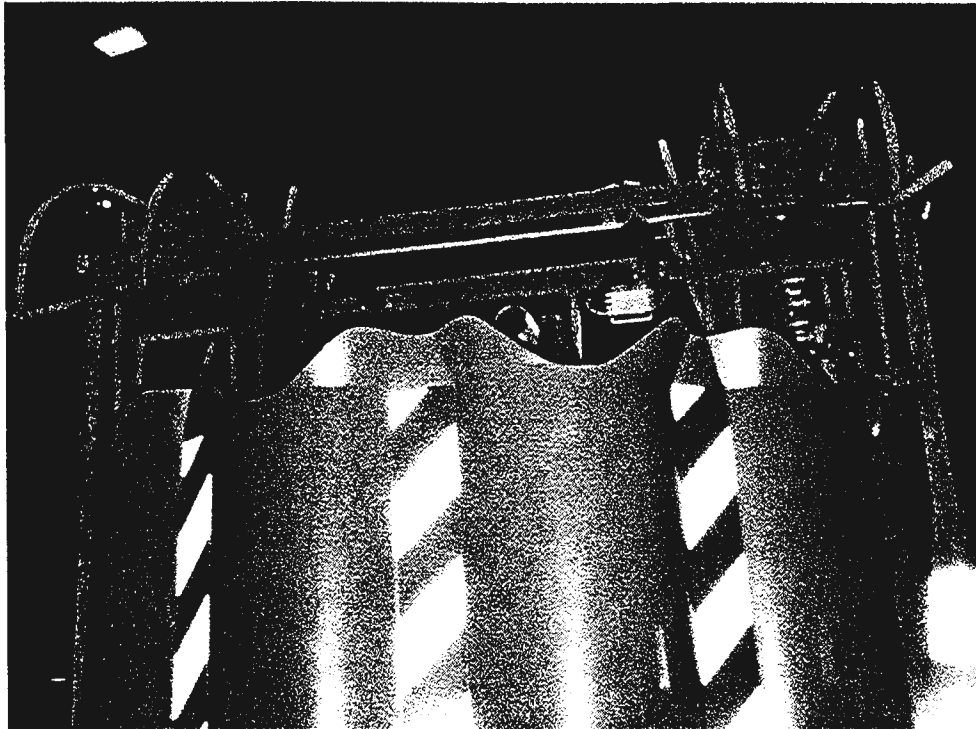

Figure 4.4/ Close-up View of Cone Bins

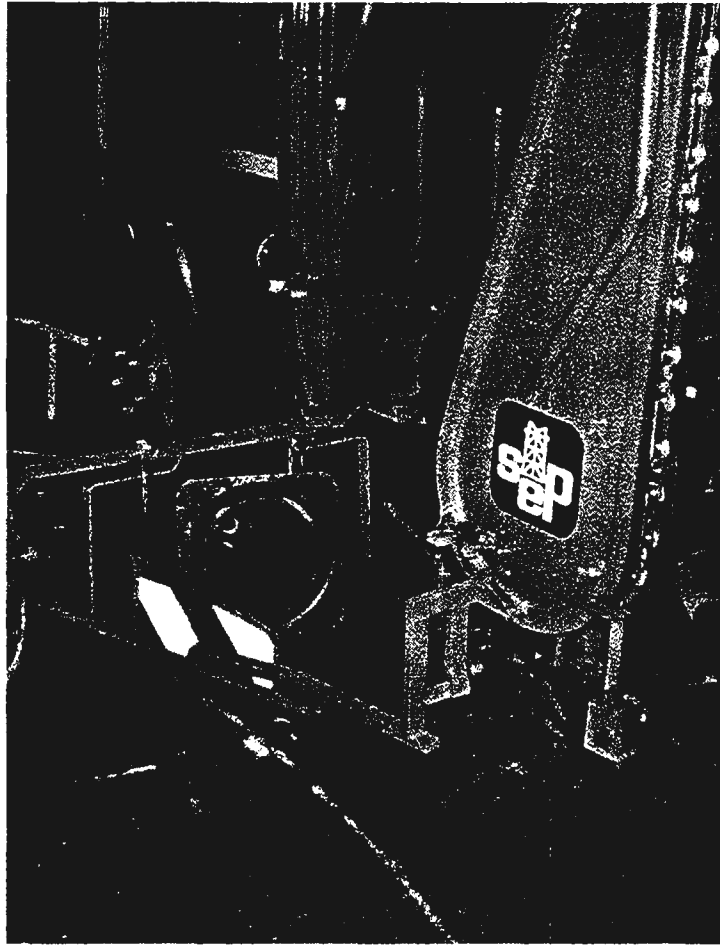

Figure 4.5/ Cone Collection Mechanism

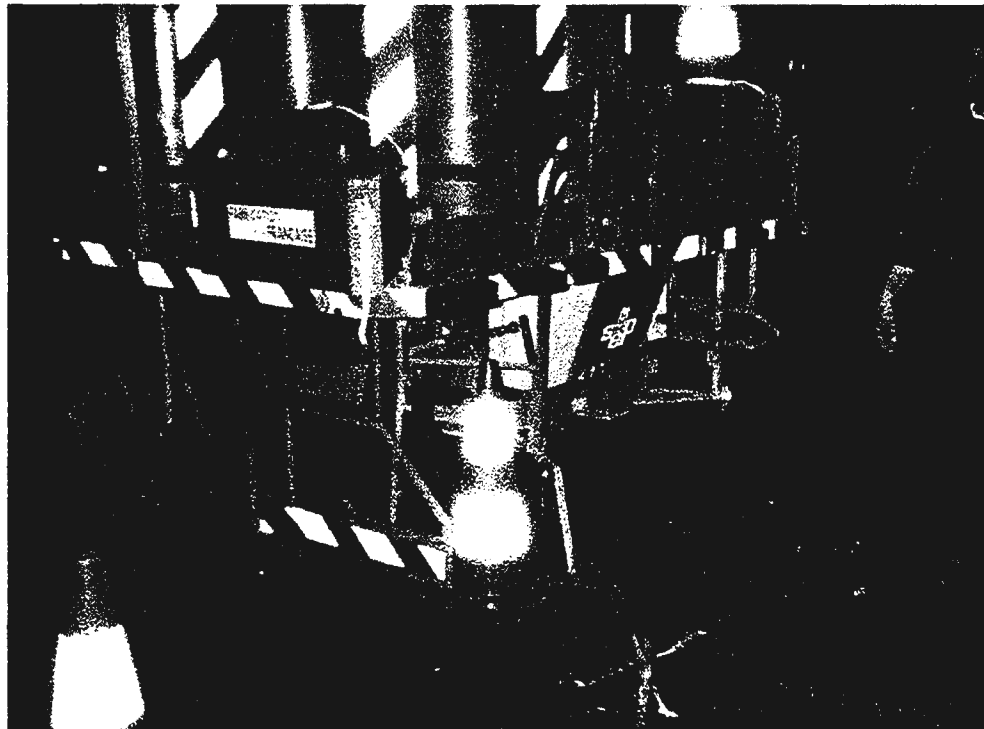

Figure 4.6/ Cone Deployment Mechanism

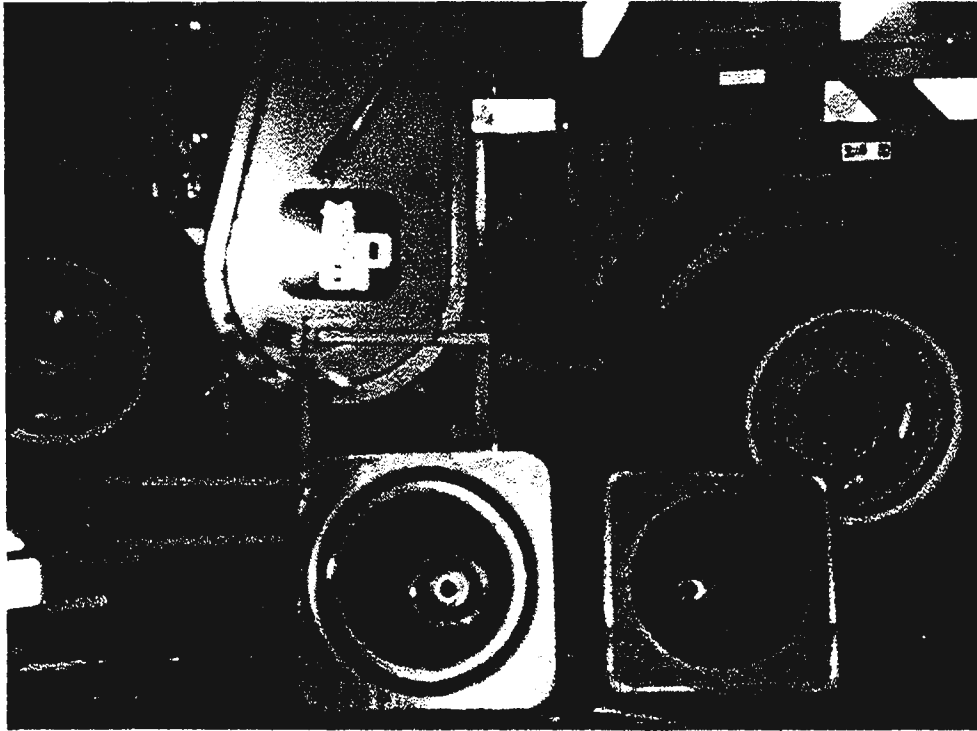

Figure 4.7/ Comparison of French Cone (left) and CALTRANS Cone (right)

5/ VIENNA

5.1/ Introduction

The city of Vienna has quite an extensive transit system which includes buses (Figure 5.1.1), streetcars (Figures 5.1.2 and 5.1.3), and subways. The system appears to be very efficient and well utilized.

Vienna's system carries approximately two million passengers per day, the majority by subway and streetcar, and the rest by buses and trolleys.

The 525 buses use mainly liquid propane and about half of the fleet have been using catalytic converters for more than five years. The trolley uses AC current. They did not have an AVL system at the time of the visit but were working on it. At that time, Vienna expected delivery of a new low-floor street-car prototype.

The subway system is about 20 years old, but the design is quite modern (see for example, the steerable bogies, Figure 5.1.4). The trains can be driven either manually or automatically.

Recently Vienna's transit authority completed a new subway maintenance facility at Alberg (Figure 5.1.5).

The facility itself is very large (Figure 5.1.6 shows a bicycle used by maintenance personnel within the facility) and is specifically designed to accommodate Vienna's subway cars which, by design, carry all components just underneath the floor. Consequently, in addition to vehicle lifts (Figure 5.1.7) there are a number of underground bays (Figure 5.1.8).



Figure 5.1.1/ Vienna Low-Floor Bus



Figure 5.1.2/ Vienna Streetcar



Figure 5.1.3/ Vienna Streetcar

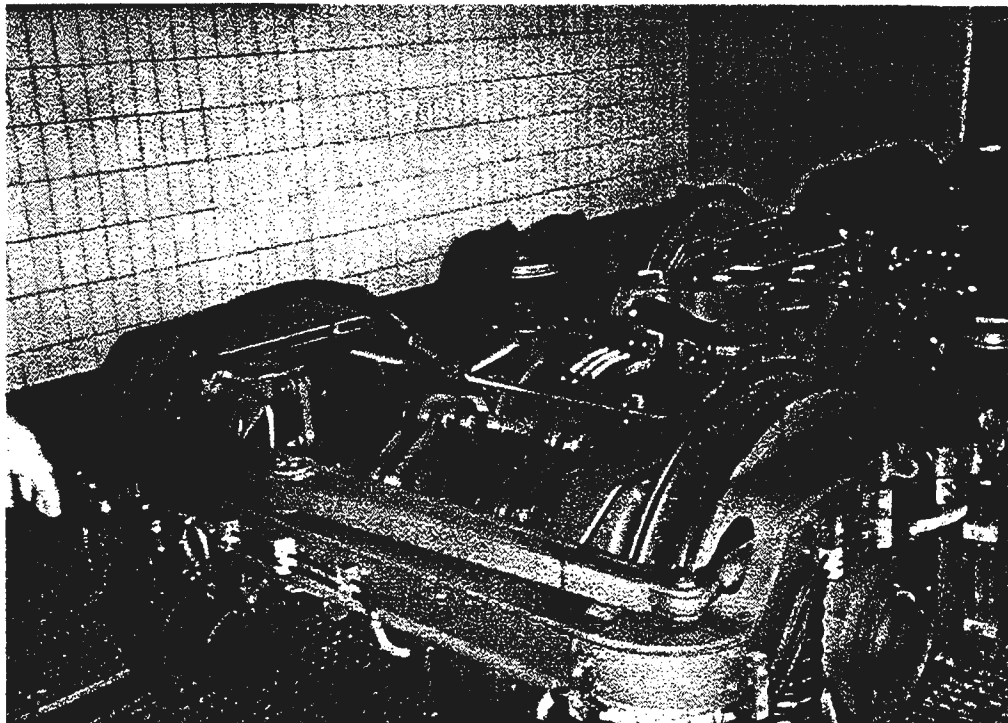

Figure 5.1.4/ Steerable Bogie with Disc Brakes

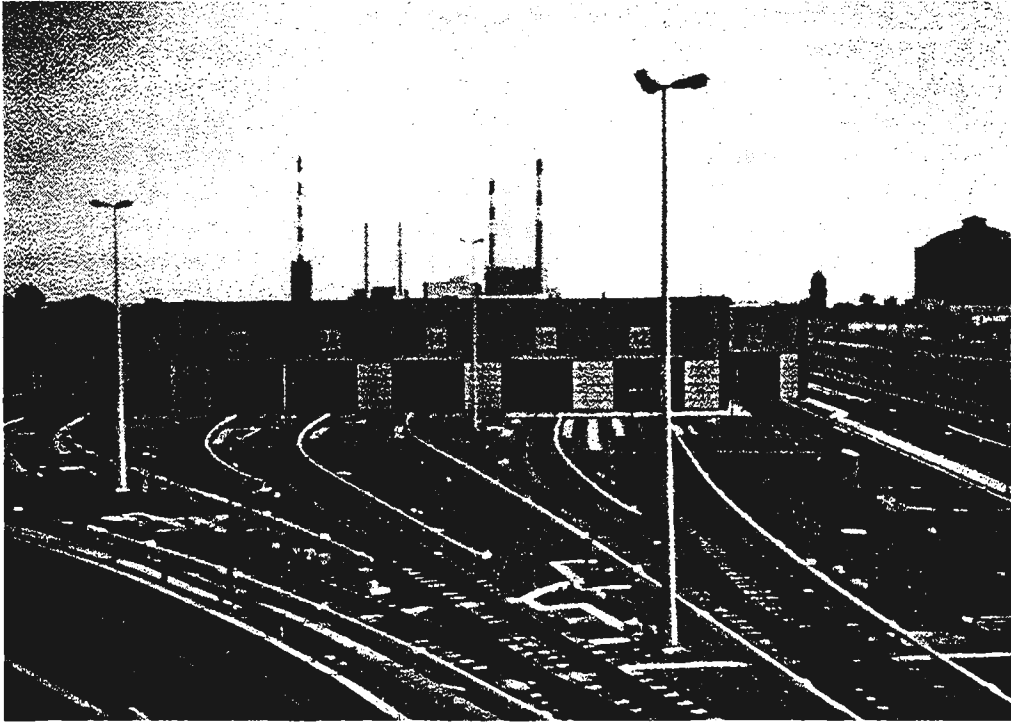

Figure 5.1.5/ Maintenance Building

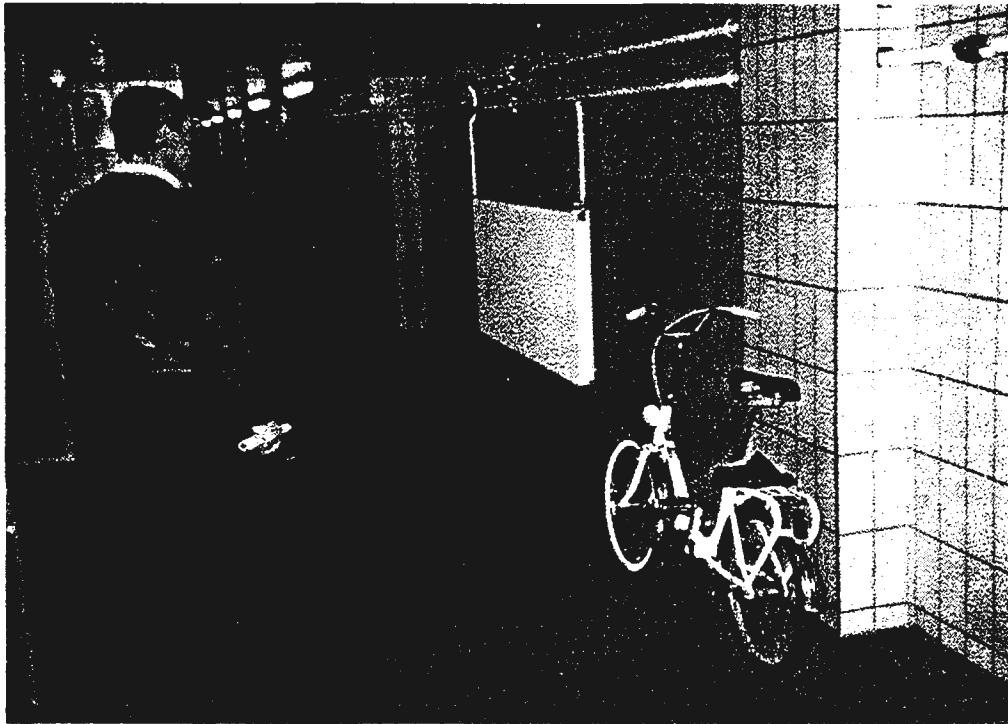
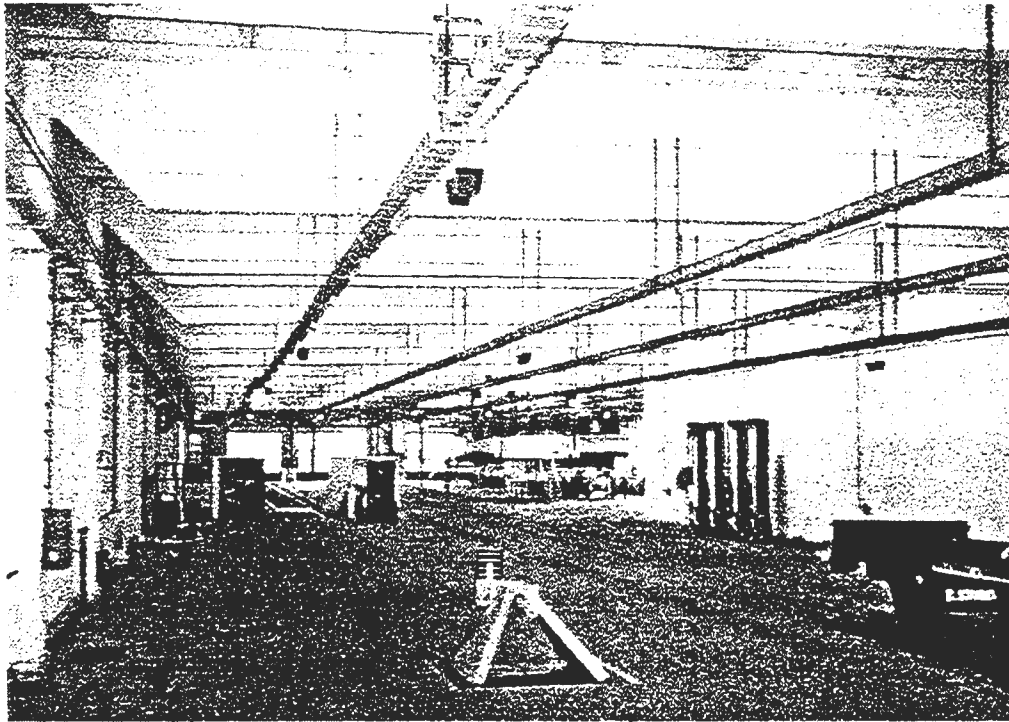
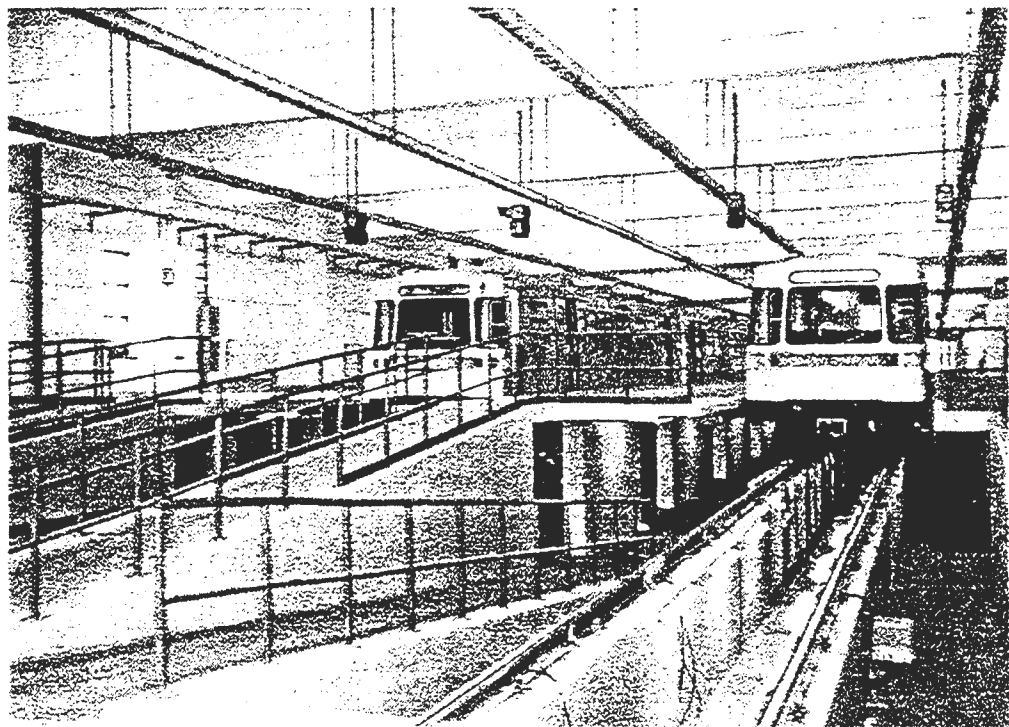

Figure 5.1.6/ "Means of Transportation" at Vienna Maintenance Facility



**Figure 5.1.7/ Interior of Vienna Subway Maintenance Building
– notice vehicle service lift in the background**



**Figure 5.1.8/ Vienna Subway Maintenance Facility Includes
Under-the-floor Access**

5.2/ Undercar Robotic Cleaning System

Before 1991, Vienna subways had 175 cars servicing lines U1, U2, and U4 and 47 cars servicing line U6. Line U3 opened in April 1991 adding 50 cars.

An average Vienna subway car covers 90 000 km/year and the undercarriage cleaning is scheduled at every 7500 service kilometres (i.e., monthly). The 36 m car, shown in Figure 5.2.1 is pushed into the cleaning building by a battery-driven locomotive.

The cleaning facility consists of a cleaning bay (Figure 5.2.2), the control room, and an extension housing compressors and dust collection systems.

The cleaning bay contains an elevated track and the train is simply pushed to the end stop (Figure 5.2.3) thus solving the positioning problem.

The side covers are manually removed, the door closed, and the train is ready for cleaning. The cleaning is done with compressed air only, which is delivered by four identical wall mounted robots (Figure 5.2.4) and by special nozzle assemblies located under each of the four bogies (Figure 5.2.5).

Each robot travels on its own track along approximately half a car length and is equipped with a multiple-nozzle tool (Figure 5.2.6) and local vacuum exhaust (via plastic pipe) shown in Figure 5.2.7. Also, the whole building has a down-draft recirculating exhaust system introducing air at ceiling level and collecting at floor level.

The robots' operation is staggered in time to reduce the required capacity of the exhaust and compressor systems but still the cleaning of a car takes in the range of 20 minutes.

The robotic system is programmed off line and requires very little knowledge to operate. The progress can be followed on a simple control panel. The exhaust system appears to be quite efficient (see robot working in Figure 5.2.8) and the dirt is eventually collected in a standard garbage can (Figure 5.2.9).

Entry to the cleaning area is protected by a series of infrared sensors as shown in Figure 5.2.10.

The cleaning operation appears to be quite effective and well accepted within the property.

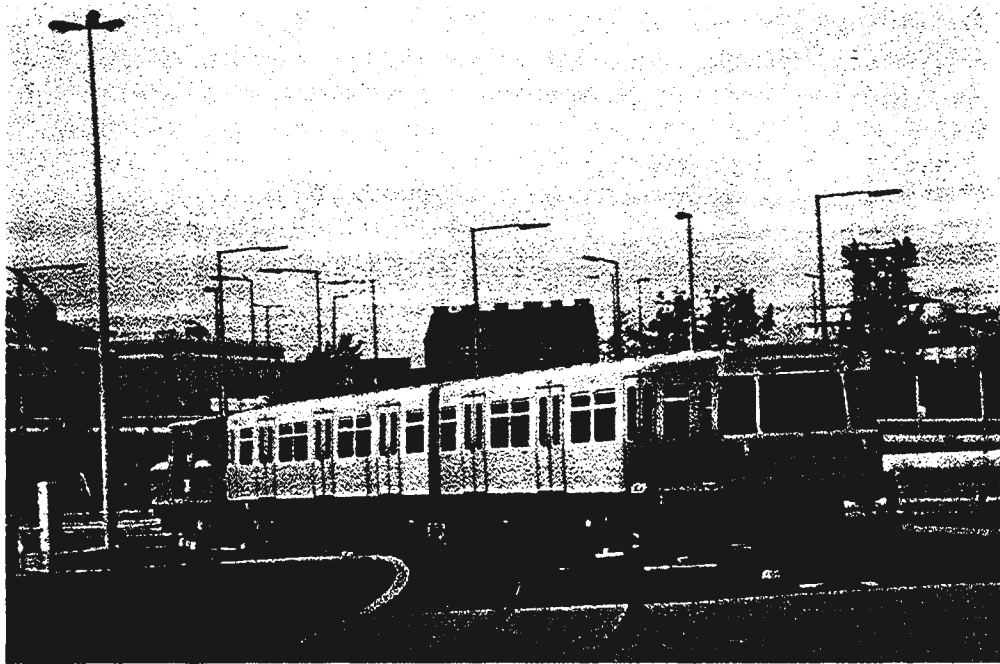

Figure 5.2.1/ Vienna Subway Car Arriving at the Cleaning Building



Figure 5.2.2/ Interior of Robotic Cleaning Bay

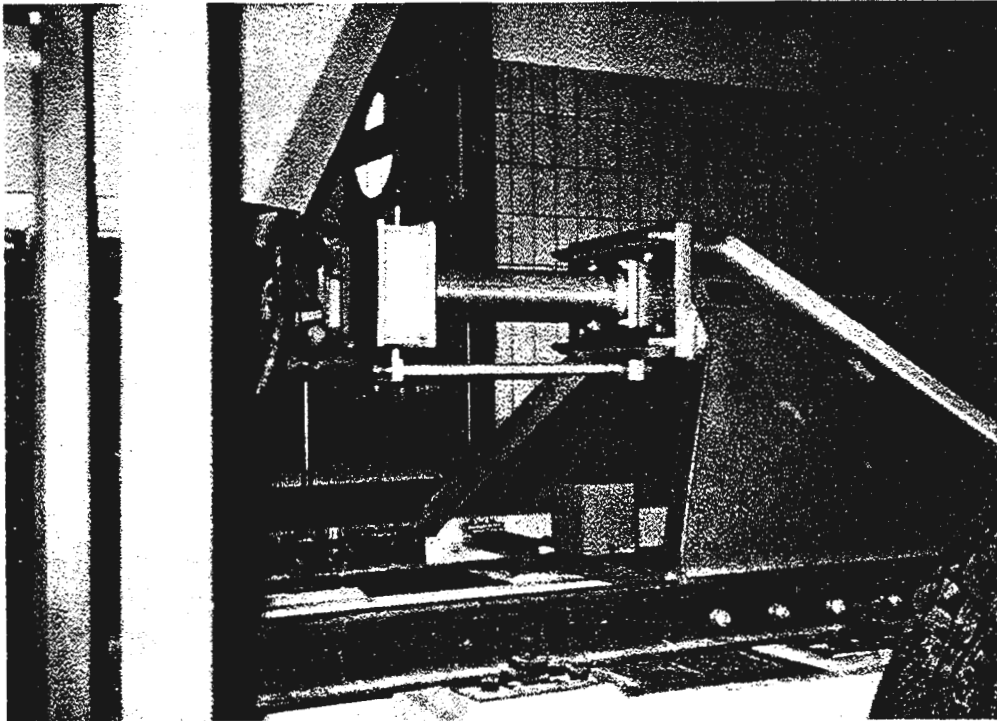

Figure 5.2.3/ Car Positioning Mechanism

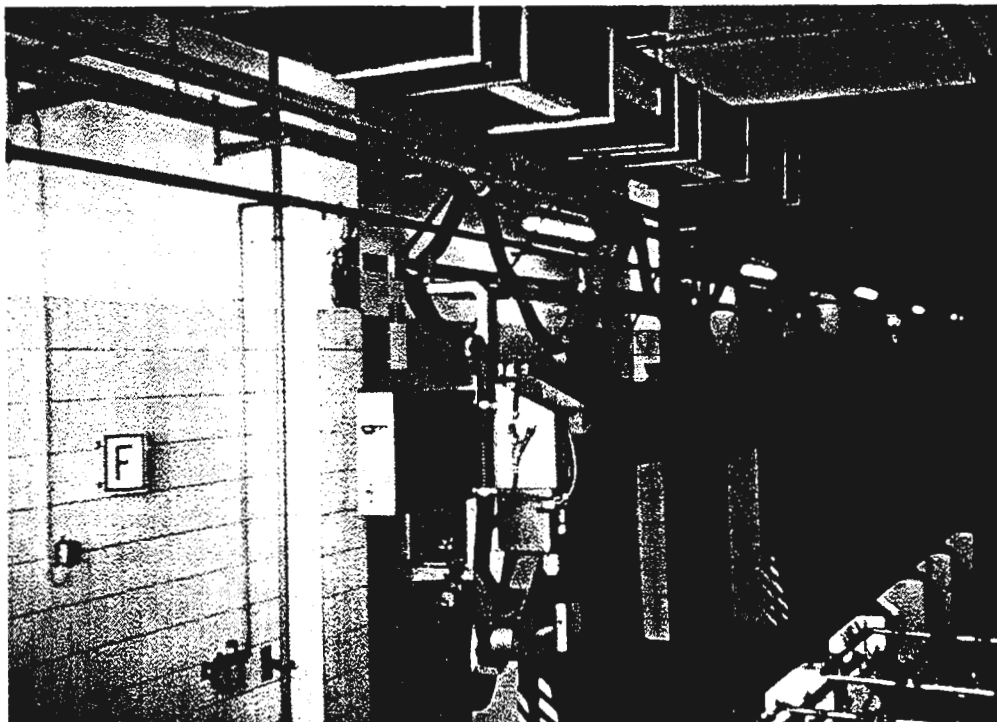

Figure 5.2.4/ One of Four Cleaning Robots

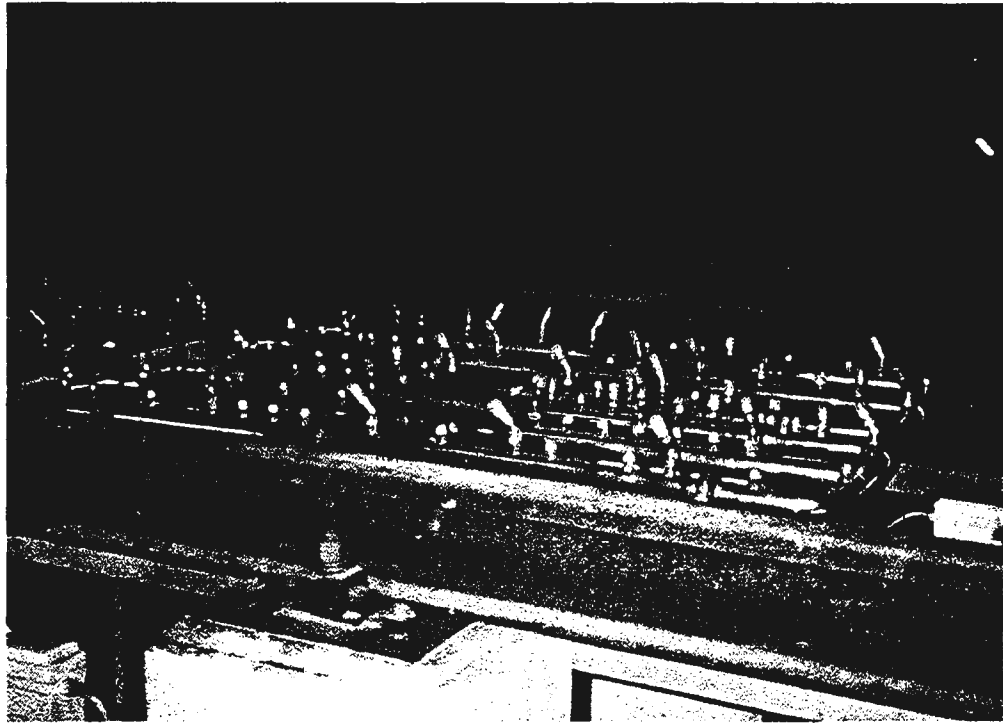

Figure 5.2.5/ One of Four Bogie Cleaning Nozzle Assemblies

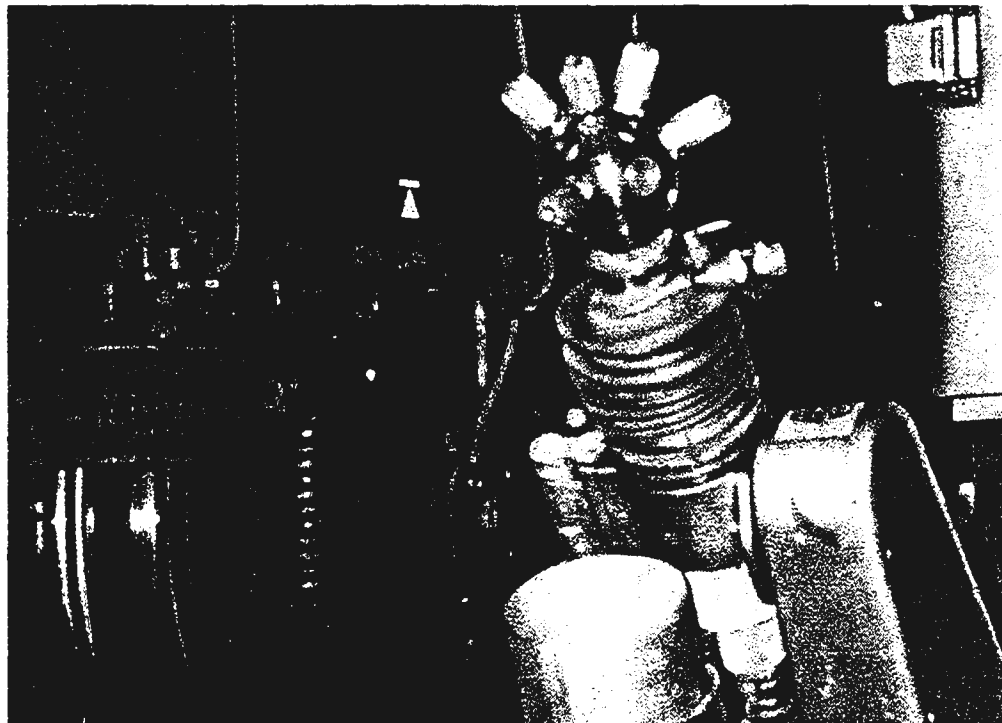
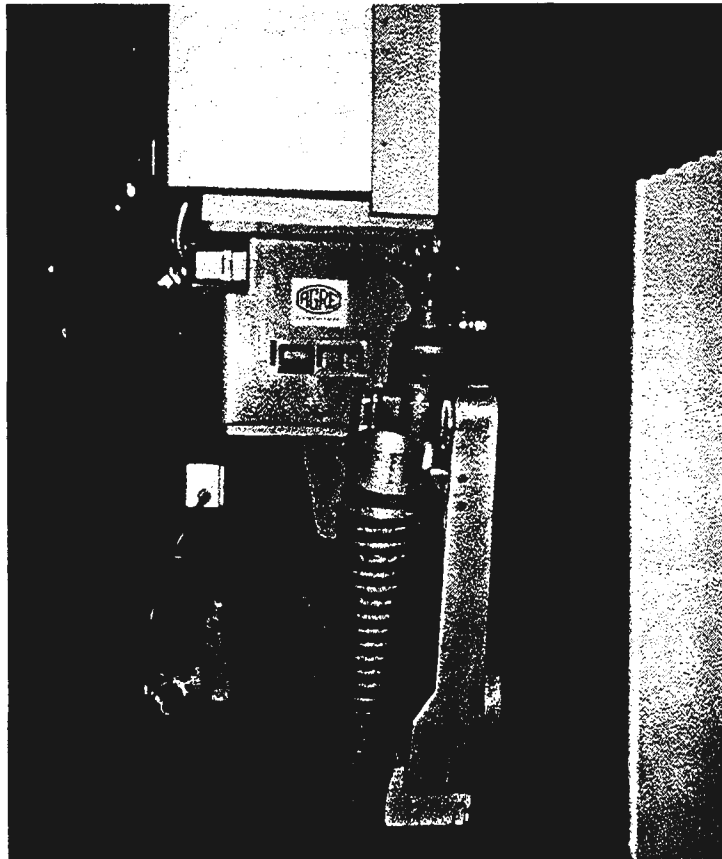

Figure 5.2.6/ Multiple-nozzle Tool



**Figure 5.2.7/ One of the Cleaning Robots
– note local dirt collection tube**

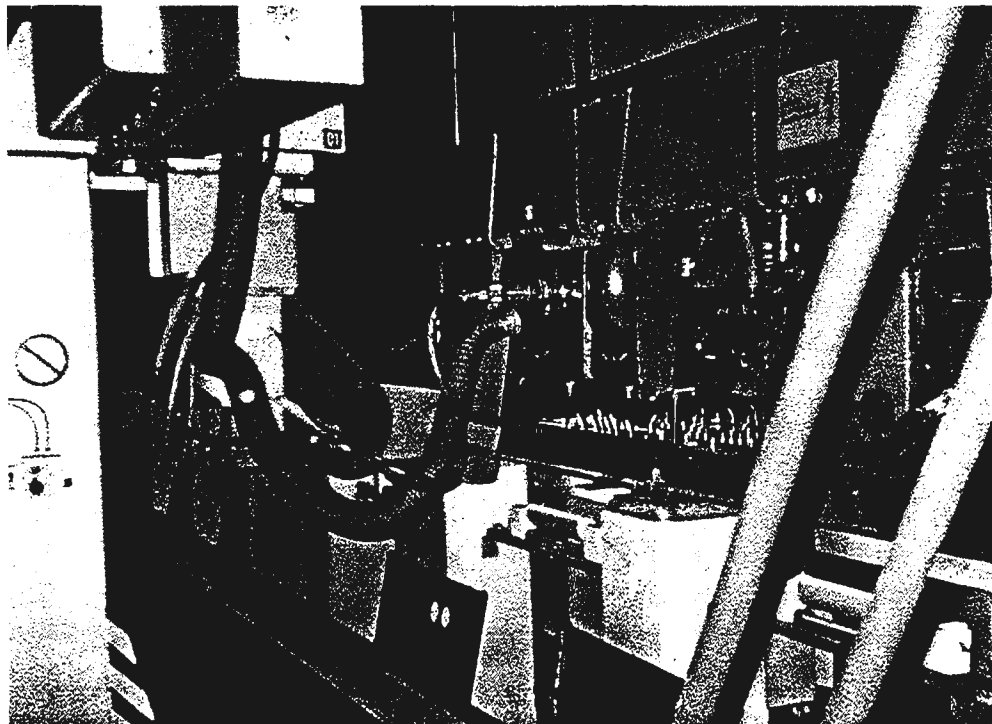

Figure 5.2.8/ Robot Cleaning Compressor Assembly

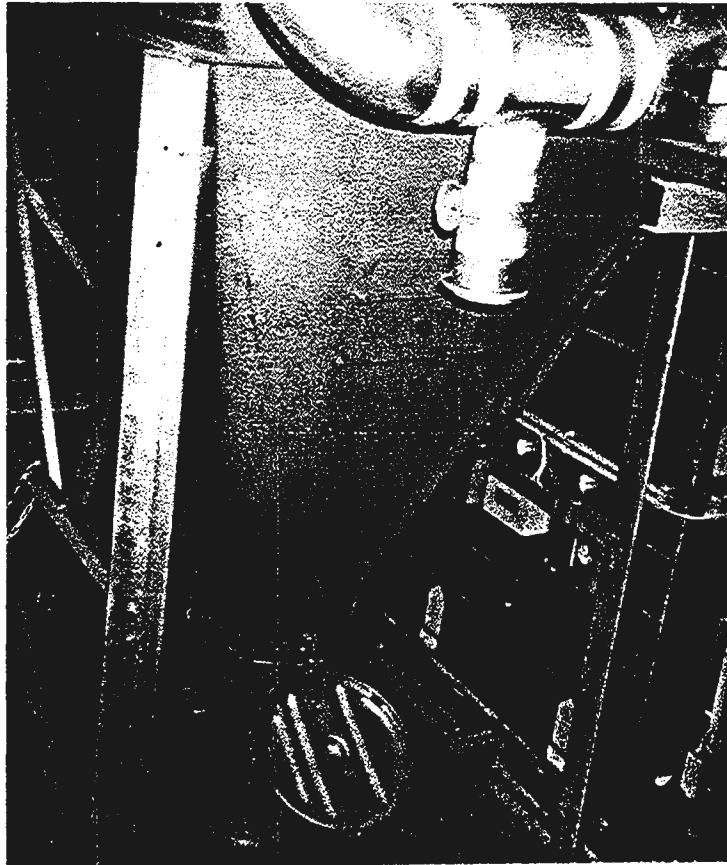

Figure 5.2.9/ Waste Collection System Using Standard Garbage Can

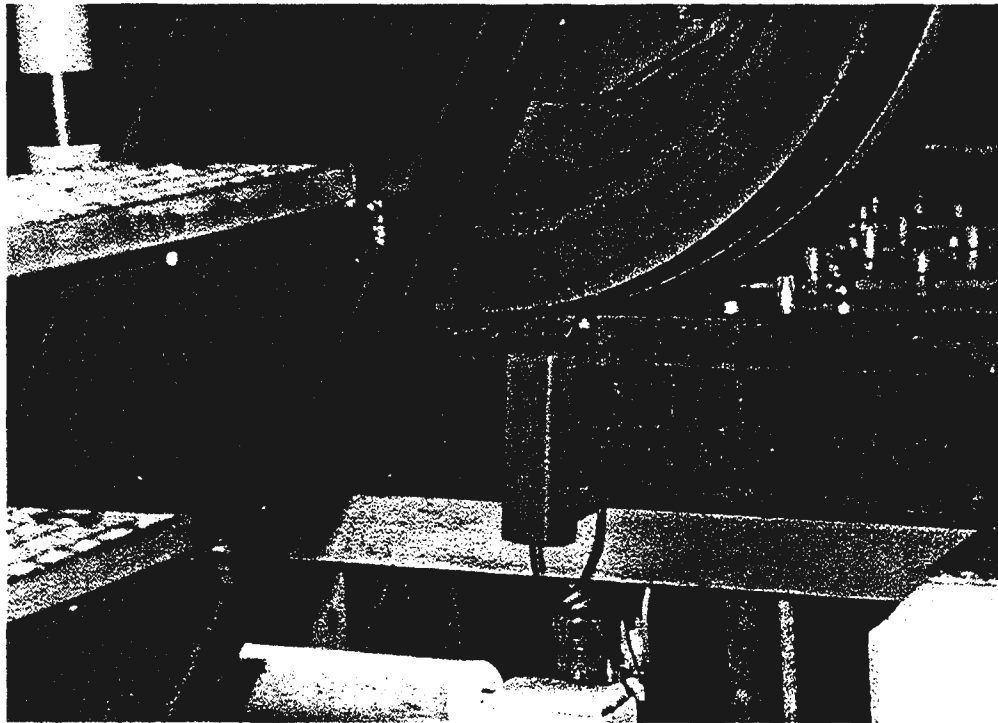

Figure 5.2.10/ Infrared Sensor Mounted on Rail

6/ WEBASTO and ZEUNA STÄRKER FACILITIES

Webasto AG is a well known automotive heater manufacturer and Zeuna Stärker manufactures exhaust systems. They are located close to each other with Webasto on the outskirts of Munich and Zeuna Stärker in Augsburg, a short drive away.

Webasto manufactures heaters and has a research facility and a factory in the Munich suburb of Stockdorf. Recently, it also purchased and successfully reorganized a factory in former East Germany.

The Munich facility is in the middle of a pleasant residential area, but the company is unable to move, as most of the staff would not be willing to add more than a few minutes to their travelling time. With a local unemployment rate of 0.3% during the recession, moving could pose some difficulty.

The Munich facility houses extensive research and development labs where testing takes place. In fact, Webasto, like many mid-sized German companies, spends approximately 10% of its gross income on R&D in order to prosper.

The Munich facility also manufactures over 100 000 heaters a year. This is done by having most parts manufactured outside and using semi-automated assembly, where a judicious mixture of special automated equipment and people provides very high productivity.

Zeuna Stärker is a well known exhaust system manufacturer. It is OEM supplier to such companies as Rolls Royce, Volvo, BMW, Daimler Benz, and Alfa Romeo. It employs 1200 people in three factories in Augsburg plus one factory in South Africa. Its R&D department employs 130 people, more than 10% of the work force. It also has extensive apprentice programs (8% of the work force). Its 1990 sales were DM 280 million, a very respectable output per worker, which was achieved using specialized machinery and robotics. The company appeared to be very busy with considerable construction activity.

During the last few years, Webasto and Zeuna Stärker did extensive research on particulate traps for heavy vehicles. Webasto appeared to concentrate on a double filter type, while Zeuna Stärker developed a single filter, continuous cleaning type model.

The units from both companies appeared to be superbly engineered and of very high quality. My attention was particularly attracted to Zeuna Stärker's almost uniform temperature distribution across the ceramic filter with a temperature difference of less than 10°C.

The Zeuna Stärker trap operation is shown in Figure 6.1 and the unit installed in a transit bus is shown in Figure 6.2.

Due to another postponement of "clean air" legislation, Webasto decided to sell its technology to Zeuna Stärker and, at the time of our visit, the company, Zeuna Stärker, was in the process of deciding if it wished to manufacture for the North American market.

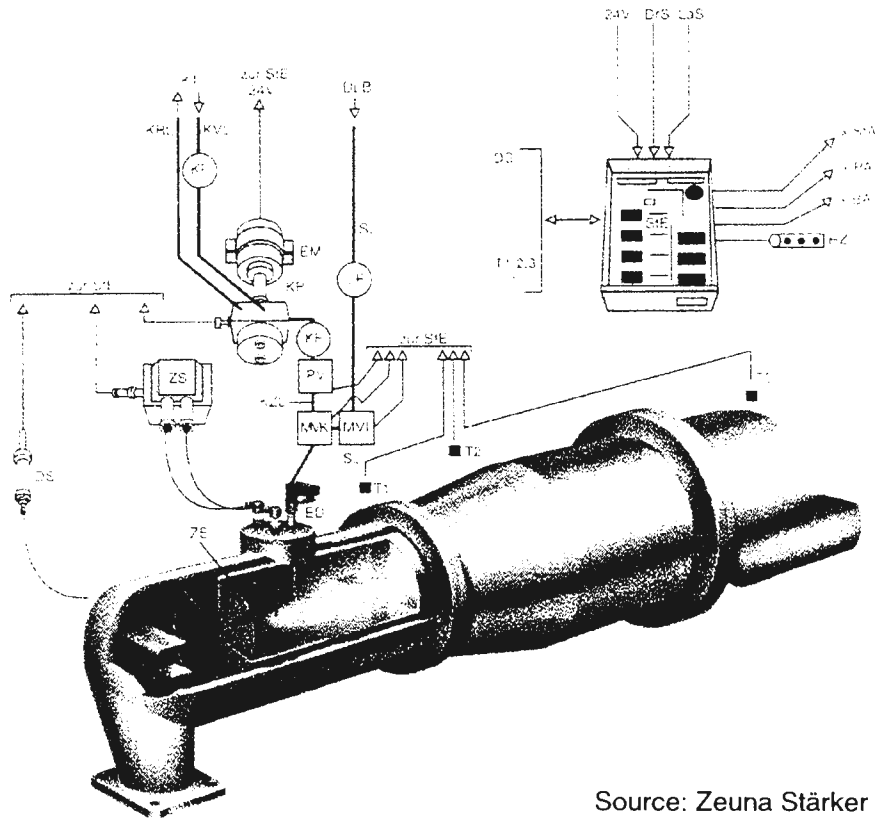

Figure 6.1/ Zeuna Stärker Trap

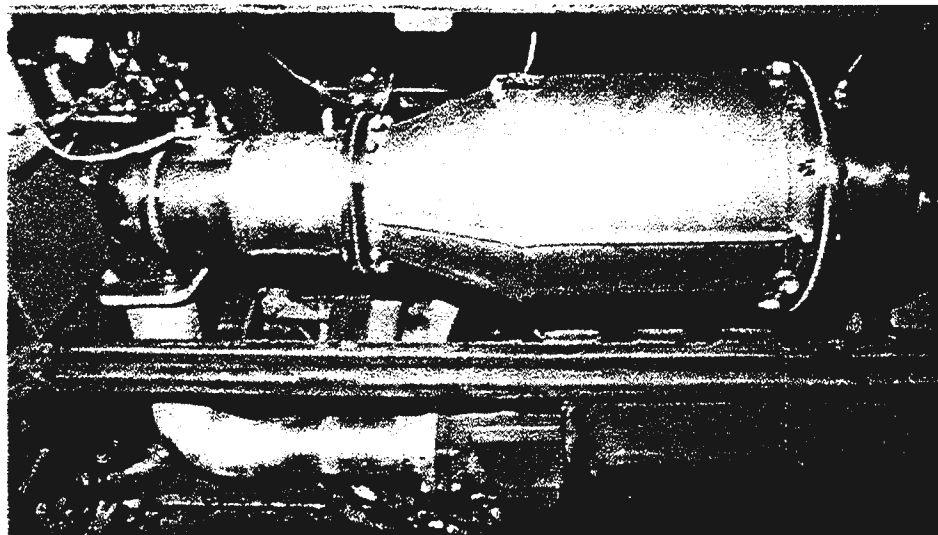

Figure 6.2/ Trap Installed in a Bus

7/ STUTTGART/NEOPLAN

Stuttgart, located at the edge of the Black Forest, is one of the most important industrial centres in Germany. Many world-famous companies such as Bosch, Daimler Benz, and Porsche are located there. The city is relatively large for its population with a large percentage of land taken by parks, gardens, and vineyards. An extensive transit improvement program was started in the mid-1970s. The backbone of the system is a streetcar network, in addition to buses and heavy rail.

In the centre of the city and a little farther, the streetcars travel underground, mainly on their own right-of-way. The system's efficiency and low fares has prompted many families to use transit exclusively or to own only one car. Thus, the traffic situation in Stuttgart is, by European standards, quite good, and a pedestrian-only area in the centre of town is very pleasant.

One of the most interesting European bus manufacturing companies, Neoplan, is headquartered in the city and was the object of our visit.

Neoplan started bus manufacturing in 1928 and today manufactures a whole range of buses in its plants in Germany, and also other countries. In the 1980s it continuously increased its production, in spite of the fact that the overall bus market was stagnant. For example, in 1990 1150 vehicles left three Neoplan German factories (Stuttgart, Pilsting, and Berlin), 15% more than in 1989. It now has 15.6% of the overall German bus market. Its market share is higher in some specialized areas; for example, it claims a 59.3% share in the luxury doubledecker coaches. Neoplan also produces low-floor buses and recently became the first, and at the time of the visit, the only producer of carbon fibre bodied buses.

The Stuttgart facility contains an administration tower, production areas, and a busy vehicle delivery hall. As the area around the plant is zoned agricultural, only upward expansion is possible. The manufacturing is on more than one level and the construction of higher levels was in progress at the time of the visit. Figures 7.1 and 7.2 show interior scenes where the traditional (i.e., steel frame) buses are made, while Figure 7.3 shows typical front suspension.

A few years back, Neoplan designed a new, composite bodied bus, the Metroliner. The body is constructed from a resin/fibreglass combination with approximately 25% of the matrix being carbon fibre. Two, low-floor level vehicle models were manufactured at the time of the visit: 8008 (8 m length) and 8012 (length 12 m). The weight of these vehicles is roughly one-third lower than comparable steel-framed vehicles.

At the time of the visit, there were 25 (diesel powered) prototypes in various German transit properties.

Figure 7.4 shows the overall specifications of model 8008 and the actual bus is shown in Figure 7.5. The suspension details are shown in Figure 7.6. The Metroliner is produced in segments shown in Figure 7.7.

Recently, the production process has been changed to work on a double wall principle, thus, saving an additional 500 kg of weight. Other improvements were made; for example, the rear axle redesign resulted in a significant floor slope reduction toward the back.

Compared to steel-framed vehicles, Neoplan estimates a saving of 150 000 litres of fuel over the vehicle's service life, and a doubling of service life (to 25 or 30 years) due to the non-corrosion of composites. They also estimate a 30% saving in energy required for manufacturing and recycling of materials at the end of the vehicle's life.

The Metroliners are produced in Mengen on a four-day cycle. We were shown an interesting development of Metroliner: an electric drive vehicle where the rear wheels are driven by a single small electric motor and a battery pack. Although the range is short, the battery pack can be changed in four minutes by one person.

Another development, only verbally described but since demonstrated in Geneva in the spring of 1992, was "electric motor on each wheel" propulsion with a variety of hybrid propulsion considerations.

All told, the Metroliner concept appears to be probably the most significant development made in bus construction to date.



Figure 7.1/ Neoplan Factory Second Floor. Frames are made on the second floor and then lowered through opening in floor (shown on left).

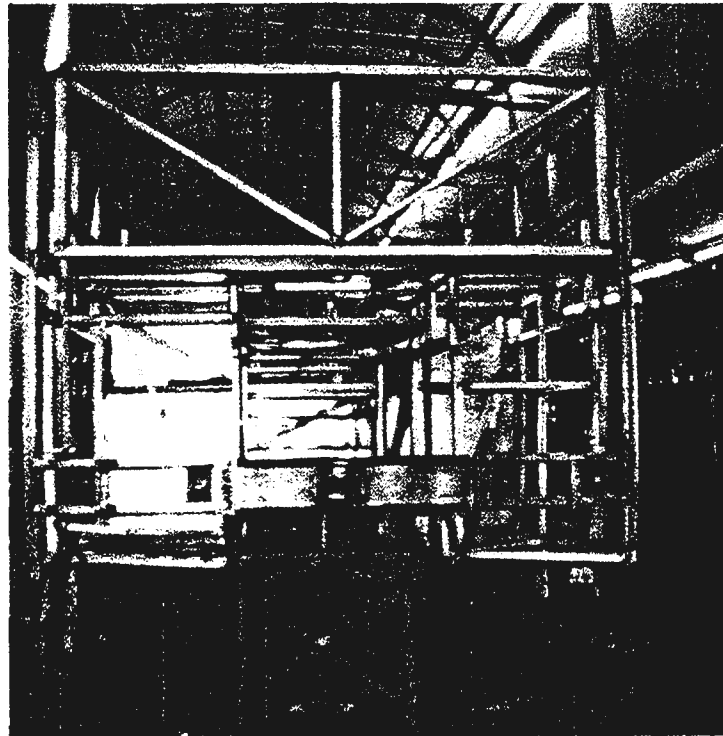

Figure 7.2/ Neoplan Double-decker Frame

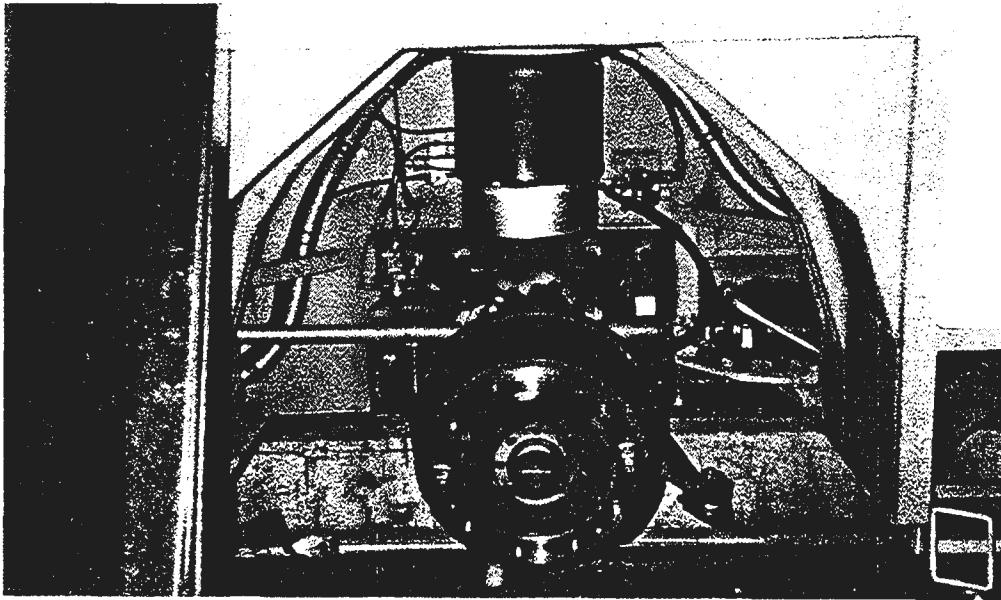

Figure 7.3/ Front Suspension of Neoplan Bus

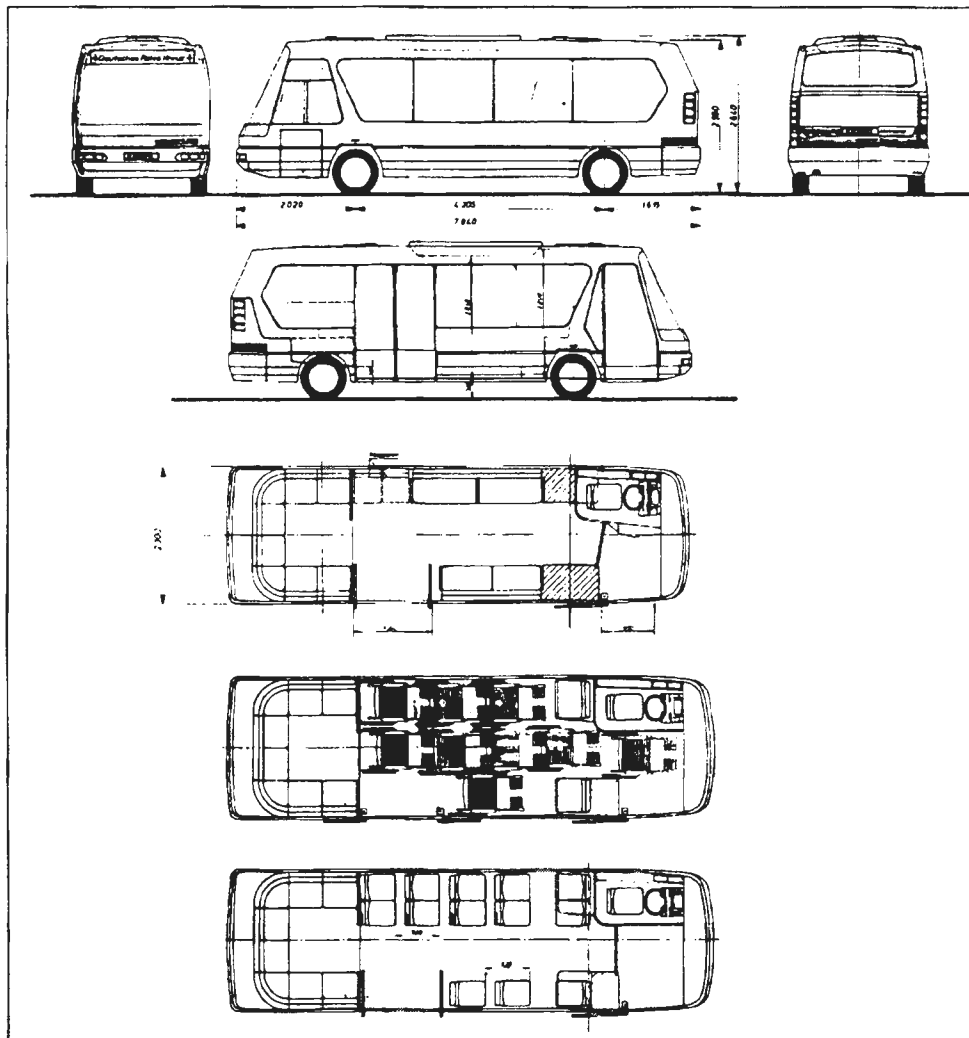

Figure 7.4/ Neoplan Metroliner 8008 Model Specs Source: Neoplan

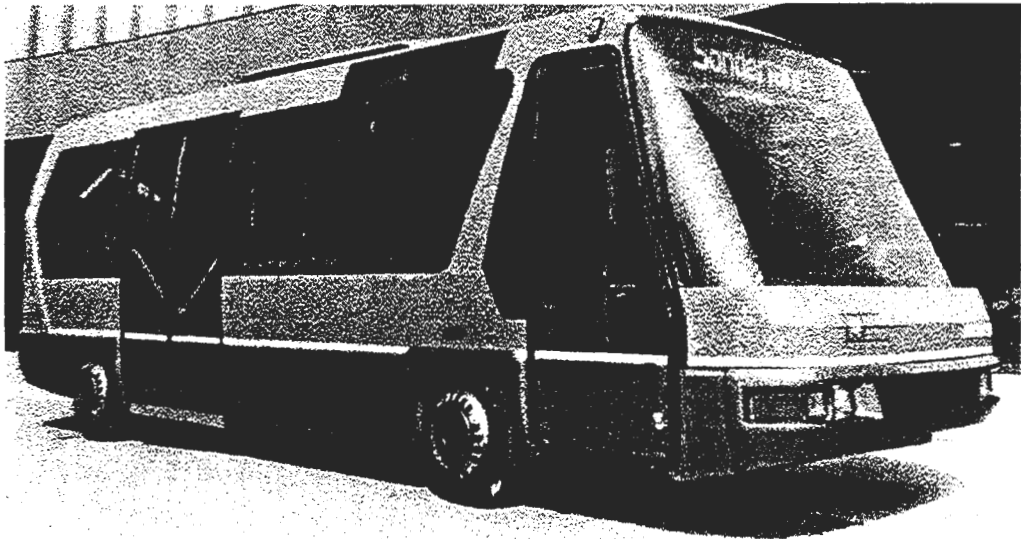
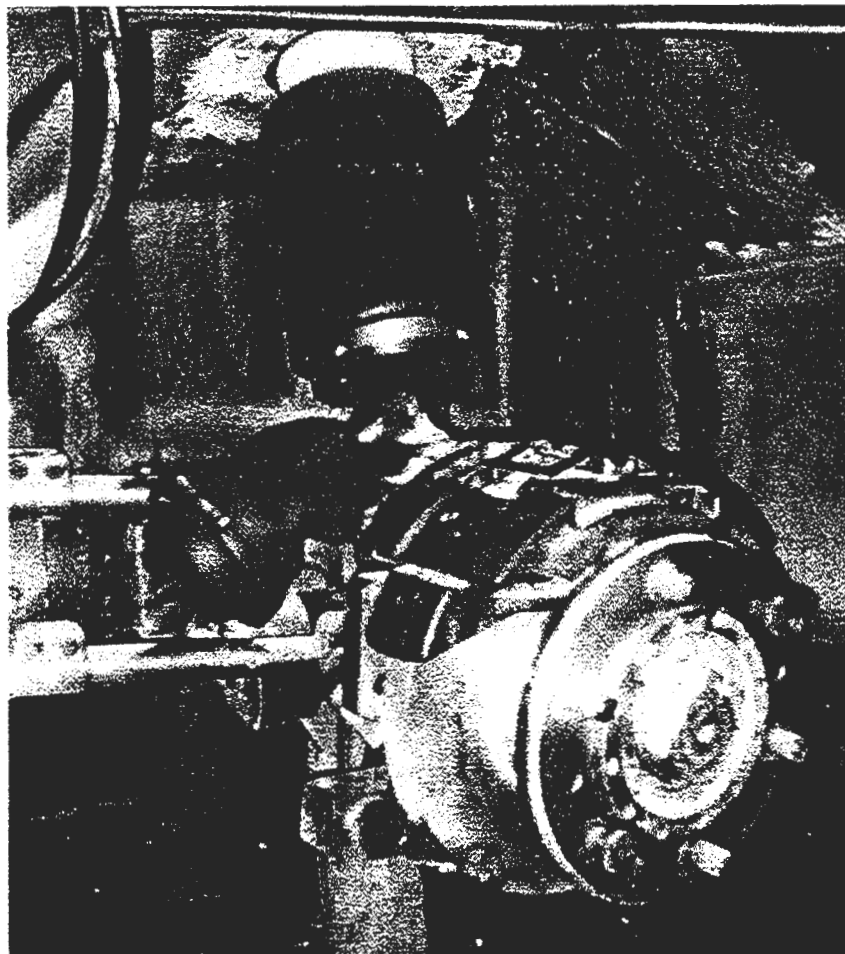

Figure 7.5/ Neoplan Metroliner Model 8008

Source: Neoplan



Source: Neoplan

Figure 7.6/ Neoplan Metroliner Suspension Detail

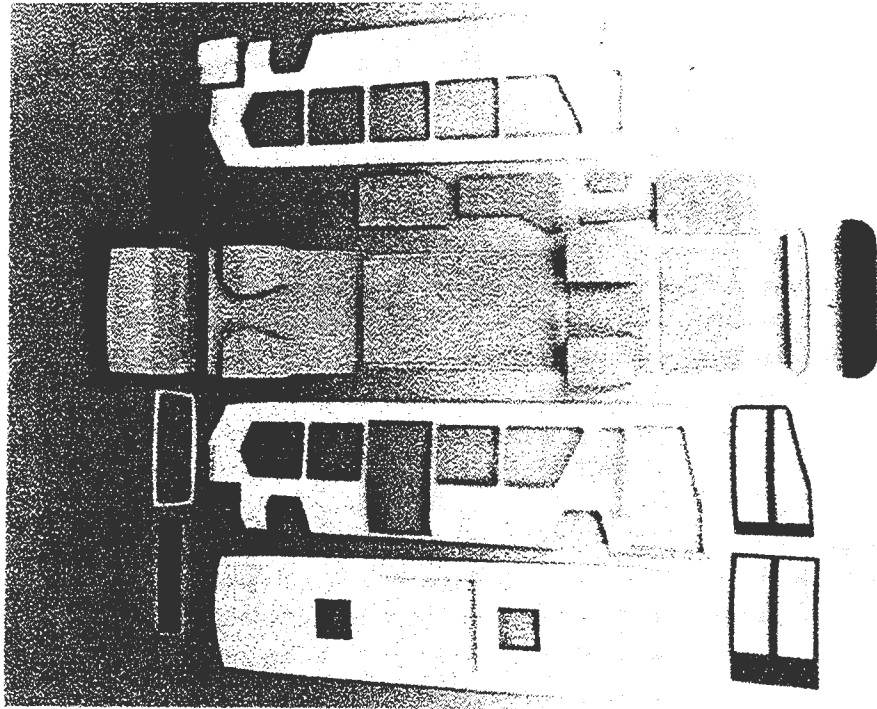

Source: Neoplan

Figure 7.7/ Set of Parts Required to Produce Metroliner Body

8/ COLOGNE

Cologne is home to Verband Deutscher Verkehrsunternehmen (VDV), roughly translated as the German Association of Public Transport Operators. VDV has a membership of over 500 transit companies. They are mainly German, but there are also members from Switzerland, Austria, Finland, and Holland.

VDV is a powerful organization. It liaises with the federal government of Germany, coordinates all research activities, prepares standards, and even does purchasing (e.g., fuel) for all its members. VDV's headquarters are in Cologne and it has a staff of 65 people (mainly technical).

VDV is active in all transit areas, both operational and technical. It also, together with the German government, directs various research activities and has input to the government's fiscal decisions. VDV also publishes policy standards and directs various development activities, e.g., low-floor vehicle development.

More and more pressure in Germany to remove at least some cars from the cities and to clean up the environment has prompted the German federal government to allocate an additional DM 10.5 billion (\$7.7 million Cdn.) over five years for new transit systems.

Incidentally, German cities receive 27 pfennigs (24 cents Cdn.) of the tax collected for each litre of gasoline sold, which is supposed to be spent half on transit and half on roads.

New environmental laws were expected to take effect six months from our visit and VDV has taken preventive action by ordering low-sulphur fuel. Initially, the new fuel will be accessible to roughly 60% of VDV members within one year at the additional cost of 2-3 pfennigs (1.8 to 2.7 cents Cdn.) per litre. They expected to have it widely available to all properties shortly thereafter at much less of a price difference. The initial order has a sulphur content of 0.05 grams/kW hour, but again, they expect to reduce it to 0.02 gram/kW hour. VDV strongly feels that low-sulphur fuel (plus catalytic converter) is the way to go, versus particulate traps.

VDV is heavily involved in technical standard development and input to new European standards is its priority. As the other countries are much less advanced, the united Europe may find itself with de facto German standards with perhaps some minor additions from the French.

To give an example, VDV developed the IBIS standard (see Figures 8.1 and 8.2) which describes an on-board electronic system. The standard defines only the important functions: vehicle-to-central and on-board communication protocol, vehicle-to-vehicle communication, main panel size and layout, and various devices, current and present, which can be attached to a communication bus.

The definition not only provides for standard AVLIC requirements but also includes fare collection devices, equipment to communicate with the passengers (e.g., on-board displays), and health monitoring.

The specification defines interfaces only, which permits many manufacturers to produce similar items. Such an item can then be plugged into a network, and must work with the rest of the system, by definition.

This approach permits German transit companies easy-to-use and inexpensive equipment and not only permits market competition but de facto creates a larger market by dispensing with expensive and time consuming North American style developments.

The IBIS spec developed in the early 1980s has been upgraded by standardizing the transit data base. This permitted the transit software to work almost anywhere, as long as it works through this data base. Again, this has resulted in an enormous savings in cost and time.

VDV has many other standards, for example, for infrastructure, tracks, components, electrical, etc. During the last few years, it has developed a new low-floor standard for vehicles and related facilities. The standards are relatively simple, as seen in Figures 8.3 and 8.4.

VDV is also heavily involved with low-floor streetcar development and is testing some models developed to their specifications (Figure 8.5).

VDV also publishes periodicals, in addition to many specialized reports. *Der Nahverkehr*, for example, contains plenty of interesting high-quality technical papers.

An interesting device to help passengers with luggage was spotted at the local rail station. It is shown in Figure 8.6.

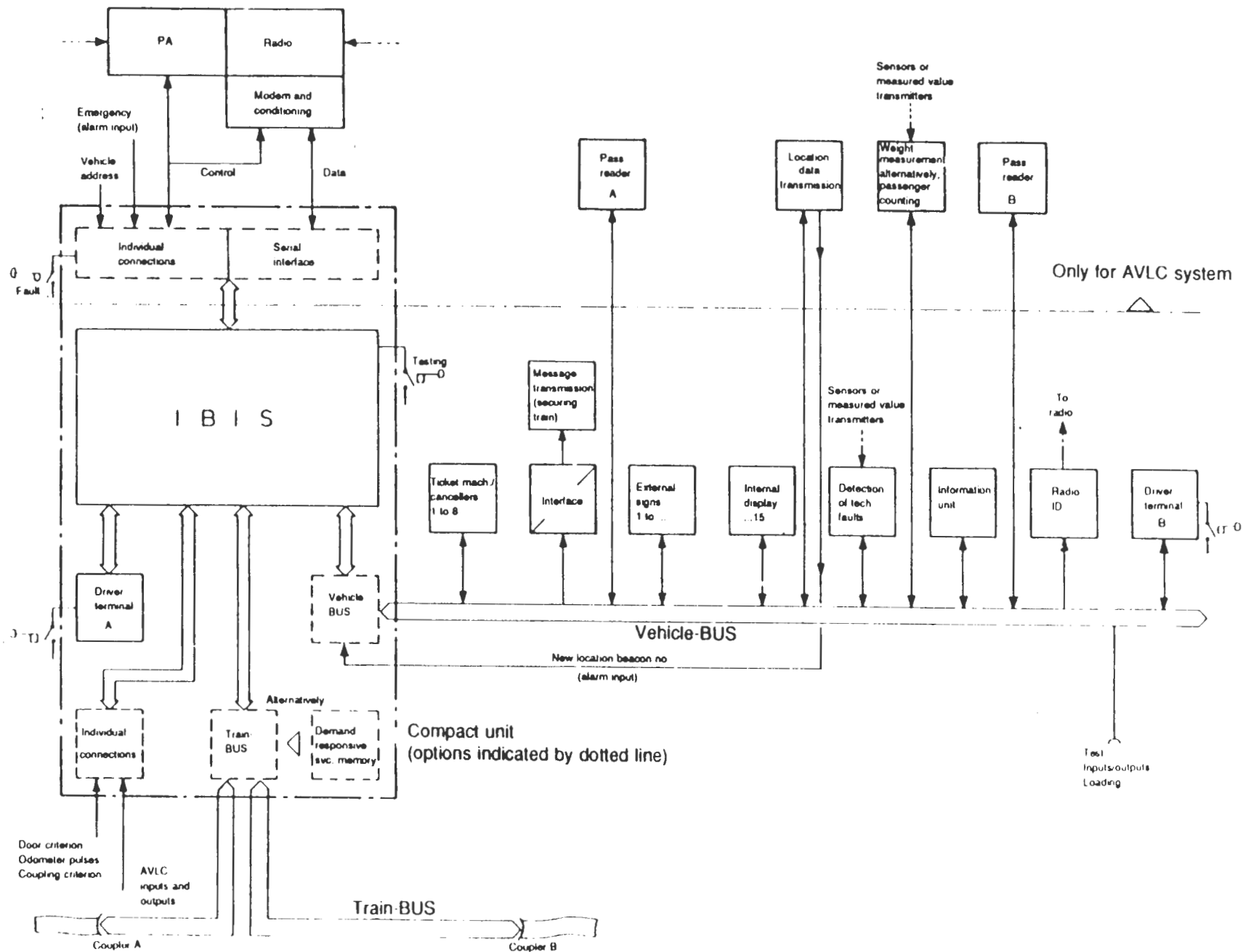

Source: Verband Deutscher Verkehrsunternehmen (VDV)

Figure 8.1/ IBIS System Overview (Integrated On-board Information System)

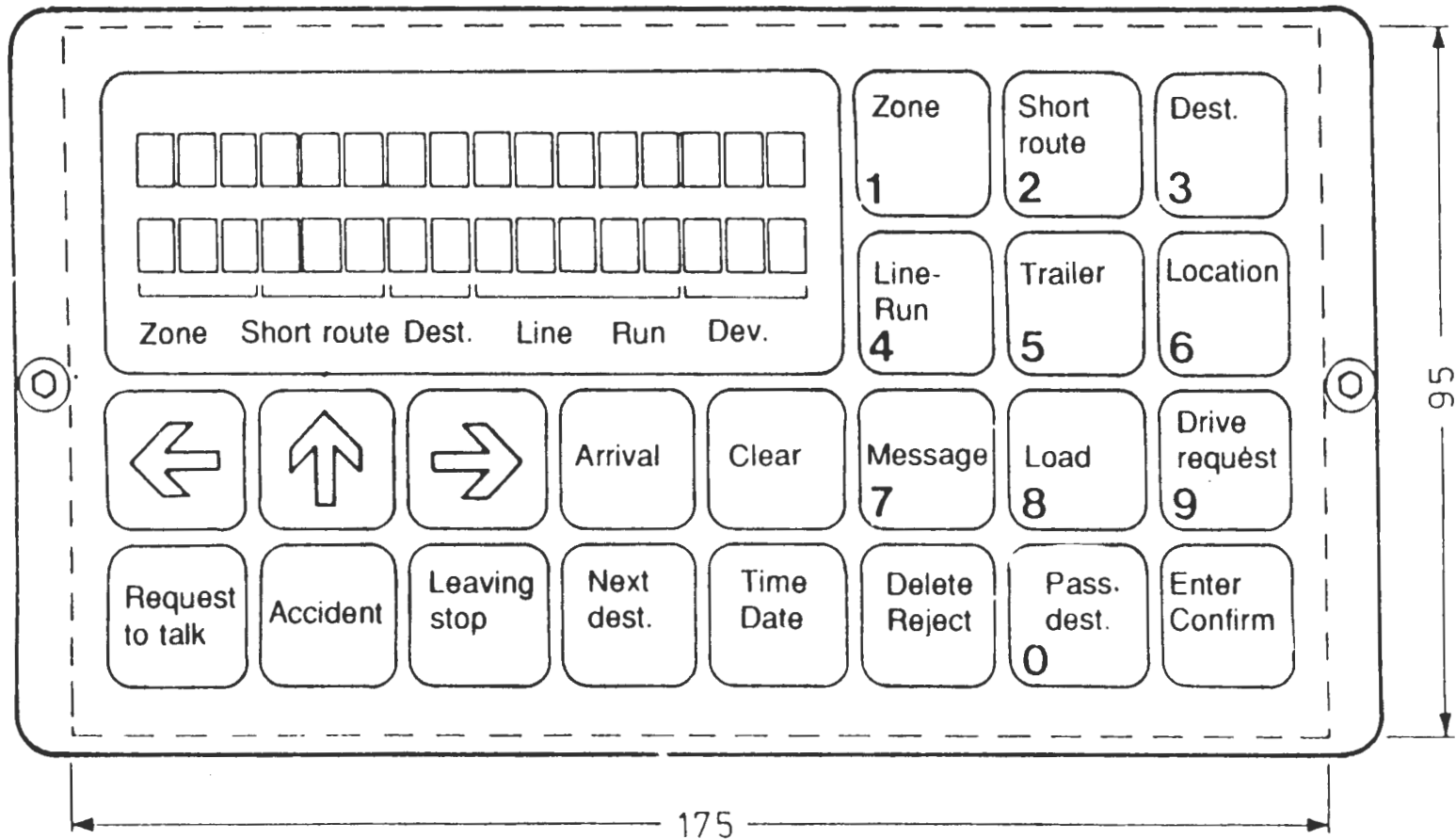

Depth 150±0.2 mm incl. plug connections

Keyboard division 19.05 mm = 3/4"

Other operating elements located elsewhere:

Emergency call

Transmission / public address button

Volume control for driver's public address system

Ticket identification unit

Source: Verband Deutscher Verkehrsunternehmen (VDV)

Figure 8.2/ Central Unit with Integrated Driver Terminal, Example 1 for Key Allocation

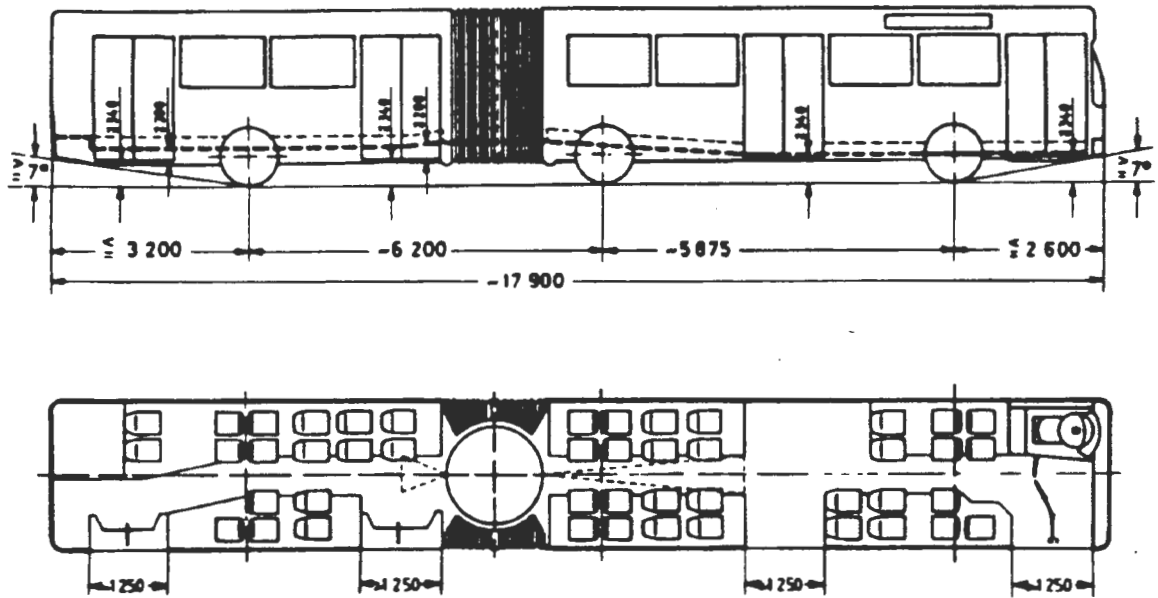

Source: Verband öffentlicher Verkehrsbetriebe (VöV)

Figure 8.3/ Low-Floor Articulated Bus

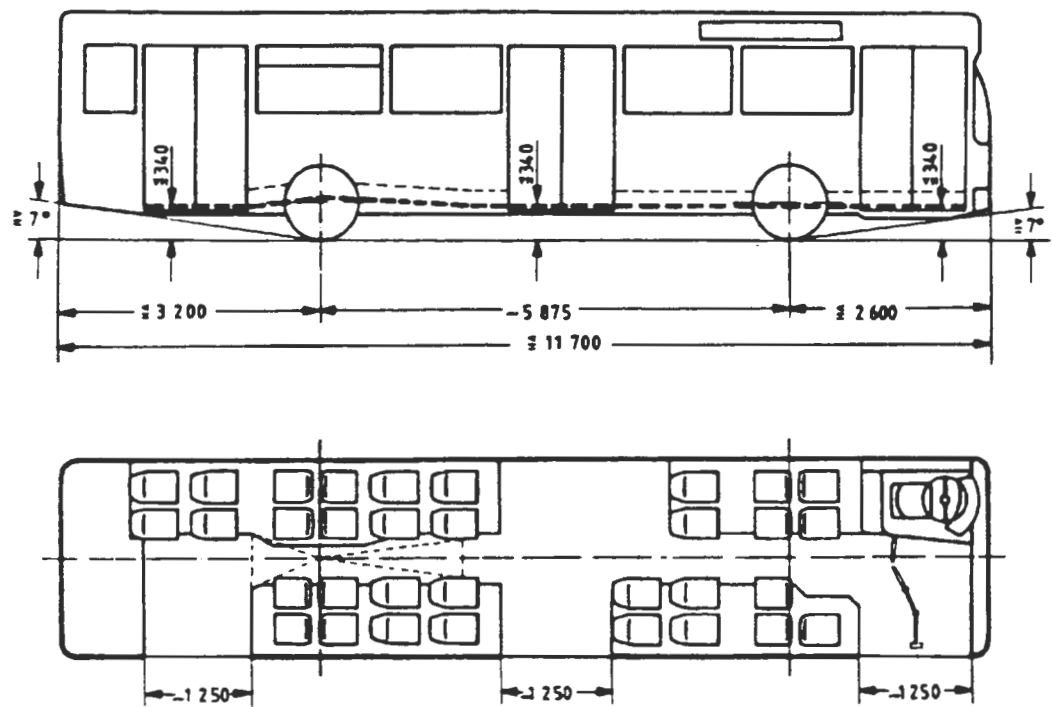

Source: Verband öffentlicher Verkehrsbetriebe (VöV)

Figure 8.4/ "Line-bus" Standard

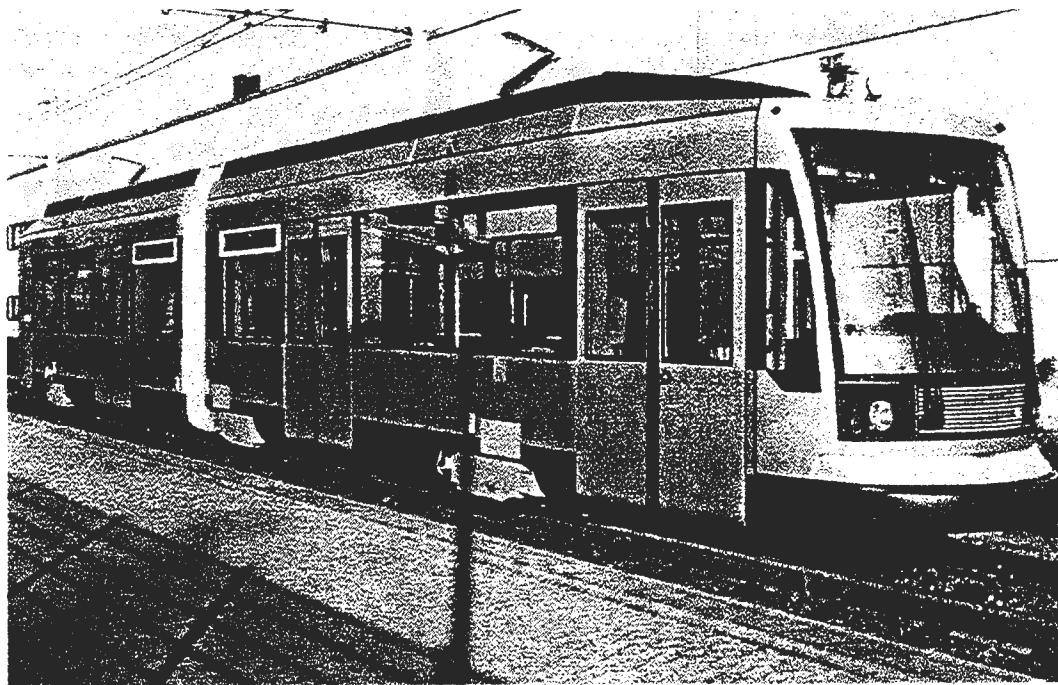

Source: Verband öffentlicher Verkehrsbetriebe (VöV)

Figure 8.5/ VDV Low-Floor Streetcar Prototype

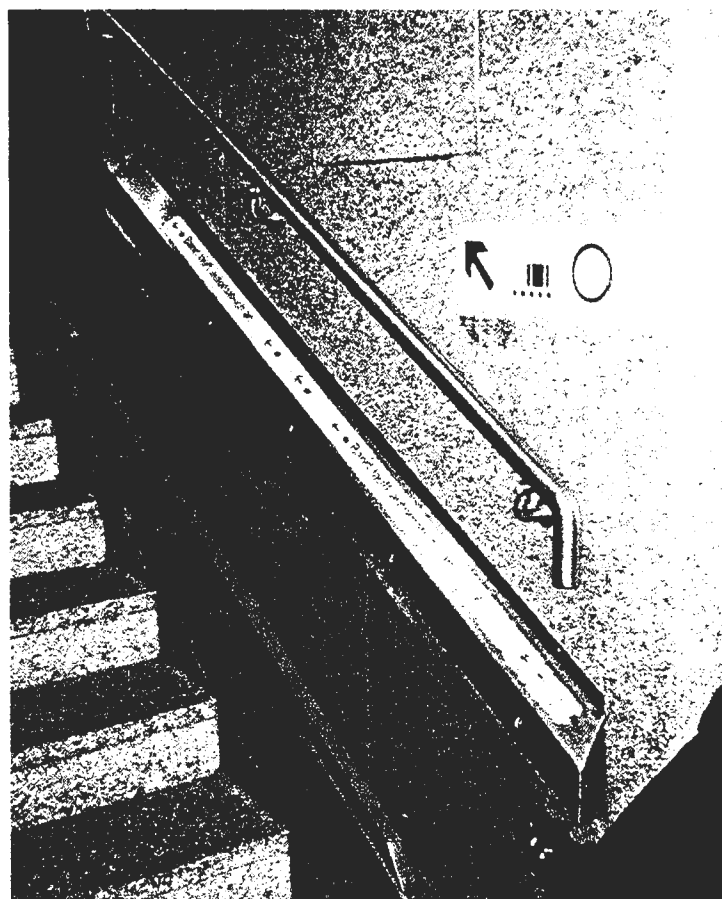

Figure 8.6/ Luggage Carrying Belt at Cologne Rail Station

9/ ENGLAND

9.1/ London

A brief visit to London permitted few observations and no facility visits. However, we did observe the system in action, visited the Docklands line, and had a brief discussion with one of London Underground's line managers.

During the time of our visit, London Transport was in the process of a major reorganization with almost everything up in the air. The main idea was to reorganize, privatize if possible, and to upgrade the equipment. London, of course, has a very large transit system with an extensive system of subways (called Underground). The majority of the equipment and stations are fairly old, although many stations have been refurbished. Some rolling stock appeared quite worn out and was due for replacement (e.g., Central line). On the other hand, London Transport has many modern features introduced long ago. For example, the Victoria line trains were driven automatically from its inception over 20 years ago. Passenger information is excellent; for example, many stations are equipped with real-time passenger displays advising the arrival time and destinations of the next two or three trains.

The Underground system is extensive and the stations plentiful. There are plenty of systems maps around and every station has a local street map displayed at the entrance. The bus system is also extensive and visible with both traditional double-deckers, and more recently, local lines which are using smaller size, single-level buses. Part of the bus network was already privatized and it will be interesting to see how it all develops.

The price of tickets (magnetic strip) is relatively high; it is best to use a day pass available at a relatively good rate. We were advised that the running subsidies were low and the tickets should pay the real cost of travelling. On the other hand, the government promised major help with capital equipment purchases, and London Transport felt the new system will work much better.

London Transport was also talking about massive outside tendering of some of the maintenance functions, e.g., cleaning and vehicle rebuilding. Only time will show the results.

During our visit, we were able to briefly inspect the new Dockland railway, a relatively new automatic train system (see Figure 9.1 for system's plan). The Dockland system has received quite a lot of criticism, mainly due to problems with the train control system. As a result, the driverless trains use "train captains" (Figure 9.1.2) to intervene, as required.

In our presence, a train overshot the station and the captain corrected the position using manual override. As these problems were happening quite often, the Dockland lines were being refitted with the new drive control system during our visit. The trains themselves are quite pleasant and contain on-board "next station" signs.

9.2/ Herga

A brief visit was made to Herga Electric Limited located in Bury St. Edmunds. This company patented and is manufacturing a unique fibre-optic sensor (Hergalite). The sensor (see Figure 9.2.1) is a thin glass fibre with special coating. A plastic spiral is placed outside (Figure 9.2.2). The plastic spiral permits local bending (micro bending) of the fibre, when pressure is applied and the light in the fibre is guided out of the core and dispersed in the outer layer. In practical applications, a coded light signal is sent through the fibre and monitored at the other end. A very small deflection (in the order of 0.001 inch) can be detected. As the amount of light dispensed is proportional to a degree of bending (or localized force applied), a system can be tuned electronically to various pressures.

The fibre-optic sensor can be located inside mats, edges, etc., thus creating many possible applications. As the sensor does not carry current and is corrosion resistant, it can be immersed in liquid.

The Herga company produces many versions of switches, safety mats, safety edges, contact sensing bumpers, and low-profile sensors. For example, a Hergalite sensor placed along the edge of glass can prevent the power window from closing on somebody's fingers.

There are possible transit applications of Hergalite. For example, many vehicles are at present equipped with sensing mats for door opening or passenger counting. The current step-on mats contain two flexible metal plates with a plastic spacer. The pressure applied will connect two surfaces and the current passing is detected. Although the metal plates are encased in rubber, they will become inoperative with water ingress. A fibreglass sensor mat will fulfill the same function, in a better way (sensitivity can be easily adjusted), would not be bothered by water, and can be manufactured inexpensively.

Another most obvious transit application is a sensitive door edge. Such an edge is capable of detecting a very small localized deflection, e.g., a piece of clothing.

Herga is also working with London Underground on detecting a person falling into the gap between the platform and train. In some older stations the gap is considerable.

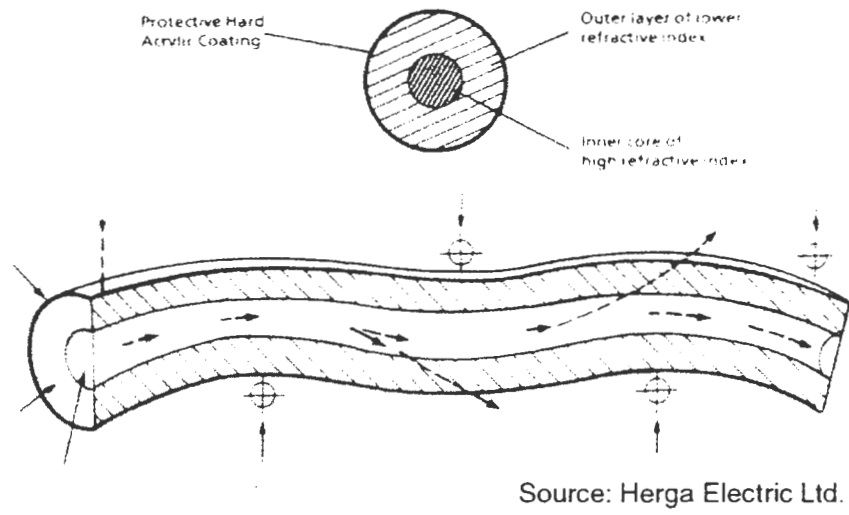

Figure 9.2.1/ Herga Sensor Principle

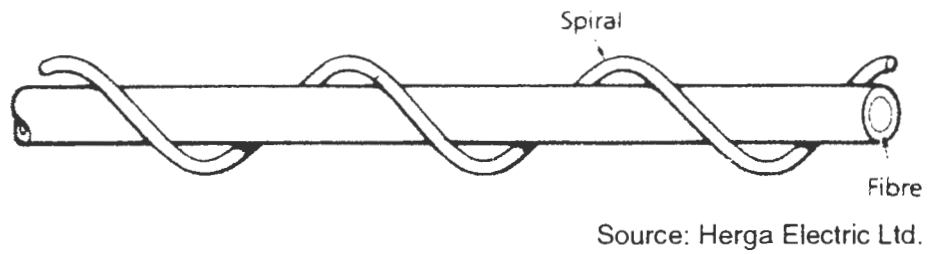

Figure 9.2.2/ Herga Sensor Construction

9.3/ Manchester Light Rail Show

A brief visit was made to the second International Light Rail Exhibition held in Manchester. Unlike some large U.S. shows, there were no actual vehicles (with the exception of Manchester's own examples) but there were plenty of models, components, and photographs. The show was widely attended and most European transit manufacturers were exhibiting.

There were two main subjects which attracted my attention: low-floor cars and the use of composite materials in transit.

The low-floor light rail cars were initially introduced in Europe in 1984. Unlike North American developments which appear to be driven mainly by political considerations (eg., disabled access), the European motive was mainly loading efficiency at the stops. The initial models started with lower centre sections with steps or an incline toward the ends of the car. Some current models have almost all low-level floors with relatively insignificant inclines. The new designs ordered from 1990 onwards specify three-phase AC motors, which are smaller than the usual DC counterparts.

In order to make the low floor possible, the bogies had to be completely redesigned and a lot of equipment moved to the roof. The bogies themselves are perhaps most interesting with unusual drive arrangements with some motors located directly on the wheels.

Some examples are shown in Figures 9.3.1 and 9.3.2 (ABB – SOCIMI manufactured cars for Milan), Figures 9.3.3 and 9.3.4 (Bombardier design), and 9.3.5 and 9.3.6 (another Bombardier design) and Figures 9.3.7 and 9.3.8 (V.O.V. commissioned design).

The low light rail cars are available now from quite a few manufacturers, but due to the small series and new construction, the prices are quite high. For those interested in the topic, there was an excellent article published in November 1991 *Railway Gazette International*, "Low-floor Development Out of Control."

During the last few years, about half of new streetcar and bus orders were low-floor, but the expectation is that the majority of new orders from now on will be low-floor.

The other trend clearly seen at the show is a greatly increased use of composite materials for transit vehicles. The present application of composite materials in front ends, interior panels, and doors (Figure 9.3.9), etc. is part of an increased trend to structural components including whole bodies.

It remains to be seen how this trend will develop, but the experts claim that almost the total vehicle, including suspension, can be made from composites at a lower cost and weight compared to their metal equivalents.



Source: SOCIMI (Societa Costruzioni Industriali Milano)

Figure 9.3.1/ Milan Low-Floor Car Next to Older Model

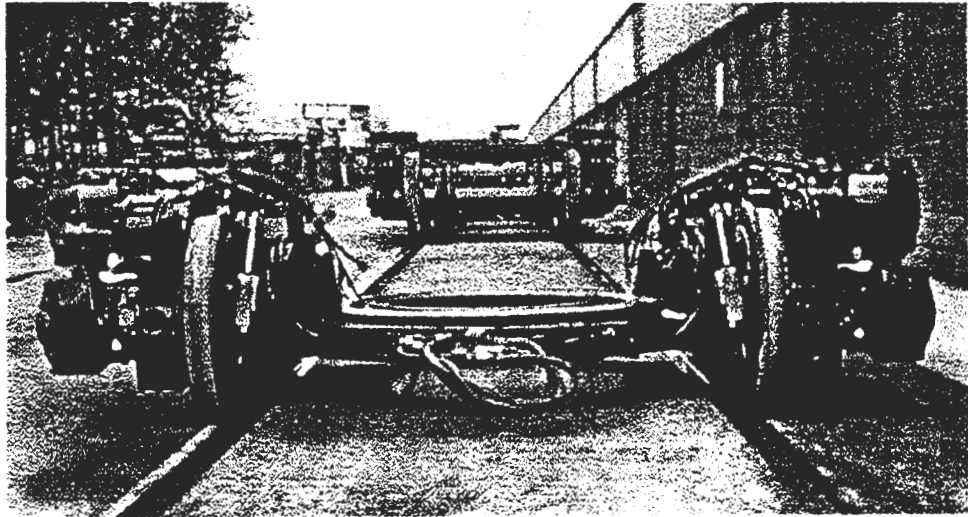

Source: SOCIMI (Societa Costruzioni Industriali Milano)

**Figure 9.3.2/ Bogies for the Above Cars
(low-floor in foreground)**



Source: BN Division of Bombardier Eurorail

Figure 9.3.3/ Bombardier LRV 2000 Low-Floor Car

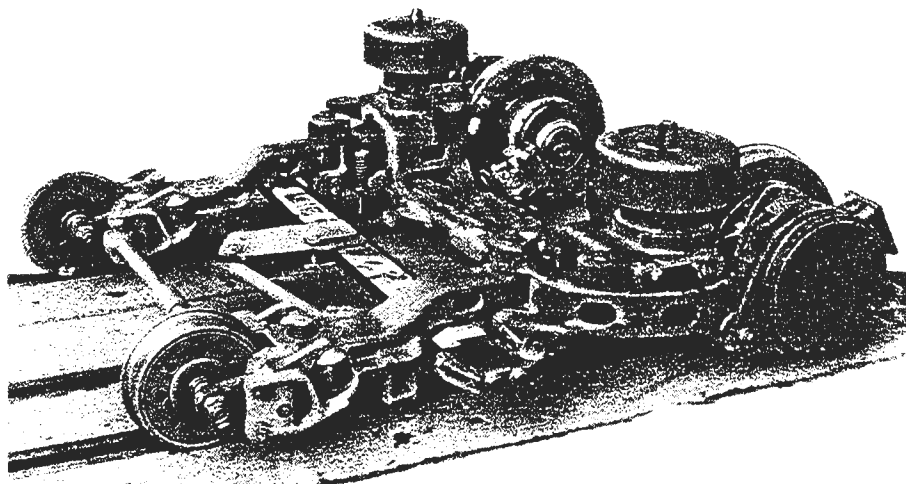

Source: BN Division of Bombardier Eurorail

Figure 9.3.4/ Bogie for Bombardier LRV 2000 Low-Floor Car

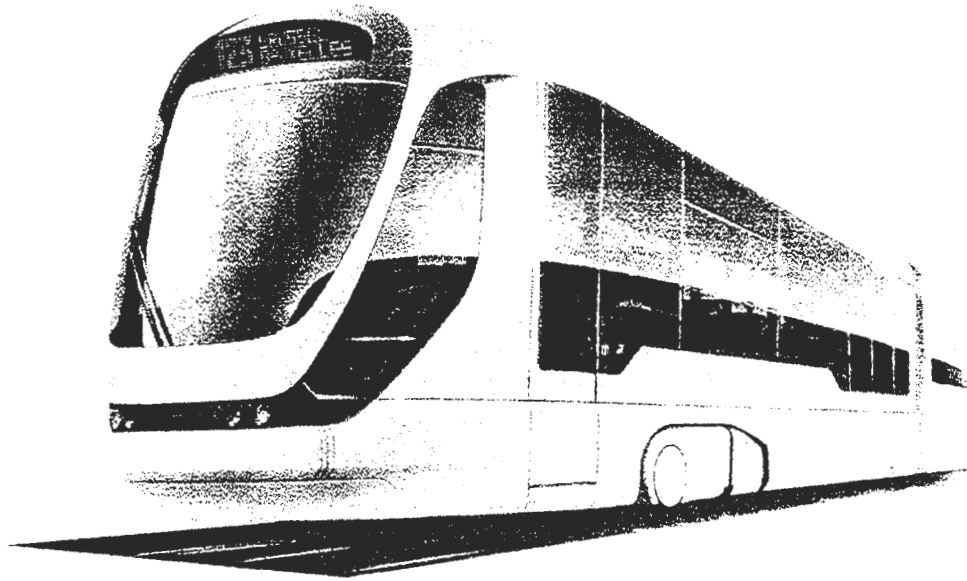

Source: BN Division of Bombardier Eurorail

Figure 9.3.5/ Bombardier Train 2000 for Brussels

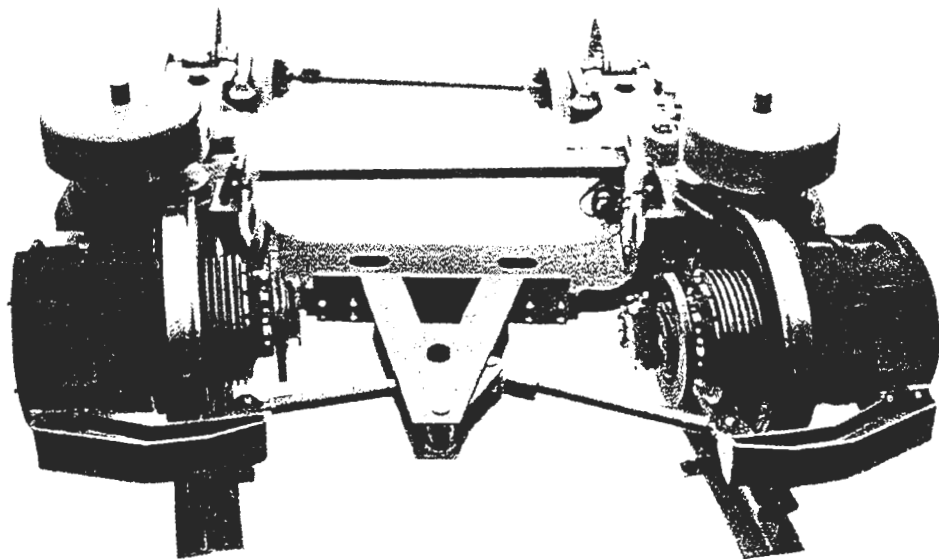

Source: BN Division of Bombardier Eurorail

Figure 9.3.6/ Bogie for Bombardier Train 2000 for Brussels



Source: VÖV - Niederflur-Stadtbahn

Figure 9.3.7/ German Low-Floor Car

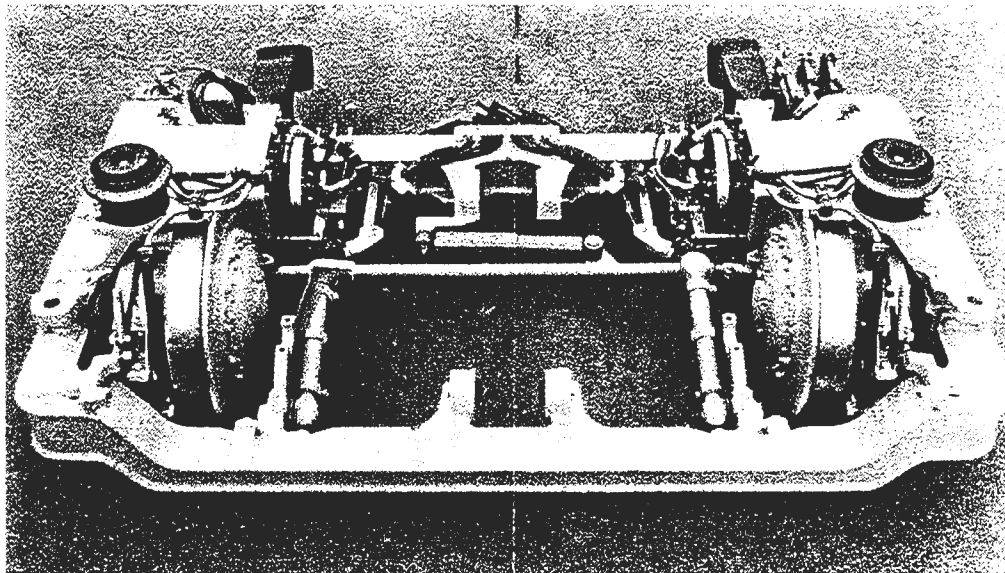

Source: VÖV - Niederflur-Stadtbahn

Figure 9.3.8/ Bogie for German Low-Floor Car

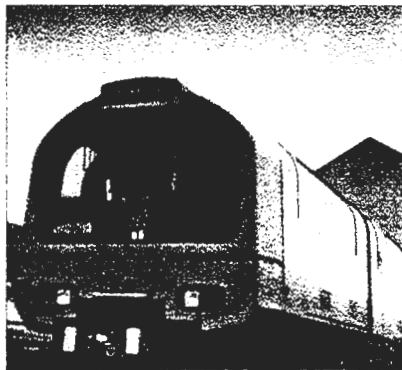
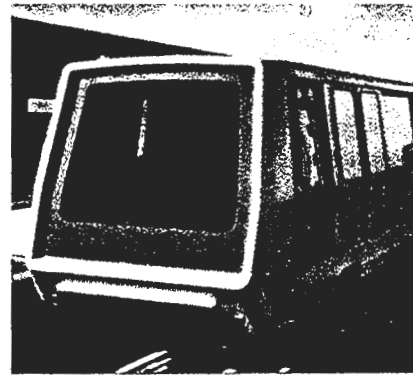
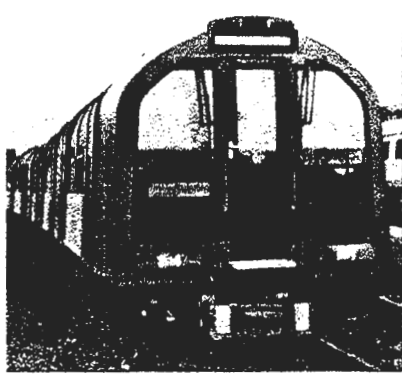

Source: Strachan & Fox Composites Ltd.

Figure 9.3.9/ Composite Applications

10/ CONCLUSIONS AND RECOMMENDATIONS

In many areas, European transit systems are more advanced than North American ones.

The most important benefits appear to stem not just from applications of specific technologies, but from standardization and resulting economies of scale, as compared to North American developments, which are usually property-specific.

In general, there appears to be much stronger cooperation between the transit associations and governments. More importance is placed on the quality of service and a great effort is made to provide convenient, regular, and inexpensive transit services. In many cities, transit is a mode of choice even for the very well to do as it is often more convenient and certainly cheaper than a private car. Emphasis is placed on frequency and regularity of service and excellent passenger information is available at stations, bus stops, and on board the vehicles.

In general, the vehicles appear to be a little more spartan (for example, most have ventilation as apposed to North American air conditioning) and many improvements are driven by efficiencies as apposed to politics. For example, the impetus for the low-floor vehicle designs was primarily the goal of reduced boarding time (and hence shorter dwell at stops) rather than to meet legal requirements such as the ADA.

The fares are often lower than in North America and there is a variety of differently priced tickets available.

Although various technologies are quite advanced in many areas, excellent results are achieved by less sophisticated, no-frills solutions. These are usually available off the shelf, mainly as the result of standardization.

Some transit systems are run by private companies and the staffing levels are often considerably lower than in North America. The personnel appear to be very well trained, the result of European tradesman training programs.

In the technology area, there appears to be greater understanding and acceptance of new ideas. The new equipment is usually developed by consortia which include transit users, private technology companies, and others such as transit associations and various appropriate government bodies.

The financing is shared and appears to be more readily available than in North America.

The ITIME task force discussed the trip findings and recommended three specific areas for immediate action. These are listed below:

- 1/ Standardization: particularly for communications (on board and vehicle to outside), on board hardware, and data base format.
- 2/ The installation and use of automated brake/front suspension testing dynamometers in existing inspection lanes equipped with a pit. This testing equipment, which is readily available, verifies the condition of bus braking and front suspension systems. Test results are automatically entered in a central data bank for analysis and for future reference. Unsafe conditions are immediately identified and corrective action can be scheduled. This procedure eliminates the need for manual inspections, and also eliminates the need for a test drive, usually required after all major brake repairs.

The installation of this equipment is relatively straightforward and needs only minor modifications to existing inspection lanes. The addition of power module (engine and transmission) diagnostic equipment is also recommended to enhance the brake/suspension testing device. The addition of this system, however, requires additional facility modifications.

Two dyno demonstration projects have been funded: German equipment in Ontario (this equipment was installed in March of 1993) and a French-made unit in New York (expected in the summer of 1993).

- 3/ The installation of robotic vehicle cleaning systems for rail car applications. This system identifies the vehicle type and automatically adjusts for under-chassis cleaning. Like the bus testing equipment discussed above, this robotic cleaning system reduces labour and improves safety by removing workers from dangerous work environments.

This project was funded by FTA for Los Angeles in 1991/92 but was not started due to lack of local funding. Since then, discussions have taken place with three major U.S. rail properties and it is hoped that a demo property will be found in the not-to-distant future.

Technologies recommended for future application include:

- Fibre optics for door controls, sensitive door edges, and for passenger counting applications;
- Robotics for bus fuelling operations;
- Electric propulsion systems for buses to reduce emissions;
- Robotics for facility and vehicle cleaning;
- Automation of facility management operations;
- Central water treatment in maintenance facilities;
- Computerized parts storage.

APPENDIX

Organizations and Contacts

FRANCE

Scott KUNITANI

Chef de Projet

SOPRETEU

Serge Guibereau

Ingénieur en Chef Adjoint

Chef des Ateliers de Révision du Matériel sur Pneumatiques

SOCIÉTÉ FRANÇAISE D'ÉTUDES ET DE RÉALISATIONS DE TRANSPORTS URBAINS

5, avenue du Coq - 75009 Paris - FRANCE - Tél. : (+33) 1 40 16 61 00 - Fax : (1) 40 16 61 04 - Telex : 281 239 F

Département Matériel Roulant Ferroviaire
16, Rue Jean-Jacques Rousseau
94120 Fontenay sous Bois
Téléphone : (1) 40 06 73 01



Jean-Daniel Mayer

Département Environnement et Sécurité
Propreté - Robotisation

Michel Robert

Département du Matériel Roulant Bus
MEB / Méthodes

Forum des Halles
Cidex n° 165
75045 Paris Cédex 01

Téléphone : (1) 40 02 46 07

40 46 42 30



34, Rue Championnet
75860 Paris Cedex
Téléphone : 49 25 51 31
Télécopie : 49 25 65 39



Département du
Matériel Roulant Ferroviaire
Révision MP

de la part de

Alain PONTET

16, Rue Jean-Jacques Rousseau
94120 Fontenay-sous-Bois
Téléphone : (1) 40 06 73 33
Télécopie : (1) 40 06 73 57



FRANCE

Jean-Pierre VEUNAC
Directeur Général



A BM Group Company

FRANÇOIS LONGIN
CHEF DES VENTES



SOCIÉTÉ DES TRANSPORTS EN COMMUN
DE L'AGGLOMÉRATION DE BAYONNE
Bo de l'Antiquaire (entrée échangeur Lachepaillet, R.N. 10) - 64100 BAYONNE
B.P. 451 - 64104 BAYONNE Cedex - Tél. 59 52 59 53 - Télécopie 59 52 03 75

Allée des Forges - B.P. 935 - 65009 TARBES CEDEX (FRANCE)
Tél. : 62 38 44 00 - Télécopie : 62 37 18 92

Agence Ile-de-France
20, Rue des Dames - Zone Industrielle - 78340 LES CLAYES-SOUS-BOIS
Tél. : (1) 34 81 15 33 - Télécopie : 695 180 SEP/BM - Télécopie : (1) 30 54 11 12



J. Germain

Robotique,
Automatisme
et Techniques

Rémi THEVENET



A BM Group Company

JACQUES THEZE
DIRECTEUR TECHNIQUE



27 RUE DU PORT - 92022 NANTERRE CEDEX
TEL. 47 21 37 14 - TELECOPIE : 47 21 37 98

Allée des Forges - B.P. 935 - 65009 TARBES CEDEX (FRANCE)
Tél. : 62 38 44 00 - Télécopie 62 37 18 92

Cécile Yu Liang
Assistant



48 à 56, rue Barbès
B.P. 531
92542 Montrouge Cedex
France
Phone : (33-1) 49 65 70 70
Télex : MTRAN 632759 F
Telefax : (33-1) 49 65 74 97

VIENNA



DIPL.-ING. PETER ANDREISCHITZ



DIPL.-ING. GERHARD MARTL

Leiter der Abteilung
Wagentechnik - Schienenfahrzeuge

WIENER STADTWERKE
VERKEHRSBETRIEBE
Wagentechnik -
Schienenfahrzeuge

Favoritenstraße 9-11
A-1041 WIEN
Telefon (0222) 501 30-3217 DW

WIENER STADTWERKE
VERKEHRSBETRIEBE
Wagentechnik -
Schienenfahrzeuge

Favoritenstraße 9-11
A-1041 WIEN
Telefon (0222) 501 30-3211 DW

MUNICH

Wolfgang Ruth
Dipl.-Ing.
Versuch

ZEUNA  STARKER

Zeuna Stärker GmbH & Co KG
Biberbachstraße 9
D 8900 Augsburg 1
Telefon 08 21/41 03-512
Telefax 08 21/41 03-599

Rainer Kolodzie

Dipl.-Ing. (UNIV.)
Product Market Manager
Thermosystems

Webasto

Webasto AG Fahrzeugtechnik
Postfach 80 · Kraillinger Straße 5
D-8035 Stockdorf
Telefon (089) 8 57 94-0 (-543)
Telex 523 647 webas d
Telefax (089) 8 56 19 18

STUTTGART

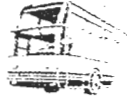

NEOPLAN

Bob Lee

Dipl.-Ing.
Direktor
Mitglied der Geschäftsleitung

Gottlob Auwärter GmbH + Co.
Vaihinger Str. 118-122
D-7000 Stuttgart 80 (Möhringen)
Telefon (07 11) 7 8 35-219
Telefax (07 11) 7 80 16 96
Telex 7 255 871

DR. KLAUS KREUTZ

International Project-Manager



Privat:
Forlenweg 17
7536 Ispringen-Pforzheim
Telefon (072 31) 8 9194

Gottlob Auwärter GmbH + Co.
Vaihinger Straße 118 – 122
Postfach 810140
7000 Stuttgart 80 (Möhringen)
Telefon (07 11) 7 8 35-0 (629)
Telex 7 255 871
Telefax (07 11) 7 80 16 96

COLOGNE

Dr.-Ing. Adolf Müller-Hellmann

Geschäftsführer
Technik

**Verband Deutscher
Verkehrsunternehmen**



Kamekestraße 37-39, 5000 Köln 1,
Telefon 02 21 / 52 50 64-65, Telefax 51 42 72, Telex 8-881 718

Privat: Auf der Halde 22, 5060 Bergisch Gladbach 1,
Telefon 0 22 04 / 5 70 93

LONDON

Victoria line



London Underground Limited
Western House
237/39245 Oxford Street
London W1R 1LF

John A Self
General Manager 518 1293
Telephone 071-227-6293
Fax 071-734 1831



T R A N S M A R K

Enterprise House 169 Westbourne Terrace London W2 6JY
Telephone (0)71-723 3411 Telex 8953218 BRTMK G Facsimile (0)71-258 1938

G. HORNBY CEng
Senior Manager, Projects



HERGA

herga

Richard C. Chatham
SALES & MARKETING DIRECTOR

Herga Electric Limited

Northern Way,
Bury St. Edmunds,
Suffolk, IP32 6NN
England.

Telephone: (0284) 701422
Telex: 81378
Fax: (0284) 753112



Innovation Quality Service

herga

Colin A. Botting
CHIEF DESIGNER
ELECTRONICS

Herga Electric Limited

Northern Way,
Bury St. Edmunds,
Suffolk, IP32 6NN
England.

Telephone: (0284) 701422
Telex: 81378
Fax: (0284) 753112



Innovation Quality Service

herga

Herga Electric Limited

Northern Way,
Bury St. Edmunds,
Suffolk, IP32 6NN
England.

Telephone: (0284) 701422
Fax: (0284) 753112



Innovation Quality Service

Innovative Technology to Improve Maintenance Efficiency (I-TIME) - Field Trip Report -

Performance Monitoring & Vibration Analysis of AC/DC Electric Motors

Reference: I-TIME Task Force technology review performed at CSX Locomotive Shop in Huntington (West Virginia) on February 17th 1993 :

- Performance Monitoring of AC / DC Electric Motors,
- Vibration analysis of Electric Motors and Mechanical Components

The purpose of this trip was three-fold: to evaluate an electric motor monitoring system, to attend a demonstration of vibration analysis equipment and to visit the CSX Locomotive Shop in order to identify any technologies that might be transferred to public transportation so as to improve maintenance efficiency.

In Huntington, I was met by Robert M. Jones, Ph.D., principal application engineer for SKF Condition Monitoring. Mr. Jones was there to demonstrate the electric motor monitoring system that is promoted by SKF.

The monitoring system consists of a data collector / analyzer (SKF's Microlog CMVA10), a computer-assisted condition monitoring software (SKF's PRISM²) and a signal conditioner developed and patented by Performance Technologies Inc. The total cost of this equipment is approximately \$30,000 US. This equipment is able to provide nonintrusive, on-line monitoring of electrical motors by simply hooking onto one of the motor's lead wires. The condition of the motor is provided by Motor Current Signature Analysis (MCSA). MCSA is carried out by extracting information from the motor lead wire, conditioning it electronically and analyzing it with standard analysis hardware or software. Motor current signatures, obtained in both time and frequency domains, provide motor condition indicators that can be trended over time to provide early indications of degradation and are the basis of any predictive maintenance system. MCSA can be performed on both AC and DC motors.

At the CSX Locomotive Shop, we were greeted by Ben McLung, Superintendent of the traction motor and wheel assembly overhaul division. Mr. McLung first took Mr. Jones and me on a tour of the Motor and Wheel Shop to provide us with an overview of the overhauling process before the equipment demonstrations.

Following the visit, a demonstration combining both motor vibration analysis and condition monitoring equipment was given. The vibration analysis equipment is located at the end of the traction motor assembly line. Although components and subassemblies are tested all throughout the overhaul process, all motors are

Innovative Technology to Improve Maintenance Efficiency (I-TIME) - Field Trip Report -

Performance Monitoring & Vibration Analysis of AC/DC Electric Motors

bench-tested before being released. Each motor is run for approximately 105 minutes. For this reason, three motors are tested simultaneously. Each motor is hooked up to its testing equipment and then run through a series of different tests. The motors are checked for excessive overall vibration amplitude (no more than 0.3 inch per second) and temperature. Two of the test consoles are GE Traction Motor Test Consoles (TMC42377 Rev 3, 028-71602-5311); the third was built by Phenix Technology (TM1800-72D). The two (2) GE consoles are equipped with an automatic safety shut-off in case of excessive vibration. However, the Phenix is not and must be monitored during the process. All overhauled motors are covered by a two-year (2) warranty and of the 1,500 motors produced annually, less than 2% need to be reworked under warranty.

Mr. Jones then proceeded with the demonstration of the electric motor monitoring system. The system was demonstrated in the assembly line's test area during one of CSX's vibration test. The MCSA requires both the data collector / analyzer and the signal conditioner. The signal is picked up by a standard AC / DC current clamp, run through the signal conditioner and recorded by the data collector. The data collector can be configured either manually or by downloading the setup information from a computer. The demonstration was performed on a DC traction motor. The test itself requires but a few seconds, once the data collector is configured. Through the use of preset warning and alarm levels, condition analysis can be carried out directly by the operator with the help of the data collector. Data collected can also be analyzed with the help of the PRISM² condition monitoring software that was not demonstrated at such time.

After the demonstrations, Mr. Jones and I were taken on a tour of the rest of the facilities in order that I might look for any technology that could be used to improve maintenance efficiency.

The following are my comments on the equipment and technologies reviewed:

AC.Motor Current Signature Analysis:

- The testing of AC motors must be performed at or near full load and thus requires that the motor be tested either in service or on a dynamometer, under controlled load. This requires the use of additional equipment or on-board testing procedures that demand that the motors be loaded enough to test.

Innovative Technology to Improve Maintenance Efficiency (I-TIME) - Field Trip Report -

Performance Monitoring & Vibration Analysis of AC/DC Electric Motors

- Tests and data cumulated to date have been able to analyze the motor's slip to identify damaged rotor bars and electrical breakdown within the motor.
- Although Mr. Jones is sure that the internal condition of an AC motor can be evaluated with some degree of confidence, additional empirical data needs to be studied to gain confidence. Such data is currently being collected by Mr. Jones.
- The tests and data cumulated to date seem to confirm that MCSA has the capacity to evaluate the internal condition of AC motors without needing to disassemble them. This nonintrusive means of determining also seems to be able to assist in determining possible future failures with the help of predictive trending softwares. The technology would help reduce the cost of periodic inspections and greatly reduce the cost of overhauling motors by allowing the motor to be taken out of service before it fails through predictive maintenance. However, it would be wise to accumulate empirical data on AC motors to determine the current signature patterns of the different failure modes and the appropriate warning and alarm levels for predictive maintenance. This work could be conducted in cooperation with SKF as a pilot project.

DC Motor Current Signature Analysis:

- The testing of a DC motor does not require it to be under load to provide adequate signal.
- Although the tests that have been conducted have revealed that current signature is altered by a break in the insulation of the rotor, the empirical information gathered to date on the degradation of a DC motor's insulation is insufficient and inconclusive. The behaviour of the overall RMS amplitude over time in an DC motor has not yet been determined and no hypothesis has been put forward as to its expected behaviour.
- Mr. Jones is currently conducting tests with the CSX Locomotive Shop and collecting empirical data to try and validate the theory he has put forward.
- The information being gathered now reflects the condition of overhauled motors. Tests should also be conducted on new motors to be able to trend the current signature of the entire life span of a motor.

Innovative Technology to Improve Maintenance Efficiency (I-TIME) - Field Trip Report -

Performance Monitoring & Vibration Analysis of AC/DC Electric Motors

- More systematic testing should be performed to determine the influence of the different motor characteristics on the motor current signature.
- More tests need to be carried out to determine the influence of the load on the current signature.
- Again, as with the AC motors, it would be wise to accumulate empirical data on DC motors to determine if the theory can be proven (is it possible to predict failure?) and what are the current signature patterns of the different failure modes and the appropriate warning and alarm levels for predictive maintenance. This work could again be conducted in cooperation with SKF as a pilot project.

AC/DC Motor Vibration Spectrum Analysis:

- The vibration spectrum analysis seems to be the most promising of all spectrum analysis that can be performed on either AC or DC motors.
- A single test is able to detect rotor imbalance, mechanical looseness and rolling element defects of the inner and outer races or of the balls. Identification of the defect and its current state of advancement is provided by the defect's frequency signature and amplitude.
- Vibration amplitude trending can be used as a major indicator in predictive maintenance relevant to rolling elements.
- Electric motor vibration spectrum analysis should be regarded as having a great potential to reduce the cost of maintenance, especially where the cost of rolling elements is significant or where there are important costs associated with the overhaul of equipment that has broken down (downtime, additional damage, ...).

Innovative Technology to Improve Maintenance Efficiency (I-TIME) - Field Trip Report -

Performance Monitoring & Vibration Analysis of AC/DC Electric Motors

DC Motor Overall Vibration Analysis:

- Overall vibration amplitude is a good indicator of the overall balance condition of the electric motor but is unable to identify the fault causing the imbalance. It is also unable to detect or trend rolling element defects.
- Overall vibration amplitude analysis is a good first step to test and ensure quality of overhauled components, if frequency spectrum analysis cannot be performed.

Other findings:

- The CSX Locomotive Shop has replaced the absorbant clay powders by a recycled fiber absorbant mat. The mat is made of natural fibers recycled from rags. CSX finds this mat more practical than powder to dry spills. The mat can also be laid down even before the work is started to absorb any spill that might occur during the work. The mat is also easier to pick up and dispose of.

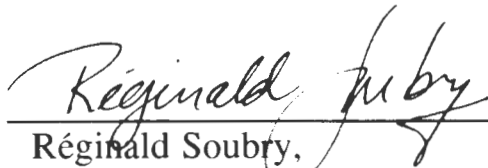

Réginald Soubry,
Project Engineer

Technical Services - Construction & Maintenance
Montreal Urban Community Transit Corporation



date

APPENDIX C

J. Schiavone
January 13, 1993

GRS TRACKER DEMONSTRATION
January 11, 1993
Grand Central Station
New York, N.Y.

On Monday, January 11, 1993, I traveled to Grand Central Station, New York, together with David Gunther, Maintenance Engineer, Baltimore MTA, to evaluate the GRS Tracker system. Tracker allows remote monitoring and diagnostics of GRS's processor based Vital Processor Interlocking (VPI) control system for rail switching/signaling equipment. The proprietary Tracker software is designed to operate on an IBM compatible PC, and continuously monitors various VPI stations throughout the rail system. A failure or warning condition at a remote site activates an alarm to alert a "maintenance dispatcher." The system locates the fault, communicates the corrective action in "simple English," and even provides the replacement part number for the circuit board(s) at fault. A technician is dispatched with the correct part in hand, which saves time and the need for higher-paid personnel. A laptop computer can also be used to troubleshoot failures at each location.

Tracker appears to be a "natural" addition to GRS's processor based switching/signaling system. In essence, it centrally monitors the self diagnostics already built into the processor based equipment and saves making two trips to the same location when making repairs. GRS claims that its Tracker technology can work with any processor based system. Proprietary rights to software, however, could create some "translation" problems.

David Gunther disputes GRS's claim that their Tracker remote-diagnostic system would reduce the need for higher-paid electronic technicians. Gunther claims that skilled technicians would still be needed to maintain the host of other complex electronic systems existing in the field.

Tracker certainly should be considered as an option to GRS's existing VPI system. The demonstration was informative. Beyond its immediate application, however, the "Tracker" concept represents what will someday be commonplace in transit maintenance. As more and more processor based electronic systems (stationary and mobile) are introduced to our industry, the possibility of "tracking" its "health" from a central location becomes a natural evolution.



TRACKER™

Overview

- **Allows monitoring/diagnostics of processor based systems from remote location**
- **PC based**
- **Initial Application to be GRS' VPI®**
- **Eventually to include all new GRS processor based products**
- **Possibility of working with competitor's systems**

Key Benefits

- **Reduced System Down Time**
- **Reduction in Skill Level Requirements for Maintenance Staff**
- **Reduction in Maintenance Staff**
- **Cost Effective**

Reduced System Down Time

- **Diagnose Problems from Office**
- **Required Replacement Boards known Prior to Field Trip**
- **Quick Diagnosis to at Least Board Level**
- **Periodic Monitoring of Health**
- **Laptop Version Available for Field/Mobile Use**

Reduced Skill Level Requirements

- "Expert" System Approach Determines Most Faults Automatically
- Eliminates Need for Indepth Knowledge of System Operation
- Menu Driven - Easy to Learn and Use

Reduced Maintenance Staff Requirements

- **Monitors Dispersed Systems from Central Location**
- **Maintenance "Dispatcher" Sends Out Technicians with Correct Replacement Parts**

Cost Effective

- **Uses Commercial PCs for Reduced Hardware Costs**
- **Monitors Multiple Systems**
- **User Configurable for Installation and Future Changes**
- **Can Monitor Variety of Systems from Single Tracker Unit**

DEFENSE LOGISTICS AGENCY
Visit by Jeffrey H. McCormick (SEPTA) and
Jeffrey Mora (UMTA)

As part of the TDC Innovative Technologies Task Force, the two Jeffs visited the Defense Logistics Agency (ex-US Army) Eastern Distribution Center in New Cumberland, PA on August 28, 1991. We met briefly with the Director, Lt. Col. Mike Yost and were given an extensive tour by John Bianco.

This 40 acre (1,686,124 square feet) new building is a consolidation of a number of older warehouses. It supplies about 300,000 stock items to military bases in the U.S. and around the world using truck, rail, air and ships. Approximately 10,000 orders are processed daily.

The staff is still in the process of making small refinements in the automation system and filling the vast storage space. A batch/key punch system is still being used in parallel with the new system to track items and perform accounting functions. The philosophy in designing the facility was to acquire the most reliable automation, not necessarily the most advanced.

A large number of computer controlled floor located towline carts (SI Handling Systems) and conveyor moved plastic tray containers shuttle supplies into both storage and shipment areas. The towline system is 5.3 miles in length and the conveyor system totals 4.5 miles. In the principal storage area, a group of 12 "cranes" which move vertically and in a back-front plane by operators are used to store and retrieve parts. The rack storage system has a total of 44,352 locations with an aggregate bin storage of 242,688 locations. In addition to these areas, there is a highly active item storage area which has 4,400 locations. Bar coding is used to locate storage areas, and identify items. Keyboards and screens are located on each of these cranes. The facility was built at a cost of \$210.6 million dollars, much of that cost being attributed to the materials handling equipment.

One robotics device is in use, an empty plastic tray stacker.

Pilferage is not a serious problem, according to the management. If the employees are treated well, pilferage stays at a negligible level. There are 2,700 employees and 4 unions in the facility.

The facility, itself, is vastly larger than even the largest transit authority. The requirements of the facility are to supply approximately a third of the globe with military hardware and replacement parts. From the standpoint of materials handling, the facility is a model of both proven automation and low cost machine-intensive handling. The applicability of materials handling on such a scale to transit in the United States is doubtful. However, individual components of systems utilized at the Defense Logistics Agency could be adapted to transit parts and supplies acquisition,

handling and inventory. This is particularly true in regard to the bar coding and reading equipment, computer inventory software and individual pieces of the material handling process. Much of the hardware installed in the building is off the shelf and available to transit authorities. Even though this is so, I doubt that many authorities are aware of its availability or existence. Seeing the equipment utilized for moving what are essentially commodities very similar to those commodities that we use in transit can give people ideas about applying that technology to their own operations. While we don't believe that there are a great number of directly transferrable technologies in use here, the warehousing operations are a demonstration of many existing capabilities all operating in unison at one location.

All in all, we feel the tour was definitely worthwhile and that if the rest of the task force ever meets in the vicinity of this DLA location, or its sister location in California, a tour should be arranged for the entire task force.



EASTERN DISTRIBUTION CENTER



NEW CUMBERLAND ARMY DEPOT
NEW CUMBERLAND, PA



MHK
ASSOCIATES

Morrison-Knudsen Co, Inc
Construction Manager
Facility Construction

Eaton-Kenway, Inc
Software
PCS/AOD Hardware

Harnischfeger Engineers, Inc
Material Handling Equipment
MHE/PCS Systems Integrator



EASTERN DISTRIBUTION CENTER

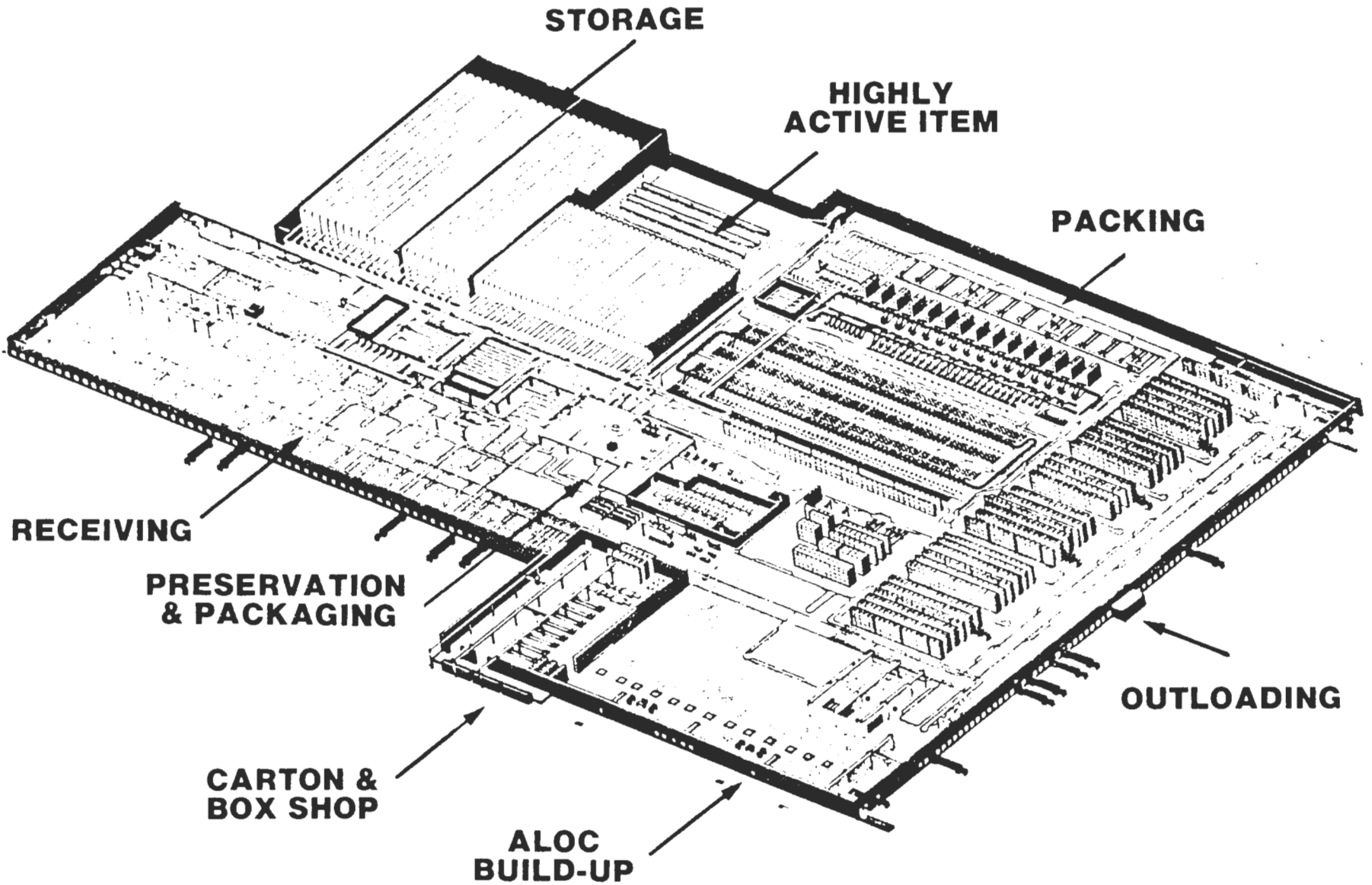

FACILITY FACTS

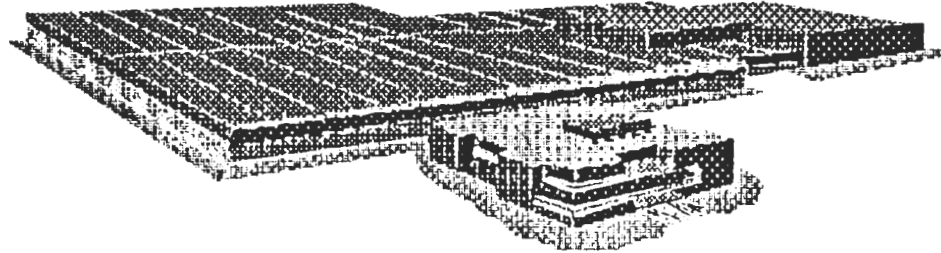

- Square Footage 1,686,124 square feet
- Towline System 5.3 miles
- Conveyor System 4.5 miles
- Receiving Doors 54
- Outloading Doors 68
- Rack Storage 44,352 locations
- Bin Storage 242,688 locations
- Highly Active Item Storage 4,400 locations
- Number of Sortation Chutes 368
- Indoor Railcar Staging 240 feet

NCAD OPERATIONS CENTER

2 Story Facility
116,120 SF (Gross)
First Floor - 100 Personnel
Second Floor - 400 Personnel
Approximate
Total - 500 Personnel

D/Supply, D/QA and Other
Support Staff Offices
Meeting Rooms/Credit Union/
Bank/Blind Vending Area
Cafeteria/Kitchen
293 Seating Capacity
1022 Serving Capacity

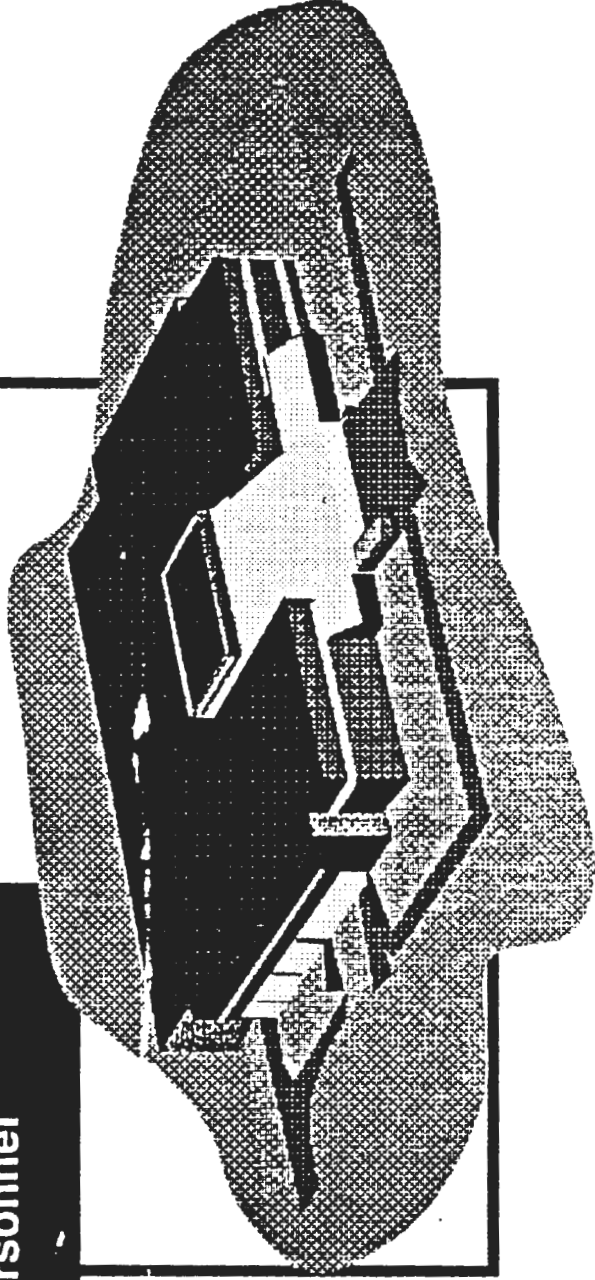

PROJECT PHASES AND FUNDING (\$M)

MCA OPA OMA

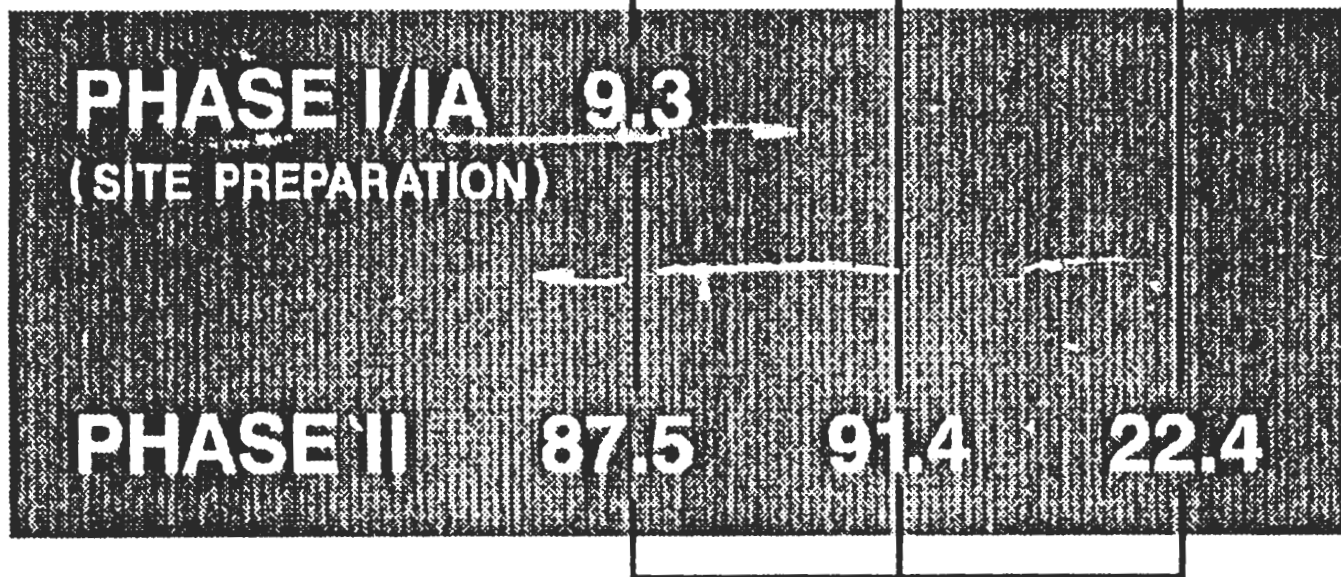

TOTAL 210.6

RE-PROGRAMMING	4.7	2.3	-
PCS INTEGRATION & FY90 COE COSTS	-	-	3.5

EASTERN DISTRIBUTION CENTER

COMPUTER SYSTEMS HIERARCHY

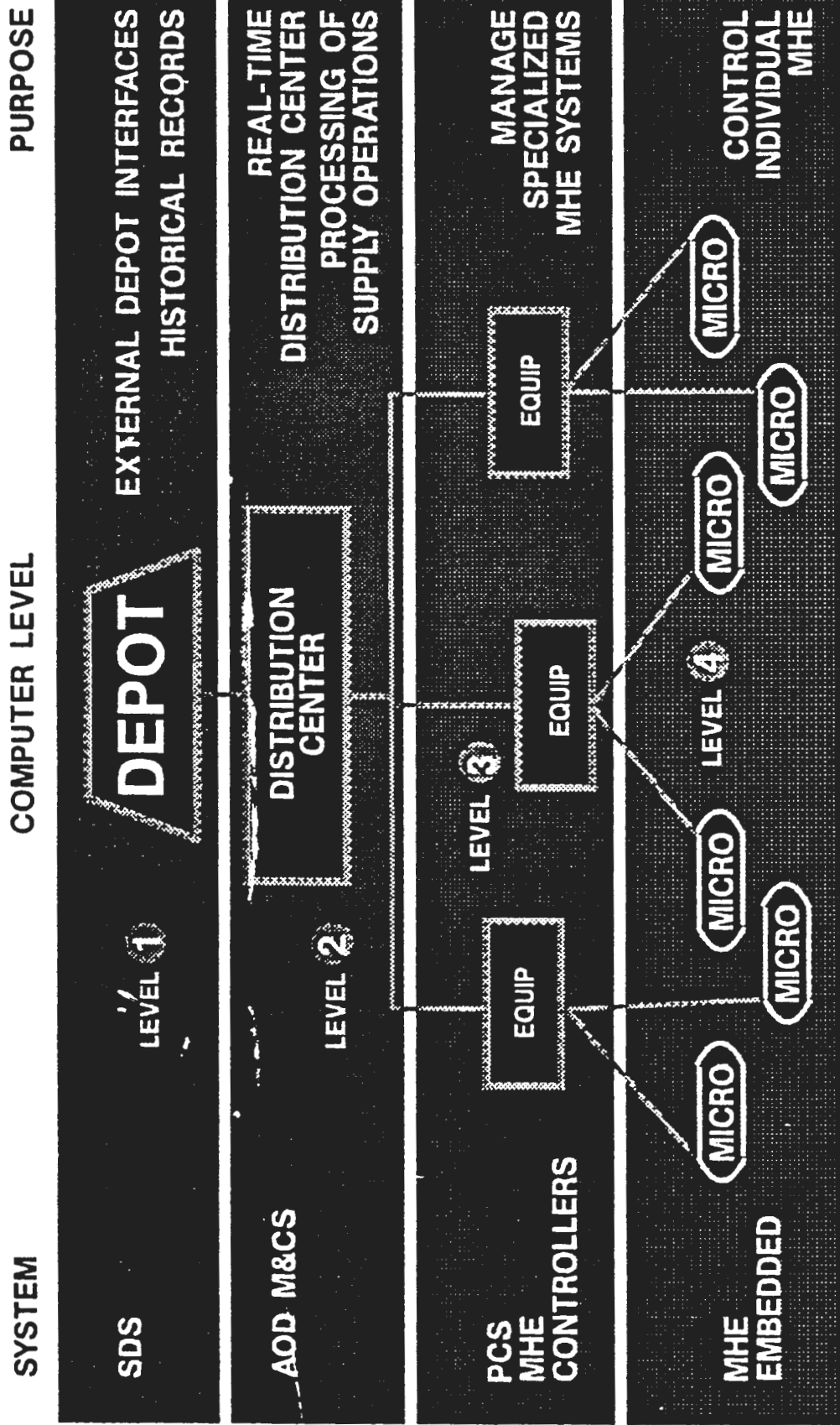

MANAGEMENT & CONTROL SYSTEM FEATURES

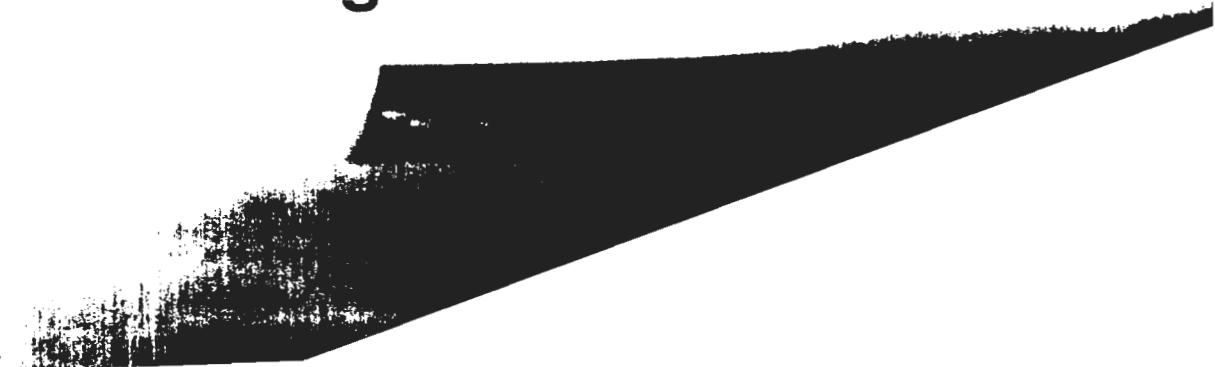
- **Quantity by Location**
 - **Validation of Weight/Cube**
 - **Tracking of Work-In-Process**
 - **Real-Time File Updates**
 - **In-Line Cancellations**
 - **Shipment Planning**
 - **PPC**
- 

PROCESS CONTROL SYSTEM FEATURES

- ❖ **Equipment Control**
- ❖ **Operator Interface**
- ❖ **Work-In-Process Balancing**
- ❖ **Pick Optimization**
- ❖ **Coordinate/Control Packing Operation**
- ❖ **Transaction Processing**
- ❖ **Tracking Within MHE System**
- ❖ **Real Time Inquiry Capability**

MHK ASSOCIATES

AOD COMPUTER SYSTEM

- **One Amdahl 5868 Uniprocessor**
- **Shared Disk**
- **11.6 MIPS**

PROCESS CONTROL SYSTEM HARDWARE

- **Single Family of
DEC VAX Computers**
- **Located in the EDC**
- **Three Processors
with Star Cluster**

ITIME TASK FORCE VISIT TO SANDIA NATIONAL LABORATORIES

Albuquerque, NM

by

Bob Graham

and

Wojtek Wiercienski

September 15 and 16, 1993

Visit organized by Dr. D. Caskey – Sandia Labs

Report prepared by W. Wiercienski

INTRODUCTION

Sandia National Laboratories are owned by the Department of Energy (DOE) and operated by the AT&T organization.

The main facility is in Albuquerque, NM with a smaller facility in Livermore, CA and field offices in Tonopak, Kauai and Amarillo.

In 1991, Sandia had a \$1240 million budget and employed 8600 people. The technical staff alone numbered 3645, with over 2800 having postgraduate degrees.

Sandia performs research into all aspects of nuclear weapons from design to safe disposal, and as such deals with an extraordinarily large range of subjects. Facilities and skills are available to perform virtually any engineering research and testing activity. It should be noted that the testing facilities are fully supported by manufacturing, computing equipment, and skilled staff.

Recently, U.S. Congress directed various laboratories to convert some of their efforts to commercial applications. The purpose of our visit was to establish if such possibilities exist in connection with the transit industry.

Although our visit was extremely brief, it is clear that numerous opportunities exist both in transit and in the field of general transportation.

The following report describes visits to various departments and lists the various ideas suitable for possible joint projects.

Overview of Sandia

A welcome and an overview of the Sandia activities was provided by Mr. James Kelsey, Director of the Transportation Center. He and his staff described the working of the Sandia organization and indicated that Sandia is willing to work with the transit industry on any projects where they can contribute useful expertise.

As the name indicates, the Transportation Center is responsible for the transportation of nuclear related materials and parts. Due to the nature of the cargo, a great deal of care is necessary to assure their safe transport. The cargo may be carried using road and rail vehicles, and aircraft.

The center has input into vehicle design and conducts physical testing including crash testing. They have also designed safety systems which provide real-time location and communication with transport vehicles. One such location system (Star Base) was demonstrated to us and is briefly described below.

Star Base Demonstration

Star Base (Security Tracking and Response Base) is a satellite based system which keeps track of the location and condition of government-owned vehicles that transport sensitive cargo.

The last upgrade was carried out in 1992, and consequently the technology is very much state of the art. The main display shows the map of the United States with small icons, which indicate the location of vehicles or convoys. Smaller scale maps are available and the level of the detail can be very high if requested. The hardware is of the "touch screen" variety and the system is very simple to use.

The system communicates via satellites using a Global Positioning System (GPS) for location information. The system is built in a redundant manner (i.e., there are multiple backups available to provide continuous functionality).

The system is very easy to use and requires no programming knowledge. The level of detail can be chosen in real time. The location data base appears to be very detailed.

The on-board hardware checks the condition of various vehicle systems and communicates with the central operation. Communication with drivers is also available.

The Star Base system is in effect a very large version of an AVL system. It has many potential transportation applications. For example, it can be used to locate commercial vehicles anywhere in the U.S.A. Details of the map appear to be more than sufficient to locate transit, police or other transport vehicles. The software is extremely easy to use and it may be worthwhile to demonstrate its use in suitable civilian (e.g., paratransit) applications.

Robotics, Vehicles and GPS Activities

Sandia has developed a series of intelligent remotely controlled robotic vehicles. The vehicles range from one-foot square to large trucks.

The vehicles are controlled using Sandia developed intelligent (KRITIC) software. The software permits not only operator input, but also sensor input and will modify operator or preprogrammed commands in real time in order to avoid collision with newly found obstacles.

The prototypes observed are primarily intended for military applications, and can be equipped with a variety of special sensors (e.g., to detect intruders) and weapons as required. In addition, suitably equipped vehicles could have important civilian applications. For example, these vehicles could be used as delivery or part pickup

vehicles in a factory or large transit facility where the operator can issue a top level command with the vehicle using its own intelligence to navigate in dynamically modified space.

Such vehicles can also be used to clean a facility or even the interior of a transit vehicle.

We were given a tour of the labs and a demonstration of a medium-size vehicle. We further discussed the possibility of building a robotic vehicle, which could be used as an intelligent safety device in a road repair situation.

Discussions have also taken place on the subject of commercially available GPS systems which have been recently evaluated at Sandia. Sandia produced a report which may be of interest to those planning to use GPS in their location system. A report (SAND93-0827 – Global Positioning Systems Receiver Evaluation Results by Raymond H. Byrne) has "Unlimited Release" classification and is available from Sandia.

Metal Detector Evaluation

Sandia has tested various metal detecting devices, which were demonstrated to us. The main application of such devices is in airports, courtrooms and other similar environments where security is a concern.

While the original devices were designed to detect conventional (i.e., iron based) weapons, the equipment today must also detect weapons made of more exotic (for example plastic) materials. This means that while the original detectors measured magnetic changes (essentially using an inductive loop) the current detectors look for other features, (i.e., changes in capacitance).

We were given a demonstration of various object detection systems and discussed the engineering aspects involved. While it was generally agreed that such devices have only limited use in transit, a couple of transportation related applications appear possible.

Automatic driving was one application that was specifically discussed whereby a vehicle would automatically follow existing traffic lines which are painted on the road. The only modification to the existing line would be to add metal filings to the paint. Since most traffic lines are typically painted on a yearly basis, the added cost would be minimal. This application has the advantage of not requiring a live loop or mechanical device (e.g., side wheels on a bus which would use the curb for guidance) and consequently could be inexpensive to implement.

The proposed application could be used to guide a bus on a dedicated right of way or to guide a line painting truck. In the future, such a system could also be used to guide drivers on an ordinary roadway.

As such methods do not require either mechanical or visual contact, another application may be in snowplowing where the road surface (and often the road itself) is not necessarily visible.

Demonstration of Robotics Activities

As mentioned before, Sandia is not only contributing to the design of nuclear weapons, but also develops systems and methods for their safe disassembly and disposal.

Until recently many of these functions were done manually and workers could work only for a limited time in order not to exceed the safe exposure times. In order to improve the situation, robotic systems are now being developed for these purposes.

Disassembly of nuclear weapons presents unique logistic and technical problems. In addition to radiation hazards (which not only affects human workers but also may affect materials), there is also a possibility of explosion as the plutonium "pit" is surrounded by a conventional explosive, which acts as a detonator. Consequently, all tooling has to be electrically isolated providing protection not only against stray currents but also against those induced by lightning strikes, etc.

The batches are small and hence frequent reprogramming is necessary. Additionally, there may be variations between weapon models or the position of parts further increasing the difficulty of the task.

In order to make these tasks economical or even technically feasible, the robotic group has developed intelligent software, which not only simplifies programming, but also adapts itself to different environments which is detected by sensors.

It should be noted that the software works with a variety of sensors including the usual ones like vision, and also with more exotic versions such as force sensor.

Such developments have tremendous applications in civilian life, including manufacturing and maintenance tasks where in real life, products (even those originally of the same model and series etc.) have been modified over its working life.

A practical example may be a system to wash subway cars (contemplated recently by a number of transit agencies) or a device for automatic cleaning of bridges, where typically the "regular" structure is often modified by additional downspouts, electrical

cables, etc. Another example may be automatic fuelling of vehicles, which the lab demonstrated recently using one of their mobile robots.

We have also witnessed an interesting demonstration of virtual reality computing. Such techniques can be used to greatly improve such functions as mechanic or driver training.

Electromagnetic Interference Test Facility

Sandia's electromagnetic interference test facility is the most sophisticated in the world. It permits testing of both small equipment and also of large scale complete objects like cruise missiles and aircraft.

The purpose of the facility is to ensure that various systems and weapons will function correctly in the presence of electromagnetic interference from electrostatic discharges created by a human body, lightening, or even a nuclear blast.

The main facilities are listed as follows:

- lightning simulation facility;
- electromagnetic interference and electromagnetic compatibility test facility;
- cable test facility;
- electromagnetic environments simulator
 - fifth-scale electromagnetic environment simulator
 - electromagnetic radiation testing
 - electromagnetic pulse testing;
- direct-drive facility
- microwave test facility
 - continuous-wave testing
 - pulse testing;
- an anechoic chamber test facility.

All the equipment is fully automated and is supported by analysis capabilities.

It should be noted that electromagnetic interference is relatively poorly understood and is often blamed for electrical equipment failure. Thus, transfer of Sandia's knowledge to civilian equipment can improve the reliability of such equipment. This may also be very important in advanced transportation projects where electric drive and electronic controls have been contemplated. One such project may be the Advanced Technology Transit Bus (ATTB) project . It should be noted that Sandia can test various small components as well as a full size bus.

Lightweight Materials Activities

Sandia conducts extensive research into the development of new materials. Some of these materials can be used in other applications in addition to military and nuclear applications.

Sandia conducts research in both materials and processing. The materials include metals, ceramics/glasses and polymers while processing research addresses such techniques as foaming, welding, molding, soldering, and ceramic/metal sealing.

For example, Sandia has a considerable expertise in diamond coating technology and is presently conducting a joint research project with Du Pont that is worth \$6 million over a three-year period with both sides sharing the funding equally. Besides being the world's hardest substance, diamond is also an excellent thermal conductor (e.g., a diamond has five times the thermal conductivity of copper, at room temperature). The high thermal conductivity of a diamond could be used to disperse heat very quickly – hence diamond coated chips can permit much denser packaging of electronic components.

Another application may be to increase the strength of a material, or to make it scratch proof by depositing a thin layer of diamonds on its surface. Such an approach has already been used to produce scratch proof sunglass lenses and can perhaps be applied to produce a scratch proof windshield, although the cost may be excessive. Another application may use a diamond layer for windshield defrosting which would heat the entire surface.

The research effort in this area is now directed toward making the layer deposition at a much lower temperature (to be able to coat plastic substrates) and to reduce costs.

Another area discussed with Sandia was the development of graffiti resistant materials.

Fire/crash Modelling and Testing

Sandia performs extensive research into crash worthiness of their vehicles. The work includes both modelling and actual crash testing of various vehicles.

The effort deals with both structural strength and combustion. Extensive theoretical work done at Sandia in these areas along with their modelling facilities once again appears to be second to none. For example, their finite element models are extremely detailed (over 500,000 equations) to permit modelling of such complex matters as severe buckling of composite materials or detail modelling of various combustion situations.

Their core technologies include:

- fire physics
- heat transfer physics
- deformation physics
- structural response to thermal and blast loads
- computational fluid mechanics
- experimental and test facilities

Such expertise could be applied to several areas in transit. For example, new vehicle construction uses more and more composite parts and eventually transit vehicle structures may be made totally of composites (e.g., Neoplan or ATTB project). Little is now commercially known about crashworthiness and even less is known about long term behaviour (i.e., fatigue) of such structures, a subject vital to the transit industry where the vehicle may be required to last up to 30 years (eg., subway cars).

Another area where Sandia could contribute considerable expertise is in the area of alternate fuel applications. Although a great deal of knowledge is available about diesel-powered vehicles, limited work has been in the field of alternate fuel combustion processes, particularly in crash situations. These subjects are becoming more and more important and eventually will have to be addressed.

Slow-Scan CCTV Project

Many military installations are susceptible to false alarms; for example, the triggering of a sensor in a remote location by weather conditions or animal intrusion. In order to eliminate the need to continuously monitor a video camera or to avoid sending a person to investigate, an inexpensive CCTV camera system was developed to transmit a "near live" picture.

Such a system uses a simple, commercially available camera and a specially developed imaging board valued at about \$200. The camera is equipped with an inexpensive 9600 baud modem to transmit the data, via radio or telephone lines. The camera remains idle until triggered by an intrusion sensor. Once triggered, the camera takes a picture, waits one second, and takes a second picture.

While the first picture is being transmitted to a PC located at a central monitoring station (typically up to 40 seconds), the imaging board computes the difference between the two pictures and then sends this data (typically less than 10 seconds). By switching between the two images, the operator is able to determine what object triggered the alarm.

Such a system can be installed in various locations in transit applications including vehicles without requiring a fixed wire.

Smart Card and Biometric Identifiers

Sandia has tested and demonstrated to us a range of commercially available security systems which use biometric identifiers to confirm a person's identity and to permit or deny access.

The systems demonstrated were all PC based and reasonably priced. The following identifiers were used to identify a person:

- palm print
- thumb print
- retina scan
- voice print.

Every system has to be "taught" first (i.e., the potential user has to record his "print") in order to recognize a person later, which takes a few minutes. The information is stored and a search is made whenever a person tries to gain entry to a secure area. If a match is found, admittance is gained. Otherwise, admittance is denied and a report filed.

It should be noted that the systems tested were not quite fool-proof, with voice scan systems faring most poorly.

The lab in question also deals with "smart badge" matters. These are, in effect, smart cards which can be used as passes to permit or deny access to the facilities. It should be noted here that the Department of Energy works on a "standard" smart badge to be used throughout their various facilities. A portion of their work (e.g., encryption techniques) may be applicable to new fare cards being proposed.

Conclusion

Sandia Labs are at the leading edge of a wide variety of technologies, and can offer the transit/transportation industry many solutions to practical problems.

APPENDIX E

TRANSIT DEVELOPMENT CORPORATION, INC. I-TIME PROGRAM

FIELD TRIP REPORT

Windsor Industries, Inc.
1351 W. Stanford Ave.
Englewood, Colorado 80110
(303) 762-1800

Following the I-TIME Task Force Meeting in Denver, Jeffrey Mora, FTA liaison, and John Schiavone, TDC staff, traveled to Windsor Industries' facility in Englewood Colorado, on September 14, 1993. Windsor manufactures 50 different floor and carpet cleaning machines. Of particular interest to the Task Force was their RoboScrub Robotic Floor Scrubber. With up to five hours of run time, the robotic scrubber can clean 80,000 square feet of flooring on a single electrical charge.

RoboScrub uses a single on-board computer to control its navigation and object avoidance systems. To navigate, it transmits an invisible light beam to wall-mounted bar codes, which it uses as targets. Navigation information is captured and decoded, allowing the robot to calculate its position. RoboScrub has a 360° field of vision, and can read targets up to 600 feet away. Using the targets as a reference, the robot is programmed to clean a defined area. It begins at the starting point of a defined area and continues its cleaning operation until reaching the finishing point. The robot can also move from one cleaning location to another without operator assistance.

To avoid objects in its path, 23 sensors are placed around the scrubber's perimeter. Once it detects an object, the robot stops, plots a course around, and then resumes its preprogrammed cleaning schedule.

Conducting the demonstration at Windsor were Robert O'Hara, Director of Robotic Products, and Edward Biegel, Project Engineer. A RoboScrub robot, preprogrammed to clean a small area within the Windsor facility, moved in a straight line once the "auto" button was pressed on the control panel. After reaching the end, it turned 180° to clean the area adjacent to its first path. When stepping in front of it, the robot stopped cleaning and moved around us before beginning again.

Roboscrub is being used at several locations worldwide including a US Post Office, a NASA space-shuttle facility and the Amsterdam Airport. The per-unit cost ranges between \$55,000 and \$65,000.

Report Prepared By:
John J. Schiavone
October 4, 1993

