



U.S. Department  
of Transportation  
**Research and  
Special Programs  
Administration**

# **Operator Performance Measurement: Developing Commonality Across Transportation Modes - Proceedings of a September 1994 Workshop**

DOT Human Factors Coordinating Committee

Final Report  
November 1996

---

---

U.S. Department of Transportation  
Research and Special Programs Administration  
John A. Volpe National Transportation Systems Center  
Cambridge, MA 02142-1093

Prepared for the  
Office of Research Policy and Technology Transfer  
Research and Special Programs Administration  
U.S. Department of Transportation  
Washington, D.C. 20590

TL  
152.3  
.H84  
1996

### **NOTICE**

This document is disseminated under the sponsorship of the Department of Transportation in the interest of information exchange. The United States Government assumes no liability for its contents or use thereof.

# REPORT DOCUMENTATION PAGE

Form Approved  
OMB No. 0704-0188

Public reporting burden for this collection of information is estimated to average 1 hour per response, including the time for reviewing instructions, searching existing data sources, gathering and maintaining the data needed, and completing and reviewing the collection of information. Send comments regarding this burden estimate or any other aspect of this collection of information, including suggestions for reducing this burden, to Washington Headquarters Services, Directorate for Information Operations and Reports, 1215 Jefferson Davis Highway, Suite 1204, Arlington, VA 22202-4302, and to the Office of Management and Budget, Paperwork Reduction Project (0704-0188), Washington, DC 20503.

1. AGENCY USE ONLY (Leave blank)

2. REPORT DATE  
November 1996

3. REPORT TYPE AND DATES COVERED  
September 1994 - December 1994

4. TITLE AND SUBTITLE  
Operator Performance Measurement: Developing Commonality  
Across Transportation Modes - Proceedings of a September 1994  
Workshop

5. FUNDING NUMBERS  
  
OP504/T5027

6. AUTHOR(S)  
DOT Human Factors Coordinating Committee, Beverly Messick  
Huey\*, Mary D. Stearns

7. PERFORMING ORGANIZATION NAME(S) AND ADDRESS(ES)  
U.S. Department of Transportation  
Research and Special Programs Administration  
John A. Volpe National Transportation Systems Center  
Cambridge, MA 02142

8. PERFORMING ORGANIZATION  
REPORT NUMBER  
  
DOT-VNTSC-RSPA-95-2

9. SPONSORING/MONITORING AGENCY NAME(S) AND ADDRESS(ES)  
U.S. Department of Transportation  
Research and Special Programs Administration\*\*  
400 7th Street, S.W.  
Washington, DC 20590

10. SPONSORING/MONITORING  
AGENCY REPORT NUMBER  
  
DOT-VNTSC-RSPA-95-2

11. SUPPLEMENTARY NOTES  
\*under contract to:  
U.S. Department of Transportation  
Research and Special Programs Administration  
John A. Volpe National Transportation Systems Center  
Cambridge, MA 02142

\*\*in collaboration with:  
FAA, FHWA, FRA, FTA, MARAD, NHTSA, OST/P, USCG

12a. DISTRIBUTION/AVAILABILITY STATEMENT  
This document is available to the public through the National Technical Information  
Service, Springfield, VA 22161

12b. DISTRIBUTION CODE

13. ABSTRACT (Maximum 200 words)

This report describes the proceedings of the Workshop on Human Factors Research held in Reston, Virginia. The objectives of the workshop were to: foster an interchange of experience in measuring and analyzing operator performance data; encourage commonality in operator performance and measurement and analysis; identify opportunities for cross-modal research and analysis on performance; and recommend directions for joint research on operator performance.

14. SUBJECT TERMS  
Multi-modal, Cross-modal, Commonality, Human Factors,  
Measurement, Intermodal, Performance

15. NUMBER OF PAGES  
92

16. PRICE CODE

17. SECURITY CLASSIFICATION  
OF REPORT  
Unclassified

18. SECURITY CLASSIFICATION  
OF THIS PAGE  
Unclassified

19. SECURITY CLASSIFICATION  
OF ABSTRACT  
Unclassified

20. LIMITATION OF ABSTRACT



## PREFACE

This report describes the proceedings of the Workshop on Human Factors Research in Reston, Virginia on September 20-21, 1994. The objectives of the workshop were to: foster an interchange of experience in measuring and analyzing operator performance data; encourage commonality in operator performance measurement and analysis; identify opportunities for cross-modal research and analysis on operator performance; and recommend directions for joint research on operator performance.

The work was sponsored by the Department of Transportation (DOT) Human Factors Coordinating Committee which represents the National Highway Safety Administration (NHTSA), Federal Aviation Administration (FAA), Federal Highway Administration (FHWA), Federal Railroad Administration (FRA), Federal Transit Administration (FTA), Maritime Administration (MARAD), U.S. Coast Guard (USCG), and Research and Special Programs Administration (RSPA). The work was performed by Beverly Messick Huey and Mary D. Stearns.



# OPERATOR PERFORMANCE MEASUREMENT: DEVELOPING COMMONALITY ACROSS TRANSPORTATION MODES

Summary of a Human Factors Workshop,  
September 20-21, 1994

## TABLE OF CONTENTS

|     |                                                                                                           |    |
|-----|-----------------------------------------------------------------------------------------------------------|----|
| I.  | Workshop Overview                                                                                         | 1  |
|     | Background of the DOT Human Factors Coordinating Committee                                                | 3  |
|     | Purpose of this Human Factors Workshop                                                                    | 3  |
|     | Focus of this Human Factors Workshop                                                                      | 3  |
|     | Organization of this Human Factors Workshop                                                               | 4  |
|     | Recommended Future Directions for Human Factors Research Within the<br>Department of Transportation (DOT) | 6  |
| II. | Workshop Materials                                                                                        | 7  |
|     | Welcome                                                                                                   | 9  |
|     | <i>Robert Clarke, Chair, DOT Human Factors Coordinating Committee</i>                                     |    |
|     | Address--                                                                                                 | 11 |
|     | <i>John N. Lieber, Deputy Assistant Secretary for Transportation Policy</i>                               |    |
|     | Address--A Coordinated Vision for Transportation R&D                                                      | 12 |
|     | <i>George Parker, Associate Administrator for R&amp;D, NHTSA (On Behalf of Noah<br/>        Rifkin)</i>   |    |
|     | Paper Presentations                                                                                       |    |
|     | Approaches to Measuring Operator Performance Across Transportation Modes                                  | 18 |
|     | <i>R. Wade Allen, Systems Technology, Inc.</i>                                                            |    |
|     | Interpretation of Operator Performance Data                                                               | 43 |
|     | <i>Alison Smiley, PH.D., Human Factors North, Inc.</i>                                                    |    |

25501

TL  
152.3  
.H84  
1996

FEB 25 1997

TABLE OF CONTENTS (CONT.)

Workshop Organization

|                                                    |    |
|----------------------------------------------------|----|
| Agenda                                             | 69 |
| Members - DOT Human Factors Coordinating Committee | 72 |
| List of Attendees                                  | 75 |
| Profiles of Paper Presenters                       | 80 |



## LIST OF FIGURES

| <u>Figure</u> |                                                                                                       | <u>Page</u> |
|---------------|-------------------------------------------------------------------------------------------------------|-------------|
| 1.            | Generic Transportation System and Human/Machine Interfaces                                            | 19          |
| 2.            | Intersection of Human, Vehicle, Systems and Operations Considerations in a Transportation System      | 19          |
| 3.            | Generic Dynamic Block Diagram for a Transportation System                                             | 21          |
| 4.            | Input/Output Relationships Between Human Behavioral Components                                        | 22          |
| 5.            | Human/Machine Dynamic Response Measurements                                                           | 29          |
| 6.            | Traffic Safety Interpretation for the Standard Deviation of Lateral Lane Position (SDLP)              | 30          |
| 7.            | Effect of Roadmarking Contrast on SDLP                                                                | 31          |
| 8.            | Air Carrier Accidents Distributed by Phase of Flight, 1959-1983: World Wide Jet Fleet, All Operations | 32          |
| 9.            | Crew Interaction with Aircraft and Automated Systems, Ground System and Air Traffic Control           | 32          |
| 10.           | Distribution of Scenario Slide Number at Which Each Pilot Aborted                                     | 34          |
| 11.           | Distribution of Accumulated Rating Response Times Up to Abort Decision                                | 34          |
| 12.           | Landing Approach/Takeoff Decision Tree                                                                | 35          |

## LIST OF TABLES

| <u>Table</u> |                                                | <u>Page</u> |
|--------------|------------------------------------------------|-------------|
| 1.           | Transportation System Operational Conditions   | 23          |
| 2.           | Situation Awareness (Windshear Hazard) Ratings | 33          |
| 3.           | Operator Characteristics                       | 44          |
| 4.           | Task Characteristics                           | 45          |



**PART I.**

**WORKSHOP OVERVIEW**



## **Background of the DOT Human Factors Coordinating Committee**

In 1991 the DOT established a department-wide Human Factors Coordinating Committee composed of appointed representatives from each of the modal administrations, i.e., National Highway Traffic Safety Administration (NHTSA), Federal Highway Administration (FHWA), Federal Railroad Administration (FRA), Federal Aviation Administration (FAA), Federal Transit Administration (FTA), Maritime Administration (MARAD), United States Coast Guard (USCG), and the Research and Special Programs Administration (RSPA). The mission of the Human Factors Coordinating Committee was to develop multi-modal coordination and synergy, to be a departmental resource for consultation and information exchange, and identify and jointly sponsor multi-modal mutually beneficial projects. This committee, which initially focused on information exchange, supports jointly-funded coordinated research activities and also supports the development of an integrated DOT focus on human factors research.

This committee also serves as a departmental resource to the Office of Science and Technology Policy (OSTP). Recently, the committee's role has expanded to include strategic planning activities as well as to address the technical issues the committee had originally been tasked to undertake. The President's National Science and Technology Council has provided the impetus to begin strategic planning on human performance and behavioral science in transportation within the DOT and Executive Branch agencies including DOD, NASA and NSF.

## **Purpose of this Human Factors Workshop**

The DOT modal administrations' human factors research on operator performance typically has been dedicated to modal needs. The intent of the DOT Human Factors Coordinating Committee is to enhance coordination between modal human factors R&D programs. To address this, the DOT Human Factors Coordinating Committee sponsored this invitational workshop to explore ways to encourage commonality so that operator performance data can be useful across modes.

The DOT Human Factors Coordinating Committee hopes the workshop results will enhance information exchange and identify areas in which jointly sponsored multi-modal research efforts may be undertaken. The committee anticipates that this summary of the workshop results will help to identify cross-modal research and analysis opportunities, encourage commonality in standards, exchange of experience, and recommend directions for future cross-modal research.

## **Focus of this Human Factors Workshop**

The DOT Human Factors Coordinating Committee agreed to hold this workshop to consider, in particular, whether and how it might be possible to foster commonality in operator performance measurement across transportation modes. The committee selected the workshop topic -- transportation operator performance measurement methodologies, performance metrics, and data analysis -- in part, because there is some common work being done on this topic.

Human performance research in transportation classifies operators in three ways: as operators/controllers, crew members, and maintenance workers. Operators include trained professionals and commercial operators (including aircraft pilots, locomotive engineers/rail transit operators, ship helmsman/watch officers, truck drivers, bus drivers, rail operators, air traffic controllers, and vessel traffic service watchstanders) to private citizens. Crew members (including flight attendants, railroad brakemen/conductors, and shipboard crews) have role(s) affecting the functioning and safety of the vehicle or system. Maintenance workers (such as highway repair crews, aircraft mechanics, rail maintenance-of-way and signals/communications workers, and truck/bus mechanics) keep equipment operational. They may not be in direct control of the operation, but their roles in keeping the vehicles and other related equipment functioning smoothly and efficiently is critical.

Within the DOT, human factors research has tended to focus on behaviors; equipment interfaces; equipment design and performance; operational procedures and scheduling; medical qualifications; training, selection, licensing, and certification; and individual performance capabilities and limitations. When dealing with cross modal systems, however, the range of capabilities and systems, as well as the level of control that is exhibited over them, varies greatly. Potential categorizations for cross modal human factors research include the following: (1) type of operator (paid professional vs. private individual); (2) amount of training (highly skilled/trained vs. minimal skills/no training); and (3) type of environment (controlled environment vs. open environment). There is more opportunity for control and/or intervention when the focus is on professional or commercial operators, rather than private individuals. For example, the FAA has more regulatory authority over commercial pilots and operations than they do with general aviation. Commercial ship operations differ from pleasure boat operations. Similarly, commercial vehicle operators, (e.g., truck and bus) operate with different constraints than private automobile operators. However, the modes share many common issues including fatigue, fitness/readiness for duty, work/rest scheduling, drug/alcohol effects, automation, aging, equipment and display interfaces, anthropometrics, and emergency egress.

### **Organization of this Human Factors Workshop**

The people invited to participate in this workshop included members of DOT modal administrations concerned with human performance issues, representatives from other federal agencies who have ongoing involvement with human factors issues related to transportation, and selected experts in human factors and transportation from outside government.

Robert Clarke, Chair of the DOT Human Factors Coordinating Committee, opened the workshop and introduced the committee members. John N. Lieber, Deputy Assistant Secretary for Transportation Policy, welcomed the workshop participants on behalf of the DOT. George Parker, Associate Administrator for R&D at NHTSA, speaking on behalf of Noah Rifkin, Director of Technology Deployment, Office of the Secretary, presented "A Coordinated Vision for Transportation R&D." This address described Secretary Peña's and the DOT's initiatives in

transportation R&D strategic planning and the specific implications of these initiatives for human factors activities.

During this workshop there was discussion of the issues identified in the invited papers and the reports from each breakout session helped to define a research agenda which will foster collection of operator performance measurement data with maximum cross-modal utility. The two invited papers and ensuing breakout sessions focused on what was common in human performance measurement methodologies, performance metrics and indices, and data analysis and interpretation techniques.

This summary document contains the invited papers, summarizes the findings of the workshop participants, and defines a ground-breaking agenda of state-of-the-art research topics to foster measurement of operator performance useful across modes.

Two commissioned papers were presented at this workshop. R. Wade Allen, Systems Technology, Inc., presented a paper entitled, "Approaches to Measuring Operator Performance Across Transportation Modes." Alison Smiley, Human Factors North, presented a paper entitled, "Interpretation of Operator Performance Data." Workshop participants had the opportunity to discuss both presentations in plenary and small group sessions.

R. Wade Allen described approaches to measuring operator performance across transportation modes. He considered both the human and the system element and identified issues common across modes (e.g., workload, human sensory elements) as well as mode specific (e.g., situation awareness). He concluded his presentation by identifying transportation challenges to consider during the break-out sessions.

The second presentation, by Alison Smiley, addressed how to interpret operator performance data and the possibility of making generalizations across transportation modes, given the differences in operators, tasks, and operational characteristics across modes. She reviewed the cross-modal use of performance data, including the generalizability of performance data and experimental findings, operational guidelines, and design decisions. Dr. Smiley concluded that cross-modal generalization should be done cautiously due to modal differences which limit the generalizability of data from one mode to another.

The breakout sessions following the two talks addressed:

- (1) modeling operator performance,
- (2) operator performance data reduction/analysis: common concerns, common strategies,
- (3) data/measurement equipment: is commonality possible,
- (4) task-specific studies: how they can be made useful across modes,

- (5) statistically significant versus meaningful results: how "big" a difference has to be before it matters,
- (6) the possibility of uniform interpretation of data,
- (7) interpreting results: how generalizable they should be,
- (8) impact of differences in subject populations on the cross-modal usefulness of data,
- (9) controlled versus in-situ testing: when is one more appropriate than another.

The breakout groups following each of the two invited talks discussed the issues arising from the presentation. One member of the coordinating committee served as a facilitator and group discussion leader for each breakout session. In these sessions they assessed the state of the art for a particular topic, discussed how to advance cross-modal coordination, identified problems in cross-modal coordination, and made recommendations. Session participants were instructed to arrive at some consensus about the potential cross-modal coordination for each breakout issue. At the conclusion of the workshop, the discussion leaders presented the results of their respective breakout sessions. Robert Clarke concluded the workshop with an overview of the issues addressed and the future directions for human factors research within the DOT.

### **Recommended Future Directions for Human Factors Research Within the Department of Transportation (DOT)**

The recommendations from the breakout groups on future direction for human factors research on specific operator performance measurement within DOT are as follows:

- The DOT Human Factors Coordinating Committee should continue to pull together ongoing human factors activities within DOT.
- DOT should surmount modal concerns, coordinate human factors research efforts, and aggregate work in transportation, human factors, human performance, and behavioral science R&D into a strategic plan.
- DOT, through coordination with the Department of Defense (DOD) and the National Aeronautics and Space Administration (NASA), can and should leverage its human factors resources.
- The DOT Human Factors Coordinating Committee should sponsor "mini technical conferences" to address human factors related topics of common modal concern.



**PART II.**  
**WORKSHOP MATERIALS**



## Welcome

*--Robert Clarke, Chair, DOT Human Factors Coordinating Committee*

Robert Clarke welcomed the workshop participants and then introduced the members of the Department of Transportation (DOT) Human Factors Coordinating Committee (see Appendix A) which represents the National Highway Traffic Safety Administration (NHTSA), Federal Highway Administration (FHWA), Federal Railroad Administration (FRA), Federal Aviation Administration (FAA), Federal Transit Administration (FTA), Maritime Administration (MARAD), U.S. Coast Guard (USCG), Office of Science and Technology (OST/P), and Research and Special Programs Administration (RSPA). The Human Factors Coordinating Committee is an outgrowth of a previous administration's National Transportation Plan, the development process for which began in March 1991. The members of this committee, which first came together under the auspices of Clay Foushee, former Senior Advisor for Human Factors at the FAA and have met approximately three times per year, have focused on technical issues in an attempt to identify areas of common interest and potential collaborative efforts.

The objectives of the committee are to (1) develop multi-modal coordination and synergy, (2) be a departmental resource for consultation and information exchange, and (3) identify and jointly sponsor multi-modal mutually beneficial projects. For the near-term, the committee has focused on information exchange and has explored the possibility of establishing jointly funded coordinated research activities. The initial focus--on transportation operator performance measurement methodologies, performance metrics, and data analysis and presentation--is being addressed in this workshop. This topic was chosen, in part, because there is already much common work being done.

A longer-term activity is the development of a DOT National Plan for Human Factors Research. The committee is a departmental resource to the Office of Science and Technology (OST) for information exchange; however, that role has been expanding to include more administrative and strategic planning activities and away from the purely technical issues the committee had been addressing originally. Recently, the President's National Science and Technology Council has provided an impetus to begin strategic planning on behavioral and human factors research within the DOT and beyond that within the Executive Branch.

In transportation three groups of individuals are of concern: transportation operators/controllers, crew members, and maintenance workers. Most of the concerns deal primarily with operators, who range from trained professionals and commercial operators (including aircraft pilots, locomotive engineers/rail transit operators, ship helmsman/watch officers, truck, drivers, rail CTC operators, air traffic controllers, and vessel traffic service watchstanders) to private citizens. When dealing with multi-modal systems, however, the range of capabilities, the range of systems, and the level of control that is exhibited over them varies greatly, which limits the multi-modal coordination that occurs.

For crew members (including flight attendants, railroad brakemen/conductors, and shipboard crews), there is a concern about the role(s) they play in the functioning and safety of the vehicle or system. Finally, maintenance workers (including highway repair crews, aircraft mechanics, rail maintenance-of-way and signals/communications workers, and truck/bus mechanics) play a large role in keeping equipment operational. They may not be in direct control of the operation, but their roles in keeping the vehicles functioning smoothly and efficiently are critical.

Within the Department of Transportation, human factors issues focus on behavior; equipment interfaces; equipment design and performance; operational procedures and scheduling; medical qualifications; training, selection, licensing, and certification; and individual performance capabilities and limitations.

There are a variety of other considerations when addressing multi-modal human factors issues, which include the following: (1) type of operator (paid professional vs. private individual); (2) amount of training (highly skilled/trained vs. minimal skills/no training); and (3) type of environment (controlled environment vs. open environment). When one is dealing with paid professionals or commercial operators, rather than private individuals, there is more opportunity for control and/or intervention. For example, the FAA has a much easier time dealing with commercial pilots and commercial operations than they do with light civil aircraft. Likewise, in ship operations, commercial ships are different than pleasure boat operators. In the highway environment, commercial truck and bus operators have different sets and classes of constraints as compared to private automobile operators.

There are a number of common issues that are shared among the modes: fatigue, fitness/readiness for duty; work/rest scheduling, drug/alcohol effects, automation, aging, equipment and display interfaces, anthropometrics, and emergency egress. These, as well as additional, common issues will be discussed in more detail in the breakout sessions.

## **Address**

*--John N. Lieber, Deputy Assistant Secretary for Transportation Policy*

As a New Yorker who arrived here a couple of months ago and is doing serious driving for the first time, I am acutely aware of the problem of operator performance. Just before you continue the serious work of this process, I wanted to deliver Secretary Peña's best wishes for the success of this effort. As you know, he has made safety one of the goals of his strategic plan. He has given this enormous emphasis in his entire program. With the confirmation of Dr. Ricardo Martinez as the NHTSA Administrator, I think you have a very, very effective advocate for safety issues leading the charge, and this is going to continue to be a focus point of this administration's entire transportation program.

The public, as all of you are aware, has, I think, higher and higher expectations with respect to safety and the government's ability to provide for it in its transportation programs. For better or worse, media trends give more and more attention to accidents and safety issues, in general, requiring us to rationalize and explain what we are doing and make what you are doing very, very important.

I also want to congratulate this group that began the workshop sometime ago. It is a model for the concepts of reinventing government that the Vice President has talked about and brought to the forefront. It brings into realization the concept of intermodal cooperation, and it also is a model for staff level initiatives. I know that this was a product of, in some ways, another administration's efforts and because of the staffs and the sense that this was very important and worthwhile, it continued through change in political administrations and that really is something to be congratulated. So, continued success in this effort, and thank you all for attending and giving this your energy and your effort.

## **Address--A Coordinated Vision for Transportation R&D\***

*--George Parker, Associate Administrator for R&D, NHTSA*

*(On Behalf of Noah Rifkin)*

I'm talking to you today about the Department's vision for transportation R&D; I want to focus on the major changes taking place within the Department and across the Federal Government. First, there is a new emphasis on technology research and development. The Clinton Administration, and Secretary Peña, in particular, are committed to bringing about the kinds of technological advances that will ensure U.S. competitiveness and growth in a global economy.

Second, there is growing recognition within the Department of the importance of research addressing human factors in transportation. For instance, human error is widely believed to be the principal cause of most transportation accidents, with estimates ranging from 60 to 90 percent. Human errors are a leading cause of transportation-related deaths, injuries, and property losses. That is why the Department of Transportation, among the Federal Government's civilian agencies, has the most compelling need for research and development in human factors. And that is why DOT will take the lead in identifying priority human factors research needs in transportation and will work to ensure coordination among our modal administration's R&D programs.

### **The Clinton Technology Policy**

The Clinton Administration has a new outlook toward technology. In fact, technology research and development is the centerpiece of the President's strategy for U.S. economic growth and investment in the future. As stated in the President's technology policy, investing in technology is investing in America's future. American technology must move in a new direction to spur economic growth, create good jobs, and, most of all, improve the lives of Americans.

In the past, the Federal Government's role in technology development has been limited to support basic science and mission-oriented research in the Defense Department, NASA, and other agencies. Although this strategy was appropriate for a previous generation, it is not enough for today's challenges. These challenges demand that we refocus our technology efforts to achieve the following goals:

- A healthy, educated citizenry
- Job creation and economic growth
- World leadership in basic science, mathematics, and engineering
- Improved environmental quality
- An enhanced information infrastructure.

Transportation is a critical component of the Administration's new direction in technology policy. As noted in the Administration's policy, "a competitive, growing economy requires a

\*This address was delivered in September 1994, and is an accurate description of DOT's research policy and science and technology coordination activities at that time. However, substantial advances have been made since it was delivered, especially in the context of DOT's work through the National Science and Technology Council's Transportation R&D Committee. Further information on DOT's current activities and links related to sites such as that of the National Science and Technology Council are available through the U.S. Department of Transportation's INTERNET Home Page at <http://www.dot.gov>.

efficiently....Technologies that increase the speed, reliability, and cost-effectiveness of the transportation sector also will increase the economy's competitiveness and ability to create jobs."

### **DOT's Commitment to Technology Development**

With the full support of President Clinton, Secretary Peña is committed to leading an effort to realize a vision of sustainable, seamless, and global transportation. Support for technology research and development is one of Secretary Peña's top priorities. As stated by the Secretary:

"DOT has begun a new era. We will play an important role with our customers and industry to support R&D activities. We will provide not only strategic investments but leadership in steering Government R&D work."

Secretary Federico Peña  
U.S. Department of Transportation  
before the Transportation Research Board  
January 12, 1994

One very important example is the Technology Reinvestment Project, or TRP, led by the Defense Department's Advanced Research Projects Agency. The Department of Transportation is a full partner in the TRP, an effort to stimulate the transfer of military technologies to competitive, commercial products that will boost U.S. productivity. The final awards for the 1993 TRP were announced in March, and research that supported transportation technology was a major focus of the winning proposals. Twenty-seven proposals with a total face value of \$420 million were directly related to transportation. Other winning proposals in areas such as the environment and telecommunications will also benefit the transportation sector.

DOT has also been working with the Department of Commerce and the National Institute of Standards and Technology to include transportation as a focus area of the Advanced Technology Program. And the Department is a key player in the Partnership for a New Generation of Vehicles, or PNGV. In September 1993, President Clinton, Vice President Gore, and the CEOs of Chrysler, Ford, and GM announced a historic new partnership aimed at strengthening U.S. competitiveness and protecting the environment. DOT's primary role in the PNGV, through its National Highway Traffic Safety Administration, will be to work with engineers and designers to achieve crashworthiness, crash avoidance, and other safety characteristics to be met by all new vehicles sold in the U.S.

These and other programs provide a unique opportunity for DOT to steer federal funding toward the development of technologies that will enable new transportation-related products and processes. To ensure that technology research and development is a priority, Secretary Peña has made organizational changes within the Department:

- Technology development is new one of the Department's seven core goals, as recently stated in our Strategic Plan.
- DOT's total budget authority for R&D has risen from \$559 million in FY 1992, to \$587 million in 1993 and \$605 million in 1994--in times of decreasing resources. The Department's budget request for FY 1995 is \$692 million.
- Structural changes have been made as well. The position Noah Rifkin holds, Director of Technology Deployment, was created specifically for improving and coordinating the Department's R&D initiatives. The Secretary wanted to elevate a lead responsibility for DOT R&D to someone on his immediate staff.

As well as turning inward, we have turned outward. The Secretary was asked by the President's Science Advisor, John Gibbons, to take the lead in establishing an Interagency Coordinating Committee on Transportation R&D. One of the President's major priorities is to foster a consistent R&D policy across the Government. To prepare coordinated and balanced R&D strategies and budget guidance, the President established the National Science and Technology Council, the NSTC, a joint undertaking of the Office of Management and Budget and the White House Office of Science and Technology Policy. In turn, the NSTC created nine interagency coordinating committees:

- Committee on Health, Safety, and Food R&D
- Committee on Information & Communication R&D
- Committee on National Security R&D
- Committee on Education & Training R&D
- Committee on Fundamental Science
- Committee on International Science, Engineering, & Technology R&D
- Committee on Environment & Natural Resources Research
- Committee on Civilian Industrial Technology
- Committee on Transportation R&D.

The Committee on Transportation R&D provides and supports:

- Wise and effective tactical and strategic decisions and policies
- The best possible performance of transportation infrastructure
- Improvement of overall performance characteristics of all types of vehicles
- Expansion of transportation alternatives
- Reestablishment of the U.S. as international leader in transportation technology.



The Transportation Committee completed its initial report in April, which contains strategic budget guidance for improving transportation research and development. The Committee's report identified a number of research areas that are top priorities for transportation R&D, as well as gaps in our current R&D efforts:

- System assessment and analysis--e.g., environmental measurement capabilities, human performance
- Physical infrastructure--e.g., IVHS, high-performance materials
- Information infrastructure--e.g., GPS, tracking of cargo/vehicles, air traffic control technology
- Vehicles--e.g., advanced aircraft technologies, private motor vehicles, ship construction, next-generation launch vehicles.

Within the Transportation Committee, one of the most active groups is the subcommittee on behavioral science and human factors R&D, an outgrowth of the Department's Human Factors Coordinating Committee. This subcommittee deals with people acting as operators, crew, or customers--an integral part of all facets of transportation. The subcommittee has identified a number of human factors research areas shared by most or all of DOT's modal administrations. Examples of areas of common interest and the DOT modal administrations that have active research programs in these areas include:

- Fatigue/Workload/Hours of service  
(FAA, FRA, NHTSA, OMCS, CG, MARAD)
- Automation  
(FAA, FRA, CG, FTA)
- Advanced display and communications applications  
(FAA, FRA, NHTSA, FHWA, CG, FTA)
- Passenger security  
(FAA, FTA)
- Aging  
(FAA, NHTSA, FHWA)
- Drugs and alcohol  
(NHTSA, FTA)
- Crew sizing/Work organization  
(FAA, CG, MARAD).

As shown above, top human factors concerns within the Department are the effects of fatigue, workload, aging, and drug and alcohol use on performance; the interaction between humans and automated systems; and the optimal crew size and work organization. For example, some of the fatigue and workload questions that the Department is looking at are how we can

quantify mental fatigue or workload and whether we can predict--before work starts--if an individual can perform safely during his or her scheduled shift.

Under automation, research is addressing the best division of mental workload between human operators and automated systems.

Advanced display and communication applications include display and control system designs that maximize information flow without distracting operators from other duties, and the best way to provide information to infrequent users of the transportation system.

Among other things, research on passenger security is looking at selection and training procedures for transportation security personnel.

Aging research seeks to determine objectively when an individual is too old to operate a vehicle or some other element of the transportation system safely.

Safety also will be enhanced by research on the effects on performance of alcohol and drug use. Specific research concerns include ways to quickly, objectively, and economically detect and measure drug use and performance effects.

And, finally, there is research on crew sizing and work organization. Here, a key objective is to determine the systems of crew training and scheduling that provide the safest and most productive outcomes as routine crew duties are automated.

Most of these programs are focused on the modal administrations' specific regulatory concerns or programmatic requirements. Unfortunately, because of the need to produce these types of program results, little opportunity has existed to pursue more fundamental human factors research. The human factors subcommittee has identified six key areas where additional human factors research could significantly improve the safety and productivity of the nation's transportation system:

- Data describing transportation operators and users
- Human performance measurement and analysis systems
- Models of transportation operator performance and user demand
- Models of human-in-the-loop transportation systems
- Application of human factors research to enhance efficiency
- Application of human factors research to realizing a seamless, more user-friendly transportation system.

Most of these research areas will require a long-term commitment and plan. The first need, and the reason that we are here today, is for information describing the baseline performance capabilities and limitations of the general population of transportation operators and

users--as well as that describing special subgroups such as the elderly and the physically challenged. Such data is essential to the design of new transportation systems.

The Department also needs to enhance its data-gathering capability. Simulators, instrumented vehicles, and other instrumentation and test sites are critical for measuring and analyzing human performance in transportation. Significant benefits would accrue from comprehensive analytical models of transportation users' and operators' sensory, cognitive, and physical characteristics. Another need is for models describing how both passengers and freight transportation users choose among the various transportation alternatives.

Next, the availability of integrated, interactive human-in-the-loop models and simulation capabilities would greatly facilitate the assessment of design alternatives. Yet another need is for applications of human factors research methods to enhance operator efficiency and productivity.

Finally, there is the need to apply behavioral science data and techniques to improving the presentation of information to transportation users. The development of accurate, timely, and use-friendly ways to access transportation information would improve users' abilities to choose among modes, and help to realize the Secretary's vision of a seamless transportation system.

These research efforts in human factors will be crucial to ensuring a safe and productive transportation system in the future. Many of these problems cannot be addressed adequately by a single mode or agency. Only by aggregating our resources can we bridge the knowledge gaps in human factors R&D.

Today's workshop represents an early step to maximize the impact of our scientific resources through R&D coordination. Our challenge today is to foster the collection and measurement of operator performance data with maximum cross-modal utility. To do this, we must:

- Determine what procedures and tools will foster the collection of human factors data that can be used by more than a single mode.
- Identify existing databases that can be interpreted or analyzed to support effective tactical and strategic decisions and policies.
- Recommend directions and topics for future human factors research that would have maximum cross-modal utility.

Ultimately, it is DOT's responsibility to assure the long-term safety, productivity, and efficiency of the nation's transportation system. To do this, the Department must support cross-modal research in human factors that will help us to realize our vision of a seamless, sustainable, and global transportation system.

# **Approaches To Measuring Operator Performance Across Transportation Modes**

*--R. Wade Allen, Systems Technology, Inc.*

## **ABSTRACT**

This paper attempts to discuss the measurement of human behavior and system performance across transportation modes in the context of human/machine systems including vehicles, automation and controllers. The range of human behavior of interest is reviewed along with its relationship to system performance. Experimental methodologies and measurement procedures are reviewed, and a list of transportation system challenges related to human performance are presented.

## **INTRODUCTION**

Human factors considerations in transportation systems typically involve the interaction of humans and machines and the ubiquitous human/machine interface. As suggested in Figure 1, the human element can include vehicle and system operators, maintainers and passengers. Although the emphasis of this paper is on the measurement of human behavior, and resulting system performance, a broad perspective on the interaction of humans, vehicles, systems and operations should be considered as suggested in Figure 2. Here it is implied that there is some union of human, machine, systems and operations that is relevant to a given problem, and the interaction of these considerations provides the context for experimental and/or operational measurements.

System performance concerns may include safety and/or optimum performance (Fisher, 1993) such as speed, efficiency, economy, capacity, etc. The tradeoff between safety and performance is often an issue (e.g. operations under poor environmental conditions). Trained, experienced and alert operator behavior coupled with normal vehicle behavior and environmental conditions should lead to desirable system performance. Inappropriate behavior on the part of both human operators and/or vehicle systems can lead to degraded performance and possible compromise in efficiency and/or safety of operations. Inappropriate human operator behavior can result from inadequate training, inexperience, impairment (fatigue, illness, stress, alcohol, drugs, etc.). Inappropriate vehicle system behavior can result from deteriorating system specifications, failures, or operational/environmental conditions beyond nominal performance envelopes (e.g. a skidding vehicle on a wet highway). Vehicle system behavior is not a primary issue here, but the human operators' ability to deal with adverse conditions (e.g. failure detection and compensation) in terms of training, experience and alertness is certainly at issue.

Transportation systems may involve a complex interaction of humans, vehicles and systems. For example, consider aircraft operations including the air traffic control system as portrayed by

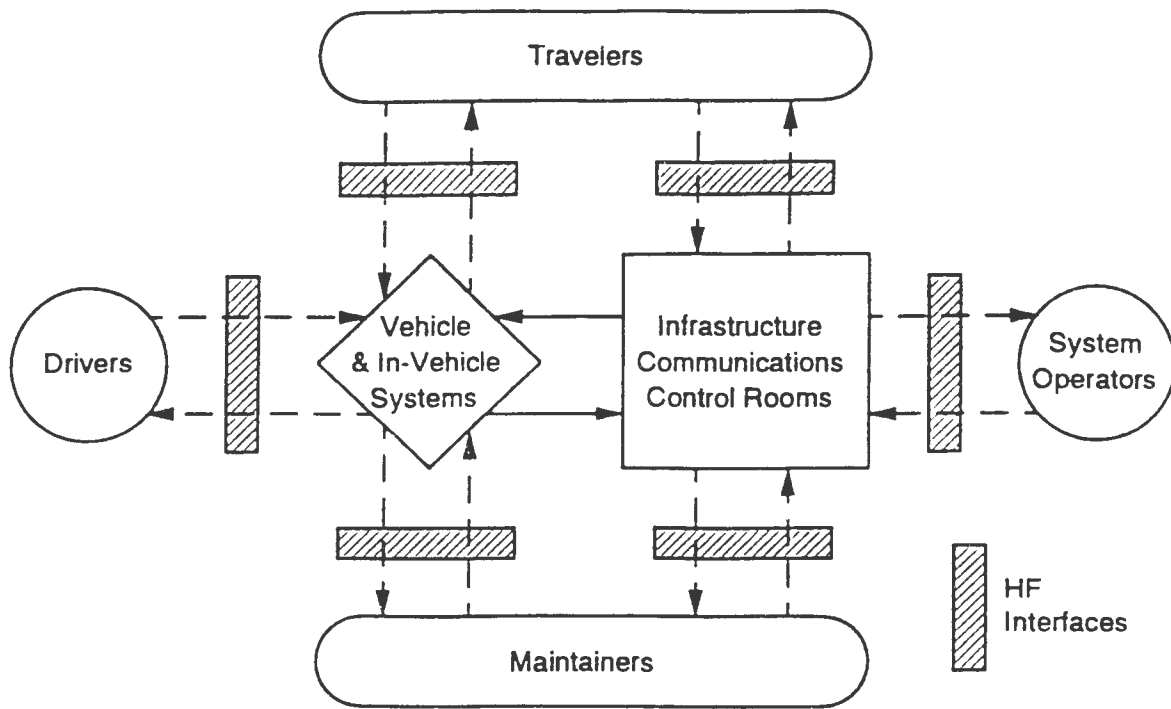

Figure 1. Generic Transportation System and Human/Machine Interfaces

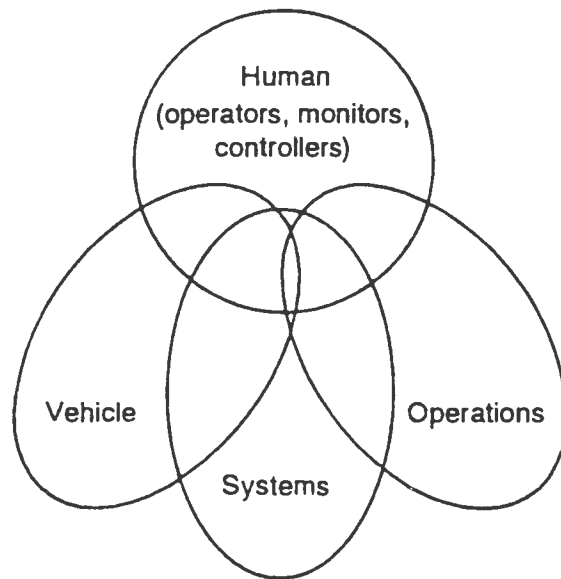

Figure 2. Intersection of Human, Vehicle, Systems and Operations Considerations in a Transportation System

the generic block diagram in Figure 3. Pilots have certain capabilities influenced by selection, training, experience, etc. Aircraft behavior depends on basic vehicle dynamics plus flight control system and other automation characteristics. Cockpit displays and modern, 'automated' flight control systems result in complex pilot/vehicle interactions. Operational considerations might include payload (passengers vs. cargo), weather, and air traffic control. The air traffic control system adds more human operators to the system, and when considering the cockpit crew and air traffic controllers, human/machine interaction is quite complicated. As IVHS technology comes on line with advanced traffic management systems, highway transportation may approach such complexity, albeit with much less control or regulation of the human element. The general problem of team performance (e.g. Baker and Salas, 1992; Driskell and Salas, 1992; National Plan for Aviation Human Factors, 1990; Sanquist, 1993) is important in a range of transportation systems problems.

Figure 3 indicates potential performance measures occurring at several points in a generalized human/machine system. The measurement of human behavior is directly of importance here, and could include the assessment of operating, monitoring, controlling and biodynamic response. Measures of workload (WL), performance and biodynamic response (ride) may all be of importance. In the overall human/machine context, subsidiary measures of system and vehicle performance may also be of interest because they may most directly relate to system safety and effectiveness (e.g. deviations from path, course or speed).

Human behavior of interest includes the range of abilities involved in human/machine interaction as indicated in Figure 4. Psychomotor and cognitive abilities are important to control, guidance and navigation of vehicles. Vigilance and attention (sustained and divided; Bennett and Flack, 1992) are important issues in maintaining alertness to primary responsibilities. Workload, stress and various impairments can have a negative impact on behavior, and sometimes result in random, perhaps inexplicable behavioral lapses referred to as human error (Nagel, 1988). From a measurement perspective the sensory/perceptual and biodynamic response components in Figure 4 are relatively straight forward compared to cognitive issues, but are nonetheless critical to the general human/machine problem in transportation.

Assuming that we have considered human/machine interactions, and determined behavioral issues of interest in a given situation, the measurement problem can be addressed. Some review and thoughts on this general topic are contained in a special issue of Human Factors (Meister and Enderwick, 1992). In general we must consider experimental methodology and design, measurement instruments, data acquisition, and data reduction and analysis. Each of these issues should be addressed early on to ensure that desired measurements can be made in a useful context, and that the data can be practically acquired and processed to result in meaningful results. Efforts that do not deal realistically with all these issues may be doomed to costly overruns, limited usefulness or complete failure in the extreme.

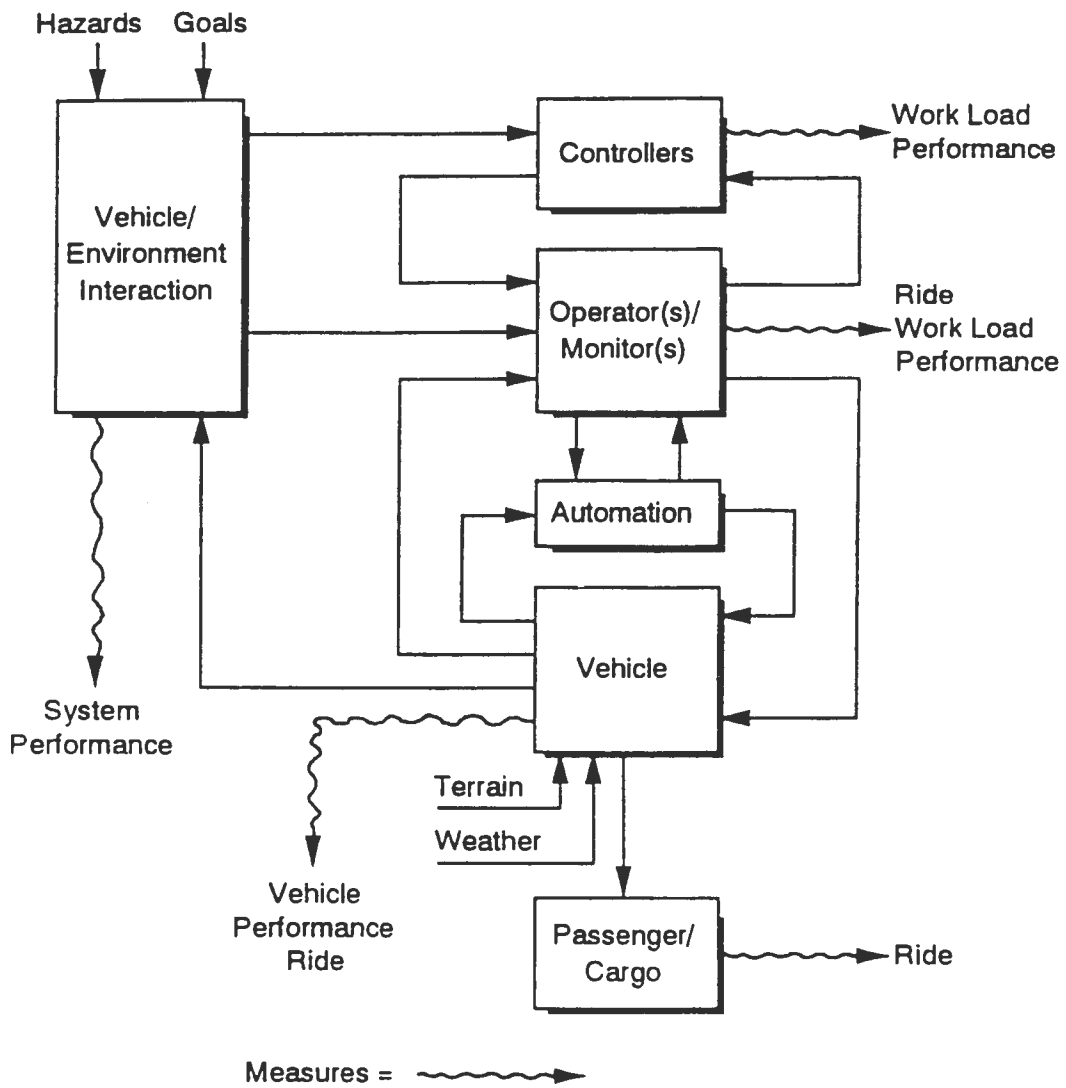

**Figure 3. Generic Dynamic Block Diagram for a Transportation System**

The remainder of this paper will review and discuss human performance measurement in the context of the above considerations and with specific examples. Some general background to the measurement problem is considered next.

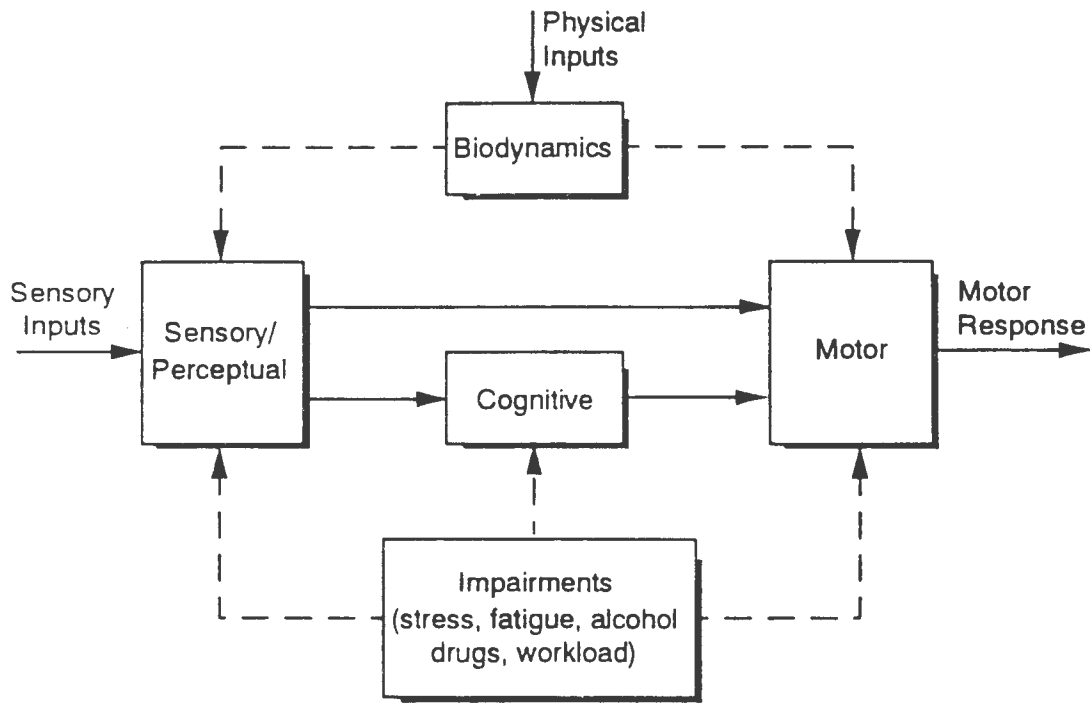

**Figure 4. Input/Output Relationships Between Human Behavioral Components**

**BACKGROUND**

A systems context is important for measuring human behavior and human/vehicle/system performance (Sheridan and Ferrell, 1974). The response properties and performance capabilities of vehicle systems and operational environment characteristics determine, to a large extent, potential measurement problems. One means of quantifying these characteristics is to consider the maneuvering and response envelope of various transportation modes as summarized in Table 1. For example, highway transport can result in significant vertical acceleration motions (and pitching motions for cab over truck designs) which may lead to ride quality concerns for operators (Jex et al., 1982). Aircraft vertical motions induced by rough air interfere with passenger service, comfort and safety. Rail operations can result in significant lateral acceleration motions which may lead to passenger comfort and acceptance concerns.

Vehicle maneuvering capability and system response can be a determining factor in the time scale demands on the human operator. At one end of the scale we have highway vehicles interacting with other vehicles and the highway environment on a very short time scale from the operator's point of view. The driver's primary responsibility is vehicle guidance and control, and very little time is left for dealing with in-cab systems. Highway vehicles also can maneuver relatively quickly, and accident avoidance actions operate on the same scale as human perceptual/reaction times and are clearly full attention tasks. Thus, measurements may relate to direct vehicle control, a driver's ability to share attention with the primary control and guidance task, and the effect of impairments or environmental disturbances on driver attention. At the other extreme we have marine operations where vehicle maneuvering (i.e. slowing, turning) can take on the order of tens of minutes and guidance and navigation involves longer term strategy and decision making. While aircraft operations such as takeoff and landing provide an



**Table 1.**  
**Transportation System Operational Conditions**

| VEHICLE  | CRITICAL RIDE MOTIONS              | MANEUVERING MOTIONS                                   | TIME RESPONSE             |
|----------|------------------------------------|-------------------------------------------------------|---------------------------|
| Highway  | Vertical<br>Pitch (cab over truck) | Lateral; .4-.7g<br>Longitudinal; .2-.8g               | 0.1-0.3 seconds           |
| Aircraft | Vertical<br>Roll/Pitch             | Lateral; 0.5g<br>Longitudinal; 0.2g<br>Vertical; 1.0g | 0.5-2.0 seconds           |
| ATC      | None                               | None                                                  | seconds to minutes        |
| Rail     | Lateral                            | Longitudinal; 0.5-1.0g                                | 10s of seconds            |
| Marine   | Vertical<br>Pitch/Roll             | Lateral; 0.05g<br>Longitudinal; 0.05-0.1g             | minutes to 10s of minutes |

intermediate time scale, interactions with the air traffic control system clearly lengthen this time horizon (analogous operations will most likely occur with advanced highway traffic management systems).

The requirements placed on the human operator, and consequently the measurement of human behavior and system performance of interest, vary considerably across modes as suggested in Table 1. Human operator behavior of interest varies with the length of the important time horizon for a given mode. Perceptual/reaction time and direct vehicle control are of significant interest in highway vehicle operations. Strategy, planning and decision making become more important as we proceed to longer time horizon tasks such as air traffic control and marine operations. Selection, training and experience also become more important with increasing operations time horizons.

The vehicle/operational environment context discussed above gives some indication of important human performance measurement and analysis issues across transportation modes as summarized in Table 1. Ride quality and human biodynamic response change relative to motion axis, but considerations such as amplitude, frequency and timing of motion are similar for highway vehicle, aircraft and rail (Jex and Allen, 1974). Lower frequency motions become more important in aircraft, rail and marine operations, leading to motion sickness considerations. Human operator guidance and control is quite important in the case of highway vehicles and aircraft operations such as takeoff and landing involving high frequency, continuous operation.

Beyond guidance and control, situation awareness (Pew, 1994) becomes important on a longer term time scale. Furthermore, the situation awareness time scale increases as we proceed from highway operations to aircraft, rail and marine operations. Situation awareness in the context of this paper involves operator cognizance of potential hazards or circumstances unfolding in time that could impact system safety and/or performance. Situation awareness initially involves perception of all pertinent information, plus other cognitive skills required to interpret the kinematic consequences of a given situation. Given situation awareness, decision making on appropriate actions becomes important.

The guidance, control and situation awareness skills of the human operator can be impaired by a variety of work related and other types of impairments. Fatigue and alertness are the most ubiquitous concerns in commercial operations, having to do with shift scheduling, rest opportunities and the circadian cycle (Brown, 1994; Rosekind et al., 1994). Prescription and illicit drugs, alcohol, illness and stress are also of significant concern. Vigilance is of concern in transportation operations during long periods of inactivity and minimal environmental stimulation (Mackie, 1977). Task sharing, divided attention and distraction also become critical in highway vehicle and aircraft operations where the human operator is involved in use or monitoring of vehicle systems during critical guidance and control activity (Bennett and Flach, 1992; Wickens, 1989). This area is of serious concern with the implementation of IVHS technology (Sheridan, 1994).

Given the above considerations, we still have several basic issues to confront regarding measurement of human behavior and system performance. Is a given behavior or performance observable and quantifiable? (e.g. situation awareness is an interesting and useful concept, but how do we measure and quantify awareness?) What measurement techniques, experimental designs and procedures do we use to obtain quantitative data. Finally, given quantifiable effects, can we develop models to aid in future design or to help structure additional research?

## **BEHAVIOR AND PERFORMANCE MEASUREMENT**

Measurement issues in human/machine systems can be conceptualized with the aid of a block diagrams such as Figures 3 and 4 which portray dynamic interactions. Clearly, the behavior of both the human and machine elements contribute to ultimate system performance. Some elements of human behavior are fairly basic, and can be measured in isolation (e.g. visual, auditory and proprioceptive function). Other characteristics depend on training, experience and task context due to behavioral adaptation to operating conditions. It is important to distinguish between measures of human behavior versus system performance, and measure both, if possible, in a coordinated manner. Measurement considerations for the Figure 4 components of human operators and controllers are as follows.

### **Sensory/Perceptual**

Functioning of the basic human sensory apparatus depends on individual variation, age and environmental exposure, but is relatively insensitive to training, experience or adaptation to task

demands. A good summary of basic visual, auditory and proprioceptive sensory behavior can be found in Boff and Lincoln (1988); Boff et al., 1986; NASA, 1989). Thresholds, resolution and intensity scaling seem to be relatively independent of adaptation, training and experience. Perceptual interpretation of sensory inputs can be sensitive to task context, training and experience as exemplified by visual search and complex auditory perception tasks (Boff and Lincoln, 1988).

### **Stimulus/Response**

A variety of vehicle command and control tasks require motor activity in response to sensory inputs where behavior depends on the sensory channel, the complexity of the sensory/perceptual information and the nature of motor task. Simple reaction time is a fairly basic behavior, but multiple choice reaction times involve additional procession time. Measurements of driver perception response time show a significant dependence on expectation (Olson and Sivak; 1989). Going beyond discrete stimulus/response situations, vehicle guidance and control requires human operator responses that are some function of sensory/perceptual inputs such as errors relative some desired path or course (e.g. Allen et al., 1988). Depending on the vehicle system, these responses are a strong function of training and experience (e.g. helicopter piloting which requires significant experience to achieve smooth, stable attitude control).

### **Cognitive**

The guidance and navigation of vehicles moves beyond simple stimulus/response relationships and involves higher mental functions involved in situation awareness, decision making, reasoning, problem solving, etc. (e.g. piloting a ship in the vicinity of a congested port facility). These higher level functions are required for the human operator(s) and controller(s) to deal with complex situations that may allow for a range of alternative actions and require complex judgments about what alternative(s) to select. Situation awareness (SA) describes the complex perceptual input needed for decision making amongst alternative actions, and has been operationally defined as "...knowing what is going on around you," (Hollister, 1986). SA has been defined more generally as a mental model of the surrounding (immediate) world (Endsley, 1988a), or attention allocation to a 'focal region' (Fracker, 1988). The focal region for A can include displays, the outside visual scene, and communications amongst crew members and controllers.

Situation awareness is a relatively new concept (Pew, 1994) involving the perception of the kinematics of environmental elements in time and space and the consequences of potential interaction. This is an extension of general perception that is quite relevant for transportation vehicle operations, and relates to the ability of human operators, controllers and monitors to observe complex processes and perceive hazards or desired goals. Situation awareness involves basic visual and auditory perception, but also invokes the ability to predict relative motions, and perhaps keep track of several potentially hazardous situations.

Given SA, the human operator(s) then must deal with decisions regarding alternative actions that can lead to various outcomes that may have a variety of consequences for system safety and performance. Human operators and controllers presumably account for these consequences in the selection of control actions and commands involved in guidance and navigation decisions.

With the proliferation of computer augmentation and control in transportation systems, the human/machine interface is becoming increasingly more complex and challenging to the cognitive capabilities of operators, controllers and users. This complexity extends to displays, system functionality and human/system interaction (Bennett and Flach, 1992; Parasuraman, 1987), and there is some concern that computer 'automation' may be adversely affecting safety (Wiener and Curry, 1980; Kirlik, 1993). The mental model concept (an internal perception of system behavior) provides a means for understanding how humans deal with complex systems and may potential paradigms for measurement although there is some concern for its application in human factors (Wilson and Rutherford, 1986). The human operator's understanding of the operation of a complex system, such as modern aircraft avionics, will be critical in dealing with human/automation interaction problems.

### **Attention, Workload, and Fatigue**

The operation, direction and monitoring of complex transportation systems involves vigilance, attention (focused and divided), complex cognitive activity and actions on the part of human elements to maintain safety and performance. On one extreme, with highly automated systems, there is concern that humans are poor passive monitors over significant time periods, and at the opposite extreme, that complex information displays and environmental activity far exceed human attentional capacity (Hancock and Warm, 1989; Parasuraman, 1987). These issues provide significant human factors measurement opportunities. On one hand, it will be of interest to understand the complexity of tasks (e.g. Chechile et al., 1989; Koelega et al., 1989), and on the other hand, measuring the stress and workload imposed on the human elements will be of concern (Hendy et al., 1993; Hill et al., 1992). Wierwille and Eggemeier (1993) provide a good review of mental workload measurement techniques.

In sustained operations, there is the general concern for mental and physical fatigue that result from task complexity, time on task and shift scheduling (Brown, 1994; Rosekind et al., 1994). Fatigue can lead to errors of omission and commission during critical high workload operations, and drowsiness induced inattention during low workload periods. Measurement of performance, workload, attention, and psychophysiological state may be relevant for specific applications.

### **EXPERIMENTAL METHODS**

Useful human factors data can be collected under a variety of circumstances from the laboratory to real world operations. Laboratory studies can include part-task approaches, in which specific behavior is measured, to full fidelity simulation which attempts to give a complete

and realistic sensory environment to the human monitor, controller or operator. Research in the real world can range from instrumented operations run under controlled conditions to observation of uncontrolled real world operations. The advantage of laboratory research is the ability to control experimental conditions, to obtain desirable measures and to conduct testing under relatively safe conditions. Problems with laboratory research include the fidelity of the tasks or simulations and subject motivation relative to real world risks.

Testing in the real world is not necessarily a panacea. If testing is conducted under controlled conditions (e.g. vehicles on test tracks), operational conditions may be seriously constrained, and subjects may still not behave as they do naturally under uncontrolled conditions. Uncontrolled observation provides the most realistic human behavior if data can be collected under desired conditions. Traffic engineers traditionally collect observational data on uncontrolled drivers (ITE Traff. Engr. Handbook) as is the case for the safety evaluation of IVHS demonstration projects (Burgett, 1994). There is also the possibility of installing data collection systems on vehicles and collecting information on an uncontrolled basis (Morrison, 1994). The challenge with uncontrolled observation is in data reduction since the majority of data will be uninformative because it does not relate to conditions of interest. This is an area where sophisticated, automated data screening procedures are needed.

## **MEASUREMENT PROCEDURES**

Measurement procedures involve a range of techniques from opinion surveys and rating scales for recording subjective impressions, to instrumentation, data acquisition and processing systems for objective and quantitative assessment of human behavior and system performance. Selection of measurement procedures will depend on objectives, budgetary constraints and available resources, as well as the specific behavior or performance of interest and the intended experimental methods as discussed above. Consideration must also be given to the expected reliability and validity of a measurement procedure in a given context, and the overall appropriateness of a procedure for a specific variable to be measured.

Questionnaires and rating scales provide one of the most economical means for collecting data, given that the system and environmental conditions of interest are readily available for testing. Subjective ratings are a direct indication of human reaction to system behavior and environmental conditions, they produce minimal intrusion because they can be administered after the completion of a task, exposure or mission, and they are easily administered and analyzed. Rating scales have been used for handling qualities of aircraft and highway vehicles (Cooper and Harper, 1969; McRuer and Klein, 1976), operator workload (Hendy, 1993; Hill, 1992), ride quality (Broderson, 1973), and ad hoc rating scales are often developed for specific applications (McRuer and Klein, 1976). Sensory scaling techniques (judging the relative intensity of sensations) has been used widely for sensory phenomena such as auditory display characteristics (Edworthy et al., 1991; Hellier et al., 1993).

Beyond rating techniques, we face the development and application challenges of instrumentation and data acquisition systems, and computer data processing for measuring human and system behavior and performance. Instrumentation for human behavior includes psychophysiological sensors (e.g. heart rate, breathing rate, GSR, EMG, EEG, EOG), eye point of regard (EPR), and motor activity (e.g. limb position and force). Visual and auditory sensory measurements can require relatively sophisticated presentation display apparatus and instrumentation.

More complicated stimulus/response measurements of human behavior can require relatively sophisticated computer processing procedures and measurement paradigms to determine the input-output relationship of the human operator, monitor or controller. At this level of measurement there are several paradigms that deal with the human as an observer/monitor, a psychomotor control element, a decision maker, or a physical dynamic system responding to motion.

Human monitoring behavior has been described in terms of signal detection theory or SDT (Green and Swets, 1966) which has been applied to the vigilance problem (Craig, 1987). The SDT paradigm allows defining the relationship between target detection and false alarms, where transportation system 'targets' could be hazards, off-nominal vehicle operating conditions, etc. STD allows the quantification of the statistical properties of human observation and monitoring, and can be used to measure changes in behavior due to changes in operating conditions, impairment (e.g. fatigue), etc. While vigilance and attention are considered to be significant practical problems in transportation safety, it should be noted here that there is considerable concern that a great deal of academic research has been conducted that is difficult to apply to practical problems, and that more research is needed with real or simulated real world situations (Adams, 1987; Mackie, 1987).

A procedure for measuring dynamic stimulus/response (psychomotor) relationships in human/machine systems is summarized in Figure 5. This approach has been referred to in the manual control literature as describing function analysis, and attempts to model the human operator as a linear transfer function which also adds noise or uncorrelated response actions to the system. As indicated in Figure 5 this approach accounts for both human operator behavior and system performance. The data reduction procedures for this measurement analysis are referred to as spectral or harmonic analysis and an efficient processing algorithm is referred to as the Fast Fourier Transform (FFT). This approach has been applied to driver behavior (e.g. Good and Baxter, 1986; Smiley et al., 1980) and pilot modeling (McRuer, 1980). This approach is particularly appropriate where the dynamic response and controllability of vehicles is of concern, and the human operator must be described in the same context. This approach has the ability to measure subtleties in human behavior that might not be revealed by other performance measures.

The measurement of cognitive behavior is generally quite varied because of the wide range of characteristics exhibited by human monitors, controllers and operators. One paradigm particularly relevant to transportation systems involves decision making and risk taking. The

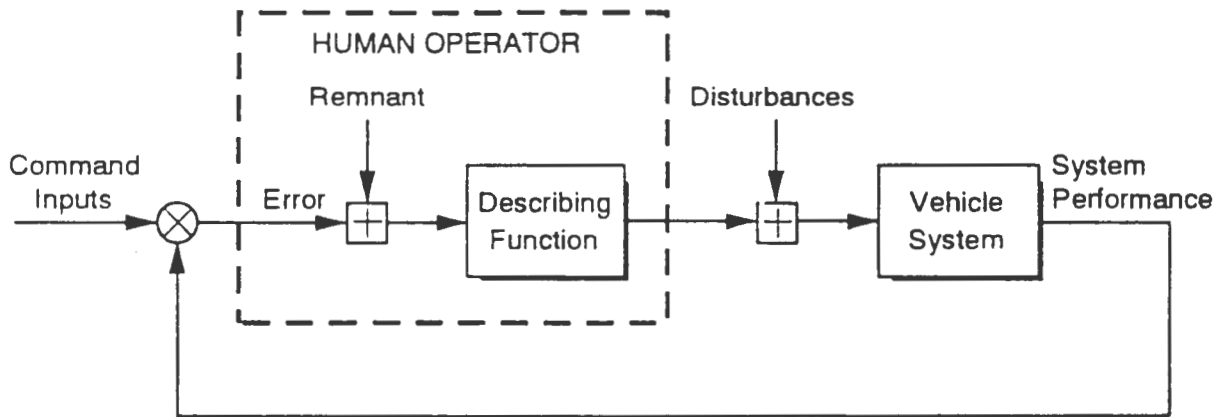

**Figure 5. Human/Machine Dynamic Response Measurements**

human operator as a decision maker is faced with various alternative actions (decisions) that have risks and rewards or penalties associated with them (e.g. pilots deciding to take off or abort, drivers deciding on gap acceptance). Given the probability of success of various alternatives, and the cost of success or failure, how does the human operator behave as a decision maker? Some decision makers follow a rational process of selecting the decision with the highest expected value (which takes into account the probability of success or failure and the costs of the alternatives), while other decision makers seem to be risk adverse or risk takers (McRuer et al., 1985). An experimental approach using this paradigm requires setting up tasks with decision points and definable alternatives, risks and costs (Sheridan and Ferrell, 1974). A example of pilot decision making is discussed below.

## SELECTED EXAMPLES

### Psychomotor Behavior

Highway transportation has generated a great deal of interest in driver behavior relative to vehicle characteristics, environmental conditions, and driver condition. Driver steering control involves psycho-motor behavior, which is responsible for vehicle lateral lane position, a primary, safety related system performance variable. The Standard Deviation of Lateral lane Position (SDLP) has been used as a primary safety metric in the study of delineation treatments (Allen and O'Hanlon, 1979) and drugs (O'Hanlon et al., 1986). SDLP can be interpreted as a surrogate measure of potential accident involvement by approximating the probability of lane edge exceedance as shown in Figure 6 which gives an interesting nonlinear interpretation to SDLP. For levels below 25 cm (0.8 ft) the lane exceedance probabilities are quite small, and virtually vanish in the region of 20 cm (0.6 ft). This is a typical SDLP level for unimpaired drivers under good driving conditions. When SDLP reaches levels of 25-30 cm (0.8-1.0 ft) the probability of lane exceedance is significant and this region represents serious driver impairment or seriously degraded driving conditions.

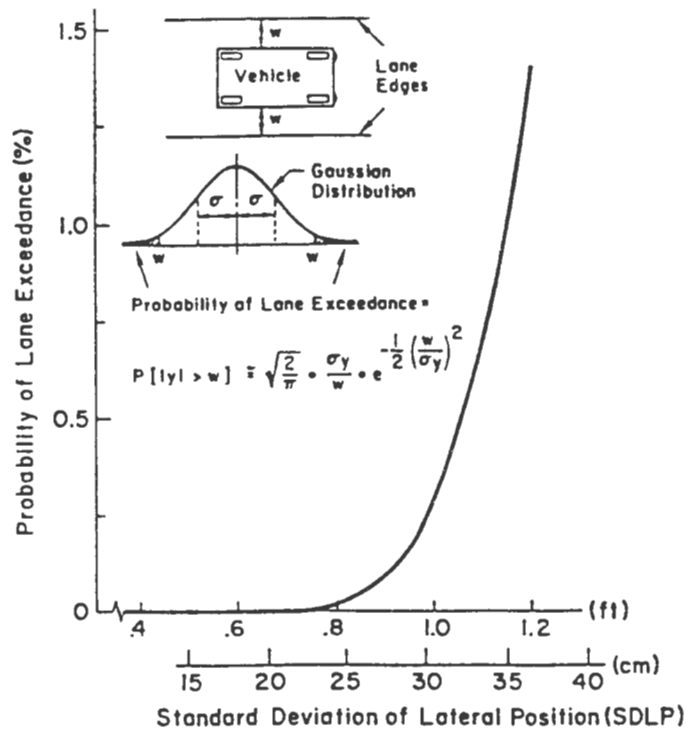

**Figure 6. Traffic Safety Interpretation for the Standard Deviation of Lateral Lane Position (SDLP)**

Two examples of research use of the SDLP metric are of interest here. In an in-vehicle, public highway study of the acute effects of antidepressants (Louwerens, Brookhuis and O'Hanlon, 1986) it was found that drivers receiving a large dose had an SDLP on the order of 30 cm (1.0 ft), and also resulted in 6 terminated runs due to safety concerns. In a second example, SDLP measures of the effects of delineation visibility were made in both a driving simulator and out on a public highway (Allen and O'Hanlon, 1979) and the results are portrayed in Figure 7. SDLP was found to increase with decreased road marking contrast, and reasonable agreement was obtained between field measurements and a model based on simulator performance.

It should be emphasized that SDLP is a system performance measure but has been used routinely as a measure of driver behavior. It is also possible to obtain measures of the driver's psychomotor behavior in terms of transfer functions and uncorrelated noise or remnant. This was accomplished in the above road marking study and an earlier study by another investigator where it was found that reduced visibility conditions interfere with the driver's ability to predict road curvature (Allen and McRuer, 1977; Donges, 1978). More recent roadway delineation research (Good and Baxter, 1986) has also employed this paradigm for measuring the driver's dynamic stimulus/response behavior. The transfer function paradigm has also been employed extensively to measure pilot behavior in tasks such as target tracking and landing approach (e.g. McRuer, 1980).



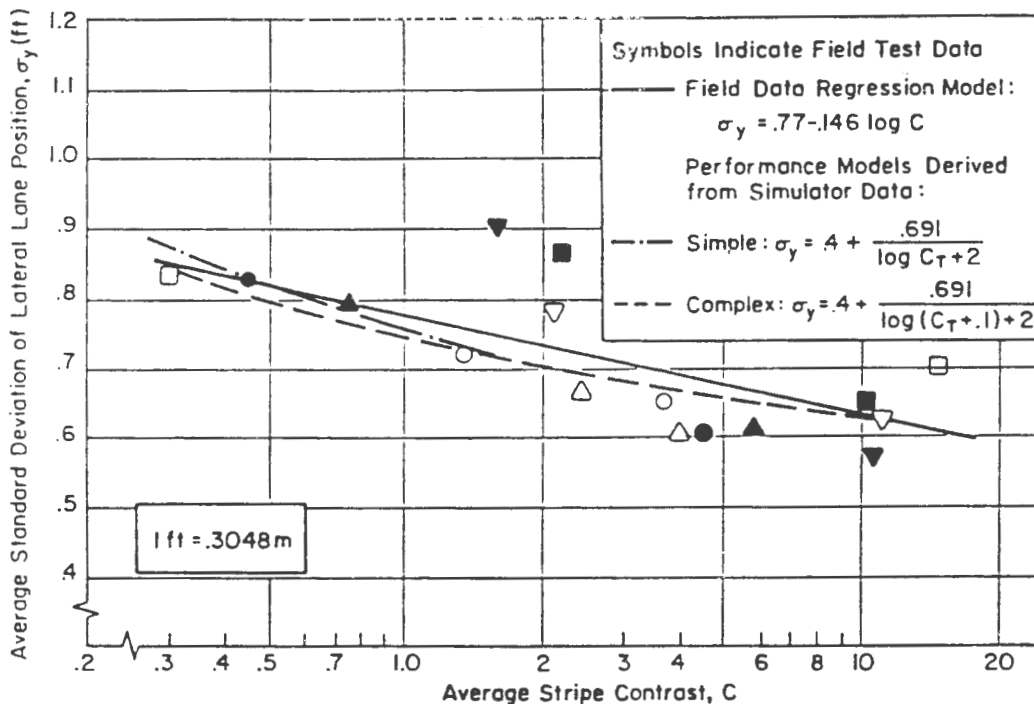

Figure 7. Effect of Roadmarking Contrast on SDLP

## Cognitive

In aircraft operations, safety related flight management scenarios involve a variety of cognitive demands on the aircrew, including situation awareness, decision making and associated workload. As noted in Figure 8, accidents occur mainly during takeoff and landing (roughly 85%), and these accidents are primarily associated with human error (Nagel, 1988). The takeoff and landing flight phases are critical because of the high workload associated with complex situations and time constraints. It is here that attention should be focused on situation awareness (SA) and the concomitant decision making (DM) that impact on safety of operations.

Takeoff, approach and landing flight phases require dynamic decision making where the environment is continually changing due to the aircraft's translation along a flight or ground path, and to crew actions and ATC directions as a scenario unfolds. In this dynamic environment, crew situation awareness is a critical component of required decision making. As suggested in Figure 9 the crew must account for basic aircraft performance, automated system functioning, the environment (weather and other traffic) and ATC interactions and base decision making on their situation awareness.

The "focal region" for SA can include the cockpit instrument panel, particularly under IFR conditions, the outside visual scene, and communications amongst the crew and with ATCs. Given this array of potential information sources, aircrew activities associated with achieving adequate SA combined with aircraft navigation, guidance and control responsibilities can impose significant levels of workload. The ultimate objective of enhancing SA is achieved by providing better quality input to the human operator such as whether to continue or abort, or to change control strategies during severe windshear encounters.

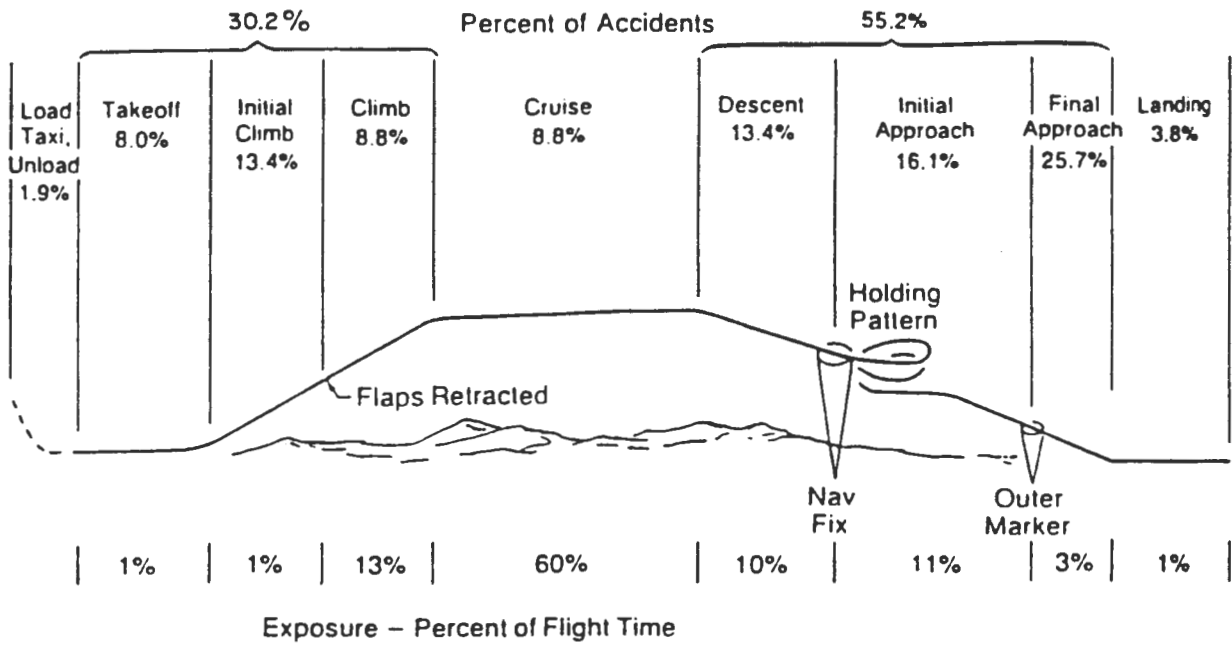

**Figure 8. Air Carrier Accidents Distributed by Phase of Flight, 1959-1983: World Wide Jet Fleet, All Operations. (Excludes Sabotage and Military Action) Exposure Percentage Based on an Average Flight Duration of 1.6 Hours.**

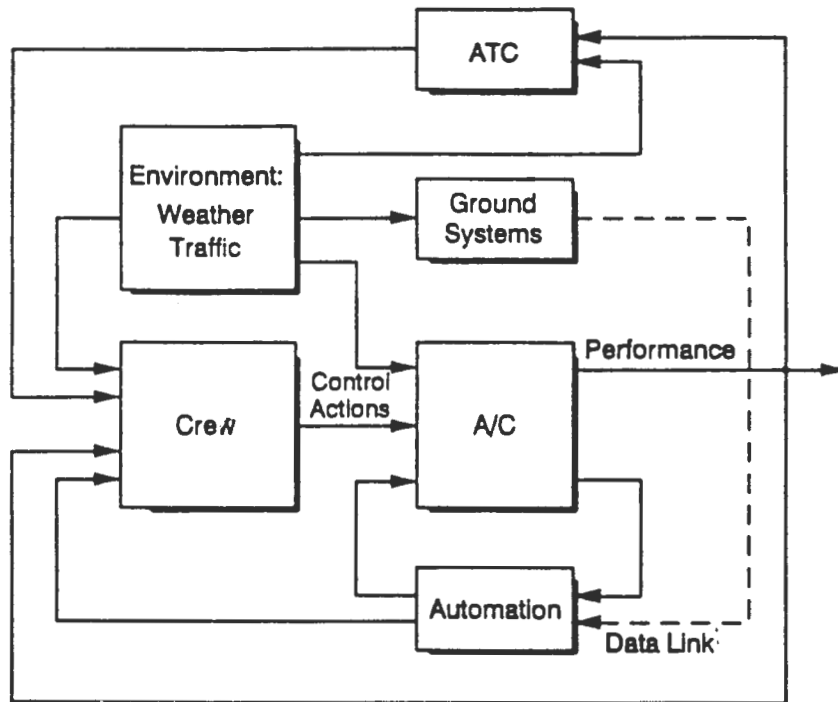

**Figure 9. Crew Interaction with Aircraft and Automated Systems, Ground System and Air Traffic Control**

An interesting example of situation awareness and decision making measurement involved pilots dealing with wind shear situations which required them to assess the need for avoidance decisions (approach go-around or takeoff abort, Krendel, E.S. et al. 1988). This approach presented pilots with a sequence of scenes of out-the-window and instrument panel cues typical of take-off or landing conditions. Scenarios were developed using actual in-flight data records from accident investigations (Windshear Training Aid, 1987). Given slides once every five seconds, pilots were asked to rate the probability of windshear encounter according to the scale shown in Table 2 developed from the FAA Windshear Training Aid. This approach essentially gave a measure of SA once every five seconds throughout landing and take-off scenarios. The subjects were assumed to be the pilot-not-flying, and their responses were indicated by pressing keys in a response box. The slides were automatically administered and the responses recorded with a personal computer.

**Table 2.**  
**Situation Awareness (Windshear Hazard) Ratings**

| <b>RATING</b> | <b>SUBJECTIVE PROBABILITY</b> | <b>DESCRIPTION</b>                                                                                                                                  |
|---------------|-------------------------------|-----------------------------------------------------------------------------------------------------------------------------------------------------|
| #1            | None                          | There is no reason to expect a Microbust.                                                                                                           |
| #2            | Low Probability               | Consideration should be given to this observation, but a decision to avoid is not generally indicated                                               |
| #3            | Medium Probability            | The weighing of this observation is relatively significant, and there should be some serious consideration of an avoidance decision.                |
| #4            | High Probability              | A pilot should give critical attention to this observation, and a decision to avoid should clearly be made under these observational circumstances. |
| #5            | Windshear                     | You are encountering a windshear!                                                                                                                   |

Source: Windshear Training Aid (1987)

Results for 24 airline pilots in the above study are summarized in Figure 10 under several different windshear warning conditions. The average of the Table 2 ratings made during each succeeding slide presentation provide a general measure of situation awareness. Both of these scenarios should have resulted in aborts, and the slide at which each pilot aborted is indicated in the Figure 10 distributions. The accumulated time required for each pilot to rate the slides and ultimately reach an abort decision is indicated in Figure 11. Note that some pilots did not feel the takeoff scenario was serious enough to warrant an abort (remember these scenarios were taken from actual accidents).

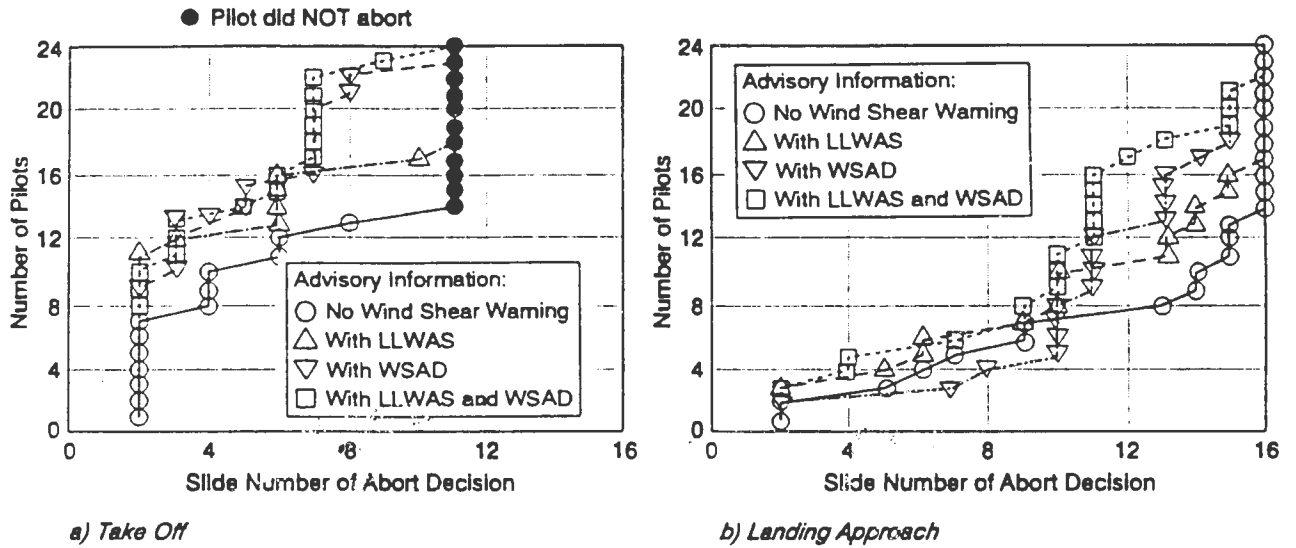

Figure 10. Distribution of Scenario Slide Number at Which Each Pilot Aborted

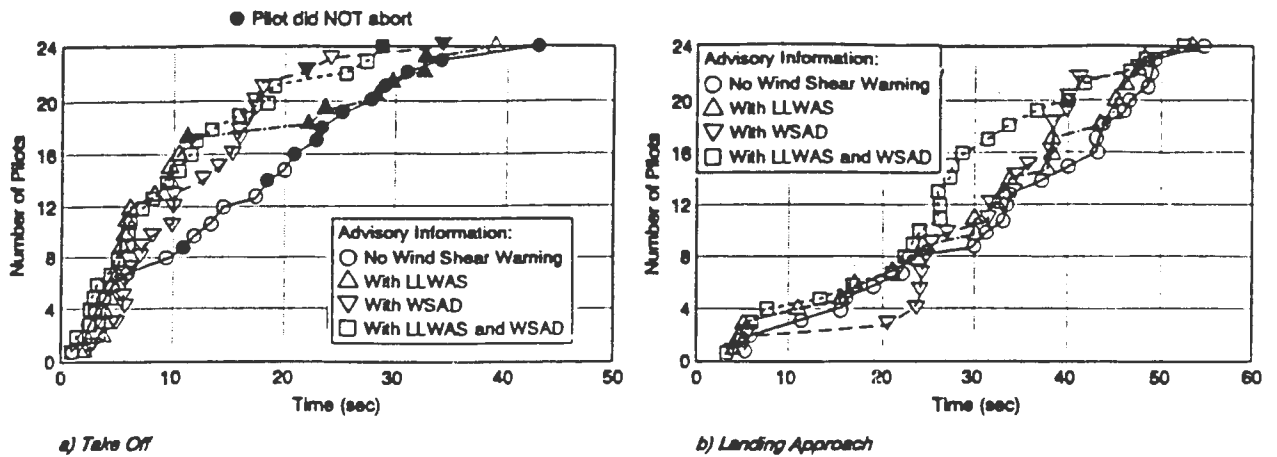

Figure 11. Distribution of Accumulated Rating Response Times Up to Abort Decision

In this experiment it is alleged that the rating technique gave a continuous measure of SA (situation awareness) throughout the landing and takeoff scenarios. The rating was directly relevant to pilot flight management decision making, specifically whether to continue on or abort landings and takeoffs, and induced minimal interference in the pilots' task. There was a

reasonable distribution in pilot ability to perceive the windshear hazard scenarios, and additional feedback on windshear conditions (advisory information) improved pilot SA.

The above approach also implies a decision making paradigm as summarized in Figure 12 where the pilot must decide at various points in a landing approach or take off whether to continue with the flight phase, or to abort. The decision is not a simple one, however, because there are potential penalties for either decision as indicated. A model for this process must take into account the possibility that various outcomes might occur, and in some sense weight the various outcomes according to subsequent consequences. The rational decision maker would then select the most attractive outcome in terms of minimizing penalties and/or maximizing payoffs (McRuer et al., 1985).

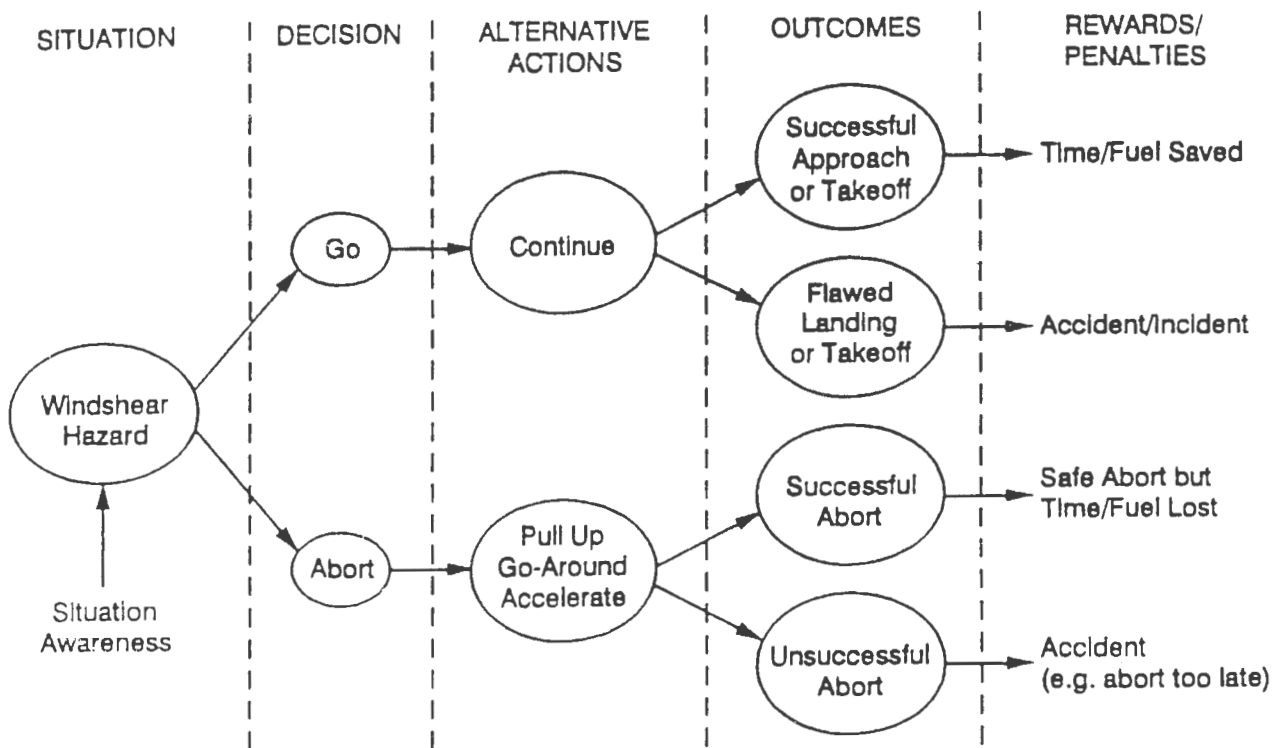

Figure 12. Landing Approach/Takeoff Decision Tree

### TRANSPORTATION CHALLENGES

The need for human factors measurement has been identified in several modes. The NHTSA makes an appeal for design-relevant measurement protocols and takes a first cut attempt

at identifying variables and measurement approaches (Clarke et al., 1994). The lack of applied research data has also been noted relative to maritime safety issues such as the impact of reduced manning on emergency response capability, appropriate design approaches to automating navigation tasks and the impact of regular sleep disruptions on acute and chronic fatigue (Sanquist et al, 1993). The development of better research methodology and techniques for measuring human performance are also noted in the National Plan for Aviation Human Factors (1990), particularly in the areas of coordination and communication in flight crews, and ATC and maintenance teams, and the impact of automated systems on team performance.

Triggs et al. (1991) discuss a series of human factors issues which are critical to transportation safety and productivity, and they examine the potential benefits that can be realized using a multi-modal approach to human factors research. Based on Triggs et al. cross-modal topics, critical human factors measurement issues can be summarized as follows:

### **System Automation and Complexity**

Systems are becoming increasingly more complex from the user's point of view, and we are still extremely limited in our ability to quantify this complexity a priori without some empirical work on a given system. Without a general framework for complexity assessment, new systems with significant complexity must be dealt with on an individual basis, and rating techniques and performance measures (e.g. errors, task completion time) in simulators or with real systems will be required to deal with present day problems. On a longer term basis, basic research is needed to develop procedures for quantifying the complexity of a system from the user's point of view (sort of a cognitive quotient). Ultimately, we would like to define guidelines for system design that would provide rules for limiting the cognitive complexity of a system to a given level (say in terms of total number of states, hierarchical levels, and display formats), and simple ways of prototyping new systems that would allow for the measurement and resolution of complexity issues (similar to computer software and interactive display testing).

### **Operator Impairment**

Impaired operators challenge the safety of transportation systems. Impairment can include fatigue, emotional stress, alcohol, legal and illicit drugs, in general any condition that significantly deteriorates human performance from a safety and system performance point of view. Measurement will be required to set rules for scheduling and hours on task, and proscribing ingested substances. Measurement methods may also be needed to routinely screen operators (i.e. fitness-for-duty testing) prior to admittance to critical job functions .

### **Selection, Licensing, and Screening**

Comprehensive testing and measurement procedures are needed for the selection and licensing of new operators, relicensing of experienced operators, and screening for the effects of aging. Testing is common in commercial aviation, and under consideration for commercial truck

drivers. Low cost computerized and simulation test and measurement procedures will be required to handle this on a comprehensive basis. Aging is idiosyncratic, and comprehensive screening procedures rather than arbitrary age limits are needed to identify capabilities and to detect safety critical deterioration due to effects of early aging or acute medical conditions.

## **CONCLUDING REMARKS**

The measurement of performance in a human/machine system context is critical to human factors research objectives in all transportation modes. General measurement paradigms and procedures can be defined, but the operational context changes somewhat between modes. The proliferation of powerful, low cost PCs and related instrumentation and data acquisition equipment allows a considerable freedom in data collection and processing. The challenge will be to assemble the necessary hardware and software and build up user skills in its application. Cost constraints should no longer be a serious limitation to successful applications.

## REFERENCES

- Adams, J.A. (1987). *Criticisms of Vigilance Research: A Discussion*. *Human Factors*, 29(6), 737-740.
- Allen, R.W. and McRuer, D.T. (1977). Driver Steering Dynamics Measured in a Car Simulator under a Range of Visibility and Roadmarking Conditions. In *Proceedings of the 13th Annual Conference on Manual Control*, pp. 15-17. National Aeronautics and Space Administration, Washington, DC.
- Allen, R.W. et al., (1988). Dynamic Systems Analysis Programs with Classical and Optimal Control Applications of Human Performance Models, NATO RSG9 Workshop, Orlando, FL. Systems Technology, Inc. Technical Paper 421, Hawthorne, CA.
- Allen, R.W. and O'Hanlon, J.F. (1979). Effects of Roadway Delineation and Visibility Conditions on Driver Steering Performance, *Transportation Research Record 739*, Transportation Research Board, US National Academy of Sciences, Washington, DC.
- Baker, D.P. and Salas, E. (1992). Principles for Measuring Teamwork Skills. *Human Factors*, 34(4), 469-475.
- Bennett, K.B. and Flach, J.M. (1992). Graphical Displays: Implications for Divided Attention, Focused Attention, and Problem Solving. *Human Factors*, 34(5), 513-533.
- Boff, K.R. et al. (1986). *Handbook of Perception and Human Performance*. John Wiley and Sons, New York.
- Boff, K.R. and Lincoln, J.E. (1988). *Engineering Data Compendium: Human Perception and Performance*, AAMRL, Wright-Patterson AFB, OH.
- Burgett, A.L. Methodologies for Evaluating the Impact on Safety of Intelligent Vehicle Highway Systems. Conference on Enhanced Safety of Vehicles, Paper 94 S3 O 12.
- Broderson, A.B. (1973). *Measurement, Evaluation, Prediction and Improvement of Aircraft Ride*, AMRL-TR-73-4, Wright Patterson AFB, Dayton, OH.
- Brown, I.D. (1994). Driver Fatigue. *Human Factors*, 36(2), 298-314.
- Chechile, R.A. et al. (1989). Modeling the Cognitive Content of Displays. *Human Factors*, 31(1), 31-43.
- Clarke, R.M. et al. (1994). Driver Performance and IVHS Collision Avoidance Systems: A Search for Design-Relevant Measurement Protocols.



- Cooper, G.E. and Harper, R.P. (1969). *The Use of Pilot Ratings in the Evaluation of Aircraft Handling Qualities*, (NASA TN-D-5153), Moffett Field, CA: NASA Ames Research Center.
- Criag, A. (1987). Signal Detection Theory and Probability Matching Apply to Vigilance. *Human Factors*, 29(6), 645-652.
- Donges, E. (1978). A Two-Level Model of Driver Steering Behavior. *Human Factors*, 20, 691-707.
- Driskell, J.E. and Salas, E. (1992). Collective Behavior and Team Performance. *Human Factors*, 34(3), 277-288.
- Edworthy, J. et al. (1991). Improving Auditory Warning Design: Relationship between Warning Sound Parameters and Perceived Urgency. *Human Factors*, 33(2), 205-231.
- Elkind, J.I. et al. (1989). *Human Performance Models for Computer-Aided Engineering*, National Academy Press, Washington, DC.
- Endsley, M.R. (1988a). Situation Awareness Global Assessment Technique (SAGAT), *Proceedings of the National Aerospace Electronics Conference (NAECON)*.
- Endsley, M.R. (1988b). Design and Evaluation for Situation Awareness Enhancement, *Proceedings of the 32nd Annual Meeting of the Human Factors Society*, 1, 97-101.
- Fisher, D.L. (1993). Optimal Performance Engineering: Good, Better, Best. *Human Factors*, 35(1), 115-139.
- Fracker, M.L. (1988). A Theory of Situation Assessment: Implications for Measuring Situation Awareness. *Proceedings of the Human Factors Society 32nd Annual Meeting*.
- Good, M.C. and Baxter, G.L. (1986). Evaluation of Short-Range Roadway Delineation. *Human Factors*, 28(6), 645-660.
- Green, D.M. and Swets, J.A. (1966). *Signal Detection Theory and Psychophysics*, New York: Wiley.
- Hancock, P.A. and Warm, J.S. (1989). A Dynamic Model of Stress and Sustained Attention. *Human Factors*, 31(5), 519-537.
- Hellier, E.J. et al. (1993). Improving Auditory Warning Design: Quantifying and Predicting the Effects of Different Warning Parameters on Perceived Urgency. *Human Factors*, 35(4), 693-706.

Hendy, K.C. et al. (1993). Measuring Subjective Workload: When Is One Scale Better Than Many? *Human Factors*, 35(4), 579-601.

Hill, S.G. et al. (1992). Comparison of Four Subjective Workload Rating Scales. *Human Factors*, 34(4), 429-439.

Hollister, W.M. (ed.). (1986). *Improved Guidance and Control Automation at the Man-Machine Interface*, AGARD Advisory Report No. 228.

Jex, H.R. and Allen, R.W. (1974). Evaluating Biodynamic Interference with Operation Crews, presented at "Vibration and Combined Stresses in Advance Systems," AGARD Aerospace Medical Panel Specialists Meeting, Oslo, Norway, Systems Technology Inc. Technical Paper 153A, Hawthorne, CA.

Jex, H.R. et al. (1982). Comprehensive Measurement of Ride of In-Service Trucks, SAE Paper 810045, Society of Automotive Engineers, Warrendale, PA.

Kantowitz, B.H. and Sorkin, R.D. (1983). *Human Factors: Understanding People-System Relationships*, John Wiley & Sons, New York.

Krendel, E.S. et al. (1988). *Pilot Risk Assessment of Windshear Hazards*, Systems Technology, Inc. Technical Report No. 1246-1, NASA Contract NAS2-1250.

Kirlik, A. (1993). Modeling Strategic Behavior in Human-Automation Interaction: Why an "Aid" Can (and Should) Go Unused. *Human Factors*, 35(2), 221-242.

Koelega et al. (1989). Processing Demands, Effort and Individual Differences in Four Different Vigilance Tasks. *Human Factors*, 31(1) 45-62.

Louwerens, J.W., Brookhuis, K.A. and O'Hanlon, J.F. (1986) Several Antidepressants' Acute Effects upon Actual Driving Performance and Subjective Mental Activation, in O'Hanlon, J.F. and de Gier, J.J. (eds.), *Drugs and Driving*, Taylor & Francis, Philadelphia: 203-212.

Mackie, R.R. (1977). *Vigilance: Theory, Operational Performance and Physiological Correlates*, New York: Plenum.

Mackie, R.R. (1987). Vigilance Research - Are We Ready for Countermeasures. *Human Factors*, 29(6), 707-723.

McRuer, D.T. (1980). Human Dynamics in Man-Machine Systems, *Automatica*, 16(3), 237-253.

- McRuer, D.T. and Klein, R.H. (1976). Effects of Automobile Steering Characteristics on Driver/Vehicle Performance for Regulation Tasks, SAE Paper 760778, Society of Automotive Engineers, Warrendale, PA.
- McRuer, D.T. et al. (1985). *Decision Making Modeling for a Theory of Human Error*, Systems Technology, Inc., Technical Report No. 1225-1, NASA Contract NAS2-12094.
- Meister, D. and Enderwick, T.P. (Eds.). (1992). Special Issue: Measurement in Human Factors. *Human Factors*, 34(4), 384-501.
- Morrison, R. (1994). *Automated Performance Measurement System: Technical Summary and Workshop Synopsis*, NASA and FAA Aviation Safety Reporting System, Mountain View, CA.
- NASA. (1989). *Man-Systems Integration Standards*. NASA-STD-3000, Revision A. National Aeronautics and Space Administration.
- Nagel, D.C. (1988). Human Error in Aviation Operations, in Wiener, E. and Nagel, D.C. (eds.). *Human Factors in Aviation*, Academic Press, New York.
- National Plan for Aviation Human Factors*, (1990), US Dept. of Transportation, Federal Aviation Administration.
- O'Hanlon, J.F. et al. (1986). Performance Testing as Part of Drug Registration, in O'Hanlon, J.F. and de Gier, J.J., (eds.), *Drugs and Driving*, Taylor and Francis, Philadelphia, 311-330.
- Olson, P.L. and Sivak, M. (1986). Perception-Response Time to Unexpected Roadway Hazards. *Human Factors*, 28(1), 91-96.
- Parasuraman, R. (1987). Human-Computer Monitoring. *Human Factors*, 29(6), 695-706.
- Pew, R.W. (1994). Situation Awareness: The Buzzword of the '90s. *Cyberic Gateway*. V(1), 1-4, Crew System Ergonomics Information Analysis Center, Wright-Patterson Air Force Base, OH.
- Rosekind, M.R. et al. (1994). Fatigue in Operational Settings: Examples from the Aviation Environment. *Human Factors*, 34(2), 327-338.
- Sanquist, T.F. et al. (1993). *Human Factors Plan for Maritime Safety*, Report No. CG-D-11-93, US Coast Guard Office of Engineering, Logistics, and Development, Washington, DC.
- Sheridan, T.B. (1994). Safety and Human Factors in IVHS. *IVHS Review*, Winter/Spring 1994, Intelligent Vehicle-Highway Society of America, Washington, DC.

Sheridan, T.B. and Ferrell, W.R. (1974). *Man-Machine Systems: Information, Control, and Decision Models of Human Performance*, The MIT Press, Cambridge, MA.

Smiley, A. et al. (1980). Changes in Driver Steering Control with Learning. *Human Factors*, 22, 401-415.

Smiley, A. (1986). Assessment of Drug Effects on Driving Performance Using On-the-Road Studies. In O'Hanlon, J.J. and de Gier, J.J. (eds.), *Drugs and Driving*, Taylor & Francis, Philadelphia, 51-68.

Stokes, A. et al. (1990). *Display Technology: Human Factors Concepts*, Society of Automotive Engineers, Inc., Warrendale, PA.

Transportation Research Board. (1994). *Driver Performance Data Book Update*, Transportation Research Circular 419, National Research Council.

Triggs, T.J. et al. (1991). *Prospectus on Multi-Modal Aspects of Human Factors in Transportation*, prepared for Research and Special Programs Administration, Volpe National Transportation Systems Center, Cambridge, MA.

Wickens, C.D. (1989). Resource Management and Time-Sharing. in Elkind et al. (eds.) *Human Performance Models for Computer-Aided Engineering*, National Academy Press, Washington, DC.

Wiener, E.L. and Currie, R.E. (1980). Flight-deck Automation: Promises and Problems. *Ergonomics*, 23, 995-1011.

Wierwille, W.W. and Eggemeier, F.T. (1993). Recommendations for Mental Workload Measurement in a Test and Evaluation Environment. *Human Factors*, 35(2), 263-281.

Wilson, J.R. and Rutherford, A. (1986). Mental Models: Theory and Application in Human Factors. *Human Factors*, 31(6), 617-634.

*Windshear Training Aid, Vols. 1 & 2*, (1987). Associate Administrator for Development and Logistics, Federal Aviation Administration, US Dept. of Trans., Washington, DC.

# Interpretation of Operator Performance Data

*--Alison Smiley, PH.D., Human Factors North*

## INTRODUCTION

Pilots, mariners, engineers, and drivers are all human operators sharing the same abilities and limits. In every mode their tasks involve navigation, guidance, that is, interaction with other aircraft, ships, trains or vehicles, and control. Surely there are similarities here which provide an opportunity for the cross-modal use of performance data. The intent of this paper is not to delineate specific areas where these opportunities exist. That is the task of the workshop, where expertise from every mode will be represented. The intent of this paper is rather to consider the extent to which it will be possible to make such generalizations, given the differences between modes in operator, task, and operational characteristics.

This workshop provides a welcome occasion to discuss operator performance with colleagues from all modes. It is instructive to consider why such a workshop is so rare. Why do we tend to narrowly focus on a single mode? Let me offer an anecdote as a response.

Some years ago I was privileged to be the human factors expert witness at the Royal Commission of Inquiry into the Hinton Train Collision, a major crash in which 23 people were killed. I well remember the lawyers' questions about my experience with trains. How many hours had I actually ridden in the locomotive? What did I know about signal lights or engine brakes? How could I possibly think I had any insight into an engineer's performance? Lawyers are good at articulating what everyone thinks but dares not say.

The judge for the Inquiry talked at length in his report about the railway culture and its resistance to ideas from the outside. I would say that all modes suffer from this and there is some justification. Pilots operate in three dimensions, drivers and mariners in two, and train operators in one. The inputs, outputs and vehicle dynamics vary radically from one mode to another and from one type of aircraft, ship, truck, etc. to another. Operator training and skill levels, safety culture and motivation differ. Tables 3 and 4 show some of the major differences between modes in operator and task characteristics. (Due to space considerations, the tables only refer to the operators of vehicles. All modes also involve dispatchers, controllers and regulators, whose performance is equally important for safe operation.) These differing characteristics can have profound effects on performance.

Because of these differences, staying within our own mode - our own culture - is safe and familiar. Travel into other modes, like travel into other cultures, is risky. While we may have much to offer our colleagues, we may be ignorant about significant factors affecting operator performance in other modes. An approach which respects the modal culture of others will be rewarding. Like travel to other cultures, we stand to gain insights we would never have had by staying home.

**Table 3. Operator Characteristics**

**ROAD:**

**Age:** 16 minimum, no maximum  
**Gender:** Equal numbers of males and females  
**Visual Acuity:** Minimum 20/40 in one eye, not checked regularly  
**Training:** No minimum  
**Medicals:** Private: none required, serious impairments possible (e.g., paraplegia, deafness, brain injury, etc.)  
Professional: may be required  
**Recertification:** Infrequent, if at all  
Age and/or medical condition dependent

**RAIL:**

**Age:** Early 20's - 65  
**Gender:** Predominantly men  
**Visual Acuity:** Minimum 20/30 in each eye, normal color vision  
**Training:** Professionally trained, months, site specific  
**Medicals:** Every 1-2 years  
**Recertification:** None

**AVIATION:**

**Age:** 17 years (private), 18 years (commercial) minimum  
**Gender:** Predominantly men  
**Visual Acuity:** 20/30 in each eye minimum  
**Medicals:** Private: Under 40 - every 2 years  
Over 40 - every year  
Commercial: Under 40, every year  
Over 40, every 6 months  
**Training:** Private - 45 hours minimum  
Commercial - 200 hours minimum, aircraft specific  
**Recertification:** Commercial - every 6 - 12 months  
Private - none

**MARINE:**

**Age:** No minimum (private), 16 minimum (commercial)  
**Gender:** Predominantly men (commercial)  
**Visual Acuity:** 20/20 correctable each eye, color vision (commercial), private - no minimums  
**Medicals:** Every 1 - 3 years (commercial), private - none  
**Training:** Private - none  
Commercial - 9 months sea service  
**Recertification:** None

**Table 4. Task Characteristics**

**ROAD:**

|                       |                                                                                                                                                                                                                          |
|-----------------------|--------------------------------------------------------------------------------------------------------------------------------------------------------------------------------------------------------------------------|
| <b>Navigation:</b>    | Uses signs, landmarks, and maps                                                                                                                                                                                          |
| <b>Guidance:</b>      | Maintaining separation from other traffic requires continual attention by operator, typically involves frequent stops and starts, currently no collision avoidance systems                                               |
| <b>Control:</b>       | 2-dimensional control, using steering wheel, accelerator and brake, operated by hand and foot, only automated speed control available, road scene sampled frequently (every 2 seconds), instruments sampled infrequently |
| <b>Communication:</b> | By eye contact, turn signals, horn                                                                                                                                                                                       |
| <b>Crew Size:</b>     | 1                                                                                                                                                                                                                        |

**RAIL:**

|                       |                                                                                                                                                                                                                      |
|-----------------------|----------------------------------------------------------------------------------------------------------------------------------------------------------------------------------------------------------------------|
| <b>Navigation:</b>    | Uses signals (external, in-cab)                                                                                                                                                                                      |
| <b>Guidance:</b>      | Separation from other trains controlled by dispatcher                                                                                                                                                                |
| <b>Control:</b>       | 1-dimensional control, using throttle, and brake, operated by hand, fully automated control being developed, not yet available High workload during start-up, braking and difficult terrain; Low workload during run |
| <b>Communication:</b> | By radio                                                                                                                                                                                                             |
| <b>Crew Size:</b>     | 2 (in cab)                                                                                                                                                                                                           |

**MARINE:**

|                       |                                                                                                                                                                                                                                                               |
|-----------------------|---------------------------------------------------------------------------------------------------------------------------------------------------------------------------------------------------------------------------------------------------------------|
| <b>Navigation:</b>    | Uses buoys, land lights, charts, radar, GPS, Loran                                                                                                                                                                                                            |
| <b>Guidance:</b>      | Separation from other ships maintained through radar and visual checks and assistance from marine traffic regulators                                                                                                                                          |
| <b>Control:</b>       | 2-dimensional control, using wheel, rudder, propeller angle, automated control for maintaining position available, view ahead sampled several times a minute, instruments sampled with similar frequency, high workload in harbour areas, and in poor weather |
| <b>Communication:</b> | By radio                                                                                                                                                                                                                                                      |
| <b>Crew Size:</b>     | 2 - 6 (on bridge)                                                                                                                                                                                                                                             |

**AVIATION:**

|                       |                                                                                                                                                                                                                                                                       |
|-----------------------|-----------------------------------------------------------------------------------------------------------------------------------------------------------------------------------------------------------------------------------------------------------------------|
| <b>Navigation:</b>    | Uses gyro-compass, charts, landing lights, GPS, Loran                                                                                                                                                                                                                 |
| <b>Guidance:</b>      | Separation from other aircraft maintained by dispatchers, and aided by collision-avoidance systems                                                                                                                                                                    |
| <b>Control:</b>       | 3-dimensional, using joystick, rudder, ailerons, fully automated control available, low visual demand from outside view except on takeoff, landing and taxiing; high visual demand from instruments; high workload at takeoff and landing; low workload during flight |
| <b>Communication:</b> | By radio                                                                                                                                                                                                                                                              |
| <b>Crew Size:</b>     | 1 - 3                                                                                                                                                                                                                                                                 |

We collect human performance data not just for its own sake but because we want to apply it to real-world settings. We design experiments to measure perception reaction time so that we can better predict stopping sight distance and appropriate curve radii for roads. We measure eye glance duration for new displays to ensure they are effective and safe for use in cockpits. We collect data on fatigue and watchkeeping so we can put in place regulations on safe manning hours for ship crews. Applying this data to the real world is not simple. It requires an understanding of the complexities of human performance, the variation from young to old, from skilled to unskilled, alerted to unalerted, and the impact of differing motivations. Applying the data across modes requires an understanding of the subtleties of the operator's task and the impact of the operational environment on tasks in each mode.

This paper addresses the cross-modal use of performance data in the following three sections. The first concerns the generalizability of raw performance data, such as data on mean perception-reaction time in an emergency situation, mean glance duration time to adjust a control and so on. The second section concerns the generalizability of experimental findings about general patterns of human behavior. The third and fourth sections concern the use of raw data and experimental findings in the setting of the operational guidelines and in making of design decisions. In each section I will explore some of the limits of applying performance data to the real world within a single mode, and then inter-modally. Because my own work has been predominantly in on-road transportation, most of my examples will be drawn from this area. However, as will be seen, the issues raised are cross-modal.

## **INTERMODAL USE OF RAW DATA**

If the performance of humans could be measured like that of non-life forms, the use of performance data would be straightforward. For physical entities, characteristics such as dielectric constant, specific gravity, etc. can be established once and for all and relied on to be constant from one setting to another. It would make life simpler, although less interesting, if human perception-reaction time, eye glance duration, etc. were similarly immutable qualities. Obviously, this is not the case. The hallmark of the human operator is adaptability. While this is our most valuable asset in system operation, at the same time it means performance varies from one setting to another, from one operator to another, and over time for a given operator. Before even contemplating applying performance data gathered in one mode to another, we need to consider the factors affecting performance measurements within a single mode.

### **Task Characteristics**

One of the most powerful factors determining performance is the exact nature of the task at hand. As an example, let us consider the task of looking in a rear view mirror while driving. If subjects are instructed to check the left rear view mirror to see if there is a vehicle behind them the mean time taken away from the road for a glance is 1.1 seconds. If they are asked to check the mirror to determine the color of the car behind them the time taken extends to 1.3 seconds (Rockwell, 1988).



The type of mirror, whether left or right, planar or convex, also affects glance duration. Burger et al. (1974) using data collected in actual traffic for left mirror glances during lane changes found 1.15 seconds glance durations for planar mirrors and 0.875 seconds for a convex mirror. Even though the task is superficially the same - looking at vehicles in the rear view mirror - the information processing requirements and the devices used mean that these tasks differ in difficulty. Even subtle differences result in significant changes in eye glance duration.

What happens to these values if the task is the same, that is checking to see if a pass can be made, but a truck, rather than a car, is involved. Here the glance duration time for planar left mirrors lengthens from an average of 1.15 seconds in a car to 1.37 seconds in a truck. It is the same task, but a truck cannot respond as rapidly as a car, vehicles further back present more of a problem to a truck driver than to a car driver. The further back the vehicle, the slower the rate of angular change, and the more difficult it is to determine the speed of closure of gap. Again, subtle differences in the task increase the information processing requirements, and glance duration time changes.

The visual search requirements are very different when one moves from one mode to another. While in motion on the road, drivers must check the road surface approximately every 2 or 3 seconds in order to maintain lane position. This means eye glances at the road are short - as little as 1/3 seconds in length - and visual tasks like reading in vehicle displays frequently require more than one glance. Drivers can make up to 200 glances per minute while moving.

Watchkeepers on ships have very different visual search patterns. One study found that, when there is a single watchkeeper on the bridge, only 4 observations outside are made per minute (Donderi and Ostry, 1986).

Drivers are solely responsible for visual search. In contrast, there may be as many as 6 persons responsible for visual search or lookout on a ship bridge. As the number of watchkeepers increases, the total number of looks increases, but not in a linear manner. With pilots and mariners, most of the high demand visual search occurs at the beginning and end of journeys (takeoff, landing, leaving harbor and docking). For drivers, visual demand remains high throughout the journey.

Pilots and mariners must spend far more time looking at instruments inside the moving aircraft or ship than is the case for the driver of a car. Train engineers, on the other hand, spend little time looking at instruments because they mainly change in response to control actions which are infrequent.

Not only do modes differ in how visual search is accomplished, they also differ in how psychomotor control and decision making tasks are performed. Task differences between modes do not mean data are never transferable from one to another, only that the circumstances must be closely equivalent to do so. I recently had to estimate the time it would take for a recreational boater to respond with a steering movement to the presence of an unanticipated sailboat. No

such data were available for boaters. However, it was possible to make a very satisfactory approximation using data from a similar situation - the response time of drivers to unexpected objects on the road.

## **Operator Characteristics**

The characteristics of the operator are just as important as the characteristics of the task in determining actual data values. Operators differ in many ways: age, gender and level of experience being the most obvious and also most likely to be identified and controlled for.

### **Age**

With the aging of the population in the developed world, the effects of age on performance have become increasingly of interest. There are a multitude of studies showing changes such as decreases in information processing rate, slowing of response time, etc. One of the interesting patterns in this research has been the finding that with increased age there is increased variability in performance. Some older operators will perform as well as or better than younger operators, making age-based guidelines discriminatory. Another interesting aspect of this research is that, although we generally acknowledge the positive effect of age in increasing wisdom, we never seem to be able to find any positive effects of age in performance studies. Perhaps the problem related to considering details of behavior in isolation, rather than looking at overall strategies that are adopted.

Whether or not data collected in experimental studies of older, non-professional operators is representative is very questionable. This is particularly problematic in studies of car drivers where the age span is so large. Staplin et al. (1989) recruited 65 to 80 year old drivers for a visual performance study related to traffic signs and lane markings. One group was recruited using newspaper ads and presentations to community groups. These subjects came to a laboratory for testing. A second group of 65 to 80 year olds was recruited at photo license centers and asked only to complete a brief test of contrast sensitivity while at the center.

Contrast threshold levels for the older drivers who volunteered for laboratory testing were 5 times better than those for the more representative group of older drivers recruited at the driver license centers. This has major implications for contrast requirements for traffic control devices that will meet the needs of older drivers. It underscores the importance of calibrating laboratory data with real-world data.

The various transportation modes differ greatly in the age range of operators that need to be considered. Older professional operators: all train crews, all commercial pilots, most professional mariners and truck drivers rarely exceed 60 to 65 in age. In contrast, amongst the general driving population, "older operators" means operators well into their 80's. There is likely to be a much wider range of performance amongst recreational operators than amongst professional operators, as a factor of age alone. In addition, the more stringent the assessment of

visual acuity and performance in general, the smaller the differences due to age are likely to be. One would expect a much larger variation in performance of older and younger car drivers than one would expect in the performance of younger and older commercial pilots given the yearly recertification generally required. What constitutes older operator performance in one mode is likely to differ from other modes as a function of retirement ages, as well as ongoing medical and performance certification requirements.

At the other end of the scale, there are differences between modes in what constitutes a younger operator. In recreational boating younger operators can be children 10 years old. In driving 15 or 16 is a minimum. Amongst professional operators in rail, marine, or aviation environments, the young operator will be in his or her twenties.

## **Gender**

Most performance studies in transportation, with the exception of car driving by the general population, involve male subjects. As women become increasingly involved in non-traditional occupations, performance studies based on men only will become less relevant. For example, men and women may use different performance strategies. In studies with a step pursuit tracking device, women were found to attain higher levels of accuracy, men faster rates of speed. In a study of emergency braking, men and women were found to have equivalent stopping distances. Men drive slightly faster but were able to apply greater braking force (Smiley and Rochford, 1991). It should be noted, however, that not all differences attributed to gender are innate. Many are, in fact, differences in experience associated with males and females (e.g., driving experience, characteristics of driving exposure) and not differences due to gender per se.

## **Skill Level**

Operators differ in skill level. There is a large gap in skill between the pilot who flies a few times a year for a hobby and a commercial airline pilot with years of experience. One would expect that highly trained professional operators would perform better than recreational operators. A recent study at the Volpe Center using commercially licensed and general aviation pilots demonstrated this. Information processing capacity for air traffic control instructions (altitude, heading, radio frequency) was examined. The general aviation pilots used in an initial stage of the study were to remember accurately only one piece of information at a time. The commercial pilots were generally able to correctly remember three pieces of information.

While this difference between professionals and non-professionals may be valid in the aviation environment, where selection, training and continual recertification are required for professionals, it is unlikely to be as pronounced with car and truck drivers, for whom training and selection of professionals is far less rigorous. Indeed, there is a great deal of doubt that current driver training or selection is effective. A recent study compared eye patterns of experienced drivers to those taught in driver training courses. What experienced drivers did bore little resemblance to what instructors were teaching novices to do (Zwahlen, 1991). With respect to

selection, scores on driving licensing exams have been found to be almost completely uncorrelated with crash experience following licensing. Thus, although the professional non-professional comparison may be valid in one mode, it will be different in another.

### **Other Operator Characteristics**

Many other innate operator characteristics are important but may not be considered by experimenters. A study of navigational systems selected subjects who were at either extreme in terms of measured map reading and spatial abilities (Verwey and Janssen, 1988). When subjects used a paper map, the low ability group made significantly more errors on the most complex route, especially when the traffic density was high. While many subject characteristics affect performance; generally only a few can be controlled for.

Spatial abilities, and other characteristics of professional operator populations may differ significantly from those of the general population. To the extent that these populations differ in such characteristics, raw data obtained from one group may not be applicable to another. In addition, professional operators in one mode may have been selected on the basis of different abilities than professional operators in another mode.

### **Alertness**

It is obvious that age, gender, and skill level at a minimum should be considered in generalizing performance data from the laboratory to the real world and from one mode to another. We are all aware of the drawbacks of applying data from young males, especially when the sample is limited to university students or military personnel, to the population at large. However, there are other more subtle operator characteristics which can have an even more pronounced impact on performance. These arise out of what may be called the Heisenberg Uncertainty Problem - the act of overtly observing behavior changes it. Operators in experiments are alerted and motivated differently than those in the real world. If we are to apply experimental data to the real world, the impact of operator alertness and motivation must be considered.

If operators were alerted every time they were about to have a collision, most collisions could be avoided. A study in France analyzed collisions to determine which high-technology device would have been most effective in avoiding them. The answer was a low alertness warning device. In experiments, it is difficult for a subject to relax and enter an unalerted state. There is usually a researcher sitting beside him or her ready to pounce on a second brake in event of an emergency. A mass of measuring devices is usually in evidence, and the subject may even be wired for data collection.

There are two methods that have been used to circumvent this problem. One is to deceive the subjects as to the true purpose of the experiment. The other is to measure behavior of operators who are unaware they are being observed.

An example of the first approach is a study by Roper and Howard (1938). Subjects were told that the experiment was about seeing distance with various types of headlights. After the trials were completed in the test area, the researcher indicated to the subject that the experiment was over and he should drive back to the laboratory. On the return drive, when the subject presumably had relaxed his guard, having completed the tests, he suddenly encountered a pedestrian target. The car was instrumented so that the distance at which the subject responded to this unexpected target could be recorded. Once the driver knew exactly where the target was and what it looked like, he then backed the car up and drove forward at the same speed as previously until he could just see the target and stopped again. On average, seeing distances when the target was unexpected were 50% of those obtained when the driver knew where to look. This calibration factor linking experimental and real-world performance has been used in countless legal cases.

An example of the second approach to measuring unalerted behavior is a study by Triggs and Harris (1982) of driver response time. Perception-reaction time were recorded by drivers to brake in response to the presence of a speed radar, a car parked at the side of the road with the tire being changed, railway crossing signals being initiated and so on. Reaction times recorded tended to be longer than those measured in experiments. Clearly, state of alertness is a major factor. However, the required safety of the experimental situation meant that none of the situations observed was a real emergency. This is likely to lengthen reaction times compared to those for true emergencies. This is a common problem in observational studies. It is one of the limits we face in being able to estimate operator's likely responses to real-world emergencies.

## **Motivation**

In an experiment, the subject is generally aware of being observed and having his or her behavior measured. This tends to affect motivation. Whether or not the experimenter has a standard of good performance, the subject feels that she does. I have often been asked during studies of driver behavior to give the driver her score. It is hard to convince subjects that you want them to behave as they normally would and are not judging them as you might in an exam situation. This sense of being rated inevitably leads to subjects being more attentive and compliant with the rules of the road than they might on their own.

The effect of motivation must be considered if performance data are to be used to predict the impact of new regulations or technology. Regulations will be ineffective if they are not obeyed. Technology to improve safety will be ineffective if operators use it to improve mobility instead. In highway safety, new traffic control devices are frequently developed with the hope of improving driver behavior. A study by Luoma (1992) looked at 3 signs intended to slow drivers down. The study compared responses of drivers who knew they were being observed with those of drivers who were unaware. One group of drivers was outfitted with eye marker cameras and their speeds measured as they passed the various signs. Speed before and after reaching the signs was also recorded for drivers who were unaware they were being observed. Whether drivers knew their behavior was being measured or not, only the speed limit sign resulted in a significant

slowing. Although the two groups of drivers responded similarly to the signs, the size of the speed reduction to the speed limit sign was much greater for the aware as compared to the unaware drivers. Thus, raw data from an experiment using aware subjects is likely to overestimate the efficacy of a safety intervention.

The lesser compliance of real-world operators to signs is also evident in measures of speed and stopping behavior. Subjects in on-road and simulator experiments generally come to a full stop at stop signs - only 30% of stops made in the real world meet this standard. Similarly, experimental subjects will keep close to the speed limit, whereas studies of drivers unaware of being observed show that the majority exceed the speed limit, and a large number of them by more than 2-3 mph generally observed in experimental studies. Only 57% of drivers on roads signal turns (Ohio State University, 1964); observed subjects are likely to be more conscientious. This should not be taken to mean that simulator studies are invalid. Far from it - as will be discussed in a later section, the nature of changes found due to alcohol and drugs in simulators are duplicated in real-world studies - it is the size of the effect that will differ.

There are many reasons for this inconsistency between experimental and real-world behavior. For example, in experiments, there is no need to rush. In the real world, operators are often under pressure to meet delivery schedules, or to get to work, appointments or social events on time. In experiments, subjects are aware of being observed. In the real world, they can operate more anonymously. The consequence is less compliance with operating rules.

Usually experiments are short, and it is not difficult for subjects to sustain “best behavior” as opposed to normal behavior. In real life they will bend the rules if tired or in a hurry or if trying to impress others - the motor boat operator who cuts in front of the yacht, the pilot who rhymes off the checklist without looking at the instruments he is supposed to be checking, the driver who runs the red light.

It should be noted that there are strong parallels between experimental situations and “fitness for duty” testing. The latter is also a situation where an operator is highly alerted and motivated - being able to work depends on the results of the test. The test is short, and the operator will only need to sustain good behavior for a limited period.

This difference between observed and unobserved performance in compliance is likely to be less with professional operators, especially where the organizational environment supports a strong safety culture. One would expect less difference between the actions of a commercial airline pilot in an experiment and in the real world, than one might expect for a recreational boater in similar situations. Operating in a strong safety culture is equivalent to being aware of being observed.

The difference between the performance of operators who are aware their performance is being measured and those who are not, will also depend on the operational situation. The greater the sense of a hierarchy in the crew, the more similar measured and unmeasured performance is

likely to be. The presence of a captain is again equivalent to being aware of being observed by an experimenter.

## **Behavioral Adaptation**

Related to motivation are long-term changes in behavior known variously as behavioral adaptation or risk compensation. This is not the same as the now discredited idea of risk homeostasis, the theory that human operators maintain a given level of risk, so that the effect of any safety intervention is nullified. In an extensive report on this issue the OECD (1989) defines behavioral adaptation as “those behaviors which may occur following the introduction of changes...which are not consistent with the initial purpose of the change.” Human operators have a penchant for trading safety benefits for mobility benefits. This proclivity must be recognized if we are to predict real-world operator performance from experimental data.

Let us explore a few examples of this behavioral adaptation. Increasing shoulder width and improving shoulder type are intended to improve safety. Both interventions are associated with increases in driving speed (Leong, 1968; Fambro, Turner, and Rogness, 1981), a negative change with respect to safety. Similarly, increasing lane width and providing edge lines are associated with speed increases (Leong, 1968; Transport Canada, 1985). All these interventions are associated with reductions in crash rate, however the increased speeds suggests that the reduction obtained was less that might have been, had drivers not traded off some of the safety benefit for mobility.

High-mounted rear lights were developed to increase the likelihood that drivers would notice them when illuminated. Initial studies using vehicle fleets indicated that we could anticipate reductions of 50% in rear-end crashes where the presence of a high-mounted light could be expected to have an impact. As a result of the research on high-mounted lights, legislation was introduced to make them mandatory in vehicles manufactured after September, 1985. A study a year after the introduction found that the actual decrease in relevant rear-end crashes was 15%, much lower than the 50% anticipated. Studies after this showed continuing declines in effectiveness. What happened? To date, there have not been studies to examine this, but one form of adaptation is likely. If a driver can see through the windows of the car ahead to the car in front of him, he may follow closer to the vehicle in front, given that he has an advance warning of the traffic slowing ahead from the car ahead of the one he is following. However, this closer following will negate some of the benefit of the advance warning. a second likely adaptation is that the high-mounted lights are less attention getting now that many vehicles have them, than was the case initially when only a few were so equipped. Despite a lessor effect than anticipated, there is no reason to despair over the fate of high-mounted lights - 15% is still a major reduction.

Other safety interventions have not been as successful. Initial studies of anti-lock brakes showed they were highly effective - on wet surfaces stopping distances were shortened and steering control was maintained. Later experimental studies where subjects were free to adopt different strategies showed drivers adapted to the presence of the anti-lock brakes so that their safety

benefit was compromised. A study by myself and colleagues showed that drivers with ABS drove just slightly faster than those without ABS with the result that the emergency stopping distances on wet pavements for the two groups were indistinguishable.

Aschenbrenner, Biehl, and Wurm (1988) used the fact that taxi drivers were used to being observed by passengers to carry out a study of the effects of anti-lock brakes on driver behavior. Taxi drivers were unaware that their passengers were researchers. The researchers were blind to which of the taxis were equipped with ABS. Researchers rated the taxi drivers who had anti-lock brakes as tending towards riskier driving than those not so equipped.

In June 1994, the Insurance Institute reported a comparison of the number and amount of claims for vehicles with and without ABS. No differences were found. Much of this lack of effect is no doubt due to the fact that only a limited percent of collisions will be impacted by ABS. However, the behavioral data suggest that a second reason for the lack of effect may be the tendency for drivers to change their strategies in a way which offsets the benefit of ABS.

### **Real World Performance Shaping Factors**

Because the human operator is adaptable, naturalistic observations which reveal factors which shape real-world performance, are critical. They help to show us why and how countermeasures are circumvented. One rather amusing experiment looked at the impact of warnings on behavior. It concerned signs asking pedestrians not to use the most convenient entrance, but to use a nearby entrance because of safety concerns. The further away the alternative entrance, that is the more inconvenient the action called for, and the less obvious the threat, the less likely people were to obey the sign.

Anonymous interviews and reports like NASA's anonymous reporting system ASRS (Aviation Safety Reporting System) allow us to better appreciate real-world performance shaping factors. Such an approach might have avoided the major train crash I spoke of earlier. The railway company involved in the Hinton train crash relied on the deadman's pedal to be released should the engineer fall asleep or become incapacitated in some other way on the job. In the Inquiry following the crash, it became obvious after the testimony of a number of engineers, that the only time the deadman's pedal was held down by a foot was when managers were riding in the cab. Otherwise, lunchboxes, signal staffs, and other handy devices were employed to do the job, entirely circumventing this safety device. The fact that the pedal was placed in such a way that some force and a somewhat awkward posture was required to hold it down during trips lasting 12 hours or more may have contributed to this. Anonymous interviews or an anonymous reporting system related to safety combined with a different attitude to safety would likely have revealed this problem before it contributed to a fatal crash.

Crash avoidance systems aim to assist the human operator but are likely to result in at least some unwanted compensation. The TCAS system, installed on all commercial aircraft crossing U.S. airspace, warns of aircraft within the vicinity, but only those aircraft with transponders installed.



How will pilot detection of aircraft with and without transponders change? Will they be less likely to detect aircraft without transponders than before they had the TCAS aid? This question of a change in strategy will be of equal interest to those studying collision avoidance systems in vehicles. Will drivers become less vigilant about and therefore more vulnerable to collision situations that cannot be detected electronically?

Behavioral compensation is a very real phenomenon. If we want to accurately predict how technology or regulations will modify operator performance, we should think about how the operator might adapt. It is difficult to outsmart the human operator - the human operator is us!

### **Intermodal Use of Raw Data**

Experimental data are fundamental to the understanding of operator performance. However, the nature of the task, and the characteristics of the operator: age, gender, skill level, alertness, and motivation all effect the performance values measured. Over the long term, operators may adapt to safety interventions, changing their strategies. If we are to apply performance data to the real world we must be sure that the subjects in the experiments resemble the operators we are applying the data to in all these factors. In addition, as the study by Staplin and his colleagues illustrates, those who volunteer to have their performance measured in laboratory studies may differ greatly from the population being sampled. If we want to apply data taken from one mode to another, we need to ensure that the task and operator characteristics are similar enough that the use of the data are valid.

### **INTERMODAL USE OF EXPERIMENTAL FINDINGS**

Experimental research with human subjects would be fruitless if there was no relationship between laboratory performance and real-world performance. In the previous section, I have emphasized the difficulty of applying raw data gathered in experiments to real-world operators. In this section I would like to emphasize the positive - the consistency of patterns of behaviors, from laboratory to real world and from one mode to another.

### **Alcohol Effects**

The fullest picture of the effects of a stressor on performance is in the area of alcohol. We have a wealth of experimental and epidemiological data, and thus a strong link between what happens in real-world crashes and what happens to basic skills in the laboratory.

In order to compare real-world and experimental findings, let us examine some of the characteristics of alcohol-involved crashes and compare them to changes in behavior found in experimental studies. Alcohol is associated with single vehicle crashes: about 62% of fatal single vehicle crashes are alcohol involved (the majority of these, 82%, at levels of 0.10% BAC (blood alcohol concentration) or higher; NHTSA, 1987). Alcohol is associated with crashes that occur at high speeds, and with crashes that occur on curves (Perchonok, 1972).

Experimental studies reveal the behavioral underpinnings of collision characteristics. Inattention increases as the level of alcohol increases. Erwin et al. (1987) measured eye movements and eye closures during a vigilance task. Eye blinks (about 250 msec) and prolonged lid closures (greater than 1 second) were recorded and related to missed signals. As alcohol level increased, the principle change was a dose related increase in the number of missed signals, caused by an increase in the number of brief periods of eye closures. At the highest level of alcohol, misses associated with open eyes increased much more noticeably. Studies of eye movements in such tasks makes sense of the deterioration in tracking which is found from low BAC's up. This deterioration is found in all types of tracking tasks (compensatory, pursuit, critical and sub-critical) and is more pronounced when the tracking tasks are carried out in a divided attention situation, like driving.

The results of eye movement and simple laboratory studies of tracking show that alcohol leads to attentional deficits. These findings explain the epidemiological data showing that a high proportion of single-vehicle crashes is alcohol involved, typically with very high BAC's.

Alcohol-related collisions in the real world are associated with high speeds. There have been three on-road studies of alcohol effects in which speed was significantly affected, in all cases speed was increased (Casswell, 1977; Biasotti et al., 1985; Smiley et al., 1987).

Curves are over-represented in alcohol-involved crashes. In three out of three studies which used slalom courses to examine the effects of alcohol, significant tracking deficits due to alcohol were found (Klonoff, 1974; Hansteen et al., 1976; and Biasotti et al., 1985). In addition, a simulator study using an interactive driving simulator showed that of four tracking tasks, one where alcohol had the greatest effect was on curve-following (Smiley et al., 1985). In addition, another on-road study showed that the increase in speed seen due to alcohol was more significant on curves than the increase found on a straight road (Smiley et al., 1987).

In summary, there is a good correspondence between the characteristics of alcohol-involved crashes in the real world and alcohol effects on driving found in experimental studies. Alcohol is consistently associated with poorer tracking, decreased target detections and slowed response whether performance is measured with laboratory tasks of basic driving skills, simulators or actual vehicles.

Alcohol effects in these studies are also consistently found to be dose related. This is demonstrated in increasing tracking error, eye-glance durations, target misses, response times, etc. as dose level increases. This, in turn, is consistent with Borkenstein's (1964) famous study of crash risk and BAC level. Borkenstein and his colleagues compared the BAC levels of drivers involved in fatal crashes, with those of drivers of the same sex and age range driving at the same time of day and day of the week as the crash-involved drivers. Relative crash risk is set at a value of 1 for sober drivers. Crash risk rises above 1 around 0.05% BAC and starts increasing precipitously above 0.08% to 0.10% BAC.

Further, the correspondence is demonstrated in the ease of obtaining significant effects at each alcohol level. It is the rare experiment which cannot demonstrate an effect at 0.07 - 0.08% BAC. However, sensitive experimental designs are required to demonstrate effects at very low BAC levels - 0.02 to 0.03%.

Studies of drugs other than alcohol also find correspondence in the nature of changes observed in on-road studies and those observed in driving simulators and laboratory studies of driving-related skills. For example, marijuana has been found to impair performance, but in a very different way as compared to alcohol. It is associated with increasing the gap in car following situations, decreasing speed, increasing response time to a subsidiary task, and decreasing numbers of passes. These changes are similar in character whether the data are collected in a simulator, in closed-course on-road studies, or in normal traffic.

Alcohol is known to impair performance in surface, air, and marine transportation. Its effects have been documented in great detail in on-road studies. It is known to be associated with 50% of drownings in recreational boating accidents, and 10% of civil aviation fatalities. It has been shown to impair pilot performance at low levels (Billings, Wick, Gerke, and Chase, 1973). There are no studies, to my knowledge, of the effects of alcohol on train or marine operators' performance. However, since laboratory studies clearly demonstrate that basic skills of visual search, choice reaction time and tracking are affected, it is certain that performance of train and marine operators would be affected.

### **Fatigue Effects**

Fatigue is another stressor which has attracted the attention of researchers. It is much more difficult to quantify than blood alcohol level. By fatigue we might mean any number of things: unwanted changes in task performance, or lowered state of alertness as indicated by physiological measures, probes of response time or subjective ratings. Fatigue arises from a multitude of sources, including circadian rhythm effects, hours worked, task monotony, sleep deprivation, and drug and alcohol effects.

If we examine one of these sources: circadian rhythm effects, we see a consistent effect of time of day on vigilance tasks. Whether the task is detecting radar signals, answering phones, or reading meters, performance levels are found to be worst in the 3 to 6 am period, with a secondary lull in performance just after lunch. These effects have been found in the laboratory and in real-world tasks. They have been found in all modes. A recent paper entitled, "What do subway workers, truck drivers, and pilots have in common?" Fisher (1994, in press) discussed fatigue arising from circadian rhythm disturbance by shiftwork. Though the size of effect may vary greatly from one task and one mode to another, the pattern of the effect is consistent.

Laboratory and real-world studies also show that performance declines with time on task, another contributor to fatigue. In particular, truck drivers show significant increases in lane wandering

after as few as 5 to 6 hours driving. Consistent with this, epidemiological data show increases in crash risk after the same period of time (Harris and Mackie, 1972).

### **Intermodal Use of Research Findings**

In two areas of human performance that have been intensely researched, alcohol and fatigue, the evidence suggests that the kind of changes found in the real world and experimental studies are the same. Furthermore, the impact of stressors, is consistent from one mode to another, patterns of behavior are generalizable to a much greater extent. It can be anticipated, for example, that if ship watchkeepers are more impaired on monotonous tasks than on alerting tasks after extended work periods, the same will be true for engineers and pilots. If valium impairs driving performance, it is likely to impair rail operator performance, and so on.

Some research areas have developed more in one transportation mode than another. While circadian rhythm effects have a longer history of research in aviation and in marine transportation than in surface transportation, their importance in all modes of transportation is increasingly evident. Intermodal sharing of this knowledge has begun to happen at conferences on shiftwork - a meeting devoted to shiftwork in transportation would be timely and beneficial.

Transfer of training from simulators has been well researched in aviation, but much less so with vehicle simulators. As better and less expensive automobile simulators are developed, it is becoming possible to contemplate their use for training, not just specialized groups, but the general driver population. Surface transportation specialists would benefit greatly from the experience of aviation researchers on issues such as transfer of training from simulators to actual vehicles, requirements for part-task simulators, and simulator sickness.

Older operators are of great concern to traffic safety researchers, but less so to those in the aviation world. As the population ages, researchers in the aviation, rail, and marine modes may benefit from insights of traffic safety researchers. Cross modal conferences on specific topics such as hours of service, fitness for duty testing, behavioral adaptation, older operators would allow a fruitful exchange on patterns of behavior as well as methodology. There is already effective borrowing between modes. For example, Mengert, Sussman, and DiSario (1992) applied the Borkenstein's method of assessing crash risk at different BAC's to the recreational boating environment. Stepping outside transportation for a moment, a great deal of work was carried out in the nuclear area on human error models by individuals such as Rasmussen, Reason, and Moray. These concepts are now being used by traffic safety researchers. This borrowing process could be speeded up by deliberately bringing together researchers in different modes on specific topics.

### **OPERATIONAL GUIDELINES**

In the laboratory one tests a hypothesis - does this or that stressor or interface design affect performance related to this or that job, whether it is the ability to correctly plot a course, or to

follow instructions, or to steer a vehicle. In the real world one wants an estimation of risk at different levels of a stressor, whether it is number of hours of flying, number of hours of experience, and so on.

The rubber hits the road, so to speak, when performance data are used as a basis for decisions in work situations or legislation. For example, what should the minimum acceptable score be on a fitness for duty test? How many hours should an engineer be allowed to work before being required to take rest? What is the maximum acceptable BAC level for a recreational boater? At what age should a pilot retire?

Currently, there is little consistency in operational guidelines from one mode to another. Airline pilots are much more limited in the number of working hours per month than is the case for professional mariners, train or truck drivers. There is also little consistency in enforcement of guidelines that exist. No one would tolerate an airline captain flying for 30 hours straight. Yet we tolerate these hours for the first mate on an oil tanker. Legal limits for alcohol are enforced on the roads but rarely on the water, despite the fact that in recreational boating about 50% of drownings are alcohol related. Should limits be the same across modes and should they be enforced more consistently?

Let us first consider how performance data can be used in setting operational guidelines within a single mode. One difficulty in using performance data to set guidelines is that experimental studies often find that the changes due to drugs, fatigue, aging, and so on are small. The question often arises as to when a statistically significant difference is of sufficient practical significance to justify regulations or operational guidelines. Let us again take advantage of the wealth of epidemiological and performance data which provides a continuous link between crash risk and BAC level to examine this issue.

### **Practical Significance of Small Changes**

One on-road study of alcohol effects showed that lane position variability increased from 17 cm. at 0% BAC to 24 cm. at 0.12% BAC (Louwerens, Gloerich, de Vries, Bookhuis and O'Hanlon, 1987). In another on-road study, detection of obstacles by the side of the road was 70.7 m. for subjects at 0.0% BAC and 62.0 m. for subjects at 0.10% BAC, equivalent to 1/2 second difference in response time at the speed travelled (Laurell, McLean, and Kloeden, 1990). Even though these changes were highly significant, they seem rather trivial in magnitude.

We must not forget that real-world changes in absolute crash risk are also very, very small. Hurst's reanalysis (1985) of Borckenstein's Grand Rapids study (Borckenstein et al., 1964) showed that the risk of collision involvement at 0.10% BAC was three times that found at 0% BAC. As BAC level increases, crash risk increases exponentially, at 0.15% BAC it is 10 times that for 0% BAC. This is a serious increase in risk. However, in absolute terms, this means that at 0.10% BAC, one has gone from a risk of about 1 collision in 20 years to 1 collision in 7 years at 0.10% BAC and 1 in 2 years at 0.15% BAC. Looking at this issue another way, it has been estimated

that 1 out of every 800,000 alcohol-related driving trips results in a fatality. Thus, the changes in risk due to alcohol consumption in absolute terms are small. Nonetheless, one must consider the fact that when hundreds of thousands of drivers drive after consuming alcohol, and this driving occurs over periods of weeks and months, this small but increased risk translates to enormous loss of life and thousands of serious injuries every year. Therefore, we should not denigrate the changes found in experimental studies because of their small size. The change in absolute risk is also small, but results, over time, in many injuries and lost lives.

Data on effects of alcohol on crash risk make it clear that small changes in performance cannot be dismissed as meaningless in terms of setting operational guidelines about hours of flying, prescription drugs acceptable for use on the job, fitness for duty pass levels, etc. Nor can small changes in performance be considered trivial in comparing one interface with another, in terms of expected safety.

### **Magnitude of Change and Practical Significance**

Having established the importance of small changes, the next question is what degree of change should determine an operational guideline. For example, if performance measures deteriorate by 50%, is this the point at which the operator should be declared unfit by a fitness for duty test?

One of the problems of determining an appropriate threshold is deciding on which task to base it. Most jobs involve many different tasks. It is usually the case that the magnitudes of change associated with a given level of BAC are task dependent. For example, Moskowitz and Burns (1981) used a divided attention task involving tracking and reaction time to a visual search task, to examine the effects of alcohol at 0.07% BAC. At this level, they found that tracking deteriorated by a factor of 88% from the level at 0.0% BAC, whereas reaction time was only changed by 43%. Such differences in magnitudes of change in different tasks are common.

Within a single task there may be several distinct measures of performance. An auditory signal detection task as used to compare the performance of naval watchkeepers in the 20 - 22 hour period with the 04 - 06 hour period. Detection rate in the early morning hours dropped to 67%, false report rate to 69%, and response speed to 92% of that found in the 20 - 22 hour period. Thus, even within the same task, measures show different rates of change. As exemplified in Table 4, task characteristics differ greatly between modes. It is, thus, likely that there will be a large variation between them in the levels at which impairment becomes evident.

As noted earlier, operators of different ages, training, and motivation differ in performance characteristics. Percent change seen in various tasks will vary according to operator characteristics. Even within a single mode, it is difficult to determine for whom guidelines should be set. Should one consider the average operator, with the risk of allowing older operators to work longer hours than they should? Should one consider the average drinker, with the risk of having too high a limit for inexperienced operators?

Besides subject and task variables, there are also procedural variables to consider. When training is given relative to the test, how many minutes the test lasts, whether subjects are given knowledge of results or not, etc. affect the magnitude of change seen. Thus, the magnitude of change found depends upon the experimental variables. Because the magnitude of change seen at a particular BAC level, or after a certain number of hours flying, depends on the particular experiment, it is difficult to use the magnitude of performance change, on its own, to set operational guidelines.

### **Performance Data and Operational Limits**

Earlier I said that in the real world one wants an estimation of risk at different levels of a stressor, whether it is number of hours of flying, number of hours of experience and so on. Experimental data help to determine how and how much performance is affected by a particular stressor or interface design in comparison to placebo or standard conditions. However, there are no easy answers as to how performance data can be used when it comes to setting operational limits. Data can be interpreted to justify a very wide range of limits.

Not only does performance vary from task to task and subject to subject in experimental studies, it also varies from task to task and subject to subject in the real world. For example, the BAC level of young drivers involved in fatal crashes averages 0.05%, of middle age and older drivers, 0.15%. Epidemiological studies allow the level of risk to be assessed for a representative set of tasks, environments, and operators. To assess level of risk using performance data we would need to test every type of operator, task, and situation and then weight the results according to the exposure of various types of operators, frequencies of tasks and situations. For this reason, epidemiological data, like that collected in the Borkenstein et al. (1964) study must be used if at all possible for the setting of operational guidelines. Performance data tells us what variables are of importance - as well as how performance changes, which is vital in determining appropriate countermeasures. But it is too task, operator, and experimental design specific to be used on its own for setting operational guidelines.

Unfortunately, few stressors can be quantified with the same precision as alcohol, and few stressors have been so clearly associated with risk levels. Even where it is not possible to estimate real-world risk levels, one way of setting operational guidelines for a given stressor is to compare its effects on performance with those of alcohol, for which we know real world risk levels.

For example, physicians are concerned about the effect of sleep apnea on driving and how they can fairly determine which of their patients should continue to drive. Epidemiological studies on the risk of a crash with different degrees of sleep apnea are biased by the fact that having a crash is a frequent reason for drivers to seek treatment for sleep apnea.

On-the-road behavioral studies with sleep apnea patients are problematic for a number of reasons, making a laboratory test situation preferable. However, this then gives rise to the

problem of setting a threshold at which performance is considered unacceptable. One way of anchoring these results is to compare them to results of subjects who are intoxicated at the legal limit (whatever that happens to be). Such a study showed that subjects with sleep apnea were more impaired on driving skills tasks than both sober and legally impaired healthy subjects (Smiley, Leech, and Broughton, 1993). Treatment of the condition improved performance. In absence of unbiased epidemiological data, it would seem reasonable to set a pass level for retaining a driving license at performance equivalent to performance at the legal limit of alcohol. Similarly, drugs have been rated in terms of their effects on driving through comparisons with alcohol.

Several years ago I was a member of a committee charged with deciding at what alcohol level a truck driver's license should be revoked. There were no epidemiological studies of alcohol level and crash risk for truck drivers. To set the level, we depended on the epidemiological data for car drivers and considered the different nature of the truck driving task, the characteristics of truck operators, and the operational environment. The greater complexity of the task, and the exposure to long hours of driving led us to set the limit at 0.04%, significantly lower than the 0.08 to 0.10% levels set for the general population of car drivers (TRB, 1987).

In summary, the best basis for operational guidelines are epidemiological studies of the stressor, operators, tasks, and environments in question. In their absence, we must use related epidemiological and performance data, and make decisions keeping in mind differences in operators, tasks, and environments.

### **Intermodal Consistency in Operational Guidelines**

Given the differences between modes, it is unlikely that crash risk will be similar at the same number of hours of operation, or the same age, or the same level of experience, or the same BAC level in each mode. Nor will our tolerance for crash risk be similar. Where operators are predominantly professionals we tend to set higher standards than for the population at large. Acceptable risk also seems to depend on the mode. The public is much less tolerant of aircraft than of truck crashes. As a consequence, flying is an order of magnitude safer per mile travelled than driving.

Operational differences between modes will also determine standards. Train drivers and truck drivers may suffer the same degree of performance decrement after the same number of hours. However, it is impractical to have train drivers stop between terminals. There are numerous acceptable approaches for reducing fatigue-related decrements besides simply placing an 8-hour limit on work time. Time of day shifts are worked, number of consecutive shifts, length and frequency of rest breaks all impact performance and can be regulated to mitigate against fatigue-related changes in performance.



## DESIGN DECISIONS

Finally, let us consider the use of operator performance data for design decisions. The need for such data was first recognized in the second world war, when poor cockpit interface design led to expensive accidents. Since then, designers and regulators have more and more recognized the contribution of the human element to accidents in all modes. This has led to increased interest in human factors input in design. Areas of current interest include information loading from in-vehicle displays, mental demand associated with various cockpit layouts, efficient bridge design to reduce crew sizes, and automating aspects of train control.

Human performance data can greatly assist in choosing between specific interfaces - which navigational system produces better wayfinding performance and interferes least with vehicle control, which design for a cockpit display produces the fastest response time, etc. It is in this area that raw performance data are most useful. Because the answers sought are relative, i.e. which system is better, it is not critical that data be gathered on unalerted subjects, or in real-world situations. Alerted subjects and simulators, whether full or part task, will provide more than adequate answers to many design questions.

The one caveat is that the performance data used to compare systems should be gathered for the systems of interest using the same subjects, tasks, and environment. Eye glance data gathered for one system in one study should not be compared to eye glance data gathered for another system in a different study unless the subject and task characteristics are very similar. As discussed earlier, the absolute values of raw data are influenced by subject, task, and experimental design considerations.

Because of the cost of collecting performance data, designers may be tempted to try to obtain the required data from human factors design guidelines. This can be a frustrating experience because such guidelines are general and therefore vague when applied to a particular design problem. Setting up an operator performance database will not solve this problem.

First, as any human factors specialist who has been involved in design knows, it is impossible to design an interface that meets every human factors demand. Tradeoffs must always be made. In one situation, it is reaction time that must be optimized, in another as much information as possible must be continuously displayed. Different tasks, different degrees of training of operators, different organizational environments will lead to different tradeoffs and therefore different designs. Determining the optimum tradeoff will require explicit performance testing.

Second, human performance on new systems cannot be predicted except in the most general terms. We know a great deal from basic laboratory studies about such issues as stimulus-response compatibility, the single channel nature of much of human information processing, short term memory capacity, and so on. Such operator performance data were collected without any particular form of transportation in mind and apply across modes. High stimulus-response compatibility will improve reaction time whether in a cockpit or on a ship

bridge. Chunking will increase information processing capacity for air traffic controllers and for truck drivers reading changeable message signs. An understanding of these general patterns of behavior will assist in the initial design of a new human-machine interface. However, this kind of understanding requires human factors expertise in the design process - it cannot simply be gathered from a set of guidelines.

Problems will arise if human factors guidelines are used as a cookbook - controls must be so many inches apart, of so many inches in diameter, etc. Engineers do not design new pieces of equipment according to engineering cookbooks. Rather, they begin with current similar systems and alter them according to new knowledge. Then they thoroughly test them out - the more different the new system from the previous one, the more testing. Just as engineers must test out new aircraft, visual demand created by the layout of its displays etc. in light of the inevitable design tradeoffs which must be made. We can no more predict performance of operators using a new system than can engineers accurately predict system performance (e.g., stall speed or response to contaminants on the wings). Design guidelines based on performance data are just that, guidelines. They cannot be used as specifications.

Using operator performance data intermodally for design decisions is problematic. The tradeoffs that are made on an aircraft cockpit will be different than those made on a ship bridge where space is not at such a premium. They will be different again from those made on a car's instrument panel, where an unobstructed view of the outside environment is critical.

## **SUMMARY**

Raw performance data depends on the operator's task and on the operator's characteristics: age, gender, skill level, training, motivation, and alertness. The experimental design used in measuring the data will affect the values obtained. A given stressor will affect one type of operator more than another, and one task more than another. Professional operators will differ in skill level from the general population. Professional operators are selected for particular abilities, which may well differ between modes. All these considerations limit the usefulness of raw data within a mode, let alone its generalizability to another mode.

On the other hand, the patterns of behavior found in experiments are consistent with those seen in the real world, and they are consistent from mode to mode. These similarities in general patterns of behavior are a valid basis for the modes to share knowledge. Cross-modal interaction will be of particular benefit where knowledge has developed more rapidly in one mode than another, or where modes share common concerns about performance.

One of the major purposes of generating performance data is for the setting of operational guidelines. Raw performance data are too operator, task, and experimental design specific to be used on their own for this purpose. The notion of basing guidelines on such limits as the point at which performance deteriorates by a factor of 50% is too simplistic. On the other hand, patterns of behavior are important in determining issues that should be considered in setting guidelines.

For example, time of day should be considered in guidelines about hours of work. However, performance data alone are insufficient for setting operational limits. Epidemiological data on crash risk which averages out the exposure of various types of operators, and the frequencies and importance of the various tasks are also critical.

Epidemiological data are not always available. If performance data alone must be relied on to set limits, it is important that data gathered in experimental situations be calibrated at some point with real-world data. This is because real-world operators are alerted and motivated differently from operators in experiments. In addition, operators who volunteer for experiments may not be representative in perceptual abilities or in skill.

As to whether or not operational guidelines should be consistent across modes, it is likely that crash risk at a particular number of hours on duty, time of day, level of alcohol, etc. will vary from one mode to another. It will also differ between professional and recreational operators. There are many ways to mitigate a given stressor. What is appropriate in one operational environment will not be appropriate in another. While all modes should consider the same variables in the setting of guidelines (e.g., time of day in hours of work limits), inter-modal consistency in absolute limits (e.g., number of hours, BAC level, required visual acuity) is undesirable.

The second major purpose for which performance data are used is in design. Here raw performance data are valuable in answering questions about which design is best. This is because such questions can be answered with relative data as opposed to the absolute data required in setting operational guidelines. In one design produces better performance with alerted operators, it is also likely to produce better performance with unalerted operators. The size of the effect is likely to be reduced however.

Patterns of behavior determined in laboratory experiments form the basis for design guidelines. Such guidelines are a good starting point for a designer but are no substitute for measurement of operator performance using the designs in question. Just as engineers must test new designs to determine system performance and limits, human factors personnel must test operators to determine whether human limits are exceeded.

All design involves tradeoffs - it is impossible to satisfy all human factors guidelines. The tradeoffs which must be made will differ from mode to mode because the tasks and operating environments are very different.

In conclusion, there is a great deal about patterns of human behavior that researchers and regulators in one mode can learn from those in another. Cross-modal interaction should be encouraged, but only with a great respect for the differences between modes which limit the generalizability of data from one to another.

## REFERENCES

- Aschenbrenner, M., Biehl, B., and Wurm, G. *Mehr Verkehrssicherheit durch bessere Technik? Felduntersuchungen zur Risikokompensation am Beispiel des Antiblockiersystems (ABS)*. Mannheim, Germany. 1988. In Organization for Economic Co-operation and Development. *Behavioural adaptations to changes in the road transport system*. Report prepared by an OECD Scientific Experts Group. 1989.
- Biasotti, A., Reeve, V., Peck, R., Boland, P., and Mallory, C. *Forensic Procedures for the Presence of Marijuana in Blood - Marijuana and Alcohol Performance Study - A Final Report*. (CA/OTS Project 087902). State of California Department of Justice. 1985.
- Billings, C.E., Wick, R.L. Jr., Gerke, R.J., and Chase, R.C. Effects of ethyl alcohol on pilot performance. *Aerospace Medicine*, pp. 379-381. April, 1973.
- Borkenstein, R.F., Crowther, R.F., Shumate, R.P., Zeil, W.B., and Zylman, R. *The role of the drinking driver in traffic accidents*. Bloomington: Indiana University Press. 1964.
- Burger, W.J., Beggs, J.D., Smith, R.L., and Wulfeck, J.W. *Studies in motor vehicle rear vision: Volume II. Evaluation of innovations in passenger car and truck rear view systems*. National Highway Traffic Safety Administration, Report No. DOT-HS-801-258. 1974.
- Casswell, S. Cannabis and alcohol: Effects on closed course driving behaviour. In I. Johnson (Ed.), *Seventh International Conference on Alcohol, Drugs, and Traffic Safety*. Melbourne, Australia. 1977.
- Donderi, D.C., and Ostry, D.J. *Arctic navigation task analysis: Database and modelling*. Report prepared for Transportation Development Centre, Transport Canada. March, 1986.
- Erwin, C.W., Wiener, E.L., Linnoila, M.I., and Truscott, T.R. Alcohol induced drowsiness and vigilance performance. *Journal of Studies on Alcohol*, Vol. 39, No. 3. 1987.
- Fambro, D.B., Turner, D.S., and Rogness, R.O. Operational and safety effects of driving on paved shoulders in Texas. Texas State Department of Highways and Public Transportation and Federal Highway Administration. Report No. FHWA-TX-81/31+265-2F. FHWA. Washington, DC. 1981. In Organization for Economic Co-operation and Development. *Behavioural adaptations to changes in the road transport system*. Report prepared by an OECD Scientific Experts Group. 1989.
- Fischer, F.M. What do subway workers, commercial air pilots and truck drivers have in common? In *Proceedings of International Ergonomics Association 12th Triennial Congress*, Toronto, Canada, August 15-19, 1994.
- Harris, W., and Mackie, R.R. *A study of the relationships among fatigue, hours of service, and safety of operations of truck and bus driving*. Report No. BMCS-RD-71-2 prepared for US DOT, FTA, Bureau of Motor Carrier Safety, Washington, DC. 1972.

Hurst, P. Blood alcohol limits and deterrence: Is there a rational basis for choice? *Alcohol, Drugs, and Driving: Abstracts and Reviews, Vol. 1*, University of California, Los Angeles. 1985.

Klonoff, H. Marijuana and driving in real-life situations. *Science*, 186, 317-324. 1974.

Leong, H.J.W. *Distribution and trend of free speeds on two-lane, two-way rural highways in New South Wales*. Proceedings ARRB, Part 1, pp. 791-814. 1968. In Organization for Economic Co-operation and Development. *Behavioural adaptations to changes in the road transport system*. Report prepared by an OECD Scientific Experts Group. 1989.

Louwerens, J.W., Gloerich, A.B.M., de Vries, G., Brookhuis, K.A., O'Hanlon, J.F. The relationship between drivers' blood alcohol concentration (BAC) and actual driving performance during high speed travel. In P.C. Noordzij (Ed.), *Proceedings of the 10th International Conference on Alcohol, Drugs, and Traffic Safety*. Amsterdam: Elsevier. 1987.

Luoma, J. *Immediate responses to road signs of alerted and unalerted drivers: An evaluation of the validity of eye movement method*. Presented at Transportation Research Board 71st Annual Meeting. January, 1992.

Mengert, P., Sussman, E.D., and DiSario, R. *A study of the relationship between the risk of fatality and blood alcohol concentration of recreational boat operators*. U.S. DOT Report No. CG-D-09-92. May, 1992.

Moskowitz, H., and Burns, M. The effects of alcohol and caffeine, alone and in combination, on skills performance. In L. Goldberg (Ed.), *Alcohol, Drugs, and Traffic Safety*. Stockholm: Almqvist and Wiksell. 1981.

National Highway Traffic Safety Administration. *National accident sampling system 1985: A report on traffic accidents and injuries in the United States*. (NHTSA Publication No. DOT-HS-807-074). Washington, DC: U.S. Department of Transportation. 1987.

Ohio State University (Anonymous). *Investigation of use of turn signals*. 1964.

Organization for Economic Co-operation and Development. *Behavioural adaptations to changes in the road transport system*. Report prepared by an OECD Scientific Experts Group. 1989.

Perchonok, K. *Accident cause analysis*. (CAL Report No. ZM-5010-V-3). Buffalo, NY: Cornell Aeronautical Laboratory, Inc. 1972.

Roper, V.J., and Howard, E.A. Seeing with motorcar headlamps. *Illumination Engineering*, 33, 412-438. 1938.

Smiley, A., Leech, J., and Broughton, R. *Assessment of driving impairment of sleep apnea patients*. Presented at the Colloquium on Vigilance and Transport, Lyon, France. December, 1993.

Smiley, A., and Rochford, S.L. *Behavioural adaptation and anti-lock brake systems*. Final report prepared for Transport Canada, Ottawa. October, 1991.

Smiley, A., Noy, Y.I., and Tostowaryk, W. The effects of marijuana, alone and in combination, on driving an instrumented car. In P.C. Noordzij (Ed.), *Proceedings of the 10th International Conference on Alcohol, Drugs, and Traffic Safety*. Amsterdam: Elsevier. 1987.

Smiley, A., Moskowitz, H., and Ziedman, K. *Effects of Drugs on Driving: Driving Simulator Tests of Secobarbital, Diazepam, Marijuana, and Alcohol*. (DHHS Publication No. ADM85-1386). Washington, DC: U.S. Government Printing Office. 1985.

Staplin, L., Lococo, K., Sim, J., and Drapcho, M. Age differences in a visual information processing capability underlying traffic control device usage. *Transportation Research Record 1244*, pp. 63-72. 1989.

Transportation Research Board, National Research Council. *Zero alcohol and other options: Limits for truck and bus drivers*. Special Report #216. 1987.

Triggs, T.J., and Harris, W.G. *Reaction time of drivers to road stimuli*. Monash University, Human Factors Group, Department of Psychology, Clayton, Victoria, Australia. Report No. HFR-12. June, 1982.

Zwahlen, H.T. Eye scanning rules for drivers - How do they compare with actual observed eye scanning behavior? *Proceedings of the Conference on Strategic Highway Research Program and Traffic Safety on Two Continents* in Gothenburg, Sweden, Part 1. September 18-20, 1991.



**Human Factors Workshop,  
September 20-21, 1994**

Agenda

**Tuesday, September 20** (cont.)

- 1:30 - 2:30           Invited Presentation  
                          “Interpretation of Operator Performance Data”  
                          *Alison Smiley, Human Factors North, Inc.*
- 2:30 - 2:45           Discussion
- 2:45 - 3:00           Coffee Break
- 3:00 - 4:30           Breakout Session II - Issues in Analyzing Operator Performance Data
- Group IIA:     Statistically Significant vs. Meaningful Results:  
                          How “Big” Does A Difference Have To Be Before  
                          It Matters?  
                          *Leader: Marc Mandler*
- Group IIB:     Is Uniform Interpretation of Data Possible?  
                          *Leader: Mark Hofmann*
- Group IIC:     Interpreting Results: How Generalizable Should  
                          They Be?  
                          *Leader: Alexander Landsberg*
- Group IID:     Impact of Differences in Subject Populations On  
                          The Cross-Modal Usefulness of Data  
                          *Leader: Don Sussman*
- Group IIE:     Controlled vs. In-Situ Testing: When Is One More  
                          Appropriate Than Another?  
                          *Leader: Ronald Simmons*
- 4:30 - 6:00           Reception

**Wednesday, September 21**

- 8:30 - 9:00           Reports from Breakout Session I



**Human Factors Workshop,  
September 20-21, 1994**

Agenda

**Wednesday, September 21** (cont.)

- 9:00 - 9:30            Reports from Breakout Session II
- 9:30 - 10:00        Workshop Address  
                          “A Coordinated Vision for Transportation R & D”  
                          *Noah Rifkin, Director of Technology Deployment, Office of the  
                          Secretary*
- 10:00 - 10:15        Coffee Break
- 10:15 - 12:00        Wrap-Up Session  
                          “Perspectives on Cross-Modal Research to Address Operator  
                          Performance”  
                          *Panel Members, DOT Human Factors Coordinating Committee*

ADJOURNMENT

## MEMBERS

### DEPARTMENT OF TRANSPORTATION HUMAN FACTORS COORDINATING COMMITTEE

- NHTSA**      **Robert Clarke, Chair, Human Factors Working Group**  
Chief, Heavy Vehicle and Driver Interaction Research Division, NRD-53,  
National Highway Traffic Safety Administration, Room 6220F, Nassif Building,  
400 Seventh Street, SW, Washington, DC 20590  
(Telephone) 202-366-5664, (Fax) 202-366-7237
- FAA**      **Mark Hofmann**, Chief Scientific and Technical Advisor for Human Factors,  
AAR-100, Federal Aviation Administration, 800 Independence Avenue, SW,  
Washington, DC 20591  
(Telephone) 202-267-7125, (Fax) 202-267-5797
- FHWA**      **Truman M. Mast**, Traffic Safety Division, HSR-30, Office of Safety and Traffic  
Operations Research and Development, Federal Highway Administration,  
Turner-Fairbank Highway Research Center, 6300 Georgetown Pike, McLean, VA  
22101-2296  
(Telephone) 703-285-2404, (Fax) 703-285-2113
- FRA**      **Garold Thomas**, Research Manager, Equipment and Operating Practices  
Research Division, RDV-32, Federal Railroad Administration, Room 5106,  
Nassif Building, 400 Seventh Street, SW, Washington, DC 20590  
(Telephone) 202-366-0468, (Fax) 202-366-7150
- FRA**      **John F. Murphy**, Chief, Special Projects Division, RRP-12, Federal  
Railroad Administration, Room 8302, Nassif Building, 400 Seventh Street,  
SW, Washington, DC 20590  
(Telephone) 202-366-0400, (Fax) 202-366-7688
- FTA**      **Judy Meade**, Drug Program Manager, Office of Technical Assistance  
and Safety, TTS-3, Federal Transit Administration, Room 6432D, Nassif  
Building, 400 Seventh Street, SW, Washington, DC 20590  
(Telephone) 202-366-0188, (Fax) 202-366-3765
- MARAD**      **Alexander Landsberg**, Program Manager, Systems Safety and Human Factors  
Office of Maritime Labor, Training and Safety, Maritime Administration,  
MAR-250, Room 7302, Nassif Building, 400 Seventh Street, SW,  
Washington, DC 20590  
(Telephone) 202-366-1923, (Fax) 202-493-2288

- OST/P      **Robert Nutter**, Chief, Safety Division, P-13, Office of Environment, Energy and Safety, Office of the Assistant Secretary for Policy, Room 9222, Nassif Building, 400 Seventh Street, SW, Washington, DC 20590  
(Telephone) 202-366-2916, (Fax) 202-366-7618
- RSPA      **Norman G. Paulhus**, DRT-1, Office of Research Policy and Technology Sharing, Research and Special Programs Administration, Room 9402, Nassif Building, 400 Seventh Street, SW, Washington, DC 20590  
(Telephone) 202-366-4208, (Fax) 202-366-3272
- USCG      **Marc Mandler**, Chief, Systems Analysis Branch, US Coast Guard Research and Development Center, Avery Point, Groton, CT 06340  
(Telephone) 203-441-2615, (Fax) 203-441-2792
- VNTSC      **Mary D. Stearns**, Operator Performance and Safety Analysis Division, DTS-45, Volpe National Transportation Systems Center, Kendall Square, Cambridge, MA 02142  
(Telephone) 617-494-2617, (Fax) 617-494-3622

#### **AFFILIATES**

- FAA      **Ronald Simmons**, System Technology Division, Research and Development Service, ARD-210, Room 725, Federal Aviation Administration, 800 Independence Avenue, SW, Washington, DC 20590  
(Telephone) 202-267-8529, (Fax) 202-267-5380
- FHWA      **Deborah M. Freund**, Office of Motor Carrier Standards, HCS-10, Federal Highway Administration, Room 3107, Nassif Building, 400 Seventh Street, SW, Washington, DC 20590  
(Telephone) 202-366-5541, (Fax) 202-366-8842
- FHWA      **Robert E.L. Davis**, Office of Motor Carrier Standards, Information Management and Analysis, HIA-20, Federal Highway Administration, Room 3107, Nassif Building, 400 Seventh Street, SW, Washington, DC 20590  
(Telephone) 202-366-2997, (Fax) 202-366-8842
- OST      **Kim Bowen**, Office of Intelligence and Security, S-60, Room 10401, Office of the Secretary, U.S. Department of Transportation, Nassif Building, 400 Seventh Street, SW, Washington, DC 20590  
(Telephone) 202-366-6543, (Fax) 202-366-7261



OPERATOR PERFORMANCE MEASUREMENT: DEVELOPING COMMONALITY

Registration List

Elizabeth Alicandri  
Human Factors Laboratory Manager  
Federal Highway Administration  
6300 Georgetown Pike  
McLean, VA 22101  
(703) 285-2415  
(703) 285-2469

Wade Allen  
Systems Technology, Inc.  
13766 South Hawthorne Blvd.  
Hawthorne, CA 90250  
(310) 679-2281  
(310) 644-3887

Randall E. Bailey  
Principal Engineer  
Flight Research Dept.  
Arvin / Calspan Corporation  
Advanced Technology Center  
P.O. Box 400  
Buffalo, NY 14225  
(716) 631-6939

Gregory Belenky  
Chief, Dept. of Behavioral Biology  
Division of Neuropsychiatry  
Walter Reed Army Institute  
of Research  
Washington, DC 20307-5100  
(301) 427-5521  
(301) 427-5023

Peter Birtwistle  
Chief, Health, Safety and Security  
Railway Safety Directorate  
Surface Group Transport Canada  
344 Slater St, Canada Bldg, Rm 1555  
Ottawa, Ontario K1A0N5  
**CANADA**  
(613) 990-7740  
(613) 957-6254

Deborah A. Boehm-Davis  
Associate Provost for Research/  
Graduate Study  
George Mason University  
4400 University Drive - MSN 3A2  
Fairfax, VA 22030  
(703) 993-8865  
(703) 993-8871

Galen C. Bosley  
Science Research Director  
Total Life Creation, Inc.  
14200 Cantrell Road  
Silver Spring, MD 20905  
301-384-4370  
301-384-4370

Kimberly J. Bowen  
Program Analyst  
Ofc. of Intelligence & Security (S-60)  
USDOT / OST  
400 Seventh Street, SW  
Washington, DC 20590  
(202) 366-6543  
(202) 366-7261

Kim M. Cardosi  
USDOT / Volpe Center, DTS-45  
55 Broadway  
Cambridge, MA 02142  
(617) 494-2696  
(617) 494-3622

Tony Carvalhais  
Human Factors Research Scientist  
USCG R&D Center  
1082 Shennecossett Road  
Groton, CT 06340  
(203) 441-2846  
(203) 441-2792

Sherry Chappell  
Principal Scientist  
NASA Ames  
262-1  
Moffett Field, CA 94035-1000  
(415) 604-6909  
(415) 604-3729

Burton P. Chesterfield  
H F in Accident Investigation  
DOT / Transportation Safety Institute  
Aviation Safety Division (DTI-20)  
P.O. Box 25082  
Oklahoma City, OK 73125-5050  
(405) 954-3614  
(405) 954-3431

Robert Clarke  
Chief, Heavy Vehicle Research Div.  
Office of Crash Avoidance Research  
USDOT / NHTSA  
400 7th Street, SW  
Washington, DC 20590  
(202) 366-5664  
(202) 366-7237

Robert E. L. Davis  
Research Coordinator  
FHWA / Office of Motor Carriers  
400 7th St., S.W.  
Washington, DC 20590  
(202) 366-2997  
(202) 366-7298

Gene Farber  
IVHS Strategy & Planning  
Ford Motor Co.  
Room 284, World Headquarters  
Dearborn, MI 48121-1899  
(313) 845-5305  
(313) 594-2105

Mark Freedman  
Mgr, Transportation Safety Research  
Westat, Inc.  
1650 Research Blvd.  
Rockville, MD 20850  
(301) 294-2857  
(301) 294-2829

Deborah M. Freund  
Team Leader  
FHWA / OMC  
400 Seventh St. SW  
Washington, DC 20590  
(202) 366-5541  
(202) 366-7298

Capt. William B. Gibbs  
President  
OSprey-Acomarit Ship Mgmt., Inc.  
6550 Rock Spring Dr., Ste. 300  
Bethesda, MD 20817  
(301) 571-8500  
(301) 571-8501

Michael Goodman  
Research Psychologist - HF  
USDOT / NHTSA  
400 Seventh Street, SW  
Washington, DC 20590  
(202) 366-5677  
(202) 366-7237

Eleanor B. Govesky  
Course Manager  
H F in Accident Investigation  
DOT / Transportation Safety Institute  
Aviation Safety Division (DTI-20)  
P.O. Box 25082  
Oklahoma City, OK 73125-5050  
(405) 954-7205  
(405) 954-3431

Mitch Grossberg  
FAA Technical Center, ACD-39  
International Airport  
Atlantic City, NJ 08405

Mark Hofmann  
Chief Scientific & Technical  
Advisor for Human Factors, AXD-4  
Federal Aviation Administration  
800 Washington, DC 20591  
(202) 267-7125  
(202) 267-5795

Beverly Huey  
Suite H-A 178  
National Academy of Science  
Washington, DC 20418  
(202) 334-3307

Kate Hunter-Zaworski  
Asst. Professor  
Oregon State University  
TRI / Merryfield 100  
Corvallis, OR 97331-4304  
(503) 737-4982  
(503) 737-3462

Stephen M. Huntley  
USDOT / Volpe Center, DTS-45  
55 Broadway  
Cambridge, MA 02142  
(617) 494-2339  
(617) 494-3622

Remi Joly  
Senior Ergonomist  
Transportation Development Center  
Transport Canada  
800 Rene-Levesque Blvd. W., 6th Fl.  
Montreal, Quebec, H3B 1X9  
**CANADA**  
(514) 283-0033  
(514) 283-7158

Robert L. Kane  
Director, Neuropsychology Clinic  
Baltimore V.A. Medical Center  
Psychology Service (116B)  
10 N. Greene Street  
Baltimore, MD 21201  
(410) 605-7414  
(410) 605-7942

Barry Kantowitz  
Director  
Human Factors Trans. Ctr.  
Battelle  
4000 41st NE  
Seattle, WA 98105  
(206) 528-3252  
(206) 528-3555

Ron Knipling  
Engineering Research Psychologist  
Office of Crash Avoidance Research  
USDOT / NHTSA  
400 Seventh Street, SW  
Washington, DC 20590  
(202) 366-4733  
(202) 366-7237

George Kuehn  
Research Data Analyst  
IIT Research Institute  
10 W. 35th Street  
Chicago, IL 60616  
(312) 567-4148  
(312) 567-4608

Alex Landsburg  
Program Manager  
Maritime Administration  
MAR-250, Room 7302  
400 Seventh St., SW  
Washington, DC 20590  
(202) 366-1923  
(202) 493-2288

Lucia Lawrence  
USDOT / OST  
400 Seventh St., SW  
Washington, DC 20590

Neil Lerner  
Manager, Human Factors  
COMSIS Corporation  
8737 Colesville Rd.  
Silver Spring, MD 20910  
(301) 588-0800  
(301) 588-5922

Janno Lieber  
Assistant Secretary  
USDOT / OST  
400 Seventh St., SW  
Washington, DC 20590

Marc Mandler  
Chief, Systems Analysis Branch  
USCG R&D Center  
1082 Shennecossett Rd.  
Groton, CT 06340-6096  
(203) 441-2615  
(203) 441-2792

Truman Mast  
Human Factors Program Mgr.  
FHWA  
6300 Georgetown Pike  
McLean, VA 22101  
(703) 285-2404  
(703) 285-2113

David Mayer  
Office of Research & Engineering  
Analysis & Data Div. (RE-50)  
National Transportation Safety Board  
490 L'Enfant Plaza East, SW  
Washington, DC 20594  
(202) 382-8013  
(202) 382-6008

Richard M. Michaels  
Vice President  
P/R Michaels Associates  
1328 W. Sherwin  
Chicago, IL 60626  
(312) 764-4396  
(312) 764-4396

Charles T. Morrison, Jr.  
Program Mgr, Human Resources  
TTS-30, Room 6100  
FTA  
400 Seventh St., S.W.  
Washington, DC 20590  
(202) 366-0245  
(202) 366-3765

Joe Moyer  
Engineering Research Psychologist  
FHWA  
6300 Georgetown Pike  
McLean, VA 22101-2296  
(703) 285-2008  
(703) 285-2469

Jon Murphy  
Chief, Special Projects Div.  
Federal Railroad Administration  
400 Seventh Street, SW  
Washington, DC 20590  
(202) 366-0400  
(202) 366-7688

Ian Noy  
Chief, Ergonomics  
Transport Canada Road Safety &  
Motor Vehicle Regulation ASFBF  
344 Slater Street  
Ottawa, Ontario K1A ON5  
**CANADA**  
(613) 998-2268  
(613) 998-4831

Jeanne O'Leary  
USDOT / OST  
400 Seventh Street, SW  
Washington, DC 20590

Robert Nutter  
Chief, Industry Operations  
and Safety Division  
Nassif Building, P-13, Room 9222  
USDOT / OST  
400 Seventh St., SW  
Washington, DC 20590

Richard F. Pain  
Transportation Safety Coordinator  
Transportation Research Board  
2101 Constitution Ave., NW  
Washington, DC 20418  
(202) 334-2960  
(202) 334-2003

George Parker  
Associate Administrator for R & D  
NHTSA  
400 Seventh St., SW  
Washington, DC 20590

Norm Paulhus  
Senior Technical Adviser  
Nassif Building, DRP-1, Room 8410  
Research & Special Programs  
Administration  
400 Seventh Street, SW  
Washington, DC 20590  
(202) 366-4997

Gayle Payne  
RRP-12  
Program Analyst  
Federal Railroad Administration  
400 Seventh St., Sw  
Washington, DC 20590  
(202) 366-4930  
(202) 366-7688

Michael Perel  
Research Engineer, NRD-52  
USDOT / NHTSA  
400 Seventh Street  
Washington, DC 20590  
(202) 366-5675  
(202) 366-7237

John K. Pollard  
Project Manager  
USDOT / Volpe Center, DTS-45  
55 Broadway  
Cambridge, MA 02142  
(617) 494-2449  
(617) 494-3622

Don Pulciani  
Dir. Ops & Emergency Preparedness  
Railway Safety Directorate  
Transport Canada  
Canada Bldg, Room 155, 344 Slater  
St.  
Ottawa, Ontario K1A0N5  
**CANADA**  
(613) 957-6252  
(613) 957-6254

Thomas G. Raslear  
Engineering Psychologist  
Ofc. of Research & Development  
Federal Railroad Administration  
400 Seventh St., SW  
Washington, DC 20590  
(202) 366-6838  
(202) 366-7156

Dennis Reeves  
Department of Psychology  
Navy Medical Center  
San Diego, CA 92134-5000  
(619) 532-6058  
(619) 538-4519

Noah Rifkin  
Director of Technology Deployment  
USDOT / OST  
400 Seventh Street, SW  
Washington, DC 20590

Anita Rothblum  
Research Psychologist  
U.S. Coast Guard R&D Center  
1082 Shennecossett Road  
Groton, CT 04340  
(203) 441-2847  
(203) 441-2792

Thomas Sanquist  
Research Scientist  
Battelle  
4000 NE 41St.  
Seattle, WA 98105  
(206) 528-3240  
(206) 528-3552

David J. Schroeder, Ph.D  
Research Psychologist  
Federal Aviation Administration  
Civil Aeromedical Institute, AAM-500  
P.O. Box 25082  
Oklahoma City, OK 73125  
(405) 954-4846  
(405) 954-4852

Thomas B. Sheridan  
Professor  
Massachusetts Institute of  
Technology  
3-346 MIT  
Cambridge, MA 02139  
(617) 253-2228  
(617) 258-6575

David Shinar  
Professor  
NHTSA / TSP / NTS-33  
Room 5125B, Nassif Bldg.  
400 Seventh St., S.W.  
Washington, DC 20590  
(202) 366-9826  
(202) 366-7149

After 10/25/94,  
David Shinar  
Dept. of Industrial Engineering  
and Management  
Ben Gurion University of the Negev  
Beer Sheva, 84105,  
**ISRAEL**  
(9872) 7-472215  
(972) 7-280776

Geoffrey Silberman  
Department of Applied Physics  
John Hopkins University  
Baltimore, MD

Ronald R. Simmons  
Program Manager  
FAA  
2525 N. 10th St., #106  
Arlington, VA 22201  
(202) 366-6434

Alison Smiley  
Human Factors North  
118 Baldwin Street  
Toronto, M5T 1L6  
**CANADA**  
(416) 596-1252  
(416) 596-6946

Myriam Witkin Smith  
Research Psychologist  
USCG R&D Center  
1082 Shennecossett Road  
Groton, CT 06340-6096  
(203) 441-2844  
(203) 441-2792

Mary D. Stearns  
USDOT / Volpe Center, DTS-45  
55 Broadway  
Cambridge, MA 02142  
(617) 494-2617  
(617) 494-3622

Robert Stein  
Senior Policy Analyst  
USDOT  
400 Seventh St., SW  
Washington, DC 20590  
(202) 366-4846  
(202) 366-7618

John A. Stern  
Chair & Prof. Psychology  
Washington University  
1 Brookings Drive  
St. Louis, MO 63130  
(314) 935-6567  
(314) 935-7588

E. Don Sussman  
USDOT / Volpe Center, DTS-45  
55 Broadway  
Cambridge, MA 02142  
(617) 494-2413  
(617) 494-3622

Garold R. Thomas  
Research Mgr., Operating Practices  
Ofc. of Research & Development  
USDOT / FRA  
700 Seventh Street, SW  
Washington, DC 20590  
202-366-0468  
202-366-7150

Tove Titlow  
Program Analyst  
FAA / ASF / ASA  
400 Seventh St., SW, Rm 2227  
Washington, DC 20590  
(202) 366-6590  
(202) 366-7095

Dan Wagner  
Airway Facilities H.F. Program Mgr  
FAA Technical Center, ACD-39  
International Airport  
Atlantic City, NJ 08405  
(609) 485-4191  
(609) 485-6218

William A. Wheeler  
Deputy Manager  
Battelle Human Factors Trans. Ctr.  
4000 N.E. 41st  
Seattle, WA 98105  
(206) 528-3258  
(206) 528-3555

Clyde Woodle  
Executive Director  
Trucking Research Institute  
2200 Mill Road  
Alexandria, VA 22314  
(703) 838-1966  
(703) 838-0291

Dennis Wylie  
Principal Scientist  
Essex Corporation  
5775 Dawson Ave.  
Goleta, CA 93117  
(805) 964-0591  
(805) 964-4392

Lawrence Zeitlin  
Professor  
City University of New York  
12 Brook Lane  
Peekskill, NY 10566  
(914) 737-4905  
(914) 737-4905



Susan A. Zimmerman  
Program Manager  
Ofc. of Safety & Technical Assistance  
USDOT / FTA  
400 Seventh St., SW, Rm. 6432  
Washington, DC 20590  
(202) 366-0248

## **PROFILES OF PAPER PRESENTERS**

### **R. Wade Allen**

R. Wade Allen received his B.S. and M.S. degrees in engineering from UCLA in 1962 and 1965, respectively. He is responsible for STI's ground vehicle work and human factors efforts. He has actively carried out and directed analysis, simulation, and field test work on the stability of a range of ground vehicles including cars, vans, light pickups and utility vehicles, and all-terrain vehicles (ATV's). He has served as Principal Investigator for Department of Transportation projects to develop and validate models and analysis procedures for quantifying driver/vehicle crash avoidance behavior and vehicle rollover behavior. Mr. Allen has also served as Principal Investigator on several studies to develop rider/vehicle models field test procedures for ATV's.

Regarding human factors efforts, Mr. Allen has been Principal Investigator for numerous studies on driver behavior, including driver response to traditional and new technology display and control systems, cellular phones and traffic control devices. He has also been experimental programs on the study of driving performance impairment by alcohol, marijuana, and fatigue. This work has concerned control behavior and more cognitive tasks such as decision making.

He served as consultant to the UCLA ITTE driving simulator programs with particular contributions to the experimental plans, measurement of driver describing functions, and data analysis and interpretation. Previously, he was engaged in the research and development of psychomotor tasks designed to measure the dynamic response of human operators engaged in manual control tasks, and a display technology program involving detailed analysis and experimental investigation of display requirements for manual control systems. He also was project engineer for a series of investigations of the effects of vibration on manual control performance. This effort included the development of biomechanical models and measurement of human operator response and performance.

Mr. Allen has been responsible for a large part of the accident reconstruction work carried out at STI. This work has involved vehicle dynamics, the roadway environment, and driver behavior considerations. Mr. Allen has served as an expert witness on numerous cases giving depositions and courtroom testimony. Mr. Allen has worked on cases filed in Federal and Superior courts, involving vehicle defects, driver capabilities, road conditions, and signing, etc.

Mr. Allen's professional affiliations include Fellow of the institute for the Advancement of Engineering and of the Human Factors and Ergonomics Society (formerly the Human Factors Society) and a past editor of the Human Factors Society directory; member of IEEE, SAE, AIAA, and the Society for Computer Simulation; Secretary of the Transportation Research Board (TRB) Committee A3B06 (Simulation and Measurement of Vehicle and Operator Performance); member of TRB Committee A3B12 (Motor Vehicle Technology); Chairman of the Design Requirements Subcommittee of the IVHS/America Committee on Safety and Human Factors.

He was awarded the Human Factors Society A.R. Lauer Traffic Safety Award in 1989 and the Arch T. Colewell Award for an SAE paper in 1991. Mr. Allen is a Registered Professional Engineer, State of California, Control Systems Branch. He holds two patents: (1) Display Generator for Simulating Vehicle Operation, No. 4,182,053; and (2) Device for Measuring Human Performance, No. 4,983,125.

### **Alison Smiley**

Alison Smiley earned her M.A.Sc. And Ph.D. degrees at the University of Waterloo in systems design engineering with a number of scholarships and awards. She has served as a research scientist at the Southern California Research Institute and as a design engineer for Ontario Hydro. In addition to her present post as President of Human Factors North, Inc., Dr. Smiley is an adjunct professor in industrial engineering at the University of Toronto.

Projects Dr. Smiley has worked on include evaluation of pilot decision making related to anti-icing and de-icing for Allied Signal Aerospace Canada; assessment of crew work/rest schedules for the Canadian Coast Guard; evaluation of methods to verify operations in nuclear plants for the Canadian Atomic Energy Control Board; and assessment of potential driver distractions on freeways due to low-flying aircraft. She has been involved in the European Economic Community's DRIVE Project in assessing human factors issues in the design of generic driver support systems, and has appeared as a human factors expert witness on work-rest schedules for the Royal Commission on the Hinton Rail Collision. She has undertaken work recently on the application of high technology in vehicles and evidence of behavioral compensation with antilock brakes.

Dr. Smiley, who also specializes in nuclear power plant safety, has participated in a control room design review and in the design of a security monitoring room for a nuclear power generating station; and has conducted studies on the measurement of cognitive error in nuclear operators, the assessment of 12-hour shifts, and maintenance performance monitoring.

Dr. Smiley currently chairs the Transportation Research Board (TRB) Committee on Vehicle User Characteristics; and is a member of the Committee on Simulation and Measurement of Vehicle and Operator Performance, and of the National Cooperative Highway Research Program Project Panel on Determination of Stopping Sight Distances. She is a past member of the TRB Committee on Benefits and Costs of Alternative Federal Blood Alcohol Concentration Standards for Commercial Vehicle Operators. She is the author of numerous articles and publications.





