

IDEA

**Innovations Deserving
Exploratory Analysis Programs**

HIGHWAY

New IDEAs for Highway Systems

Annual Progress Report

July 1998 — June 1999

TRANSPORTATION RESEARCH BOARD • NATIONAL RESEARCH COUNCIL

TR
1
.A3
N35
1999

TRANSPORTATION RESEARCH BOARD

EXECUTIVE COMMITTEE OFFICERS

CHAIRMAN: Wayne Shackelford, Commissioner,
Georgia Department of Transportation

VICE CHAIRMAN: Martin Wachs, Director, Institute of Transportation
Studies, University of California, Berkeley

EXECUTIVE DIRECTOR: Robert E. Skinner, Jr.,
Transportation Research Board

MEMBERS

SHARON D. BANKS, General Manager, AC Transit, Oakland, California
(past chair, 1998)

THOMAS F. BARRY, Jr., Secretary of Transportation, Florida Department
of Transportation

BRIAN J.L. BERRY, Lloyd Viel Berkner Regental Professor, University of
Texas at Dallas

SARAH C. CAMPBELL, President, TransManagement, Inc., Washington, DC

ANNE P. CANBY, Secretary of Transportation, Delaware Department of
Transportation

E. DEAN CARLSON, Secretary, Kansas Department of Transportation

JOANNE F. CASEY, President, Intermodal Association of North America,
Greenbelt, Maryland

JOHN W. FISHER, Joseph T. Stuart Professor of Civil Engineering and
Director, ATLSS Engineering Research Center, Lehigh University

GORMAN GILBERT, Director, Institute for Transportation Research and
Education, North Carolina State University

Delon Hampton, Chairman & CED, Delon Hampton & Associates,
Chartered, Washington, DC

LESTER A. HOEL, L.A. Lacy Distinguished Professor, University of Virginia
(past chair, 1986)

JAMES L. LAMMIE, Director, Parsons Brinckerhoff, Inc., New York City,
New York

THOMAS F. LARWIN, General Manager, San Diego Metropolitan Transit
Development Board

BRADLEY L. MALLORY, Secretary of Transportation, Pennsylvania
Department of Transportation

JEFFREY J. MCCAIG, President & CEO, Trimac Corporation

MARSHALL W. MOORE, Director, North Dakota Dept. of Transportation

JEFFREY R. MORELAND, Senior Vice President - Law and Chief of Staff,
Burlington Northern Santa Fe Corporation

SID MORRISON, Secretary of Transportation, Washington State Department
of Transportation

JOHN P. PODRMAN, Staff Director, Capital District Transportation
Committee, Albany, New York

ANDREA RINKER, Executive Director, Port of Tacoma

JOHN M. SAMUELS, Vice President—Operations Planning & Budget
(Operations Division), Norfolk Southern Corporation

CHARLES H. THOMPSON, Secretary, Wisconsin Department of
Transportation

JAMES A. WILDING, President and Chief Executive Officer, Metropolitan
Washington Airports Authority

DAVID N. WORMLEY, Dean of Engineering, Pennsylvania State University

EX OFFICIO MEMBERS

MIKE ADOTT, President, National Asphalt Pavement Association

JOE N. BALLARD, Chief of Engineers and Commander, U.S. Army Corps
of Engineers

KELLEY S. COYNER, Administrator, Research & Special Programs
Administration, U.S. Department of Transportation

ALEXANDER CRISTOFARO, Acting Office Director, Office of Policy and
Reinvention, U.S. Environmental Protection Agency

MORTIMER L. DOWNEY, Deputy Secretary, Office of the Secretary,
U.S. Department of Transportation

NURIA I. FERNANDEZ, Acting Administrator, Federal Transit Administration

JANE F. GARVEY, Administrator, Federal Aviation Administration

EDWARD R. HAMBERGER, President & CEO, Association of American
Railroads

CLYDE J. HART, Jr., Administrator, Maritime Administration

JOHN C. HORSLEY, Executive Director, American Association of State
Highway and Transportation Officials

JAMES M. LOY, Commandant, U.S. Coast Guard

ROSALYN G. MILLMAN, Acting Administrator, National Highway Traffic
Safety Administration

WILLIAM W. MILLAR, President, American Public Transit Association

JOLENE M. MOLITORIS, Administrator, Federal Railroad Administration

VALENTIN J. RIVA, President & CEO, American Concrete Pavement
Association

ASHISH K. SEN, Director, Bureau of Transportation Statistics

KENNETH R. WYKLE, Administrator, Federal Highway Administration

NEW IDEAS FOR HIGHWAY SYSTEMS

An Annual Progress Report of the NCHRP Highway IDEA Program

JULY 1998 – JUNE 1999

Transportation Research Board

National Research Council

MTA LIBRARY

27381

TE
1
.A3
N35
1999

JAN 02 2000

NCHRP-IDEA PROGRAM COMMITTEE

Earl C. Shirley, Chairman
Consulting Engineer, California

Charles Arnold
Michigan Department of Transportation

Sidney Green
Terra Tek

Robert Gubala
Consulting Engineer, Connecticut

Susan Martinovich
Nevada Department of Transportation

Priscilla Nelson
National Science Foundation

Arunprakash Shirole
Consulting Engineer, Minnesota

Lawrence Smith
Florida Department of Transportation (Retired)

Richard Stewart
South Carolina Department of Transportation

James Taylor
University of Notre Dame

Paul Teng
Federal Highway Administration

Jon Underwood
Texas Department of Transportation

DOT/FHWA Research Programs
James Wentworth, *Federal Highway Administration*

NCHRP Program
Crawford Jencks, *Manager*

NCHRP-IDEA Program
Inam Jawed, *Manager*

TRB Divisions
Robert E. Skinner, Jr., *Executive Director*
Marcia A. Appel, *Director, Administration and Finance*
Stephen R. Godwin, *Director, Studies and Information Services*
Neil F. Hawks, *Director, Special Programs*
Robert J. Reilly, *Director, Cooperative Research Programs*
Robert E. Spicher, *Director, Technical Activities*

TABLE OF CONTENTS

SECTION 1: Completed IDEA Projects

- 1 *On-Line Real-Time Measurement and Control of Aggregate Gradation in Asphalt Plants*
Felix ALBA Consultants Inc., Murray, Utah
STAKER Paving and Construction Company, Salt Lake City, Utah
- 2 *A Method for Measuring Water-Stripping Resistance of Asphalt/Siliceous Aggregate Mixtures*
National Institute of Standards and Technology, Gaithersburg, Maryland
- 3 *Guidelines for Low-Cost Sprayed-Zinc Galvanic Anode for Controlling Corrosion of Reinforcing Steel in Marine Bridge Substructures*
University of South Florida
Florida Department of Transportation, Gainesville
- 4 *Exploring the Feasibility of Replacing Latex with Asphalt Emulsion for Use in Bridge Deck Overlays*
Purdue University, West Lafayette, Indiana
- 5 *Magnetic Resonance for In Situ Determination of Asphalt Aging and Moisture Content*
Southwest Research Institute, San Antonio, Texas
- 6 *Excogitated Composite Multifunctional Layer for Pavement Systems*
University of Illinois, Urbana-Champaign
- 7 *Strategy for Coating Structural Steel Without Stringent Blasting Regulations*
Steel Structures Painting Council, Pittsburgh, Pennsylvania
- 8 *Conservation Traffic Control Load Switch*
CLS Incorporated, Westerville, Ohio
- 9 *Corrosion-Resistant Steel Reinforcing Bars*
University of Kansas, Lawrence
- 10 *Metallic Coating for Corrosion Protection of Steel Rebars*
SRI International, Menlo Park, California
- 11 *Rehabilitation of Steel Bridges Through the Application of Advanced Composite Materials*
University of Delaware, Newark
- 12 *Advanced Testing of an Automatic Nondestructive Evaluation System for Highway Pavement Surface Condition Assessment*
Illinois Institute of Technology, Chicago

- 13 *New Additive for Improved Durability of Concrete*
University of Connecticut
- 14 *Unreinforced, Centrally Prestressed Concrete Columns and Piles*
Florida Atlantic University, Boca Raton
- 15 *Portable Laser Road Crew Warning System*
Lockheed Martin Corporation, Manassas, Virginia
- 16 *Laser Removal of Paint on Pavement*
MOXTEX, Incorporated, Orem, Utah
- 17 *Self-Contained Portable Device for SHRP Binder Testing: Field QC/QA Testing with the Duomorph*
University of Illinois, Urbana-Champaign
- 18 *New Principles of Design for Cutting Tools to Repair and Remove Pavements Based on the Effect of Lateral Propagation of Cracks Under Contact Loading*
POTOK Centre, Kiev, Ukraine
- 19 *Aluminum Bronze Alloy for Corrosion-Resistant Rebar*
Man-Tech Development, Inc., Mansfield, Texas
- 20 *Carbon Dioxide (Dry Ice) Cleaning to Remove Highway Road Markings and Stripes*
Tomco Equipment Company, Loganville, Georgia
- 21 *Development of LED Light Source for Traffic Control Devices*
The Last Resource, Inc., Bellefonte, Pennsylvania
- 22 *Use of Phase Change Materials to Prevent Overnight Freezing of Bridge Decks*
University of Dayton Research Institute, Dayton, Ohio
- 23 *Lead-Based Paint Removal from Steel Structures*
EMEC Consultants, Export, Pennsylvania
- 24 *Fiber-Optic Strain Sensor System for Long-Term Monitoring of Highway Structures*
Simula Government Products, Inc., Phoenix, Arizona
- 25 *Basalt Fiber Composite Reinforcement for Concrete*
Research and Technology, Inc., Madison, Wisconsin
- 26 *Conservation Control Load Switch Operational Tests*
CLS Incorporated, Westerville, Ohio
- 27 *Automated Bridge Deck Anti- and Deicing System*
University of Utah, Salt Lake City
- 28 *Corrosion-Resistant Low-Carbon Steels for Concrete Reinforcement*
University of California, Berkeley

-
- 29 *Superelasticity-Based Materials for Bridge Rehabilitation*
DPD, Inc., Lansing, Michigan
Michigan State University, East Lansing
- 30 *Rapid Replacement Composite Bridge No. 1*
Kansas Structural Composites, Inc., Russell, Kansas.
- 32 *Testing and Trial Deployment of a Cost-Effective and Real-Time Asphalt Pavement Quality Indicator System*
TransTech Systems, Inc., Latham, New York
- 34 *Highway Guardrail Infrastructure: Safer Terminal Designs*
Duke University, Durham, North Carolina

SECTION 2: Active IDEA Projects

- 16 *Laser Removal of Paint on Pavement*
MOXTEX, Incorporated, Orem, Utah
- 31 *Cost-Effective Microwave Sensor to Detect Highway Road Conditions*
University of Wyoming, Laramie
- 33 *Evaluation of a New Rehabilitation Technology for Bridge Piers with Composite Materials*
West Virginia University, Morgantown
- 37 *In-Service Repair of Highway Bridges and Pavements by Internal Time Release of Repair Chemicals*
Illinois Universities Transportation Research Consortium, Chicago
- 38 *Paint Removal from Steel Structures: Testing and Demonstration of ElectroStrip[®] Process*
EMEC Consultants, Export and New Kensington, Pennsylvania
- 40 *Estimating Truck Attributes from Bridge Strain Data Using Neural Networks*
University of Florida, Gainesville, Florida
- 41 *Field Testing with the Duomorph: A Self-Contained Portable Device for SHRP Binder Testing*
University of Illinois, Urbana-Champaign, Illinois
- 42 *Dual-Core Fiber Optic WIM System*
University of Connecticut, Storrs, Connecticut
- 43 *Robotic System for Underwater Bridge Inspection and Scour Evaluation*
Kansas State University
- 44 *Roller-Mountable Asphalt Pavement Quality Indicator Using Differential Microwave Signals*
Iowa State University

-
- 45 *Performance Evaluation of Basalt Fibers and Composite Rebars as Concrete Reinforcement*
Research and Technology, Inc., Madison, Wisconsin
South Dakota School of Mines and Technology, Rapid City
- 46 *Fiber-Reinforced Polymer Honeycomb Short-Span Bridge for Rapid Installation*
Kansas Structural Composites, Inc., Russell, Kansas
Kansas Department of Transportation, Topeka
- 47 *Pavement Quality Indicator: Field Operational Testing and Product Transfer*
TransTech Systems, Inc., Latham, New York
- 48 *Field Trial of Shape Memory-Based Rehabilitation System*
DPD, Inc., East Lansing, Michigan
Michigan State University, East Lansing
- 49 *Automation of Legends Painting*
Pavement Marking Technologies, Inc., Menlo Park, California
- 50 *Damper Systems for Suppression of Bridge Stay Cable Vibrations*
Construction Technology Laboratories, Inc., Skokie, Illinois
- 51 *Application of Advanced Composites to Steel Bridge Retrofitting*
University of Delaware, Newark
- 52 *Environmentally Friendly Passivating Coatings for Steel Rebars*
Neely Industries, Inc., Butler, Pennsylvania
University of South Florida, Tampa
Florida Department of Transportation, Tallahassee
University of Rhode Island, Kingston
- 54 *Novel Approach for Predicting Remaining Life of Concrete Bridge Structures*
University of Arizona, Tucson
- 55 *Design, Development, and Verification of an Advanced In Situ Shear Strength Test Facility
for Asphalt Concrete Pavements*
Carleton University, Ottawa, Ontario, Canada
- 56 *Bridge Inspection with Serpentine Robots*
Carnegie Mellon University, Pittsburgh, Pennsylvania
- 57 *Stabilization of Landslides Using Wick Drains*
University of Missouri-Rolla
- 58 *Long Gauge-Length Interferometric Fiber-Optic Sensors for Condition Assessment of
Bridge Structures*
Pennsylvania State University
- 59 *Control Systems for Live Load and Live Load Effects On Bridges*
University of Michigan

-
- 61 *The PTDM (Pavement Thickness Density Meter)*
Infrasense, Inc., Menlo Park, California
 - 62 *A New Technique for Characterizing Pavement Surface Profiles and Textures*
Texas A&M University
 - 63 *Manufacturing and Testing of a Filament-Wound Composite Bridge Superstructure*
University of Illinois, Urbana-Champaign
 - 64 *Quantitative Characterization of Asphalt Concretes Using High-Resolution X-Ray Computed Tomography (CT)*
University of Texas, Austin

SECTION 3: NSF/NRC-IDEA Cooperative Projects

- 1 *Control System for Highway Load Effects*
University of Michigan, Ann Arbor
- 2 *Pulse-Echo Tomographic Microwave Imaging Systems for Quantitative NDE of Civil Structures and Materials*
University of California, Santa Barbara

APPENDIX: Listing of IDEA Projects Awarded to Date in ITS-IDEA, Transit-IDEA, and High-Speed Rail-IDEA Programs

INTRODUCTION

This annual report presents a summary of progress on investigations conducted as part of the Innovations Deserving Exploratory Analysis (IDEA) program for the National Cooperative Highway Research Program (NCHRP). The NCHRP-IDEA program is jointly funded by the Federal Highway Administration and state highway agencies in cooperation with the American Association of State Highway and Transportation Officials.

NCHRP-IDEA is one of four IDEA programs managed by the Transportation Research Board (TRB) to foster innovation in highway and intermodal surface transportation systems. NCHRP-IDEA nurtures new concepts for technologies, methods, and processes for application to highway systems in broad technical areas such as highway design and construction, materials, operations, and maintenance. The other IDEA program areas are

- Transit-IDEA, which focuses on products and results for transit practice in support of the Transit Cooperative Research Program;
- ITS-IDEA, which focuses on products and results for the development and deployment of intelligent transportation systems in support of the U.S. Department of Transportation's national ITS program; and
- High-Speed Rail-IDEA, which focuses on advanced technologies for high-speed rail operations in support of the Federal Railroad Administration's Next Generation High-Speed Rail Program.

The IDEA programs are integrated to support advances in highway, transit, ITS, rail, and intermodal systems. The appendix lists IDEA projects in ITS, high-speed rail, and transit IDEA programs.

The IDEA program is open to all individuals, including entrepreneurs, small and large businesses, and institutions. The program provides an opportunity to investigate new and unproven concepts or to evaluate other novel applications of technologies that have been tried, tested, or used for highway, transit, high-speed rail, or intermodal systems practice.

The selection of each IDEA investigation is made by consensus recommendations from panels of national experts in highway and transportation research and practice and is approved by the NCHRP-IDEA Project Committee, whose members are listed at the beginning of this report. A technical expert is selected from outside TRB to serve as a voluntary advisor to mentor each IDEA project. The technical project advisor provides continuing advice and counsel on the IDEA investigation to the investigator and the IDEA program office. In order to begin the product transfer process from the initiation of each IDEA project, a regional panel of experts is nominated to work with the investigator on product development and transfer to highway practice. The products emerging from the NCHRP-IDEA project support a range of innovative developments for highway user services and for advancing highway systems.

Section 1 of this report presents short descriptions of projects completed before the 1999 program year. The products and results from these projects have been applied or are available for further investigation for application to highway practice. The product status is described under each project. Because of limitations on IDEA resources, not all IDEA concepts that

prove feasible can be accommodated for follow-up funding from NCHRP-IDEA for product transfer. Section 2 presents reports of investigations on projects active or completed during the 1999 program year; several projects in this section are in the initial stages of investigation. Section 3 presents IDEA projects performed under a cost-sharing initiative with the National Science Foundation.

In selecting new concepts, the IDEA program balances the quest for new products with an understanding of the barriers each product may face for application to practice. Assessing the level of readiness for deployment of IDEA products and results is important in deciding on follow-up actions that are necessary to transfer the IDEA product to practice. The annual report is intended to provide highway practitioners with the background on each IDEA investigation and product in development so that a dialogue on its potential transfer can take place between the investigator and highway practitioners.

The IDEA programs welcome your comments, suggestions, or recommendations on IDEA projects, products, and results presented in this report. Please forward them to The IDEA Program, Transportation Research Board, 2101 Constitution Avenue, NW, Washington, DC 20418; fax: 202-334-3471; e-mail: TRB-IDEA@NAS.EDU.

SECTION 1 COMPLETED IDEA PROJECTS

This section presents brief summaries of projects completed before the 1999 program year. The products have been applied or are available for further investigation for application to highway practice. The product status is described under each project. Because of limitations on IDEA resources, not all IDEA concepts that prove feasible can be accommodated for follow-up funding by NCHRP-IDEA.

ON-LINE REAL-TIME MEASUREMENT AND CONTROL OF AGGREGATE GRADATION IN ASPHALT PLANTS

NCHRP-IDEA Project 1

Felix Alba [Tel: (801) 264-8294, Fax: (801) 264-8293]

Felix ALBA Consultants Inc., Murray, Utah

Mike Worischeck and Steve Madrigal,

STAKER Paving and Construction Company, Salt Lake City, Utah

This IDEA project developed and tested a non-contact video imaging and analysis system for continuous on-line measurement and flow control of aggregate gradation (size distribution) in an asphalt plant.

The system is based on image analysis technology. Figure 1 shows schematically the image analysis for controlling the aggregate gradation. The hardware system consists of a lamp and a line-scan video camera installed over feeder belts from each of the cold bins. The software system incorporates the principles of machine vision, image processing, stereology, and mathematical analysis.

The raw images of the aggregates falling onto the master belt are gathered by frame grabbers and preprocessed by image processing boards connected to the data bus of a host computer. Additional image processing and particle recognition algorithms determine the chord-length distribution of aggregates from video images. The chord-length distribution is then transformed into volumetric (sieve) size gradations. Proportioning factors for the bins are applied to comply with the job mix formula, and belt feeder speeds are adjusted accordingly to deliver a uniform flow of aggregates automatically.

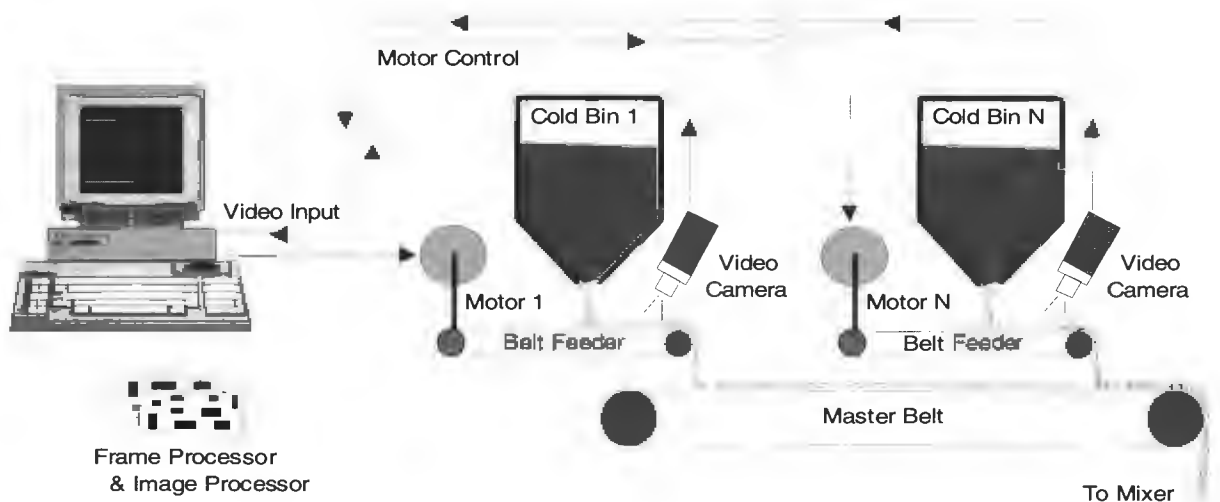

Figure 1

Aggregate gradation control technological concept.

Field experiments at an asphalt plant show that the system can measure coarse aggregate gradation (3/4", 1/2", 3/8") with a reproducibility better than 2% and an accuracy (relative to standard sieving) better than 4% on each mesh. The system slightly underreported finer particles, which was attributed to agglomeration of particles under humid plant conditions. The problem was satisfactorily resolved using a semi-empirical procedure. The IDEA product is ready for field operational testing and marketing. The investigator is considering potential collaborative arrangements with businesses in the U.S. and Europe for marketing the product. A special two-page IDEA product report, *On-Line Real-Time Measurement and Flow Control of Aggregate Gradation in Asphalt Plants Using Video Imaging and Computerized Image Analysis*, was released in September 1995. The final report is available from the National Technical Information Service (NTIS # PB97-141642).

A METHOD FOR MEASURING WATER-STRIPPING RESISTANCE OF ASPHALT/SILICEOUS AGGREGATE MIXTURES

NCHRP-IDEA Project 2

Tinh Nguyen [Tel: (301) 975-6718, Fax: (301) 990-6891] and Eric Byrd
National Institute of Standards and Technology, Gaithersburg, Maryland

This project developed techniques to assess the stripping resistance of asphalts on siliceous aggregates. The loss of asphalt/aggregate bond strength (adhesion) in the presence of water or high relative humidity is believed to be due to the buildup of a water layer at the asphalt/aggregate interface. Measuring either the thickness of the interfacial water layer or the adhesion loss of the asphalt/aggregate mixture as a function of exposure to water provides a method for assessing the stripping resistance of an asphalt/aggregate mixture.

The first technique, in situ measurement of the water layer at the asphalt/aggregate interface, is a nondestructive, quantitative technique based on Fourier transform infrared spectroscopy in the multiple internal reflection mode (FTIR-MIR). In this technique, water reaching the asphalt/siliceous aggregate interface is detected by the evanescent wave, which is produced by the total internal reflection of the infrared radiation (Figure 1). This technique provides information on the stripping of asphalt at the molecular level.

The second technique relies on the use of a pneumatic pull-off adhesion tester combined with a porous stub that allows water to migrate through the asphalt film to the asphalt/aggregate interface. This test was initially developed to verify the adhesion loss/water layer thickness relation. However, due to its ease of use, reproducibility, and portability, this test can be used to rapidly test the water-stripping resistance of an asphalt on an aggregate in the field as well as in the laboratory.

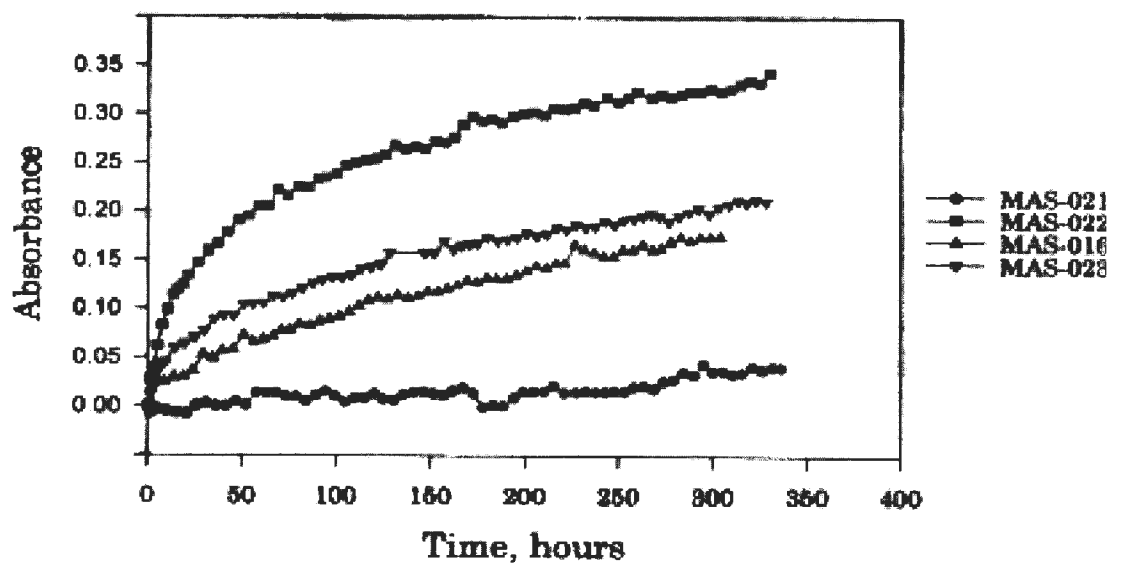

Figure 1

FTIR-MIR intensity of the water layer at the asphalt/siliceous substrate interface for different anti-stripping agents.

A number of asphalts from the SHRP Materials Reference Library were used in this investigation. The asphalt film thickness for testing the bond between asphalt and aggregate exposed to water was optimized. A correlation between bond strength and the amount or thickness of the water layer at the asphalt-aggregate interface was established. This information forms the basis for a nondestructive test based on FTIR-MIR for determining the water stripping resistance of asphalt-siliceous aggregate mixtures. The concept has proven feasible but the technique is limited to laboratory examination of field samples. The final report is available from the National Technical Information Service (NTIS # PB96-197249).

GUIDELINES FOR LOW-COST SPRAYED-ZINC GALVANIC ANODE FOR CONTROLLING CORROSION OF REINFORCING STEEL IN MARINE BRIDGE SUBSTRUCTURES

NCHRP-IDEA Project 3

Alberto A. Sagues [Tel: (813) 974-2275, Fax: (813) 974-3651]
University of South Florida

Rodney G. Powers, Florida Department of Transportation, Gainesville

The project developed guidelines for using sprayed zinc (as a sacrificial anode system) for protecting reinforcing steel (acting as the cathode) from corrosion in marine bridge structures. Sacrificial cathodic protection by means of sprayed-zinc galvanic anodes is a low-cost alternative to conventional cathodic protection of these substructure components. The surface of the spalled concrete and exposed rebar is abrasively cleaned and sprayed with zinc, using commonly available metallizing equipment. An electrical connection between the zinc and the steel is established directly. Concrete patching is not needed unless required for structural reasons, in which case the zinc is applied over the repaired concrete and a stud is used to connect the steel with the sprayed zinc. The finished cost ranges from \$60 to \$120/m². The method is applicable to a wide variety of structural components.

Laboratory and field experiments demonstrated the feasibility of the proposed approach. Additional performance data were obtained in a large-scale field application (Figure 1). The fieldwork was carried out in collaboration with the Florida DOT during the rehabilitation of



Figure 1

Field installation, Bahia Honda Bridge,
Florida Keys.

the Howard Franklin Bridge on Tampa Bay (State Project 15190-3487). The tests showed adequate probe and steel polarization (typically exceeding the 100-mV depolarization criterion) with moderate current demand (below 1 mA/sq. ft.) indicating continued cathodic protection of steel reinforcement in the substructure. Based on field results, a manual on the use of sprayed zinc for the protection of marine substructures was prepared. The product is undergoing large-scale field trials by the Florida DOT. A special two-page IDEA product report, *Sacrificial Sprayed-Zinc Galvanic Anode System for Corrosion Protection of Reinforced Concrete in Marine Substructures*, was released in June 1995. The final report is available from the National Technical Information Service (NTIS # PB97-141766).

EXPLORING THE FEASIBILITY OF REPLACING LATEX WITH ASPHALT EMULSION FOR USE IN BRIDGE DECK OVERLAYS

NCHRP-IDEA Project 4

Jan Olek, Menashi D. Cohen [Tel: (317) 494-5018, Fax: (317) 496-1364],
and Sidney Diamond, Purdue University, West Lafayette, Indiana

This project explored the feasibility of using asphalt emulsion as a low-cost replacement for latex in portland cement concrete for highway applications. The product was expected to combine the advantages of portland cement concrete (strength, stiffness) and polymer (ability to partly plug pores and form a membrane-like film that reduces the ingress of aggressive or corrosive elements).

The research focused on selecting suitable asphalt emulsion systems and designing and testing mortar and concrete with asphalt emulsion additions. Results showed that addition of emulsion reduced the workability and compressive and flexural strengths of concrete as compared with conventional concrete. The addition of emulsion also increased the amount of entrained air in concrete, which partly accounted for the strength reduction. The asphalt modified concrete, however, showed excellent freeze-thaw durability (Figure 1). Moist curing appeared to have a better effect on strength development than air curing. Tests also showed that using

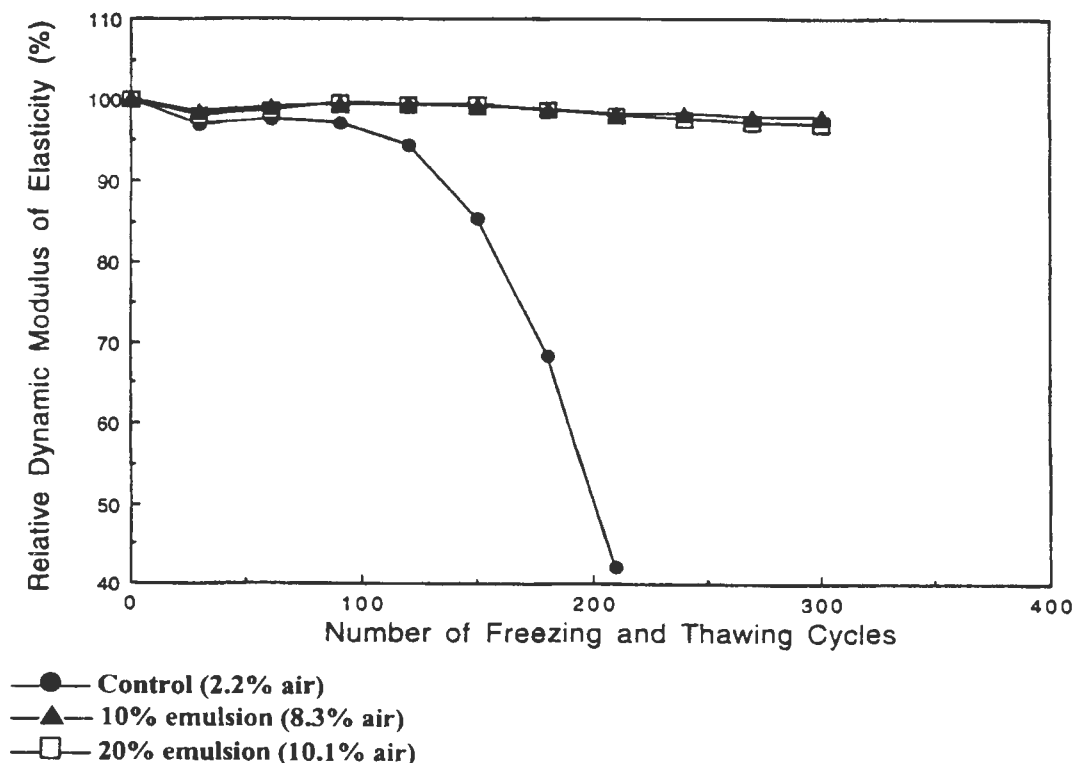

Figure 1

Freezing and thawing test results for plain and asphalt emulsion-modified concrete.

pozzolanic materials (fly ash or silica fume) in combination with asphalt emulsion significantly reduced the chloride permeability of mortars.

Additional research and field evaluation are needed before the full implementation of this product for highway applications. No additional project action is planned by NCHRP-IDEA. The final report is available from the National Technical Information Service (NTIS # PB95-267704).

MAGNETIC RESONANCE FOR IN SITU DETERMINATION OF ASPHALT AGING AND MOISTURE CONTENT

NCHRP-IDEA Project 5

J. Derwin King [Tel: (210) 684-5111, Fax: (210) 647-4325] and Qing Wen Ni
Southwest Research Institute, San Antonio, Texas

This project developed and tested a system based on magnetic resonance (MR) technologies for in-motion inspection of asphalt for rapid determination of pavement aging, moisture content, and the condition of asphalt concrete roadways. Compared with other sensing methods, MR, which includes both nuclear magnetic resonance (NMR) and electron paramagnetic resonance (EPR), offers potentially significant advantages for in situ asphalt inspection, insofar as it is nondestructive and safe, makes bulk measurements, and is rapid and suitable for on-line, in-motion measurements.

A set of 12 asphalt samples from the SHRP Reference Materials Library was used, representing a wide variation in properties that affect asphalt aging. Changes in the hydrogen NMR spectral characteristics (signal amplitude and spin-lattice and spin-spin relaxation times) of asphalt samples as a result of aging, heat treatment, oxidation, and moisture were monitored. EPR measurements provided additional information and correlations.

The results showed good correlation of the NMR data with the viscosity parameters and with aging induced by loss of volatiles and by accelerated oxidation. EPR studies of neat asphalts showed the typical hydrocarbon response from all samples plus a large multippeak vanadium spectrum from some samples. Vanadium spectra of lower amplitude were observed in most

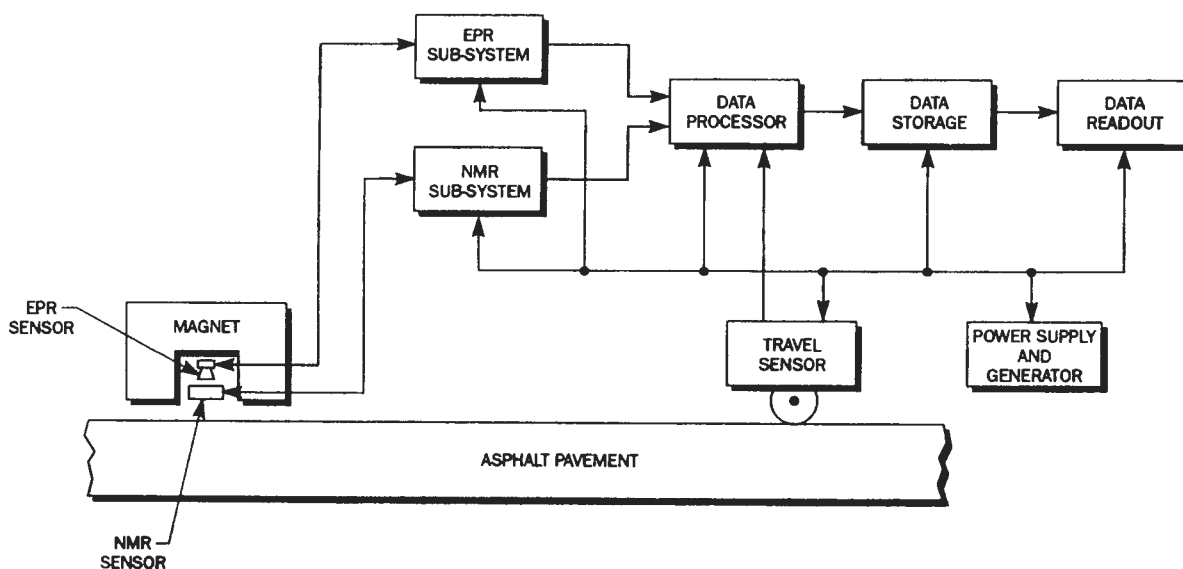

Figure 1

MR system for in situ asphalt inspection.

other samples in proportion to its concentration. The EPR vanadium signal can be used to provide a basis for correction of the NMR data for the effects of this paramagnetic element on the NMR data to make the pavement inspection independent of the types of asphalts and aggregates.

The combination of NMR and EPR techniques was shown to be an effective tool for assessing asphalt condition in pavements. The two resonance systems can use the same magnet and be easily integrated to work in tandem to determine asphalt condition. The system can be mounted on a small trailer for mobile in situ inspection. A recommended field design configuration is shown in Figure 1. Extensive field verification of the system is required for the IDEA product transfer. The final report is available from the National Technical Information Service (NTIS # PB95-267688).

EXCOGITATED COMPOSITE MULTIFUNCTIONAL LAYER FOR PAVEMENT SYSTEMS

NCHRP-IDEA Project 6

Barry J. Dempsey [Tel: (217) 333-3963, Fax: (217) 333-4464]
University of Illinois, Urbana-Champaign, Illinois

The project evaluated a concept of a three-dimensional composite layer design for pavement construction for improved performance and service life. The excogitated composite multifunctional (ECM) layer (Figure 1) will satisfy multiple functions in the pavement system by providing for subbase layer-subgrade separation, subbase shear strength, subbase tensile strength, drainage, and protection of the subgrade from surface infiltration.

The work involved material selection and design and fabrication of the composite layer. A number of synthetic and natural materials were evaluated and several performance-related parameters of the layer were measured. The layer strength was increased significantly by changing the polymer blend in the polyethylene structure and by utilizing a stiffer geotextile. The load-deflection relationship and shear stress for this new layer also showed improvements.

The composite layer was evaluated and compared in large-scale laboratory tests. A test cell, 6 ft. by 6 ft. by 40 in., was constructed with an overhead frame for mounting a hydraulic ram to perform dynamic testing of the composite layer. Load deformation tests showed that the composite layer performed far better than the geotextile and geogrid sections and sections with no separation layer. The large-scale laboratory tests were followed by a limited field test of the composite layer with satisfactory performance results.

The composite layer now needs to be tested in a full-scale field setting. The ECM layer can be shipped to the construction site in rolls and can be easily placed by roll-out procedures similar to those used for geotextiles. The investigating team is working with the Illinois Department of Transportation to identify pavement sites during the 1996 construction season. Potential projects for testing include major highway or airport systems, low-volume roads, thin pavement overlays, and railroad track systems. After field verification experiments, a cost-benefit analysis is planned by the investigator to establish the efficiency of ECM pavement layers. The final report is available from the National Technical Information Service (NTIS # PB96-154414).

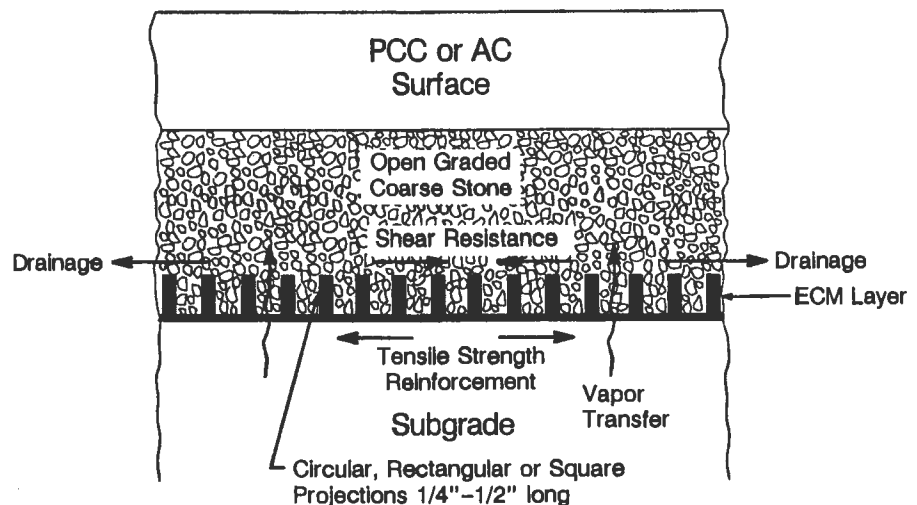

Figure 1

ECM layer concept and functions.

STRATEGY FOR COATING STRUCTURAL STEEL WITHOUT STRINGENT BLASTING REGULATIONS

NCHRP-IDEA Project 7

Simon Boocock [Tel: (412) 687-1113, Fax: (412) 697-1153]

Steel Structures Painting Council, Pittsburgh, Pennsylvania

The project developed and evaluated an environmentally safe technique for applying durable protective paint coating on structural steel without the need for blast cleaning. The concept is illustrated in Figure 1.

The process employed new high penetration primers with low or non-organic volatiles. The paint application technology involved embedding collapsible glass microspheres in the primer, which were then broken to interlock the primer with the topcoat. Fracturing the spheres provides a surface profile that "locks in" the topcoat and ensures a strong bond between the primer and the topcoat. Laboratory tests showed that thermal spray-coating systems employing non-volatile organic compound penetrating sealers loaded with glass microspheres are a viable option for overcoating aged alkyd paints. The addition of glass microspheres to the penetrating primer, however, had no significant effect on the performance of the thermal spray-coating systems.

Microscopic examination of the embedded broken microspheres indicated the potential for enhanced adhesion between the primer and the thermal spray topcoat. The liquid applied topcoat was also found to be a viable option for overcoating aged alkyd systems.

A series of factorially designed laboratory tests was performed in accordance with standard procedures to determine the effectiveness of the coating system regarding adhesion, impact

resistance, and corrosion protection. The results were satisfactory but not significantly superior to the current practice.

The implementation of this new painting process on highway steel bridge structures will require extensive testing in collaboration with state highway agencies. No additional project action is planned by NCHRP-IDEA. The final report is available from the National Technical Information Service (NTIS # PB96-147996).

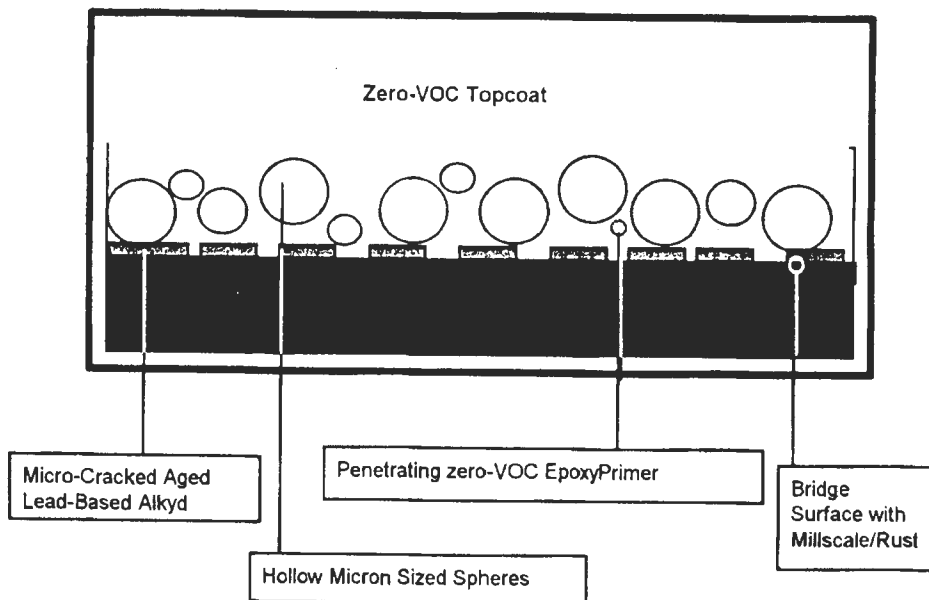

Figure 1

Product applied to bridge use.

CONSERVATION TRAFFIC CONTROL LOAD SWITCH

NCHRP-IDEA Project 8

Gregory A. Filbrun [Tel: (614) 895-1212, Fax: (614) 895-1213], Paul Wiese, and Greg Winthrow, CLS Incorporated, Westerville, Ohio

The project developed and tested a new microprocessor-based switch system (Conservation Traffic Control Load Switch), which significantly enhances the service life of traffic lamps by reducing the initial current surge in the filament coil. The conservation load switch system mitigates early lamp failure by increasing the voltage to the lamp over an 80-msec ramp-up period and then regulating it at a preset level somewhat below the standard line voltage. The prototype switch system was shown to function satisfactorily in the traffic control unit (signal cabinet). The system uses much less (about 30% less) electrical energy to operate the lamp and can be easily retrofitted into existing applicable signal cabinets. It uses the same connector, housing, and mechanical packaging as the standard National Electrical Manufacturers Association (NEMA) Model 170 and Model 200 traffic control load switch units. It can potentially meet all NEMA and Institute of Transportation Engineers (ITE) specifications. The switching system can be installed within a minute in any unmodified signal cabinet (Figure 1).

Operational tests and field evaluations of the switch system were performed. Over 100 units were assembled and sent to a number of state highway agencies for testing. The feedback from highway agencies confirmed the laboratory test results. A continuation project was awarded (NCHRP-IDEA #26) to perform additional field operational tests of the switch system in collaboration with state highway agencies and to develop product transfer and marketing strategies.

A special two-page IDEA product report, *Microprocessor-Based Lamp Switch System Quadruples Traffic Lamp Life and Prevents Early Lamp Burn-out*, was released in September 1995. The final report is available from the National Technical Information Service (NTIS # PB97-143838).



Figure 1

Installation of conservation load switch in standard cabinet.

CORROSION-RESISTANT STEEL REINFORCING BARS

NCHRP-IDEA Project 9

David Darwin [Tel: (913) 864-3826, Fax: (913) 864-3199], Carl E. Locke, Jr., Matthew R. Senecal, Jeffrey L. Smith, and Shawn M. Schwensen, University of Kansas, Lawrence

The project evaluated the corrosion resistance and mechanical properties of steel rebars produced by new microalloying and rolling procedures that exhibit superior corrosion resistance properties. The bars possess a lower carbon content than is usual in U.S. practice and contain copper, chromium, and phosphorus as additional alloying elements. The phosphorus content exceeds that allowed in ASTM specifications. The bars are quenched and tempered immediately after the rolling operation.

Test results (corrosion potential and time-to-corrosion) showed that microalloying decreased the corrosion rate by one-half compared with conventional steel (Figure 1). Quenching and tempering heat treatment in conjunction with microalloying further enhanced the corrosion resistance of steel. The apparent corrosion-resisting mechanisms involve the reduction of microfractures in the surface from the rolling operation due to the quenching and tempering process and the formation of a corrosion-retarding layer of copper chloride-copper hydroxide and iron-chromium oxide at the steel surface. The latter is a poor conductor and thus reduces the corrosion rate. Quenching and tempering had a beneficial effect on the mechanical properties of the steel. Both the yield and tensile strengths were improved. The test results also showed that a phosphorus content in excess of that allowed under current ASTM requirements did not cause the corrosion-resistant steel to be brittle. The new steel also performed well when used in conjunction with epoxy coating.

Extensive field validation tests are required to transfer project results to practice. The results will be presented to ASTM Subcommittee A01.05 on Steel Reinforcement for consideration of specifications similar to ASTM A 615. The final report is available from the National Technical Information Service (NTIS # PB96-147988).

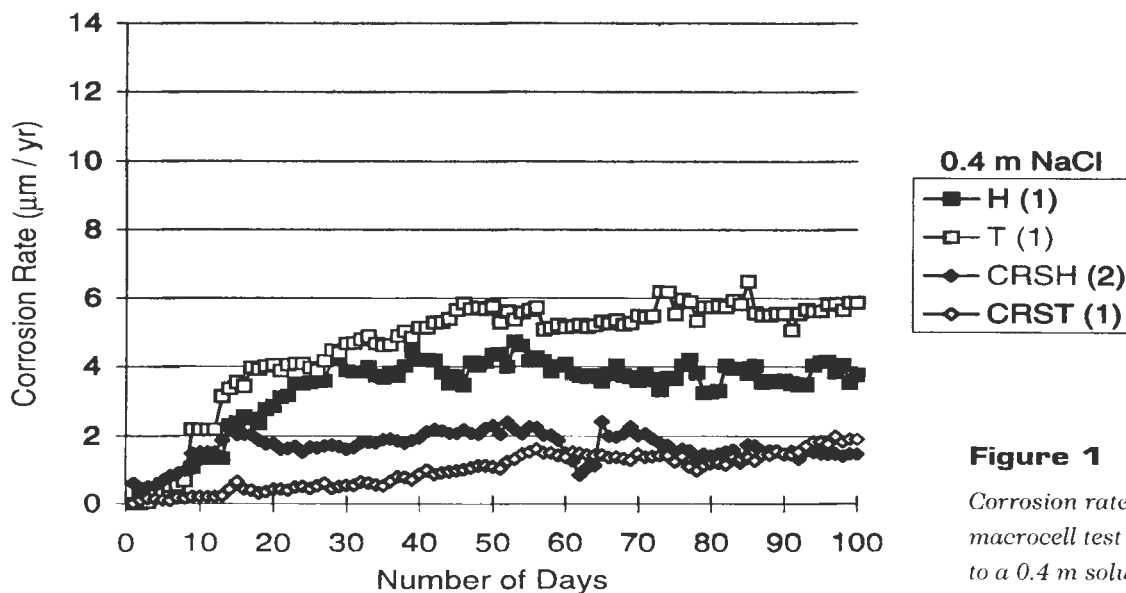

Figure 1

Corrosion rate versus time for macrocell test specimens subjected to a 0.4 m solution of NaCl.

METALLIC COATING FOR CORROSION PROTECTION OF STEEL REBARS

NCHRP-IDEA Project 10

Angel Sanjurjo [Tel: (415) 859-5215, Fax: (415) 859-2111], Kai Lau, David Lowe,
Palitha Jayaweera, and Gopala Krishnan
SRI International, Menlo Park, California

The project was a follow-up investigation from a previous SHRP-IDEA project in which a corrosion-resistant Si-Ti coating on steel rebars was produced using the fluidized bed technology. The current project was intended to scale up the process to coat rebars up to 3 ft long as well as to evaluate the coated rebars for corrosion resistance, structural integrity, flexibility, and mechanical properties.

A bench-scale reactor system was designed for coating 3-ft-long steel rebars. The scale-up reactor system appears feasible but may not be adaptable for commercial scale use. The researchers, however, discovered that a strong and coherent coating could be produced simply by spray painting the Si-Ti mixture (along with a flux) followed by a low-heat treatment at about 600°C (Figure 1). This process appears more practical for scaling up for commercial use than the more complex fluidized bed technology.

Because the paint-and-heat or sprayed coatings are not sacrificial, they will provide much superior corrosion protection for a long time. Corrosion tests showed that these coatings reduced the corrosion rate of steel rebars in chloride environments by over one order of magnitude. The preliminary projected cost for the coating appears similar to that of polymer coatings.

The investigators are working closely with an industrial rebar coater, Western Coating of Oregon. Based on user input, conditions similar to those expected to be found in industrial production are being simulated. A broad user demonstration of the method is also planned by the investigator. The final report is available from the National Technical Information Service (NTIS # PB96-148002).

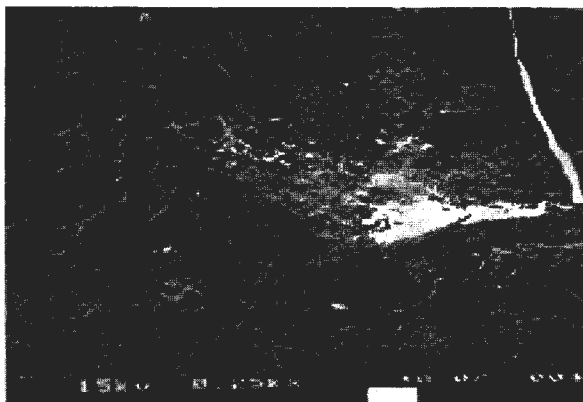

Figure 1

Scanning electron micrograph of coating prepared by paint-and-heat metallization.

REHABILITATION OF STEEL BRIDGES THROUGH THE APPLICATION OF ADVANCED COMPOSITE MATERIALS

NCHRP-IDEA Project 11

Dennis R. Mertz [Tel: (302) 831-2735, Fax: (302) 831-3640], University of Delaware, Newark

This project evaluated the feasibility of using advanced composite materials for rehabilitation of steel highway bridges as an alternative to conventional repair methods. Stage 1 work performed modeling, fabricating, and testing of two flange repair schemes and proved the feasibility of the concept. Service-load testing on the repair schemes verified that the composite plates increased the stiffness of a section. A finite element model was applied to determine the desired geometry of the composite plate. Rehabilitation schemes were developed and tested for a variety of field geometries. Figure 1 shows various rehabilitation concepts. Test results showed good agreement with model prediction for stiffness enhancement. Increases in girder flexural modules of 20% to 30% were found to be attainable, which corresponds to the level of losses expected to be of concern in deficient bridge girders. Sandblasting the steel surface and using a saline pretreatment resulted in best durability for most adhesives. Results also show accelerated bonding through induction heating to be a viable rehabilitation technique in the field. Work in Stage 2 involved additional service load testing of fabricated scale beams, adhesive durability testing, and large scale testing of composite repair of both virgin and corroded steel beams. The results show improved strength and fatigue life of steel components by composite materials. A failure mode of concern is that due to bond failure, which occurred frequently in small tests. This failure, however, did not occur in large girder tests. Field validation of the technique is required for product transfer to practice. This is planned in a follow-up NCHRP-IDEA project in collaboration with the Delaware Department of Transportation. The final report is available from the National Technical Information Service (NTIS # PB97-141964).



Figure 1

Basic rehabilitation geometries.

ADVANCED TESTING OF AN AUTOMATIC NONDESTRUCTIVE EVALUATION SYSTEM FOR HIGHWAY PAVEMENT SURFACE CONDITION ASSESSMENT

NCHRP-IDEA Project 12

Sidney Guralnick [Tel: (312) 567-3549, Fax: (312) 567-3634] and Eric S. Suen
Illinois Institute of Technology, Chicago, Illinois

The project refined and field-tested a prototype nondestructive evaluation system previously developed in an FHWA-sponsored project. The system utilizes the Shadow Moiré interferometry method and measures both vertical surface displacement and changes in slope of surface distress. The IDEA research focused on improving the Shadow Moiré inspection technology and completing a comprehensive user-friendly software package to assess road surface distress. Improvements involved an increase of maximum vehicle acquisition speed of 22%, new light emitters with special horizontal condensers to improve interference fringe pattern contrast, lightweight grating as opposed to two smaller gratings for greater road coverage, and a more accurate distance measuring system. Refinements in post-processing included rewriting C-based image analysis algorithms so that they run under the Pentium personal computer (PC) processor rather than slow video processors. Improvements in image digitization were also realized, such as improved image data integrity and large increases in throughput, allowing for faster post-processing of videotape images.

The prototype road inspection vehicle (Figure 1) was an enclosed uni-axle trailer and was capable of acquiring road surface distress information at velocities up to about 55 mph, allowing users to categorize, rate, and determine roadway locations of all out-of-plane surface deformations along a particular roadway. The cost of the road inspection system is estimated to be about \$60,000.

Ford Motor Company has donated a full-size field vehicle to replace the trailer system for performing field tests. The system is ready for field validation under operational conditions. State agencies and private consulting companies have shown interest in using the system in the field.

A special two-page IDEA product report, *Surface Condition Assessment and Profiler System for Pavements Using Shadow Moiré Interferometry*, was released in June, 1995. The final report is available from the National Technical Information Service (NTIS # PB97-151617).



Figure 1

Automated road inspection vehicle during field testing.

NEW ADDITIVE FOR IMPROVED DURABILITY OF CONCRETE

NCHRP-IDEA Project 13

Jack E. Stephens [Tel: (203) 486-4014, Fax: (203) 486-2298] and James Mahoney,
University of Connecticut, Storrs

James R. Humphrey, Todd Chemical, Cheshire, Connecticut

The project evaluated a class of organic compounds (diammonium salts of alkenyl dicarboxylic acids) as additives for concrete that may improve its durability against freezing and thawing and reinforcement corrosion. The material also reduces heavy metal leachate, potentially making environmentally acceptable the use of incinerator ash (both bottom and fly ash) in concrete.

Freeze-thaw, compression, and indirect tension tests were performed to determine the effect of additives on concrete properties. Porosity and permeability measurements also were done to determine their effectiveness in preventing access of chloride salt solution to the steel. Results showed a rather adverse effect of admixtures on concrete workability and strength. Also, the permeability was not significantly improved. However, the concrete showed excellent freeze-thaw resistance (Figure 1). Furthermore, leaching tests showed that the admixtures significantly decreased the leaching of lead from the concrete. The admixtures have potential to be effective air-entraining agents for concrete for improved freeze-thaw durability. No additional action is planned by NCHRP-IDEA. The final report is available from the National Technical Information Service (NTIS # PB96-147970).

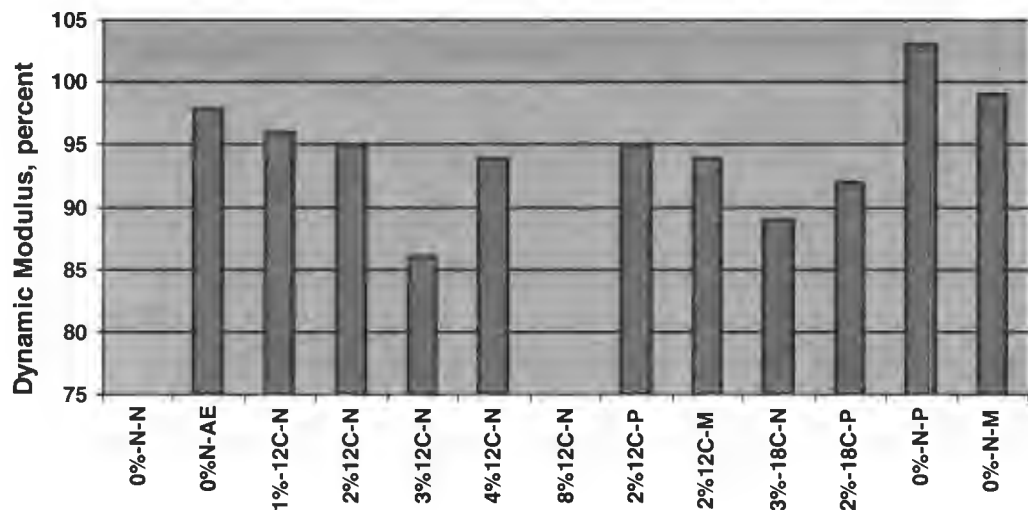

Figure 1

Freezing and thawing test results for concrete specimens containing organic additives.

UNREINFORCED, CENTRALLY PRESTRESSED CONCRETE COLUMNS AND PILES

NCHRP-IDEA Project 14

D.V. Reddy [Tel: (407) 367-3443, Fax: (407) 367-3885],
Florida Atlantic University, Boca Raton

Paul F. Csagoly, Clearwater, Florida

This project tested the concept of centrally prestressed unreinforced concrete (CPUC) columns and piles for application to highway structural systems (Figure 1). In the CPUC column, the innate incompatibility between concrete and steel is eliminated by removal of the latter; but flexural resistance and ductility are restored by the application of a centrally located prestressing tendon or closely spaced strands. This concentration of steel results in a significant increase in concrete cover for better corrosion protection without loss of strength.

Specimens of CPUC columns and piles were evaluated to assess the feasibility and practicality of the concept. Tests (compressive, single load flexural and double load shear) were done to establish the failure modes for prestressed concrete columns and to examine the possibility of restoring the ductility of a reinforced concrete column by replacing conventional reinforcement with central prestressing. Test results showed that the prestressed column provided a substantial increase in effective cross section to withstand both axial and shear loading compared to conventional reinforced concrete columns. Figure 2 illustrates the second innovation, labeled as an extended performance flexural (EPF) device. The EPF device is not a shock isolator, but a completely structural device intended for connecting pier columns to either the superstructure or the substructure, or both, and transmitting considerable moments while permitting large rotations. Performance of the EPF device far exceeded expectations. It sustained several cycles of rotations up to $\pm 10\%$ without damage. Analytical application of the EPF device to a bridge structure indicates close to one order of magnitude increase in the

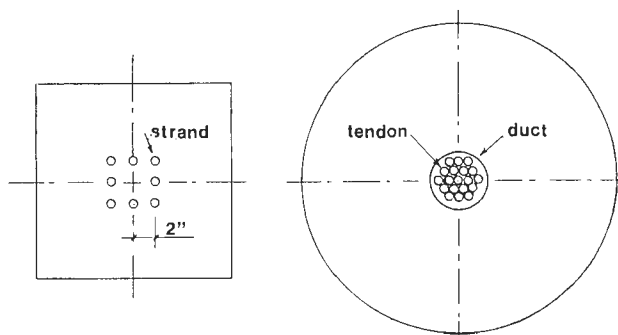

Figure 1

Cross section of CPUC pile and column.

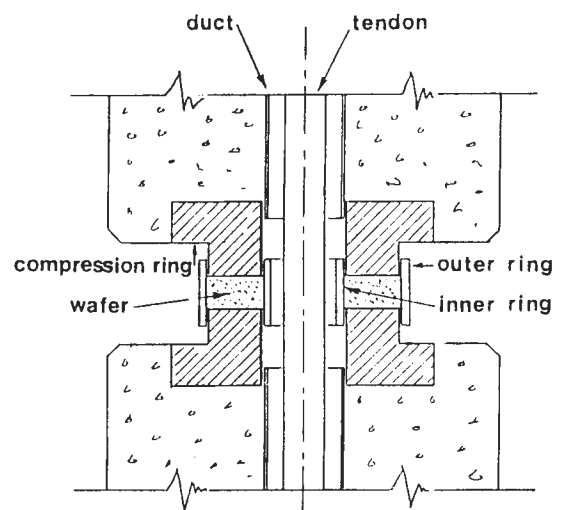

Figure 2

EPF device schematic.

fundamental period of vibration and a decrease of 65% in the equivalent static lateral force used in earthquake design. In summary, the EPF device is capable of both mitigating and resisting earthquake-induced force effects in bridges while protecting the columns against distress of both service and ultimate limit status.

Large-scale field tests involving actual highway structures are being planned in cooperation with CalTrans. The final report is available from the National Technical Information Service (NTIS # PB97-160816).

PORTABLE LASER ROAD CREW WARNING SYSTEM

NCHRP-IDEA Project 15

Keith Higgenbotham [Tel: (703) 367-6838, Fax: (703) 367-2370] and Rudolph Gammarino, Lockheed Martin Corporation, Manassas, Virginia

The project applied a laser technology, previously developed for military application, to develop a portable warning system to improve safety for highway workers. The research identified candidate protection system configurations with attention to reliability, portability, operational range, and effectiveness. The equipment was assembled and successfully tested in the laboratory. The system employs a master laser transmitter, one or more repeater transmitters, optical detector electronics, and a pager transmitter. Each of the repeaters is equipped with a detector that detects and transmits 600 pps to another repeater or to the final optical detector electronics.

The deployment of the road crew warning system is illustrated in Figure 1. The system consists of a battery-powered master laser transmitter mounted on a traffic cone, one or more laser receiver-transmitters also mounted on traffic cones, and a worker notification warning system. A pulsed laser beam from the master laser transmitter is directed toward the laser receiver-transmitter located at the end of taper. The beam is detected by the receiver at that point. The detection event triggers the laser that is co-located with the receiver, and it transmits laser pulses toward a second receiver located at the end of the work zone. The retransmitted beam is received by the final detector at the end of the work zone. If the first beam or the retransmitted beam is interrupted by an errant vehicle at any point, the lack of a laser signal at the final receiver causes an electrical signal to be generated that activates an alarm system,

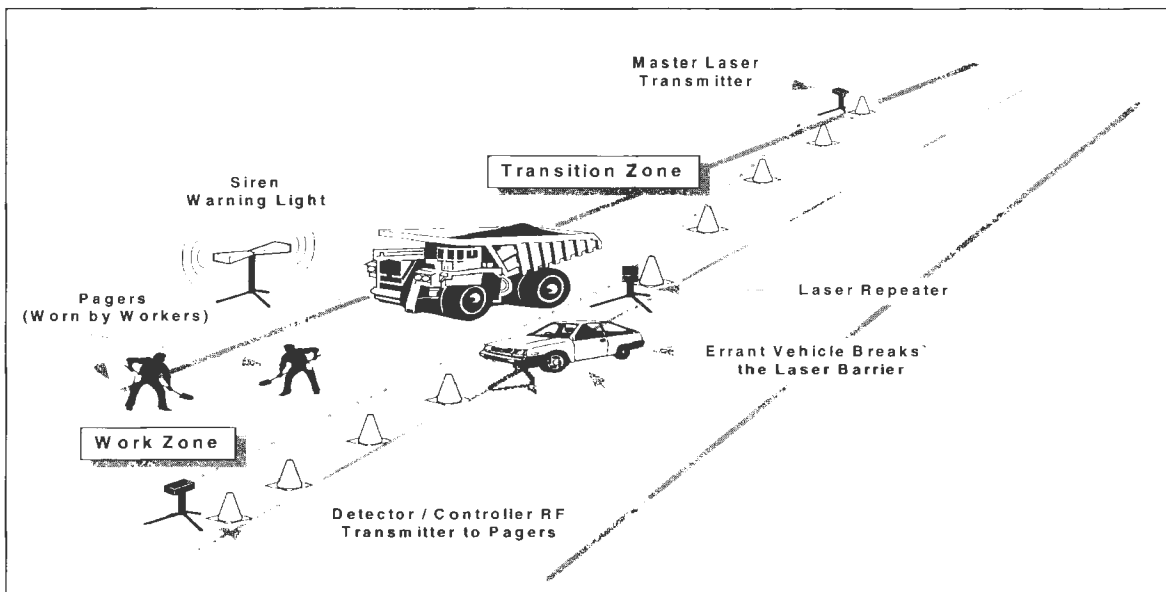

Figure 1

Road crew portable laser warning system.

notifying workers to take evasive action. In this way, the laser beam acts as an electro-optical barrier along the taper and the work zone.

The system configuration can be modified to suit the size and nature of highway maintenance activity. A field demonstration was carried out at the contractor's facility in California with satisfactory performance. The final report is available from the National Technical Information Service (NTIS # PB97-143861).

LASER REMOVAL OF PAINT ON PAVEMENT

NCHRP-IDEA Project 16

Hans Pew and James Thorne, MOXTEK, Incorporated

IDEA Product

A prototype portable laser for removal of paint from paved highways, parking lots, and airfield runways will be developed. Its impact will be (a) the elimination of the usual environmental contaminants such as grit, dust, smoke, and chemicals; (b) prevention of damage to pavement during paint removal; and (c) completion of removal for compliance with federal codes that require no visible trace of temporary markings on newly constructed roadways.

Concept and Innovation

Lasers typically remove paint by heating, charring, and slow burning with air or an oxygen jet. Another approach is the use of a succession of short, intense, laser pulses that create destructive shock waves rather than heating to the point where chemical reactions occur and smoke is generated. Several brands of lasers were tried in the laboratory to demonstrate such removal.

IDEA Project Investigation and Progress

Laboratory results showed that removal was clean, but not fast. The best criterion for rating laser performance is the volume of paint it removes per second. This depends primarily on five factors: 1) the energy per pulse, 2) the duration of each pulse, 3) the number of pulses per second, 4) the depth of paint removed per pulse, and 5) the area of paint irradiated by each pulse.

The maximum energy per pulse and the number of pulses per second should be maximized, and this suggests the use of a very large laser. However, beyond about 25 watts of average power in the light beam, initial costs become prohibitive. In addition, the bulk and maintenance of large lasers hinder their use in this application. There is every reason to believe that diode-pumped lasers will be smaller and more powerful in the near future, but a careful search found none currently available in the range of power needed. Lasers driven by flash lamps will continue to be used until diode-pumped lasers meet the criteria of cost and effectiveness.

The investigators previously reported on a number of experiments that provided information on the depth of paint removed by each pulse as a function of the area of irradiation for two lasers: the Coherent Infinity laser and the Instamark Elite laser system. These will now be compared to recent experiments with the CFR-800 laser at the Blue Sky Laser Technology applications laboratory. While there, we irradiated marking materials including lacquer (Bauer UN1263) and cold polymer. Measurements to some marking materials not previously studied by the investigators, namely hot polymer and epoxy, were also included. The results are shown in Table 1.

TABLE 1. Results of laboratory laser tests on ablation of various markings.

Paint	Substrate	Laser	Shots	Diam, cm	Ablation, cm³/kJ	Notes
LacquerU N1263	Concrete	CFR 800	2	0.7	362	Becomes resistant
LacquerU N1263	Concrete	CFR 800	10	0.7	86	Somewhat erratic
LacquerU N1263	Concrete	Coherent Infinity	52	0.71	104	Thick paint
LacquerU N1263	Asphalt	CFR 800	5	0.95	140	Paint bonded poorly
LacquerU N1231	Asphalt	Lumonics CO2	10	0.5	Very low	Almost no ablation
Epoxy	Concrete	CFR 800	10	1.35	492	High MW/cm ² threshold
Cold Polymer	Sheet	CFR 800	5	1.2	195	Softens at high rep rates
Hot Polymer	Sheet	CFR 800	2	1.25	190	Softens at high rep rates

The maximum depth of removal per pulse was between 20 and 95 μ m in each of the materials. Surprisingly, the epoxy paint was removed with better efficiency than the others. This was attributed to the rigidity and brittleness of the epoxy, which promotes efficient shock propagation and cracking. The other polymeric materials are typically not densely crosslinked, and they contain small voids as do most linear, glassy polymers. The investigators suggest that this structure weakens the shock wave, and that it converts a larger fraction of the shock energy to heat than the epoxy does.

Plans for Implementation of IDEA Results and Product

The funding for this contract was insufficient to purchase a laser for installation on the mobile unit; however, Spectra Physics Corp. has agreed to attach one of their larger lasers to the mobile carriage in their laboratory. It will be operated there to ablate paint while being videotaped. The tape and experimental results will be used to convince one or more distributors to buy a laser for a demonstration unit that can be shown to prospective customers. Plans for the manufacture and sale of production units for paint ablation are being arranged.

SELF-CONTAINED PORTABLE DEVICE FOR SHRP BINDER TESTING: FIELD QC/QA TESTING WITH THE DUOMORPH

NCHRP-IDEA Project 17

Samuel H. Carpenter [Tel: (217) 333-4188, Fax: (217) 333-9464], University of Illinois, Urbana-Champaign

The project developed a portable field device (Duomorph) for testing asphalt binder properties that will complement the SHRP (Strategic Highway Research Program) dynamic and bending beam rheometers. Figure 1 shows typical Duomorph assemblies. The research was intended to improve and refine Duomorph technology by using new piezoelectric materials, sensors, improved digital technology, newer electronic equipment, and finite element modeling to make and validate a self-contained portable device for field use at temperatures ranging from -28°C to $+80^{\circ}\text{C}$, the Superpave range of temperature. In Stage 1, a Duomorph testing system (Duomorph Asphalt Rheology Test or DART) was assembled and shakedown tests were performed in the laboratory using SHRP reference asphalt binders. The tests have demonstrated that the DART system is durable and provides data that compare well with standard SHRP equipment. A 2-inch gauge size appears satisfactory for testing. Stage 2 work performed a functional testing system and extensive experimentation to establish operational characteristics at various temperatures as required in SHRP binder specifications. A supplemental award (NCHRP-IDEA Project 41) has been made for further refinement of the device and for fieldtesting and demonstration to state highway agencies. The final report is available from the National Technical Information Service (NTIS # PB97-143879).

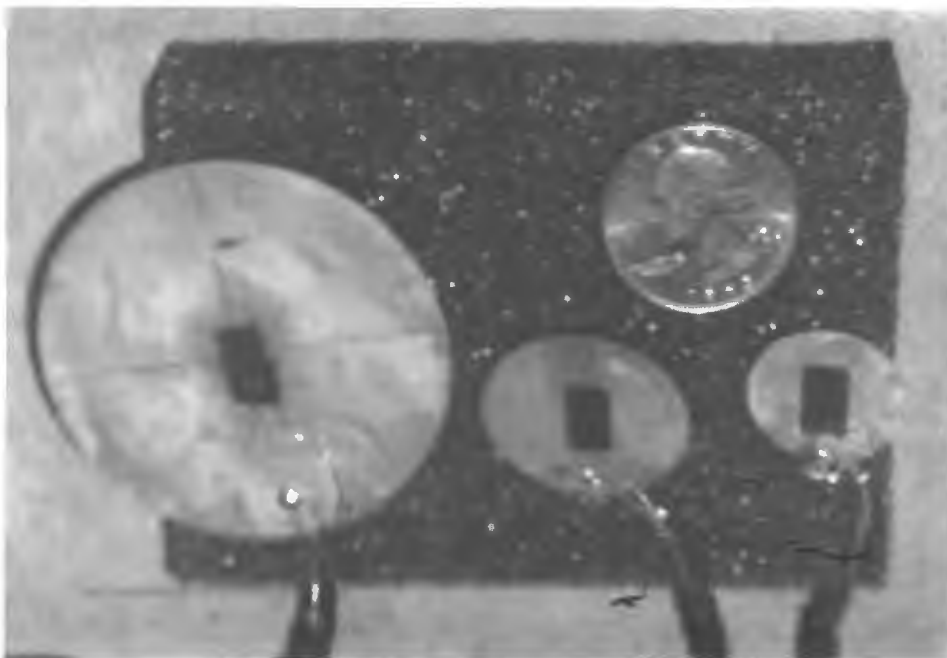

Figure 1

Duomorph assemblies.

NEW PRINCIPLES OF DESIGN FOR CUTTING TOOLS TO REPAIR AND REMOVE PAVEMENTS BASED ON THE EFFECT OF LATERAL PROPAGATION OF CRACKS UNDER CONTACT LOADING

NCHRP-IDEA Project 18

Igor Sveshnikov [Tel: +7 (044) 263-84-07, Fax: +7 (044) 265-09-95],
POTOK Centre, Kiev, Ukraine

This project developed tool designs for energy-efficient cutting and removal of concrete pavement. The concept takes advantage of the lateral propagation of cracks in concrete produced by using indentors with unconventional asymmetric geometric shapes (Figure 1). The production of lateral cracks in hard rocks facilitates the breaking and removal of material with reduced energy consumption and improved efficiency and productivity. The effectiveness of various indenter configurations was investigated for crack initiation and propagation in rocks, such as limestone, and model materials, such as unreinforced optical glass. Results of theoretical modeling and experimental tests show that cutters with an asymmetric elliptical insert are most effective in producing cracks and breaking the rocks with considerably reduced energy consumption. Based on theoretical and experimental work, the tool designs were developed and prototypes were fabricated and delivered.

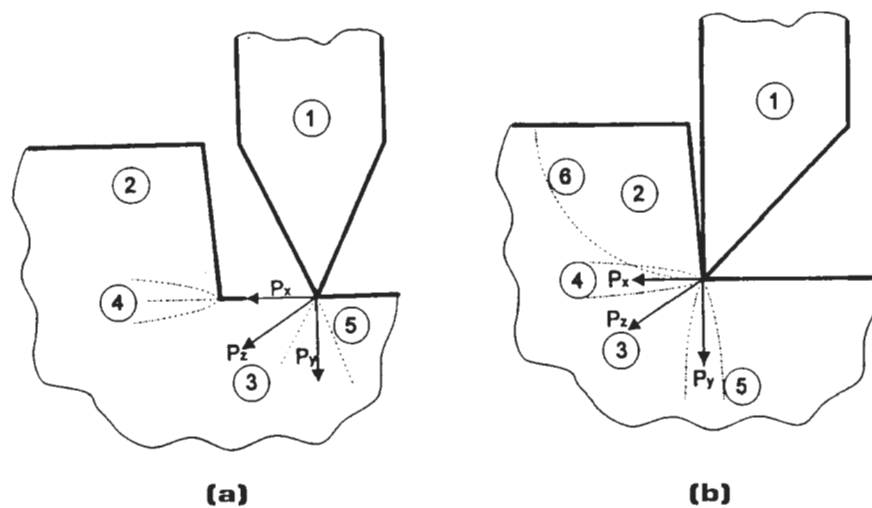

Figure 1

Crack propagation of friable material under contact of (a) indenter of traditional shape and (b) indenter of special shape (1, cutter; 2, rock; 3, element of cutting strength; 4, system of subhorizontal cracks; 5, system of vertical cracks; 6, trajectory of rock mass destruction).

ALUMINUM BRONZE ALLOY FOR CORROSION-RESISTANT REBAR

NCHRP-IDEA Project 19

David Stein [Tel: (817) 473-1996, Fax: (817) 463-1997],
Man-Tech Development, Inc., Mansfield, Texas

This project evaluated aluminum bronze alloy as a possible alternative to steel for corrosion-resistant concrete reinforcement. Rebars from aluminum bronze alloy were fabricated for laboratory and field evaluations. Initial tests showed rather low mechanical properties for alloys as compared to steel. Further work focused on improving the strength and mechanical properties of the alloy by optimizing its composition and fabrication process. The process eliminated the hot rolling operation and entailed direct continuous casting of aluminum bronze to a near net size and shape of rebar followed by cold drawing the bar to finished size and shape. The cold drawing operation increased the strength of aluminum bronze rebars close to that of mild steel rebar, meeting the ASTM specifications (Figure 1). In corrosion tests, the aluminum bronze alloy showed high resistance to seawater corrosion as compared to mild steel and ductile steel (Figure 2). Cost analysis of aluminum bronze rebars showed a cost of \$0.85 per lb. as compared to \$1.20 per lb. for stainless steel at current metal prices. The final report is available from the National Technical Information Service (NTIS # PB97-141972).

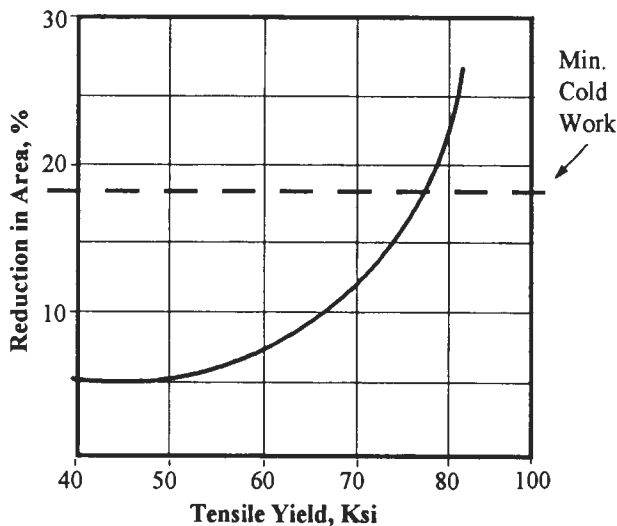

Figure 1

Tensile yield strength of aluminum bronze as a function of strain hardening.

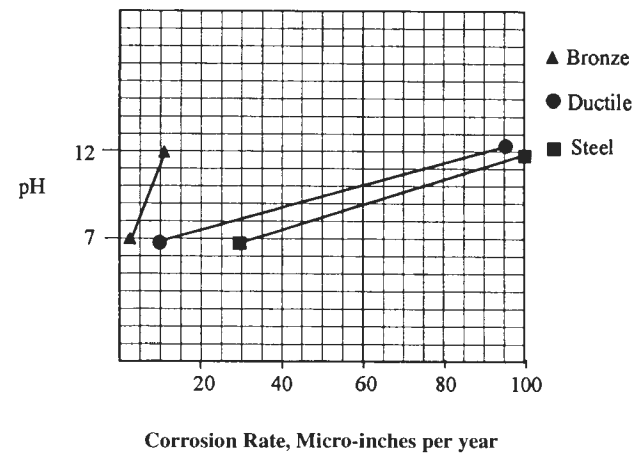

Figure 2

Corrosion rates of three alloys to chloride ion corrosion.

CARBON DIOXIDE (DRY ICE) CLEANING TO REMOVE HIGHWAY ROAD MARKINGS AND STRIPES

NCHRP-IDEA Project 20

Andrew W. Pazahanick [Tel: (800) 832-4262, Fax: (404) 985-9179],
Tomco Equipment Company, Loganville, Georgia

The project explored a new process of pavement paint removal using CO₂ pellets. CO₂ is formed into small, dense dry ice pellets (approximately 3 mm in diameter), which are then accelerated to a painted surface for cleaning markings on highways.

The cleaning system uses either air or an electric motor to propel the dry ice pellets. The dry ice pellets are accelerated from the CO₂ cleaning system through a gun-like nozzle attached to a single hose (Figure 1).

A centrifugal CO₂ cleaning system was developed that propelled the dry ice pellets at a significantly higher rate than the pneumatic CO₂ cleaning system.

The results from the pneumatic CO₂ cleaning system appeared to be very good on core samples. However, it was impracticable to use a 2-inch nozzle to remove road marks and stripes on highways. In addition, the exit pattern from the centrifugal system must be designed for removing various sizes of road markings and stripes.

The test results, however, show that the process works for cleaning road markings and stripes. CO₂ cleaning

can, therefore, be used to restore the brilliance and extend the life of markings and stripes by removing a very fine layer from the top of the existing markings and stripes. In addition, it can be used to remove temporary road markings and stripes.

The consumption rate of dry ice pellets was approximately 150 pounds per hour with the pneumatic system. At this rate, if cleaning could be accomplished on one pass, CO₂ cleaning would be cost-effective as compared to burning or grinding markings and stripes. CO₂ cleaning is an environmentally safe process and reduces waste by not adding any secondary waste to the cleaning process.

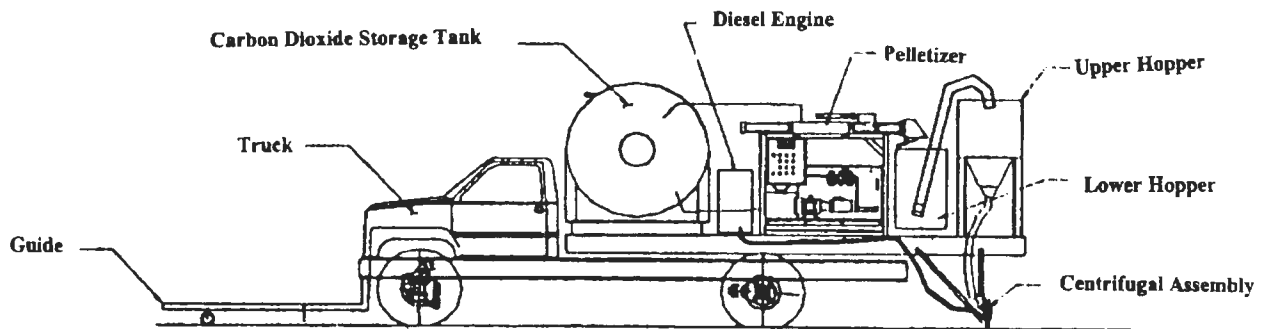

Figure 1

Drawing of proposed centrifugal transport.

Tomco is working with the Georgia Department of Transportation to develop a CO₂ cleaning system to clean at 5 mph. The pneumatic CO₂ cleaning system was slower than 5 mph. The feed mechanism and nozzle must be improved for the commercial design of a CO₂ cleaning system. Further testing of the effectiveness of cleaning road markings and stripes is also needed.

DEVELOPMENT OF LED LIGHT SOURCE FOR TRAFFIC CONTROL DEVICES

NCHRP-IDEA Project 21

Mark Finkle [Tel: (814) 355-4479, Fax: (814) 355-5817],
The Last Resource, Inc., Bellefonte, Pennsylvania

This project produced a multi-use light-emitting device with delineation and warning capabilities based on light-emitting diode (LED) technology (Figure 1). The LEDs have a much longer life span than conventional lamps and require less power to operate. The internal light source can be placed in different types of housings that would allow the device to be used as a delineator, raised pavement marker, or steady-burn/flashing warning light. The result is a device that requires less maintenance and is more flexible in its use. The development of a prototype traffic control device (TCD) involved design and construction of the internal hardware for the LED light source and different types of housing required for the TCD system. Results based on accelerated testing show that the LED light source concept works as expected and produces significant gains over conventional light sources (Figure 2). The system now needs to be tested by state highway agencies.

The commercialization of the IDEA product is being explored. Various TCD manufacturers are being contacted. Because the light source and power controller are separate modules, that application of the active power management may be more attractive to manufacturers than the complete product. The final report is available from the National Technical Information Service (NTIS # PB97-143846).



Figure 1

High- and low-intensity LED devices.

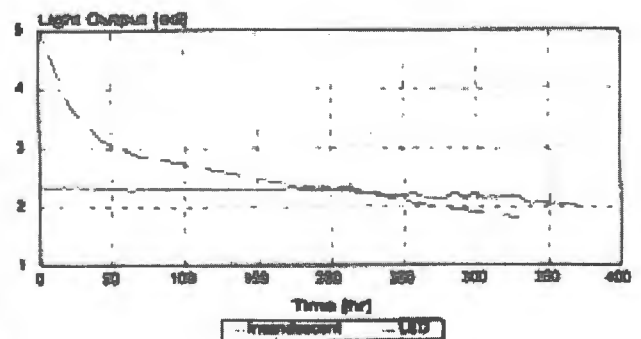

Figure 2

Results of endurance testing.

USE OF PHASE CHANGE MATERIALS TO PREVENT OVERNIGHT FREEZING OF BRIDGE DECKS

NCHRP-IDEA Project 22

Ival Salyer [Tel: (543)229-2654, Fax: (543) 229-4251],
University of Dayton Research Institute, Dayton, Ohio

This project evaluated a class of polymeric materials (linear crystalline alkyl hydrocarbons) that stored and released heat energy as a result of phase change in freezing temperatures for use in concrete to prevent overnight freezing of bridge decks. The phase change materials were encapsulated in high density polyethylene pellets and either mixed with or installed around concrete to provide heat energy. Modeling verification of the thermal response of bridges and roads under varying climatic conditions and with various phase change materials and application methods was performed. This was followed by laboratory tests and limited field evaluation to establish material performance and effectiveness in the highway freeze-thaw environment.

The test results show that the addition of phase change materials to the concrete prevented freezing on the surface (Figure 1). However, the addition of the materials also decreased the conductivity of concrete slabs, which slowed its warming and also adversely affected the performance of phase change materials. Placing the material at the bottom of the concrete slab delayed the cooling of the slab top surface. It also slowed its warming, which was not desirable. Darkening the top surface had a beneficial effect on the slab surface temperature. The final report is available from the National Technical Information Service (NTIS # PB97-143820).

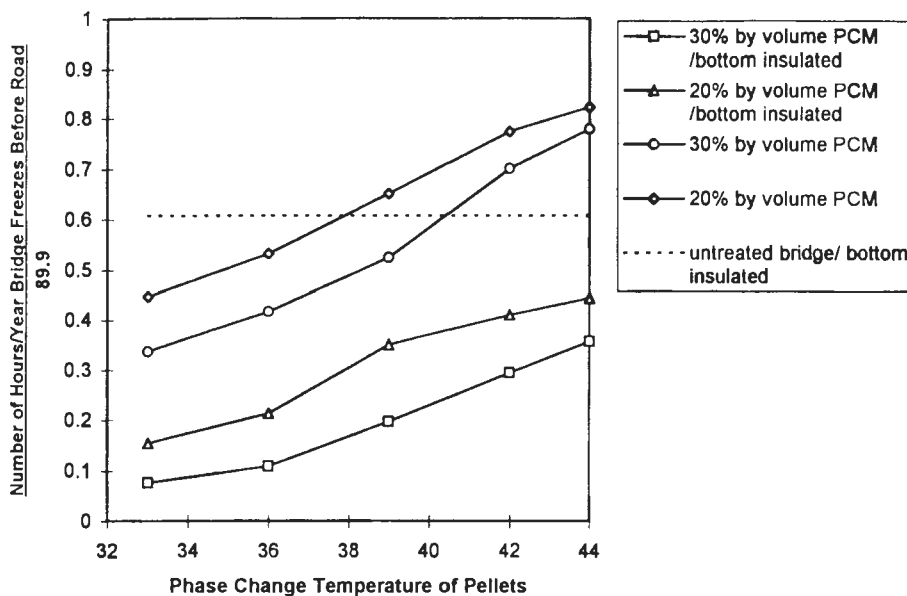

Figure 1

Hazard reduction as affected by phase change temperature for an 8-inch-thick deck with phase change material pellets in the top half.

LEAD-BASED PAINT REMOVAL FROM STEEL STRUCTURES

NCHRP-IDEA Project 23

Rudolf Keller [Tel: (412) 325-3260, Fax: (412) 335-8402],
EMEC Consultants, Export, Pennsylvania

This project evaluated an electrochemical cathode debonding process for stripping paint from highway steel structures (Figure 1). The method eliminates airborne paint particles and is a viable alternative to the common abrasive blasting of lead-based paint. In addition, toxic lead components can be collected and recycled. Laboratory tests were carried out to determine concept feasibility and optimize process parameters. The process effectively debonded and removed paint from steel surfaces in 1 to 2 hours using 10-cm x 10-cm electrolytic patches under a constant voltage of 8 to 12 V and a current of 7.5 A or less. A prototype paint removal equipment system was designed for larger-scale testing.

After additional process optimization in the laboratory, small-scale field tests on highway bridges and steel structures were performed to establish the application's feasibility in actual highway structures (Figure 2). The field work shows promising results. Some initial surface preparation may be necessary to initiate the process. A supplemental IDEA award was approved for full-scale field demonstration of the technology on highway bridges in collaboration with the Virginia Department of Transportation (NCHRP-IDEA #38). The final report is available from the National Technical Information Service (NTIS # PB97-141980).

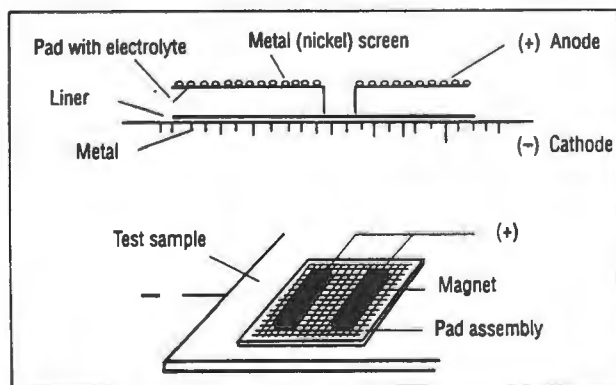

Figure 1

"Electric blanket" used for electrochemically assisted paint removal.



Figure 2

Field testing of process at bridge in Pennsylvania.

FIBER-OPTIC STRAIN SENSOR SYSTEM FOR LONG-TERM MONITORING OF HIGHWAY STRUCTURES

NCHRP-IDEA Project 24

Ken Lou [Tel: (602) 730-4446, Fax: (602) 893-8643],
Simula Government Products, Inc., Phoenix, Arizona

The project investigated the feasibility of a fiber-optic (FO) strain sensor system for long-term monitoring of highway structures. The principle of operation relies upon measuring the time-of-flight of an optical signal's propagation through an optical fiber and then converting it to mechanical strain. By segmenting an optical fiber string with optical reflectors, the strain of in-line segments can be determined separately. This method enables strain mapping of an entire structure with a finite-element sensor grid and is capable of detecting localized damage such as cracking and stress corrosion. The monitoring system includes a high-resolution optical time domain reflectometer (OTDR), FO data acquisition (FODAC) software, and FO strain gauge patches (FOSGPs), which allow monitoring of integral strain in large structures (Figure 1). The FOSGPs are flexible sensor patches that can be embedded in or attached to the structure to be monitored.

Tests with steel and composite coupons showed that, using the latest OTDR, the FOSGP sensors achieved a resolution of 0.01 percent strain and could resolve tensile strain in reinforced concrete just before failure due to fracture.

The sensitivity of the FOSGP sensor appears to be limited by the OTDR system. Also, the potential to multiplex patches in-line (to interrogate multiple locations) was limited because of increased attenuation of the FO sensors by the glass-reinforced epoxy carrier material. For the time delay strain measurements to be practical for structural monitoring, OTDR accuracy must be improved to at least better than 3.0 ps. The smaller 3-m patches may be multiplexed, but would require an OTDR with a resolution of better than 1.0 ps. The sensors appear to be most successful at detecting strain if placed at compression locations on concrete structures. Because of the limitations of the current OTDR system in achieving accurate measurements and the limitations of the type of optical fiber used in the concrete environment, no field demonstrations were conducted. The final report is available from the National Technical Information Service (NTIS #PB 98-139074).

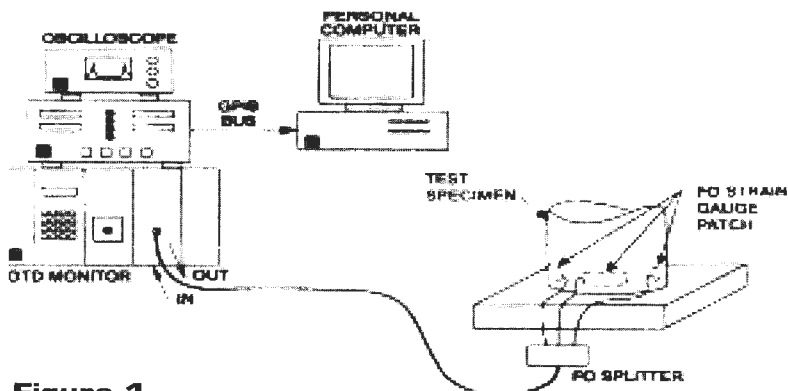

Figure 1

Fiber-optic sensor data acquisition system.

BASALT FIBER COMPOSITE REINFORCEMENT FOR CONCRETE

NCHRP-IDEA Project 25

V.B. Brik [Tel: (608) 244-1349, Fax: (608) 244-9071],
Research and Technology, Inc., Madison, Wisconsin

This project explored the feasibility of using rebars made from braided basalt fiber strands as concrete reinforcement (Figure 1). The material is expected to be a low-cost, high-strength, high-modulus, and corrosion-resistant alternative to steel for concrete reinforcement. The basalt fibers were produced using a process developed in Ukraine. Several types of basalt fibers were procured from Ukraine and evaluated for strength, brittleness, and tensile properties. A continuous basalt fiber, 9 to 15 mm in diameter, was determined to be most suitable for rebar fabrication. The rebars, consisting of about 80% to 90% fibers and an organic binder, were fabricated and tested for mechanical properties (strength and modulus) and corrosion resistance. Test results established the suitability of basalt composite rebars for use as concrete reinforcement (Table 1).

A supplemental IDEA award for large-scale and field operational testing of basalt rebars as concrete reinforcement was approved (NCHRP-IDEA 45). The final report is available from the National Technical Information Service (NTIS # PB97-161335).

TABLE 1. Mechanical Test Data for Epoxy-Bonded Basalt Fiber Composite Specimens.

Specimen No.	Width (mm)	Thickness (mm)	Failure Load (pounds)	Ultimate Strength (psi)	Elastic Modulus (msi)	Poisson's Ratio
1	25.0	3.3	10,340	83,738	4.52	0.128
2	25.0	3.3	10,340	83,738	4.52	0.128
3	24.8	3.1	10,512	37,745	5.40	0.205
4	24.8	3.2	10,040	81,558	4.61	0.210
5	25.0	3.3	10,368	83,952	4.98	0.177

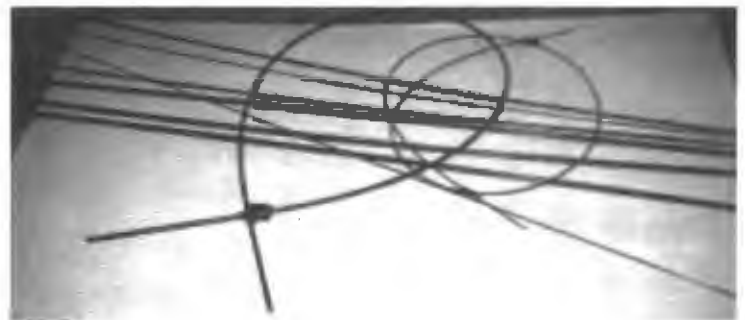

Figure 1

Basalt fiber composite rebars.

CONSERVATION CONTROL LOAD SWITCH OPERATIONAL TESTS

NCHRP-IDEA Project 26

Greg Filbrun [Tel: (614) 895-1212, Fax: (614)895-1213], CLS, Inc., Westerville, Ohio

This is a follow-on project for a previous IDEA project (NCHRP-IDEA Project 8) to perform field operational testing of an improved conservation traffic control load switch system. This microprocessor-controlled switch system extends the life of incandescent traffic lamps by reducing the initial current surge in the filament coil switch system. The project developed a manual for installation and operation of a conservation traffic control load switch system. About 100 units were assembled and provided to state highway agencies for evaluation. Based on the feedback from highway agencies, the switch housing design was modified. The Institute of Transportation Engineers (ITE) and the National Electrical Manufacturers Association (NEMA) specifications were met and NEMA certification of conformance for the switch system was completed. The device is mechanically compatible with NEMA model 200 cabinets and, with minor housing adjustment, also with 170 signal cabinets.

Figure 1 compares historical and expected lamp maintenance expenditures for a standard three-lamp signal head and a three-lamp signal head using the IDEA product. The contractor is

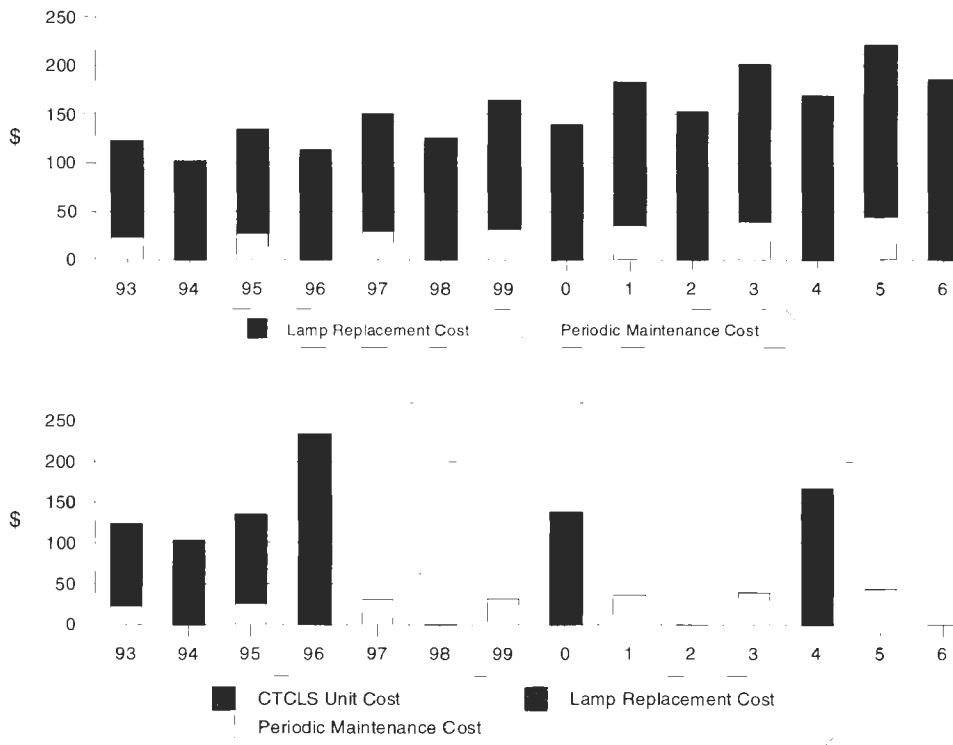

Figure 1

Historical and expected lamp maintenance expenditures. Top: Standard three-lamp signal head. Bottom: Three-lamp signal head using the IDEA product. Both graphs are based on a 1995 lamp-replacement cost of \$38 per lamp with a 5% increase per year, and CTCLS unit cost of \$119. Biannual periodic maintenance is also shown.

now focusing on commercial production and sales strategies for the switch system. Manufacturing and sales relationships with users are being established. Approximately 100 local, municipal, and state highway agencies as well as some from foreign countries are participating in this study and are watching the IDEA product under field operational conditions. The contractor marketing strategy incorporates plans to sell the product through several available marketing channels. The final report is available through the National Technical Information Service (NTIS # PB97-143853).

AUTOMATED BRIDGE DECK ANTI- AND DEICING SYSTEM

NCHRP-IDEA Project 27

Rand Decker [Tel: (801) 581-3404, Fax: (801) 585-5477], University of Utah, Salt Lake City

This IDEA project started in March 1996 and was completed in June 1998.

The IDEA project advisor is Larry Frevert, Department of Public Works, Kansas City, Missouri.

This project developed and tested an automated bridge deck anti- and deicing system. The system uses accepted liquid freezing point depressants, such as NaCl brine or liquid $MgCl_2$, and traditional spray application techniques coupled with a modern roadway weather information system (RWIS) and novel data communication and process control to perform the task. Fixed snow and ice control systems are used in Western Europe to spray bridges with liquid snow and ice control materials at a number of sites. The system improves European practices and adapts them to U.S. highway practice.

The innovative element of this system, which is based on traditional hydraulic components, includes the provision for automated process control. The decision to apply anti- and deicing fluid to the bridge can be controlled by a knowledge-based algorithm (figure 1), initialized on a process control computer located at the bridge. The process control algorithm uses data from the sensors of a modern RWIS. In addition, system status checks and manual operations may be carried out remotely using a cellular phone and voice/keypad menu commands. The anti- and deicing process can be initiated from the cab of a vehicle located at the bridge. This project addresses real-time bridge conditions, incident data acquisition and management, traffic safety, and support of intelligent transportation systems.

A prototype automated bridge anti-icing system was designed for and installed at the 6200 South Street overpass of I-215 in suburban Salt Lake City, Utah.

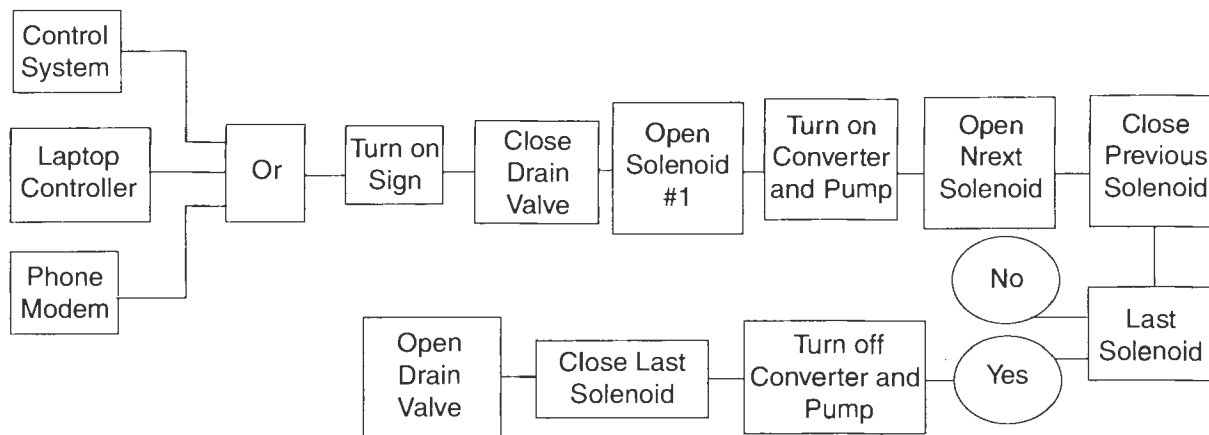

Figure 1

Spray system controller flowchart.

After successful field tests, operations of the system was adopted on this curved section bridge.

A field operations program to implement the IDEA program is under way in cooperation with the Federal Highway Administration (FHWA); Maintenance Specialties, Inc., of Salt Lake City, Utah; Surface Systems, Inc., of St. Louis, Missouri; the Winter/Alpine Program Laboratory, University of Utah; and the Washington State Department of Transportation (WSDOT).

The field installation sites chosen for the Washington project are WSDOT bridge #12/810, the Stember Creek bridge of USR 12 in remote southeastern Washington; and WSDOT bridge #97/2, the Burlington Northern Railroad (BN RR) overpass of USR 97 in the Columbia River gorge.

The American Public Works Association, the British Ministry of Highways, the Kansas City Department of Public Works, the Japan Ministry of Construction, the Nevada Department of Transportation, and the Priority Technologies Project Office of FHWA have shown interest in using the system for road applications.

CORROSION-RESISTANT LOW-CARBON STEELS FOR CONCRETE REINFORCEMENT

NCHRP-IDEA Project 28

Gareth Thomas [Tel: (510) 486-5696, Fax: (510) 653-0965], and David Trejo,
University of California, Berkeley

This project designed and produced dual-phase ferritic martensitic (DFM) reinforcing steel with improved mechanical properties and corrosion resistance. DFM steel is a low-alloy, low-carbon steel produced by simply quenching the alloy from the two-phase ferrite/austenite field, thus producing a mixture of ferrite and martensite. The major strength source in the DFM structure originates from the presence of the inherently strong martensite phase, which provides the load-carrying constituent of the alloy. The soft ferrite phase provides the alloy with ductility.

Electrochemical evaluations were performed for in situ and ex situ conditions. The ex situ electrochemical test results provided different conclusions on the performance of the reinforcing steels. Anodically polarizing the steels in a de-aerated, decanted cement solution with 3.5% NaCl indicated that the DFM steel is more resistant to corrosion (Figure 1), while the ASTM A615 steel shows substantial corrosion products from the exposure. ASTM G-61 results indicate that the DFM steel is more susceptible to chloride-induced localized corrosion in the decanted, de-aerated cement solution. The ASTM G-61 results did not correlate with the in situ testing results and further investigations are required to determine these discrepancies.

In situ testing included Lollipop mass loss testing, Southern Exposure macrocell current testing, and Southern Exposure mass loss testing. All in situ tests indicated that the DFM reinforcing steel was more resistant to chloride-induced corrosion when embedded in concrete than commercially available reinforcing steels. The investigator is negotiating with Nucor Steel, a steel manufacturer, for production of a 50-ton heat of DFM steel. Since Nucor Steel does not have an on-line quenching, the steels must be heat treated following rolling. Bars from Nucor will be tested for mechanical and conversion properties. The final report is available from National Technical Information Service (NTIS #PB-139060).



Figure 1

ASTM A615 and DFM steels after ex situ imposed polarization testing.

SUPERELASTICITY-BASED MATERIALS FOR BRIDGE REHABILITATION

NCHRP-IDEA Project 29

Jer-Wen Hsu and Ken Ostowari [Tel: (517) 349-5653, Fax: (517) 349-5653],
 DPD, Inc., Lansing, Michigan
 Parviz Souroushian, Michigan State University, East Lansing

The project developed and demonstrated the application of superelastic shape-memory alloys for the rehabilitation of bridge structures. These materials undergo phase transformation under stress and, after an apparent plastic deformation, return to their original shape when heated (Figure 1). A nickel-titanium-chromium alloy was selected and optimized based on strength and elongation capacity requirements. Structural design procedures for rehabilitation based on superelastic post-tensioning systems as well as rehabilitation schemes using shape-memory and superelastic alloys were developed. Results of tests on concrete beams demonstrated the effectiveness of rehabilitation by shape-memory reinforcement in eliminating excess deformations and crack widths after failure. The beams satisfied all the serviceability and strength requirements under twice the original live load after they were repaired. Work on using superelastic (in place of shape memory) reinforcement for rehabilitation showed that the superelastic reinforcement was able to recover up to 8% strain, which is estimated to be adequate for self-repair after substantial cracking and deformation. The superelastic reinforcement system was also processed into polymer matrix composite sheets and glued onto concrete structures for rehabilitation and self-repair. Testing verified applicability of the composite system to the self-rehabilitation technology. Large-scale demonstration of the rehabilitation technology in collaboration with the Michigan DOT is being performed in a follow-up IDEA project. The final report is available from the National Technical Information Service (NTIS #PB98-13508).

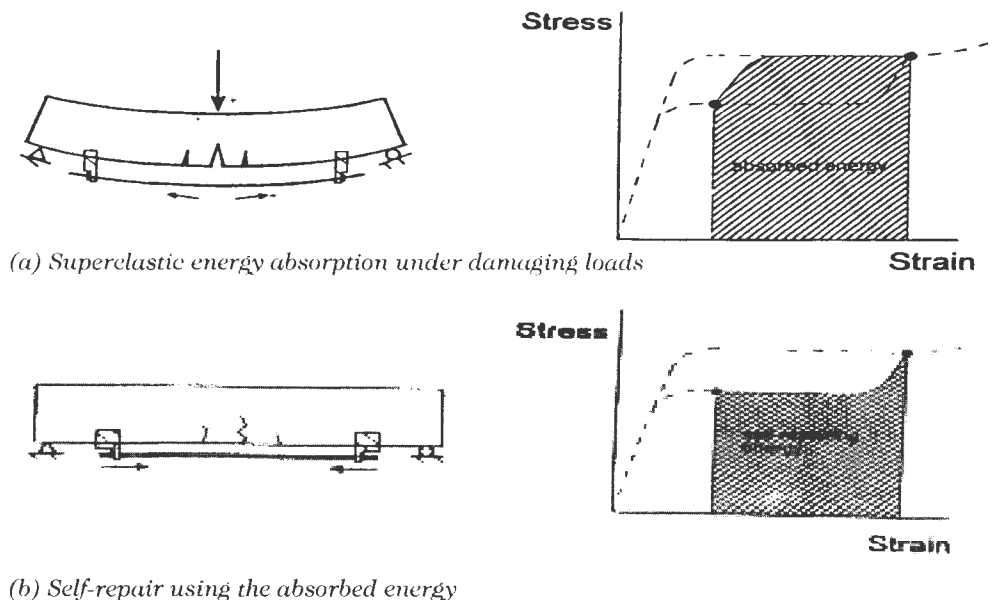

Figure 1

Schematics of the superelasticity-based post-tensioning system.

RAPID REPLACEMENT COMPOSITE BRIDGE NO. 1

NCHRP-IDEA Project 30

Jerry D. Plunkett [Tel: (913) 483-2589, Fax: (913) 483-5321],
Kansas Structural Composites, Inc., Russell, Kansas

This project designed, fabricated, and tested a lightweight composite bridge made of fiberglass-reinforced polymer honeycomb structural panels. The composite bridge was designed in accordance with U.S. Highway Bridge Code HS-25. The key strength requirement was that the span to deflection ratio be 750 under a 40,000-pound load. The bridge was constructed over No-Name Creek in Russell County, Kansas, using three fiberglass honeycomb panels with interlocking edges. Each panel was about 23 feet long and 9 feet wide. The bridge installation time was less than 6 hours. The bridge performance was tested by driving heavy vehicles onto the bridge panels and measuring the deflections (Figure 1). The performance measurements were within the bridge code requirements. The bridge is now open to traffic. A ribbon-cutting ceremony was performed in December 1996. A supplemental award (NCHRP-IDEA Project 46) has been made for preparing specifications and guidelines for installing the composite bridge and field evaluating the honeycomb panels in bridge decks on highway bridges in Kansas in coalition with the Kansas Department of Transportation. The final report is available through the National Technical Information Service (NTIS # PB97-201511).



Figure 1

Composite bridge under test in Russell, Kansas.

TESTING AND TRIAL DEPLOYMENT OF A COST-EFFECTIVE AND REAL-TIME ASPHALT PAVEMENT QUALITY INDICATOR SYSTEM

NCHRP-IDEA Project 32

Harry Apkarian [Tel: (518) 370-5558, Fax: (518) 370-5538], Raymond J. Piascik, and Frank S. Ralbovsky, TransTech Systems, Inc., Latham, New York

The project designed and tested a low-cost pavement quality indicator based on capacitance energy dissipation to measure density of asphalt pavements as a rapid, convenient, and safe alternative to nuclear gauge. A prototype system was designed (Figure 1) and tested on calibrated hot-mix asphalt cores of various thicknesses as well as on a variable-density stack of thin glass plates separated by measured air gaps to verify the system's accuracy, repeatability, temperature stability, sensitivity, and time stability. Also, the effects of various probe configurations and carrier frequencies were investigated. The prototype was subjected to preliminary field tests, and modifications of the system were made that included fine-tuning of the electrical circuit. Three prototype units were fabricated for field evaluation. The field test results were carried out at six sites in Nevada, New York, and Indiana. The field results showed that the instrument measures to a 2.5-in. depth at a speed of about 5 seconds per reading with good accuracy and reproducibility. The field performance was unaffected by temperature and moisture variations. The probe and the sensor circuit were redesigned to improve their accuracy. A market research study was conducted to determine the competition and demand for the IDEA product. The final report is available from the National Technical Information Service (NTIS #PB97-201503).



Figure 1

Advanced prototype of TransTech System's pavement quality indicator.

HIGHWAY GUARDRAIL INFRASTRUCTURE: SAFER TERMINAL DESIGNS

NCHRP-IDEA Project 34

James F. Wilson [Tel: (919) 660-5194, Fax: (919) 660-5219], Duke University, Durham, North Carolina

This project developed a unique class of guardrail terminal retrofits suitable for secondary roads (Figure 1). The main feature of these new terminal structures is that they do not penetrate errant vehicles but bend upon impact and form sufficient frontal area to mitigate vehicle spearing. Made of mild steel, these terminals curve away from the direction of traffic flow, have variable depth corrugations, have an increasing flare toward the impact end, and have breakaway supporting posts.

A static, elastic-plastic failure analysis for the new-concept terminals was performed. After formulating the governing equations and identifying the important design parameters, several curved and flared terminals were designed that would interface the common W-type guardrails. An experimental program was carried out on half-scale models for two types of designs. In accordance with predictions, the static buckling experiments showed that plastic buckling did occur at the third point from the clamped end (end that interfaces with the W guardrail section).

Low-speed crash tests were performed on half-scale terminal models in which Duke University's test car, traveling at about 5 mph and without bumper shock absorbers, impacted the models head-on. These test results showed that the plastic failure zones occurred further toward the tip of impact than for static loading, or at about the two-thirds point from the fixed end.

The ideal final design of a guardrail will incorporate the following features.

- A retrofit that is low cost, simply fabricated, and easily installed.
- A retrofit that buckles plastically near mid-length.

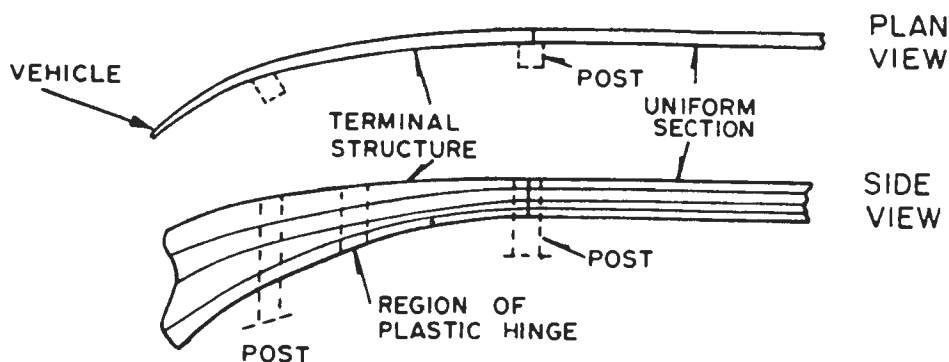

Figure 1

A terminal structure concept designed to avoid vehicle spearing.

- A retrofit that helps redirect impacting vehicles and minimizes fatalities for their occupants.
- A retrofit that limits the ridedown deceleration of the impacting vehicle to 15 g.

The principal investigator, with Duke University's Office of Science and Technology, is processing a patent on this product and plans to work with a potential product developer who would be granted a license to manufacture and then transfer this product to practice. The final report is available from the National Technical Information Service (NTIS #PB 98-139058).

SECTION 2 ACTIVE IDEA PROJECTS

This section reports progress on all NCHRP-IDEA projects that were completed or active during the 1999 program year.

LASER REMOVAL OF PAINT ON PAVEMENT

NCHRP-IDEA Project 16

Hans Pew and James Thorne, MOXTEK, Incorporated

IDEA Product

A prototype portable laser for removal of paint from paved highways, parking lots, and airfield runways will be developed. Its impact will be (a) the elimination of the usual environmental contaminants such as grit, dust, smoke, and chemicals; (b) prevention of damage to pavement during paint removal; and (c) completion of removal for compliance with federal codes that require no visible trace of temporary markings on newly constructed roadways.

Concept and Innovation

Lasers typically remove paint by heating, charring, and slow burning with air or an oxygen jet. Another approach is the use of a succession of short, intense, laser pulses that create destructive shock waves rather than heating to the point where chemical reactions occur and smoke is generated. Several brands of lasers were tried in the laboratory to demonstrate such removal.

IDEA Project Investigation and Progress

Laboratory results showed that removal was clean, but not fast. The best criterion for rating laser performance is the volume of paint it removes per second. This depends primarily on five factors: 1) the energy per pulse, 2) the duration of each pulse, 3) the number of pulses per second, 4) the depth of paint removed per pulse, and 5) the area of paint irradiated by each pulse.

The maximum energy per pulse and the number of pulses per second should be maximized, and this suggests the use of a very large laser. However, beyond about 25 watts of average power in the light beam, initial costs become prohibitive. In addition, the bulk and maintenance of large lasers hinder their use in this application. There is every reason to believe that diode-pumped lasers will be smaller and more powerful in the near future, but a careful search found none currently available in the range of power needed. Lasers driven by flash lamps will continue to be used until diode-pumped lasers meet the criteria of cost and effectiveness.

The investigators previously reported on a number of experiments that provided information on the depth of paint removed by each pulse as a function of the area of irradiation for two lasers: the Coherent Infinity laser and the Instamark Elite laser system. These will now be compared to recent experiments with the CFR-800 laser at the Blue Sky Laser Technology applications laboratory. While there, we irradiated marking materials including lacquer (Bauer UN1263) and cold polymer. Measurements to some marking materials not previously studied by the investigators, namely hot polymer and epoxy, were also included. The results are shown in Table 1.

TABLE 1. Results of laboratory laser tests on ablation of various markings.

Paint	Substrate	Laser	Shots	Diam, cm	Ablation, cm³/kJ	Notes
LacquerU N1263	Concrete	CFR 800	2	0.7	362	Becomes resistant
LacquerU N1263	Concrete	CFR 800	10	0.7	86	Somewhat erratic
LacquerU N1263	Concrete	Coherent Infinity	52	0.71	104	Thick paint
LacquerU N1263	Asphalt	CFR 800	5	0.95	140	Paint bonded poorly
LacquerU N1231	Asphalt	Lumonics CO2	10	0.5	Very low	Almost no ablation
Epoxy	Concrete	CFR 800	10	1.35	492	High MW/cm ² threshold
Cold Polymer	Sheet	CFR 800	5	1.2	195	Softens at high rep rates
Hot Polymer	Sheet	CFR 800	2	1.25	190	Softens at high rep rates

The maximum depth of removal per pulse was between 20 and 95 μ m in each of the materials. Surprisingly, the epoxy paint was removed with better efficiency than the others. This was attributed to the rigidity and brittleness of the epoxy, which promotes efficient shock propagation and cracking. The other polymeric materials are typically not densely crosslinked, and they contain small voids as do most linear, glassy polymers. The investigators suggest that this structure weakens the shock wave, and that it converts a larger fraction of the shock energy to heat than the epoxy does.

Plans for Implementation of IDEA Results and Product

The funding for this contract was insufficient to purchase a laser for installation on the mobile unit; however, Spectra Physics Corp. has agreed to attach one of their larger lasers to the mobile carriage in their laboratory. It will be operated there to ablate paint while being videotaped. The tape and experimental results will be used to convince one or more distributors to buy a laser for a demonstration unit that can be shown to prospective customers. Plans for the manufacture and sale of production units for paint ablation are being arranged.

COST-EFFECTIVE MICROWAVE SENSOR TO DETECT HIGHWAY ROAD CONDITIONS

NCHRP-IDEA Project 31

Robert Kubichek [Tel: (307) 776-3182, Fax: (307) 766-4444],
Electrical Engineering Department, and Suzanne Yoakum-Stover,
Physics and Astronomy Department, University of Wyoming, Laramie

This IDEA project started in May 1996 and was completed in April 1998.

A new method for measuring moisture, snow, and ice accumulation on roads and highways using microwave-sensing techniques was developed. The microwave sensor is sensitive to small changes in road condition and relatively immune to effects of blowing snow, antenna icing, changes in humidity, and other environmental effects. It provides the capability of real-time detection of deteriorating road conditions due to rapidly evolving weather systems and eliminates inherent delays associated with eyewitness reporting methods.

The system works by switching a low-power microwave signal between two high-gain antennas pointed toward reflectors on the far side of the road. The upper reflector (R) directs the signal back toward the road surface, where it reflects up to the receiver antenna (Figure 1). The lower reflector (D) directs signal energy directly back across the road without reflection from the road. The magnitude and phase of the reflected signal contain information about the amount and type of precipitation on the road surface. The direct signal takes almost the same path through space but has not undergone a road reflection. Thus, it provides a reference for subtracting out time-varying effects unrelated to road surface conditions. The complete system comprises two separate transceiver systems operating at frequencies of 2 and 10 GHz. Dual frequency operation offers additional independent information about the amount and type of precipitation on the road for improved reliability.

Tests conducted over two winter seasons identified early problems with using the direct signal as a reference to subtract out environmental effects. Alternative antenna and reflector geometry have alleviated the problems. System hardware and analysis software were refined during the testing as well. Benefits of the sensor system include real-time information for more area than is possible with embedded sensors, relatively low cost, no human operator is required, and redeployment to any remote location to provide better, faster, and cheaper road reports.

Cooperation was received from the Wyoming Department of Transportation (WY-DOT) during the 1996-1997 winter season, and this cooperation is expected to continue. Several companies have expressed interest in the technology. These include In-Situ, a Laramie, Wyoming, company specializing in remote sensing equipment; Nu-Metrics, a company that is building a system for the Pennsylvania DOT to monitor state highways, especially ice and water conditions on the roadway; and Atmospheric Environmental Services in Toronto, Canada. No actual technology transfer is expected until the system design becomes finalized. The project has received high visibility through newspaper articles and TV and radio segments and was even the subject of a short article in *Popular Science* magazine.

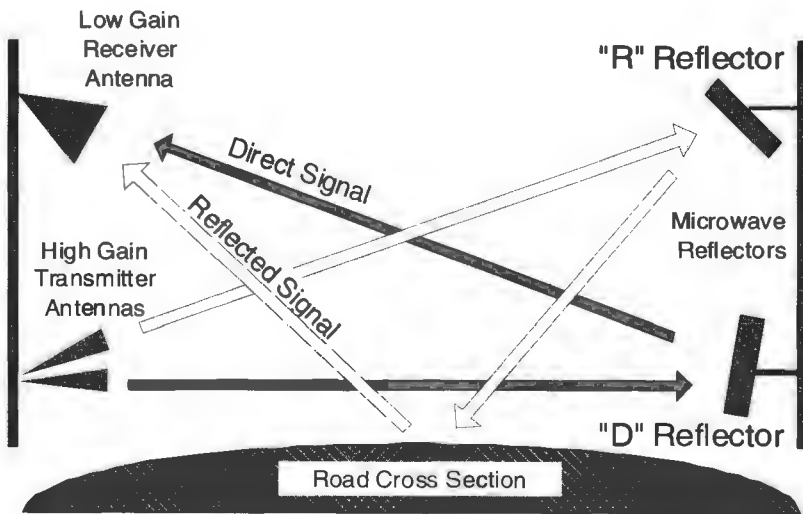

Figure 1

Antenna and reflector geometry, showing reflected and direct paths. Shown is the 10-GHz system; an identical 2-GHz system is implemented using dish antennas.



Figure 2

2-GHz (left) and 10-GHz (right) antennas.

EVALUATION OF A NEW REHABILITATION TECHNOLOGY FOR BRIDGE PIERS WITH COMPOSITE MATERIALS

NCHRP-IDEA Project 33

Roberto Lopez-Anido, Rakesh Gupta,
Hota V.S. GangaRao [Tel: (304) 293-7608, Fax: (304) 293-7609],
Udaya B. Halabe, Sachin Kshirsagar, and Reynold Franklin,
West Virginia University, Morgantown

This IDEA project started in November 1996 and was completed in October 1998.

This IDEA project examines the process and possible causes of damage due to harsh environmental conditions of concrete pier columns wrapped externally with glass fiber composites. Major emphasis is on evaluating long-term performance and durability of such a wrap system. The investigators have evaluated the durability of fiber composite wrap systems and the bond between the composite material and concrete in order to establish the protection levels and confinement of concrete under harsh environments, freeze-thaw effects, and moisture seepage.

The system evaluated is a fiber composite wrap applied by wet lay-up. In this system, the fiber sheet (fabric) is presaturated in a specially formulated epoxy resin and then is wrapped around a concrete column, much like applying wall paper. The system is applied in the following situations: seismic retrofit, repair, defects in design, defects in workmanship, and environmental protection. The system is used to repair concrete bridge pier columns, pier caps, pier walls,



Application of fiber composite wrap on Pond Creek Bridge.



Pier concrete column after wrapping.

Figure 1

Field installation of the composite wrap rehabilitation technology.

beams, and piles. The proponent of the Fibrwrap™ system is Hexcel Fyfe Co., L.L.C., San Diego, California.

The fiber material is a hybrid of E-glass and polyaramid called SEH-51 (Knytex). The fibers are supplied as a woven fabric sheet. The fiber reinforcement is mainly placed around the column in the hoop direction. The resin material is a two-part epoxy called Tyfo S. The installation process is simple and fast and does not require expensive equipment. The advantages of this process are as follows: resin cure at ambient temperature, flexibility of the wrap system, and ease of use in restricted areas. The main issues of concern in this repair system are quality control of the resin mix, wet-out of the fabric, uniformity of the resin distribution, compaction and fiber wrinkling, and control of resin cure. The fiber composite wrap system has the following cost benefits: (a) reduction in installation time as compared to conventional repair methods, (b) increase in shear/flexural strength and ductility of piers and columns, and (c) long service life and reduction in maintenance cost.

A bridge in need of column repair was selected by West Virginia Department of Transportation, Division of Highways (WVDOT-DOH), to demonstrate the IDEA product. The subject bridge is the Pond Creek Road Overpass Bridge carrying Interstate Route 77 in Wood County, West Virginia. According to the WVDOT-DOH Condition Report (dated September 1, 1994), six columns of two piers have vertical hairline cracking. These cracks resulted from a previous unsuccessful repair with a concrete layer after the columns were subjected to fire and the original concrete cover was lost. Three columns of Pier 2 of the bridge (northbound) were repaired in July 1998 with the fiber composite wrap system evaluated through the IDEA project (Figure 1). The other three columns were repaired using prefabricated composite cylindrical shells. The investigators have monitored the field performance of the repaired columns, and the initial results are satisfactory.

IN-SERVICE REPAIR OF HIGHWAY BRIDGES AND PAVEMENTS BY INTERNAL TIME RELEASE OF REPAIR CHEMICALS

NCHRP-IDEA Project 37

Carolyn Dry [Tel: (217) 333-1913, Fax: (217) 244-2204],

Illinois Universities Transportation Research Consortium, Chicago

This IDEA project started in December 1996 and was completed in December 1998.

The project develops and tests a self-repairing concrete system based on internal time-release of chemicals encapsulated in hollow fibers and embedded in concrete, in large-scale laboratory tests and in field conditions on bridges.

Twenty-one small frame specimens (10' x 10' x 1") were fabricated containing hollow fibers at the joints and were tested with various adhesives for deflection and stiffness. The results showed that during the second test of the frames, after the adhesive had been released, cracks at joints, which had been repaired with stiff adhesives, did not reopen, causing the stresses to be translated to other joints and to the mid-spans of members. Frame concrete specimens were fabricated containing hollow fibers designed to allow release of stiff adhesives at joints and to assess the action of flexible adhesives at member midsection locations. These frames were tested twice under static loads, and the performance showed stress transfer behavior from the adhesive-stiffened joints to the flexible mid-span locations, where some damping occurred. A third test under cyclic static loads was done. Deflection was measured. The results show that the frames containing the adhesives had less permanent deflection.

By using a full-scale demonstration and placing the adhesive-filled fibers in the commercial concrete mixer from which various samples are poured, the investigator evaluated the following issues:

- Will the fibers withstand traditional finishing methods? Yes.
- Will the changes in temperature cause the release process to cease? No.
- Will the adhesives stay fluid in the fibers? Yes.

The potential payoff of the product includes the following benefits:

1. Bridge frames subjected to dynamic loading would be less subject to destruction if the stresses were spread about the structure and if the joints and midspans could become preferentially stiffer, allowing better control of damping and deflection. Appropriate internal release of adhesives into the frames makes this possible.

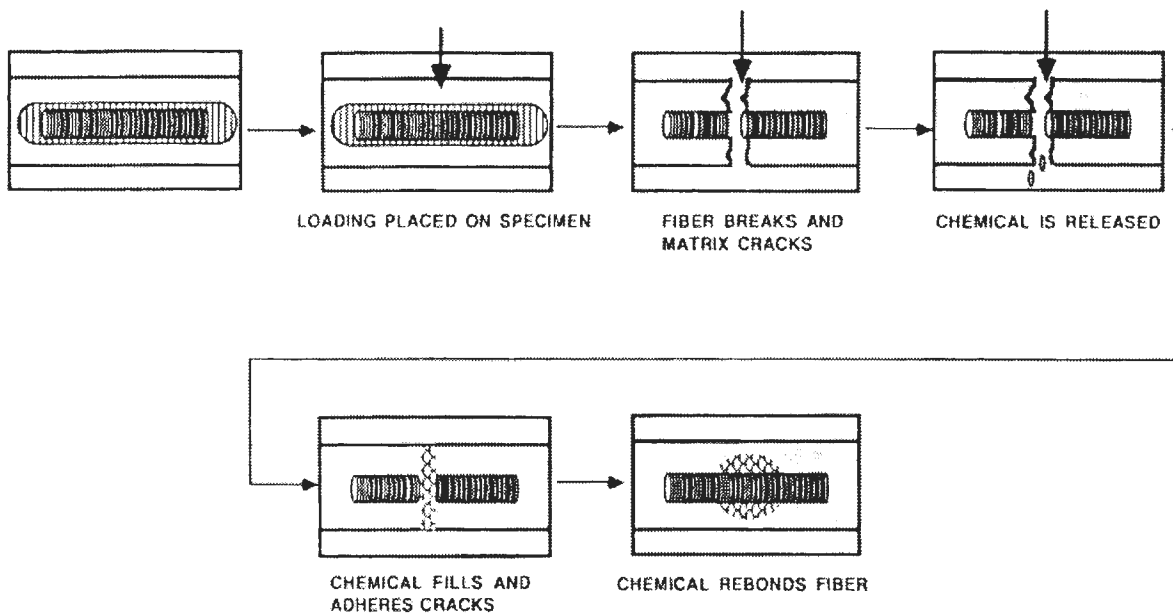

Figure 1

Concept of in situ self-repair of concrete by adhesives in embedded hollow fibers.

2. Transverse cracks in bridge decks grow and allow water to ingress through the deck onto rebars and the superstructure below, causing structural degradation. Adhesive-filled fibers have the potential to seal areas of expected cracking (i.e., over the transverse rebars). This will potentially provide a control joint, so that cracks are organized, and a sealant for this joint, so that water does not penetrate to the rebars or structure below.
3. The observation of cracking behavior and presence in opaque matrices is difficult. The development of optical fibers and ETDR cables used in hollow glass tubes could be of use to “see” inside the opaque matrix.

The investigators performed field evaluations in cooperation with the Illinois Department of Transportation, and with Wiss Janey and Elstnor on transverse cracking of bridge decks. Several commercial cement companies and four other state DOTs have expressed interest in working on field evaluations. Currently there is a proposal to the Illinois Department of Transportation to test the technology as a drying shrinkage remedy in a bridge deck in use in the field.

PAINT REMOVAL FROM STEEL STRUCTURES: TESTING AND DEMONSTRATION OF ELECTROSTRIP™ PROCESS

NCHRP-IDEA Project 38

Rudolf Keller [Tel: (724) 335-2666, Fax: (724) 335-8402] and Brian J. Barca,
EMEC Consultants, Export and New Kensington, Pennsylvania

This IDEA project started in November 1996 and was completed in June 1998. The IDEA project advisor was Dr. Gerardo Clemeña, Virginia Transportation Research Council.

The ElectroStrip™ Process to remove paint from metal surfaces has been awarded U.S. Patent and an additional patent application, on an improved pad design, is pending.

The process involves the application of cathodic current to induce debonding of paint coatings, making use of ElectroPads™ containing the electrolyte and a counterelectrode. Such pads are attached to the structure by means of magnets, and dc current is applied for a duration of ½ to 2 hours. To permit this current to flow, the paint surface, unless sufficiently deteriorated, must be scored. The voltage applied to the pads ranges from 6 to 10 V, which is an occupationally safe voltage. A rectifier with an 8,000-A capacity can accommodate pads covering an area of 160 ft² at a time. Pads are removed with the debonded paint after the treatment and processed to separate paint components or discarded for recycling after one use.

The proposed mechanism of debonding is indicated in Figure 1. The cathodic current produces hydrogen and OH⁻ ions. This induces a strongly alkaline condition, very localized at the metal surface. Due to a chemical action, bonds between metal and coating are attacked in a saponification reaction.



Figure 1

Treated area after initial cleaning.

The ElectroStrip™ technology offers an environmentally friendly way, with minimal occupational hazards, to remove lead-based paint from steel structures.

The ElectroStrip™ approach to paint removal has several significant advantages:

- Easy containment of hazardous waste: no toxic paint fragments (lead dust) become airborne;
- Only benign chemicals are used;
- Stripped paint can be recovered and recycled in a lead smelter; no lead-containing waste needs to be landfilled;
- The process is cost-effective at any scale and requires relatively small investments; and
- Interference with traffic flow and noise pollution are minimal.

Cost projections indicate a competitive price of \$7 to \$10 per ft² for full paint removal and repainting. This is similar to quoted average costs for traditional abrasive blasting. Investments in equipment are relatively modest; for example, a crew handling an area of 80 to 100 ft² an hour will require about \$40,000 as an initial investment (not including the power generator).

Before full commercial implementation of the technology, additional optimization efforts must be conducted and scale-up equipment acquired. Some additional process demonstrations will have to be conducted on a non- or near-competitive basis.

Systematic characterization of depainted surfaces and studies of repaintability have been initiated. Early results indicate good adherence of coatings. It was observed that the ElectroStrip™ treatment converts rust to magnetite, which then can be readily cleaned off. Preliminary studies of effects on mill scale are also encouraging. There is promise for a broad application of the technology.

ESTIMATING TRUCK ATTRIBUTES FROM BRIDGE STRAIN DATA USING NEURAL NETWORKS

NCHRP-IDEA Project 40

Dr. Ian Flood [Tel: (352) 392-7287, Fax: (352) 392-9606, E-mail: flood@ufl.edu],
ME Rinker Sr. School of Building Construction, University of Florida

IDEA Concept and Product:

The project was concerned with the development of a neural network-based method of accurately estimating truck attributes (such as axle loads) from strain response readings taken from the bridge over which the truck is traveling. The approach is designed to remove the need for intrusive devices (such as tape switches) on the deck of the bridge to obtain such data so as to provide a convenient and viable means of collecting bridge loading statistics. The system has many practical applications, which can be broadly classified under two headings: (1) to enforce legal weight limits on trucks without the need to stop those vehicles for weighing; and (2) to obtain comprehensive statistics for use in, for example, highway bridge design or fatigue rating of existing bridges.

The main problem with the existing system is that the tape switches rapidly deteriorate in heavy traffic, particularly following precipitation. The presence of the tape switches also warns truck drivers that the bridge is instrumented. As a result, they may moderate their speed or avoid the bridge, thus introducing bias into the collected data. The solution considered here was to develop a neural network-based method of estimating truck attributes (such as axle loads, velocity, and axle spacings) solely from the transducer strain readings. This has the advantage of removing the need for the tape switches, or other bridge deck instrumentation. In addition, the approach makes use of the existing WIM strain transducer technology, and is thus inexpensive to develop and implement.

Project Results

A two-stage neural network system was considered, as illustrated in Figure 1. The first of the two stages (that shown to the left of the figure) is designed to classify a given truck loading condition and thus select an appropriate set of networks from the second level of the system. The laterally connected architecture shown at level 1 in the figure is typical of networks used for classification purposes (in this study a binary classifier was considered - EHAM), though conventional feedforward networks were also experimented with for this first level network (in this case RGIN). The networks in the second level were designed to operate for a given truck loading class, providing estimates of velocity, axle spacings and axle loads. Backpropagation (GDR) and RGIN networks were considered here.

A total of 4,131 training patterns were set-up for a range of truck axle spacings, and axle loads (representing variations on each truck type in the FHWA system of classification), and for a range of truck velocities.

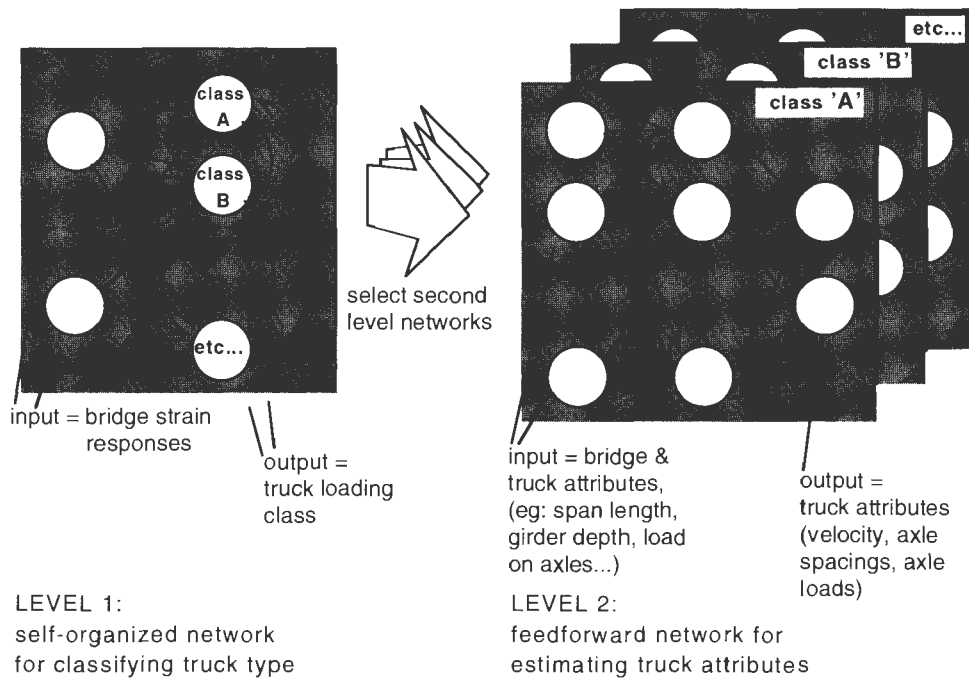

Figure 1

Architecture of Proposed Networking System

The first series of experiments were concerned with the development of the truck classifier (see Level 1 in Figure 1). The EHAM networking system required a maximum of 917 hidden neurons to learn all the training patterns at an output, while the RGIN network was found to improve little beyond 1,000 hidden neurons for any output. The performance of the networks, once trained, was measured using example truck crossing events not used for training. In each experiment, the percentage of correct and incorrect classifications by the network were registered. Table I shows the performance of both the EHAM and RGIN networks for the 9,000 test patterns (1,000 patterns per truck type in the FHWA system of classification). It is clear from these results that there is little to distinguish between the two types of network in terms of performance. However, the EHAM network has the advantage of being simpler in form and two to three orders of magnitude faster to train.

An important observation made in this series of experiments was that the truck misclassifications tended to be between trucks with the same number of axle clusters. This suggests that an improvement could be achieved by classifying trucks in two tiers of neural network, the first of which would identify the number of axle clusters on a truck, and the second to refine this classification to a specific FHWA category. The ability of such an approach to decrease the percentage of misclassifications is currently under investigation.

TABLE I. Performance of Neural Networks for Truck Classification Problem.

FHWA Truck Class	% Correct Classifications	
	Binary Network (EHAM)	Radial-Gaussian Network (RGIN)
2S	92.3%	93.1%
3S	89.6%	90.2%
4S	88.2%	84.3%
2S-1	91.0%	89.4%
2S-2	88.0%	87.8%
3S-1	86.1%	85.3%
3S-2	88.2%	81.3%
3S-3	89.7%	86.4%
2S-1-2	76.1%	79.2%

At the second level in the system (see the right hand side of Figure 1) are a set of neural networks designed to estimate truck attributes. For each class of truck, there is a separate neural network to determine axle spacings, axle loads, and velocity.

The performance of the second level networks can be no better than the performance of the first level classifier network. That is to say, if the first level network were to misclassify a truck, then the wrong networks would be selected from the second level in the system, and thus the truck attribute estimations will be invalid. The second level network has been shown in earlier work to provide an acceptable degree of accuracy assuming that the first level network correctly classified the truck. The emphasis of this study was, therefore, on ensuring correct first level classification, and to see if an alternative networking system could improve on the performance of the second level in the system.

Of the two types of networking system evaluated for the second level in the system, the RGIN approach was found to significantly outperform the GDR. A major problem with GDR was that it was very slow to train, often taking several days, and often did not converge on a solution at all. Where GDR did converge, its performance at truck attribute estimation was considerably below that of RGIN. For RGIN, typical results provided estimates that, for 90% of the test cases, had absolute errors within 6.4kN for axle loads, 0.78m for axle spacings and 6.2km/h for truck velocity. These results are encouraging, though ways of further improving performance, especially removing outlying results, are being considered.

Product Transfer

Implementation of the system is being pursued through several routes, including state departments of transportation (in particular the Florida Department of Transportation), and industry (through collaboration with a California-Finland based company).

FIELD TESTING WITH THE DUOMORPH: A SELF-CONTAINED PORTABLE DEVICE FOR SHRP BINDER TESTING

NCHRP-IDEA Project 41

Samuel H. Carpenter [Phone (217) 333-4188 Fax: (217) 333-1924], University of Illinois

Idea Concept and Product

The Strategic Highway Research Program (SHRP) developed new testing protocols for the testing and grading of asphalt cements. The resulting specification represents the first time that fundamental testing of a rheological nature is used as an integral part of the specification and purchase process for asphalt binders. The equipment for this classification is expensive and limited to testing in a laboratory environment on materials with little particulate concentrations. The Duomorph is a piezoelectric sensor that can be embedded in a viscoelastic material and determine the modulus and phase angle of the material, the same data required for the Superpave binder grading. This device has potential to allow Superpave grading information to be obtained on asphalt materials at the plant. It can be used on materials as they are being blended to verify the properties without sampling and transporting back to the laboratory. This project evaluated the durability of the Duomorph and the capability to determine Superpave properties comparable to laboratory testing. The final product would be a device and supporting electronic equipment that would allow rapid determination of Superpave binder properties on a real-time basis as the materials were delivered or produced.

Project Results

The first phase of this project evaluated the durability of the Duomorph and assembled the necessary electronic equipment to operate the Duomorph and record the data. This equipment was assembled into the Duomorph Asphalt Rheology Tester (DART). The DART was found to be durable and possible of providing accurate determinations of the stiffness (G^*) over the range of temperatures of interest to binder grading (70°C to -24°C). Difficulties were encountered in determining the phase angle at higher temperatures in the range above 35°C. In the range of 35°C to 0°C the phase angle was comparable to that determined from the standard Dynamic Shear Rheometer (DSR). Testing was conducted on original binder, RTFOT aged binder, and PAV aged binder for these comparisons. Parametric studies of the Duomorph physical properties (diameter, thickness, piezo material type) were conducted to verify the suitability of gauge sizes required for testing liquid asphalt binders.

Phase 2 work was directed toward simplifying the data reduction process to provide an automated scheme, and at improving the analysis procedure to eliminate the phase angle measurement inaccuracy at elevated temperatures. Continued testing showed the accuracy of the DART to be as good and as repeatable as the DSR. Viscoelastic 3-D finite element modeling was performed that reproduced the laboratory measurements and was used to produce a solution set for a wide variety of material properties.

Work is continuing on refining the analytical scheme to provide for an automated data collection and data reduction capability. Without this capability, the scheme is too cumbersome to be used by a technician in the field as it requires use of separate computer programs and nomographs to extract the information. Discussions are under way with an equipment manu-

facturer to consolidate the electronic equipment into a small portable unit suitable for field use. The development of an analysis procedure is expected to be completed by December 1999.

Product Payoff Potential

The Duomorph assembly, termed DART, has the potential to provide a portable field device that can be used at a plant or refinery to verify the more extensive laboratory testing program used for material certification. DART can be used on modified asphalts with particulate matter such as crumb rubber-modified binders. It can be used at the plant to test asphalt that has been blended with a polymer to verify the blending process. It can be used on material sampled directly from a tanker to verify that the material is the same as what was specified. This ability to provide a rapid indication of product acceptability before use could result in significant savings by avoiding using materials that later are proven to be unacceptable. This use as a fingerprinting tool for monitoring material variability using the same material properties that are determined in the full grading acceptance scheme provides a unified process in a real-time format not previously possible.

Product Transfer

Discussions are underway on an informal manner with an equipment manufacturer to determine if the commercial potential is suitable for development of the electronic package. These discussions will continue.

DUAL-CORE FIBER OPTIC WIM SYSTEM

NCHRP-IDEA Project 42

Ramesh B. Malla [Tel. (860) 486-3683, Fax (860) 486-2298, E-Mail: mallar@engr.uconn.edu],
Associate Professor, Department of Civil and Environmental Engineering,
University of Connecticut

Norman W. Garrick, Associate Professor,
Department of Civil and Environmental Engineering, University of Connecticut

This IDEA project started in June 1997 and was completed August 1999. The IDEA project advisor was Dr. Robert Gubala, Connecticut Department of Transportation (retired).

IDEA Concept and Product

The product from this project will be a sensor for weighing and counting highway vehicles. This weigh-in-motion (WIM) system will be used on roads that are functioning under normal conditions and will cause no disruption to traffic. The technological breakthrough behind this WIM sensor is a unique dual-core optical fiber that is radically different from most fibers currently used in civil engineering and other sensing applications. It is anticipated that this WIM will be simpler to install and operate and will be more accurate than comparable devices.

The anticipated enhanced capabilities of this system result from the inherent advantages of the dual-core fiber compared to the conventional sensor fiber technology. The dual-core fiber has two concentric light-guiding regions of different effective optical path length; this design enables users to measure magnitude as well as the position of forces applied at multiple locations along a single fiber and using a single light source and photodetector. It is anticipated that this device will be configured to give not only vehicle weight and volume but also speed, inter-axle distance, and lateral vehicle location.

Product Payoff Potential

Highway deterioration accelerates exponentially as truck weight increases. Accurate data on vehicle weights are essential for the design and management of highway pavements. Currently, we do not have comprehensive data on the weight distribution of vehicles using our highways. Reliable, inexpensive and easy-to-use WIM would help to correct this problem resulting in improved highway design procedures. Each year over \$7 billion is spent on highway construction, rehabilitation, and maintenance, improved WIM technology will help to save a significant fraction of this direct cost. The cost of traffic data collection processes is also expected to decrease with the development of this product.

Project Results

A prototype WIM system was designed and fabricated. The system was tested both with loading machines and with an actual vehicle. As a part of this process, the optical fibers used in the system were characterized and calibrated.

In the vehicle test, the prototype was installed between wooden tracks that were used to simulate a pavement. The vehicle (a passenger car) was then driven over the system and the

optical signal was recorded for various locations of the car wheel over the prototype WIM device (Figures 1 and 2). An automated computer system was developed to acquire and analyze the data from the prototype WIM sensor device. The laboratory test results of the prototype WIM proved to be very promising. The load test showed a very good relationship between the magnitude of the applied load and the changes in the optical signal. Furthermore, the changes in the optical signal during testing with the car were quite similar to those obtained for the load machines. Figure 1 shows the car wheel testing in progress. Figure 2 shows the time delay of the output light pulses traveling through the fiber before and after the vehicle wheel load. This time delay pinpoints the location of load application to a fair degree of accuracy. The intensity change in the signal before and after the load gives a good measure of the magnitude of the wheel load. Based on these results, the prototype shows potential for accurately determining the magnitude and location of vehicular loads.

The test results have given us the information needed to improve the configuration of the system and in general to optimize our prototype in terms of size and performance. A second-generation prototype will be designed and built and additional tests will be conducted to fully characterize its performance. In addition, a dedicated optical system that will be rugged enough for field-testing is being developed.

PRODUCT TRANSFER

The Connecticut DOT has been involved with the project from its conception and will provide help and advice for the field-testing. It is anticipated that they will serve as beta testers for the prototype. The advisory panel consists of members with connection to user agencies (including FHWA) and industry. The advice of this panel continues to be valuable in product development and technology transfer.



Figure 1

Car Wheel testing in Progress

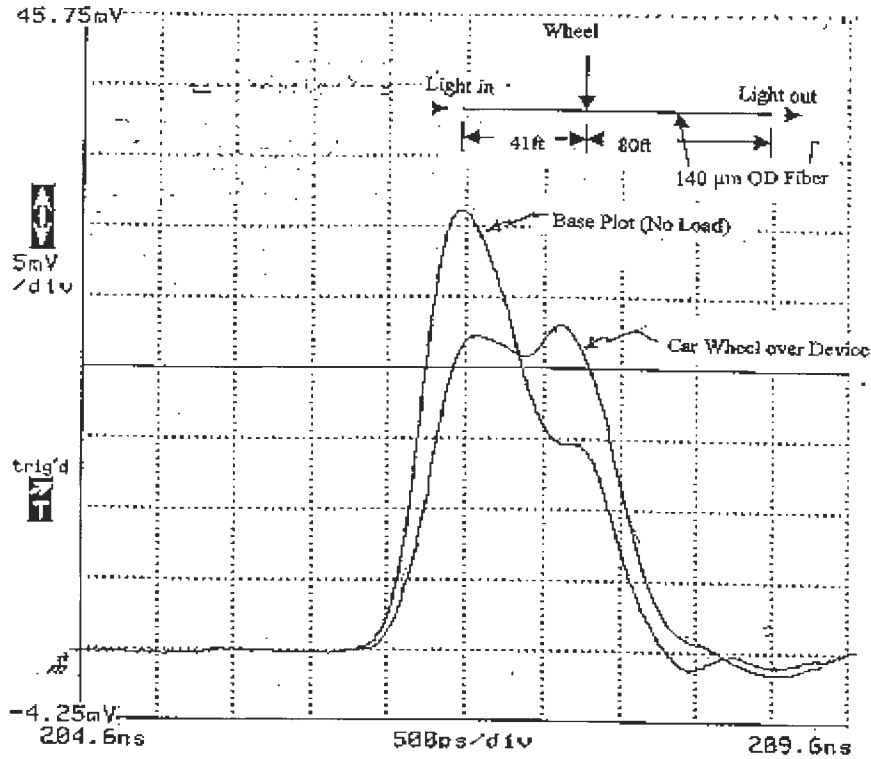

Figure 2

Oscilloscope Traces from Car Test

An industrial affiliate, MetriLight, Inc., is supporting this work by providing the optical fiber. MetriLight principals were the inventors of the fiber and hold the patent to this product. They have also provided invaluable consulting help.

To date, three MS-level students have received training under this project. Results from the project have been presented at five conferences or workshops (including the NSF/FHWA International Workshop on Fiber Optic Sensors for Construction, Materials and Bridges in May 1998) and have appeared in one quality publication.

ROBOTIC SYSTEM FOR UNDERWATER BRIDGE INSPECTION AND SCOUR EVALUATION

NCHRP-IDEA Project 43

James DeVault [Tel: (913) 532-4594, Fax: (913) 532-1188],
Kansas State University, Manhattan, Kansas

This IDEA project started in June 1997 and was completed in December 1998.

The project investigated the feasibility of using a semiautonomous robotic system to position a sensor platform in close proximity to underwater bridge support structures while providing video or other sensory information to support evaluation and documentation of structural condition, including scour.

The primary system consists of two or more identical mobile robots designed to travel along opposite surfaces of submerged structures while connected to one another by a cable and winch system. Each robot contacts the surface through cleated rubber tracks (or, alternatively, wheels and rubber tires) that are driven by internal motors. Tensioning the cables that connect the two robots provides traction. In response to an operator's command to move to a new position, the robot team automatically coordinates both movement and cable tension. A graphical user interface provides the operator status information and control options. This robotic system may be used to augment traditional diver inspections, thereby reducing diver time and cost and enhancing safety.

This system incorporates hydraulic motors on an open-frame structure. The weight of the system is minimized and the control electronics are separately housed and located above water. An in-river demonstration of the prototype system under manual control is planned.

Two prototype systems have been constructed and tested, and the findings applied to development of a third system of significantly different design. This system has a broad array of potential applications for inspection of submerged physical structures, such as bridge substructures,



pipelines, water towers, industrial smokestacks, nuclear cooling towers, oil rigs, oil derricks, floating platform support structures, and docks.

Initial estimates of the manufactured costs of the system range from \$25,000 to \$50,000. The proposed system could pay off in as few as 30 hours of operation.

The Kansas State University Research Foundation is pursuing patent protection for all aspects of this system. The Mid-America Commercialization Corporation (MACC) markets the technological property of the university and negotiates license agreements for the transfer and successful commercialization of the inventions. MACC reviewed this technology and found significant commercialization potential. MACC is undertaking a major role in the effort to place this technology in the marketplace and is developing an appropriate commercialization strategy and plan. Two local companies (ICE Corporation and Devore Systems, Inc.) have expressed early interest in the manufacture of the electronic components of the system.

ROLLER-MOUNTABLE ASPHALT PAVEMENT QUALITY INDICATOR USING DIFFERENTIAL MICROWAVE SIGNALS

NCHRP-IDEA Project 44

Edward J. Jaselskis [Tel: (515) 294-5225, Fax: (515) 294-8000], Iowa State University, Ames

This IDEA project started in August 1997 and was completed in December 1998.

This project investigated a new approach to measuring, for the first time, the density of asphalt in real time using differential microwave signals. This novel approach is based on the continuous comparison of two microwave signals reflected by the pavement, one in front of the breakdown roller and one behind it.

Horn antennas are used to transmit and receive the microwave signals, which are processed using an on-board computer. The variability of the reflected microwave signals is compared from the front to the back of the breakdown roller. An abrupt change in the variability of the reflected signal from the front to the rear of the roller indicates that the mat has reached proper compaction. Roller operators receive real-time information regarding the density of the hot-mix asphalt pavement. Operators are also able to determine how effective their equipment and techniques are in terms of efficiency in achieving optimal density.

Previous field test results have demonstrated a useful trend that may be applied to predict the density of pavement during the compaction process. It was found that the variance in the returning microwave signal decreases as density increases. A sharp increase in variance has been identified at approximately 93% of Rice density. Further compaction shows a similar decreasing trend in the variance. These results were obtained in two independent field tests.

The IDEA project is a continuation of research resulting from the findings of two field tests and is divided into three phases: (a) laboratory testing to better understand the electrical dynamic effects of microwaves on asphalt pavement, (b) prototype design and fabrication, and (c) field testing. Currently, the laboratory testing and prototype development phases have been completed and the team is in the process of field-testing the prototype (see Figure 1).



This novel real-time measurement approach uses low-power microwaves to assess asphalt pavement density. This is potentially safer to operate compared to the nuclear density gauge, which requires technicians to be certified on an annual basis and have the equipment inspected periodically as well. This new approach is relatively inexpensive and requires less maintenance effort compared to the nuclear density gauge. Using a differential approach creates the added benefit of not having to calibrate the instrument to cores of known density. This microwave sensor might also change the paving pattern, which currently includes systematic passes on the inside, outside, and middle portion of the mat. With this new sensor, the operator simply paves in a straight line (up and down) until the proper level of compaction is attained before moving over to the next strip in the mat. Each strip may require a different number of passes to meet density due to the decrease in asphalt pavement temperature with time.

The Iowa State University Research Foundation has initiated the patent application process for this idea based on the promising results shown to date. Additionally, the Center for Advanced Technology and Development at Iowa State University is in the process of identifying companies interested in licensing this technology. Some companies have already shown interest in this invention; their future involvement depends on the success of the field-testing phase.

PERFORMANCE EVALUATION OF BASALT FIBERS AND COMPOSITE REBARS AS CONCRETE REINFORCEMENT

NCHRP-IDEA Project 45

Vladimir Brik [Tel: (608) 244-1349, Fax: (608) 244-9071],
Research and Technology, Inc., Madison, Wisconsin

V. Ramakrishnan, South Dakota School of Mines and Technology, Rapid City

This IDEA project started in November 1997 and was completed in October 1998.

This research explores the suitability of basalt fibers and basalt fiber composite rebars in highway concrete reinforcement applications. Basalt fiber composite rebars and cables containing about 80% fibers and bonded with epoxy resin show tensile strength almost three times that of reinforcing steel rebar in addition to their excellent corrosion resistance.

Basalt fiber composite rebars have the potential to replace steel as concrete reinforcement where corrosion of reinforcing steel is a problem, such as in salt water environments. Rebars made of basalt fiber composite weigh only one-third as much as steel rebars and have a coefficient of thermal expansion close to that of concrete, making them potentially more compatible for concrete reinforcement than steel.

Test results on basalt fiber-reinforced concrete can be summarized as follows:

- Satisfactory workability of concrete can be maintained with the addition of up to 0.5% (by volume) of basalt fibers. Much larger quantities of fibers can be added without causing any balling or segregation.
- The performance of basalt fiber-reinforced concrete appears to be similar to that of polypropylene fiber-reinforced concrete currently being used in the market.
- Addition of basalt fibers increases the toughness and impact strengths of concrete as compared to plain concrete.

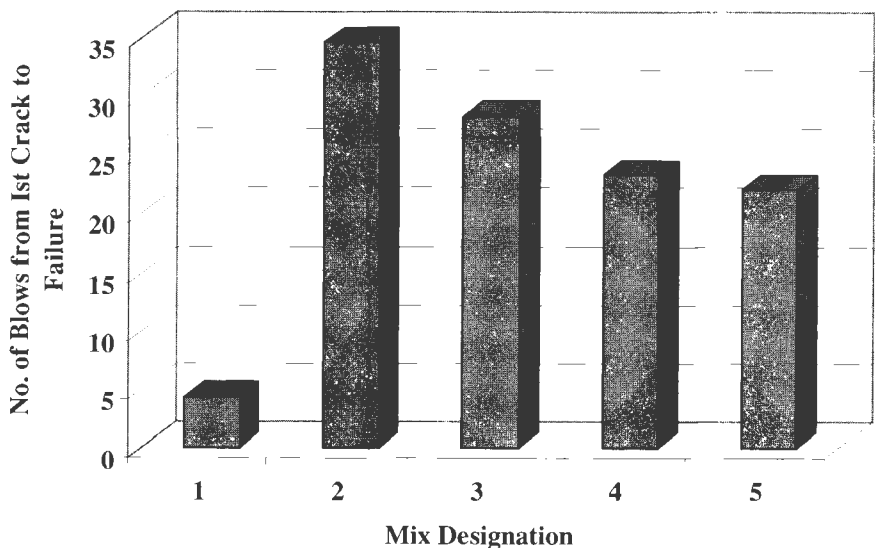

- An important contribution of basalt fiber addition is the change of failure mode from brittle to ductile failure when the concrete is subjected to compression, bending, and impact.
- The performance of concrete could be further improved by increasing the length of basalt fibers to 25 to 50 mm.

Basalt fiber composite rebars in prestressed concrete tests showed adverse performance as compared to steel rebars because of the creep at the rebar and cement matrix interface. Additional research is needed to improve the bonding at the interface to overcome this problem.

The principal investigator is exploring other avenues for implementation and commercialization of the IDEA product. Discussions are under way with the Wisconsin Department of Commerce for support from its Technology Development Fund to explore the use of locally available basalt mineral from northern Wisconsin and Minnesota for manufacturing basalt fibers and basalt fiber composite materials.

FIBER-REINFORCED POLYMER HONEYCOMB SHORT-SPAN BRIDGE FOR RAPID INSTALLATION

NCHRP-IDEA Project 46

Jerry D. Plunkett, Stephen R. Gill, Kansas Structural Composites
[Tel: (785)483-2589; Fax (785)483-5321; e-mail: ksci@ksci.com], Russell, Kansas

David A. Meggers, Kansas Department of Transportation, Topeka

This project was started in October 1998 and is scheduled for completion in November of 1999.

IDEA Concept and Product

The concept of this project has been to develop an adaptable fiber-reinforced polymer (FRP) decking system for replacement of existing superstructures on vehicular bridges that no longer meet current highway load and lane width standards. Bridges in this category may be found throughout the United States, the estimated number being 150,000.

The basic problem in the rehabilitation of these structures is one of cost and time; construction of a completely new bridge creates great inconvenience to the general public and requires many hours of design time. Many bridges deemed deficient are still structurally sound, but have deteriorating superstructures that require replacement. The existing roadway may also have accumulated numerous layers of overlay during its lifetime. This can create excessive dead load on the structure, necessitate the re-rating of the bridge to lower weight limits and force large vehicles to detour around the area—a particular problem in rural areas. In addition, current highway standards may require greater lane width. The policy in Kansas is to bring any bridge under rehabilitation up to current weight and lane standards. In the case of the two bridges involved in this project, this required the removal of approximately 10 in. of asphalt overlay to remove excessive dead load, and the widening of the road surface from 26 ft to 32 ft.

Of further concern is the method of matching the existing road grade without the removal of large quantities of material on the approaches, the application of large quantities of material



Figure 1

Deck panels.

on the new deck, or being forced to produce an over-designed (and therefore materially inefficient) deck. The removal of roadbed is time consuming and inefficient and may be impractical where the grade is particularly long and flat. Application of additional material, building up the deck to meet the approaches, defeats the purpose of lowering dead load. The inefficiency of over-designing the deck is obvious, and is particularly so when using relatively expensive materials such as FRP. In order to make this product cost-competitive, optimization in the use of materials is of prime importance.

An additional problem is attachment of a prefabricated deck to the existing structure. It was a goal of this project to design a device that would require little skill and equipment to install, while providing a solid anchorage for the deck.



Figure 2

Saddles.

In order to meet all the diverse criteria, this project has developed a versatile system of light-weight deck panels supported on prefabricated FRP saddles that will lower dead load and match existing grades, with an attachment device that requires a minimum of equipment and expertise to install.

The panels are of FRP honeycomb sandwich construction, approximately 5 in. thick with a 3/8-in. polymer concrete wear surface. Total weight for the deck for each of the 45 ft x 32 ft bridges is approximately 25 kip, replacing an estimated 88 kip of existing roadbed; a 70% reduction in dead load. They were fabricated as flat, half-width panels, then joined at the centerline, on a bias, to produce the lateral gradient necessary for rainwater runoff.

The saddles are also of FRP honeycomb construction, designed to straddle the existing beam flanges. The flat panel/saddle design was used to reduce the total amount of material while allowing the deck surface to be matched to the current grade.

The attachment device is a clamp designed to be installed from the deck surface, eliminating the need to work on or under the bridge structure along with the consequent expense and safety hazards. The result is a steel L-bracket that clamps the deck to the flange of the existing structural steel. It is bolted through the joints between panels, allowing the deck joints to be sealed. The bracket and the saddles are in the process of being patented.

This product is an extension of the concepts devised during fabrication and installation of a short-span FRP bridge in Russell County, Kansas under a previous IDEA program grant. That project showed the viability of the type of construction described above. It is believed, however, that the most cost-effective application of the technology to bridges would be rehabilita-

tion of existing structures by combining the FRP sandwich panel concept with more conventional methods of construction such as steel and concrete.

Product Payoff Potential

As previously stated, the number of functionally deficient bridges in the United States is enormous. In the opinion of many informed observers, the nation's highway infrastructure has been woefully neglected for many years. This has created a backlog of needed construction and rehabilitation that has only recently been begun. Continued growth in transportation makes it imperative that the maintenance and replacement of the existing infrastructure be economically efficient so as not to impinge on funds needed for future expansion. The development of cost-effective products such as the subject of this report will be necessary if the problem is not to become chronic.

The design and testing phase of this project provided KSCI with much useful data that may be applied to further applications of this product. Publicity from this and other projects has resulted in inquiries from numerous engineering and architectural firms world wide, as well as various state transportation agencies regarding applications ranging from bridge replacement to building repair. The structural and construction parameters of this project as described above are not limited solely to transportation infrastructure: the concept of light-weight, cost-effective structural panels can be extended well beyond the current project to many areas of civil and structural engineering.

Project Results to Date

The investigation of the design for the bridge decks was completed in the winter past. The proposed design and materials have been tested for strength. Results of the testing show a factor of safety against ultimate failure of better than 10.

Fabrication of the deck panels and saddles was completed in the summer of 1999, and the attachment devices are currently in fabrication.

It was originally expected that this project would have been completed in spring 1999; however, inclement weather in southeast Kansas and very heavy construction schedules have delayed the field work for the project considerably. As of the date of writing (September 1999), the field construction contracts had been let and initial earthwork at the sites is scheduled to begin the 27th of September. Installation of the deck system is scheduled for early November 1999.

PAVEMENT QUALITY INDICATOR: FIELD OPERATIONAL TESTING AND PRODUCT TRANSFER

NCHRP-IDEA Project 47

Harry Apkarian [Tel: (518) 370-5558, Fax: (518) 370-5538] and Peter Sawchuk,
TransTech Systems, Latham, New York

This project started in December 1997 and was completed in August 1998.

The density of hot-mix asphalt is generally considered the most important construction variable in the long-term durability of paved surfaces. The product idea being developed by TransTech Systems, Inc., in this IDEA project is an advanced pavement quality indicator (PQI) that can be used to make real-time, in situ measurements of pavement density. The device is intended to provide density measurements based on nonintrusive, nondestructive, nonradioactive detection techniques suitable for static and in-motion measurements.

The PQI is lightweight and very easy to use. No licensing processes are required. Virtually any member of the paving crew or department of transportation can easily operate the PQI with little training. Pavement readings are instantaneous, and data can be electronically transferred to a computer for processing. The accuracy and repeatability of the PQI's density measurements are excellent compared to existing alternatives.

This project represents the third phase of development of an advanced pavement quality indicator, building on successes in IDEA Project NCHRP-32. In past phases, the PQI was demonstrated to be a viable approach for making real-time measurements of asphalt pavement density in a nondestructive, nonnuclear format. This project demonstrated the PQI in field operational tests at various locations with various asphalt mixes and obtained valuable data to guide the final commercial design.

In addition, post-project accomplishments included gathering continued field test data, achieving initial market exposure through press releases in major trade journals, and obtaining approximately 100 unit orders. Figure 1 shows a production model PQI.

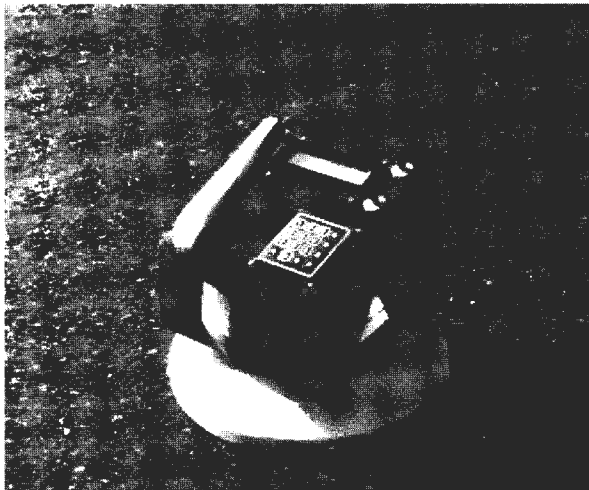

The PQI's ability to instantaneously read asphalt pavement density creates a cost-effective opportunity to dramatically increase the number of density readings taken on the highway and provide real-time feedback to the paving crew for instantaneous corrective action. It appears that this measurement technique could replace the current core sample and laboratory analysis used to determine asphalt densities today. Development and deployment of the PQI in the asphalt paving industry will yield more efficient paving opera-

tions, higher productivity, and better quality control, and thus result in longer-life pavements with lower overall life-cycle costs.

Additional benefits include the potential improvements in energy and environmental impacts. Conservative estimates by TransTech of just the energy and environmental impacts associated with the paving process show the potential of saving 2.35×10^{13} BTU per year and 90 tons of air emissions per year. These estimates are based on reasonable penetration rates for the technology and do not include the added positive energy and environmental impacts from reduced traffic congestion due to less frequent road repair requirements.

Additional applications for the technology exist in the areas of soil density measurement, subgrade quality control in pavement construction, and compaction measurements in a wide variety of civil construction applications.

FIELD TRIAL OF SHAPE MEMORY-BASED REHABILITATION SYSTEM

NCHRP-IDEA Project 48

Ken Ostowari [Tel: 517-349-5653; Fax: 517-349-5653], DPD, Inc., Lansing, Michigan
Parviz Soroushian, Prof., Civil&Env. Engrg., Michigan State University

IDEA Concept and Product

Shape-memory alloys based on Fe are used to apply corrective forces to concrete structures. Fe-based alloys provide, at relatively low cost, the opportunity to transfer corrective forces for rehabilitation and strengthening purposes through electrical resistance heating of the reinforcement system with, say, a welding generator.

Product Payoff Potential

The technology promises to enhance the efficiency and expedience of structural repair projects and to save cost and substantially reduce the need for heavy equipment on rehabilitation project sites. New developments in Fe-based shape-memory alloys favor cost-effectiveness. The technology could also be applied to new construction.

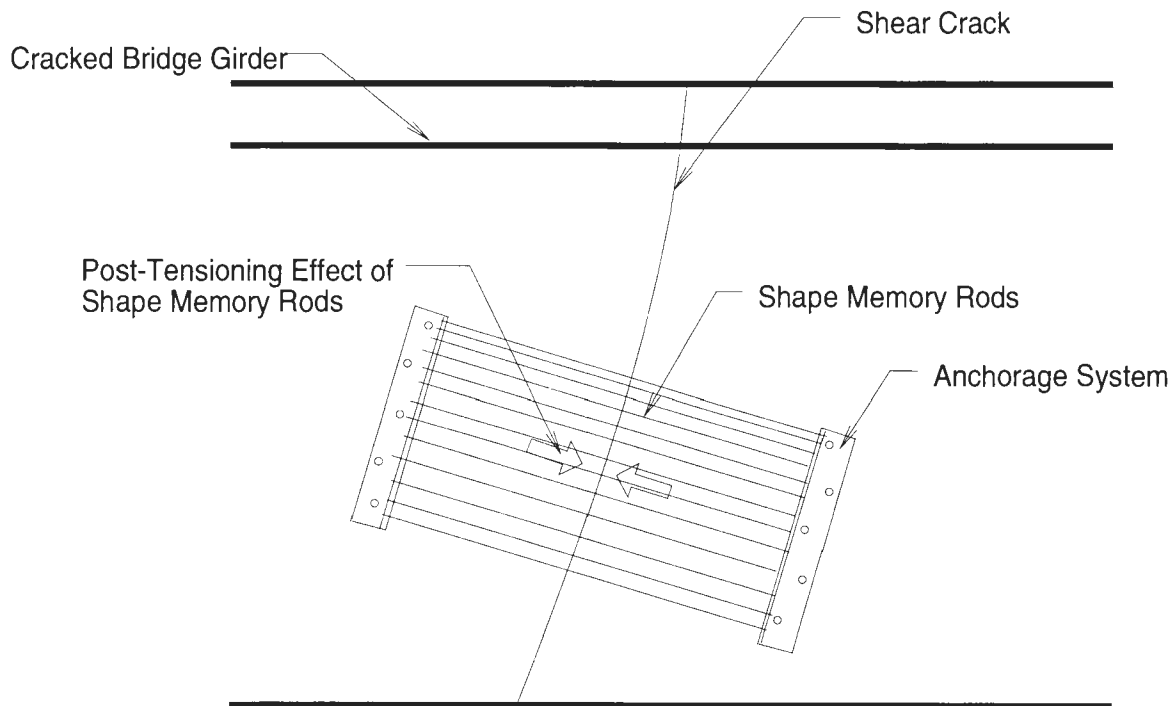

Figure 1

Schematic Presentation of the Field Demonstration Project.

Project Results

The feasibility of rehabilitating damaged concrete structures with the relatively low-cost Fe-based shape-memory alloys has been demonstrated in a laboratory using relatively large-scale reinforced concrete specimens. A field project, involving rehabilitation of a reinforced concrete bridge that has suffered shear cracking, has been selected in cooperation with the Michigan Department of Transportation. Exhaustive structural analyses and designs have been undertaken together with MDOT engineers in order to adapt the technology for application to this bridge system. This application, schematically depicted in Figure 1, involves anchorage of shape-memory rods to the concrete web in order to transfer corrective post-tensioning forces to the cracked area of the reinforced concrete beam. Planning efforts are in progress for implementing the field project in October 1999.

Product Transfer

DPD, Inc. has filed a patent application on the technology, and is working closely with the Michigan Department of Transportation towards field demonstration of the technology.

AUTOMATION OF LEGENDS PAINTING

NCHRP-IDEA Project 49

Duc Huynh [Tel: (510)438-9714, Fax: (510) 438-0194],
Pavement Marking Technologies, Inc.

This project started in March 1998 and scheduled to be completed in December 1999.

IDEA Concept and Product

This project develops and tests a mobile automatic legend painter. The system allows an operator to paint any legend from inside the cab of the truck faster than any other method currently available. The system is based on a unique patented control algorithm. In current form, the system is implemented with a multiaxis gantry system as shown in Figure 1. The system is specifically designed to take advantage of the next generation of marking material (track free in less than 3 minutes and 100% solid). The goal is to produce a fully automated system that can apply a legend and be open to service in 7 minutes or less.

Project Results

A second generation prototype was built to demonstrate various features of the system:

- Safety
- Cycle time
- Application quality
- Software reliability
- Hardware reliability

Several demonstrations of various stages of the project were made to a panel of local advisors comprising private contractors, city, county, and state agencies, and consultants. The latest demonstration was to a major European contracting company. The feedback is very positive.

Currently, the system is being modified to incorporate a laser alignment system to aid the operator in the task of aligning the truck so that the new legend will cover the worn out legend. Also, due to major delay and change in direction of U.S. developers of the next generation marking material, system development is delayed awaiting an approved material.

Nevertheless, in its current state, the RoadWriter™ demonstrates that it can deliver the next generation of equipment to apply legends that offers tremendous improvement in safety, speed, quality, cost, versatility, and waste. Specifically, the system provides the following benefits:

- Apply patterns without requiring the crew members to step into traffic, thereby increasing safety and efficiency.
- Apply a typical "STOP" legend in less than 5 minutes, including approach and departure time. This is a major improvement to current method.
- Apply an even thickness of material, resulting in optimal material usage and avoiding premature wear.



- Allow a legend truck to apply virtually unlimited patterns, restricted only by the computer storage capacity; this is in contrast to existing equipment, which is severely limited by the physical storage space available on the truck.
- Apply patterns without the required maintenance of traditional stencils.
- Change the current two-person operation to a one-person operation.

Upon the finalization of the 100% solid material the system is designed for, the system will demonstrate the following benefits:

- Apply reflective glass beads immediately into the material stream as it hits the road surface, thereby achieving maximum bonding strength and penetration.
- Apply a fast-drying material (track free in less than 3 minutes), thereby reducing cycle time and traffic interruption and eliminating coning requirement.

Product Payoff Potential

As a fully automated system, the system has the potential to dramatically improve the safety, quality, versatility, and economy of the legend-painting task. It is estimated that the RoadWriter™ could increase the productivity of a crew by eight times. Also, it is estimated that the new-generation marking material, which is less temperature sensitive, can be applied both earlier and later in the construction season, resulting in dramatically improved utilization of equipment and labor.

Product Transfer

The system has been demonstrated to contractors, city, county, and state agencies and consultants. The results indicate strong demand for the technology. Two major equipment manufacturers express strong desire to license the technology for markets in the United States, Europe, and Asia. Negotiations are under way to help expedite the project through the last development phase and to commercialize the invention.



DAMPER SYSTEMS FOR SUPPRESSION OF BRIDGE STAY CABLE VIBRATIONS

NCHRP-IDEA Project 50

Habib Tabatabai and Armin B. Mehrabi [Phone (847)965-7500, Fax (847)965-8997],
Construction Technology Laboratories, Inc., Skokie, IL 60077

Final report has been submitted.

IDEA Concept and Product

Incidences of large-amplitude vibrations of stay cables (on the order of 1 to 2 meters) have been reported worldwide when certain combinations of light rain and moderate winds (10 to 15 m/s) exist. This aerodynamic phenomenon, known as “rain-wind induced vibration” is a widespread problem. It can result in long-term cable wire fatigue problems at anchorages. The researcher’s database of cable-stayed bridges around the world indicates that intrinsic damping ratios of most cables are not sufficient to protect against the phenomenon. Historically, various cable vibration control measures have been utilized for a small proportion of the cable-stayed bridge infrastructure domestically and internationally. These include neoprene washers (rings), cross cables (or cross ties), external viscous dampers, and modified polyethylene sheathing. The most effective among these measures are viscous dampers. However, these possess significant limitations regarding maximum attainable damping, maintenance requirements, and bridge aesthetic issues.

The original “intrinsic” concepts proposed and explored in this study involved the potential adaptation of damping traits of various cable fillers that would suppress cable vibrations. Other concepts for increasing cable damping, such as the use of neoprene rings and polyurethane rings near the ends, and damping tapes, were also evaluated during the course of this study. Two innovative stay cable damper concepts, adapting tuned mass and tuned liquid concepts (namely “Tuned Mass Damper” (TMD) and “Tuned Liquid Damper” (TLD)), were identified, developed, and tested for the first time on stay cable scaled models. These damper concepts address the primary deficiency of conventional viscous dampers for cables since they can be attached at any point along the length of cable and produce significant vibration sup-

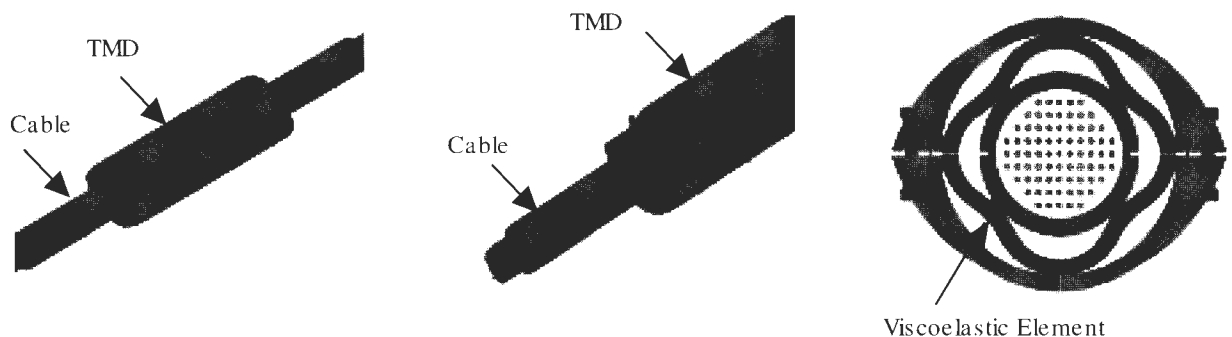

Figure 1

Schematic of a tuned mass damper

pression. The TMD concept was the most effective method tested in this investigation and possesses the highest potential for a relatively low-cost damper. Figure 1 shows a schematic of a proposed TMD system for stay cables. The proposed device consists of a viscoelastic element (spring/dashpot) contained between an outer cylinder (mass) made of steel or similar material and an inner cylinder (the cable). The viscoelastic element can be formed in various shapes to achieve the desired spring constants. The ends of the outer cylinder can be sealed using neoprene boots, and the mass of the cylinder can be tuned to match the frequency of the cable.

Project Results

The effectiveness of a large array of damping treatments and methods was comparatively assessed using 1/7th scale stay cable models. The extent and variety of testing necessary to adequately compare various damping treatments would not have been possible or practical if prototype cable testing were contemplated. Measurement of damping was performed using the free vibration decay method. In this method, an accelerometer was attached to the cable at mid-length. The cable was deflected at mid-span using a weight hung from the cable by a string. The string was then suddenly cut with a sharp knife to excite the first mode vibration of the cable. The subsequent cable vibrations were recorded using a high-speed data acquisition system. To obtain a "reference cable" response, the damping associated with the model cable filled with conventional cement grout and without a damper of any type was measured. As expected, the measured damping in this case was very low (0.05%). Testing of the model cable filled with a latex modified cement grout (with a higher loss factor) indicated a damping ratio of 0.08%.

When neoprene rings were installed inside guide pipes at both ends of the reference cable, the measured damping ratio reached as high as 0.61% (or over 10 times higher than the same cable without neoprene rings). It should be noted, however, that the performance of the neoprene rings is highly dependent on the tightness of fit inside the guide pipe and the level of pre-compression (or confinement) in the neoprene material. The polyurethane material placed between the guide pipe and the cable did not improve cable damping substantially when compared to the conventional neoprene rings. In the case of damping tapes covering the middle 20% of the reference cable, the damping ratio of the cable was 0.05% or unchanged from the reference cable. An additional layer of tape covering the middle 40% of cable length increased cable damping to 0.08%. None of the methods described had a significant increasing effect on the cable damping.

To model a tuned liquid damper, a PVC container was attached to the cable at 20% and 42.5% of the cable length from one end (in separate tests) and was filled with various volumes of water, oil, or lead shot. In no case did the damping level increase beyond 0.20%. However, it should be noted that the theoretical design of a TLD system for cables involves extensive investigations beyond the scope of this project. It is anticipated that an effective and proper combination of damper design incorporating internal paths or tubes to regulate and tune the process of movement of liquid can be found.

The tuned mass damper system was modeled by positioning known masses at various locations along the cable (distances of 10, 20, 30, 40, and 50 percent of the cable length from one end) using springs with spring factors ranging from 0.44 to 5.3 kN/m. In general, the tuned mass dampers were able to improve the cable damping within a wide range of mass proportions and spring factors. However, at each location there was a combination of mass and

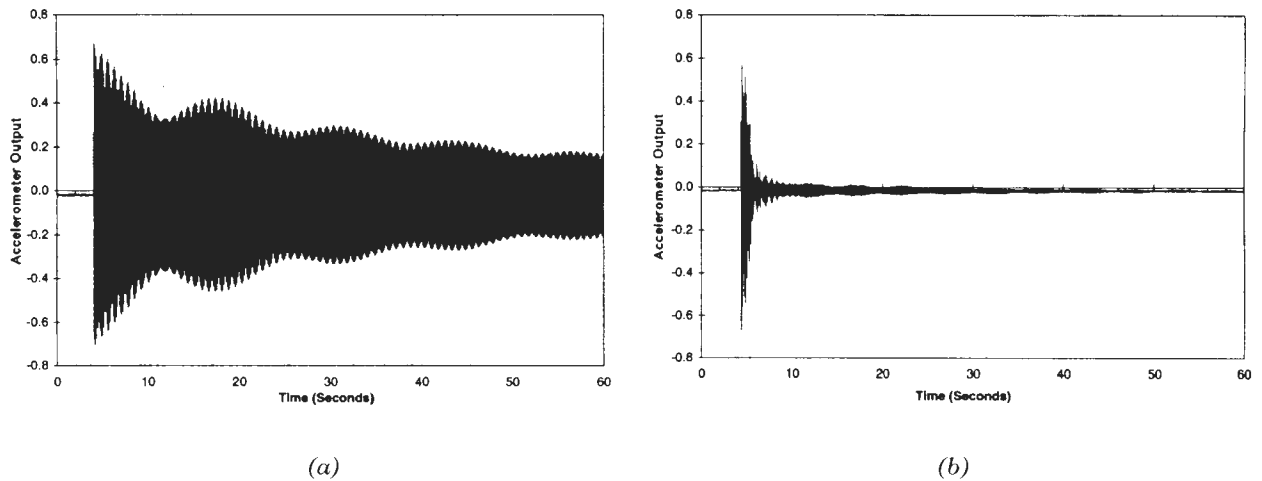

Figure 2

Comparison of cable responses, (a) without TMD; (b) with TMD

spring factor that resulted in an “optimum” tuned mass damper. Figure 2 shows the time-domain responses of the reference cable with and without a mass-spring system attached. Comparison between responses of the cable with and without a damper attached shows significant improvement achieved by TMD. The spring located at 20% of cable length from one end was a tension spring with spring factor of 0.44 kN/m with a hanging mass of 1020 grams (approximately 3% of the total cable mass). The damping ratio achieved was 2.35%.

Product Payoff Potential

The TMD concept proved very successful in raising the effective damping ratio of a cable beyond the threshold of vulnerability to rain-wind and galloping vibrations. It is expected to be a low-cost, low-maintenance vibration control option that can be applied to both existing and new stay cables. Compared to conventional viscous dampers or other alternatives, TMD offers higher efficiency, lower cost, no positioning limitations, smaller size, low maintenance, and better aesthetics. It is believed that the tuned mass damper concept can be developed successfully into a marketable product. To achieve that goal, a number of steps must be taken. These include detailed design and fabrication of a prototype TMD, testing and evaluation of the TMD in the field, and securing collaborative agreements with potential users of the product.

Product Transfer

It is proposed that a prototype TMD system is developed, installed, and evaluated on one or more stay cables of a bridge exhibiting rain-wind vibration susceptibility. The research team has been involved in an evaluation of stay cable vibrations on the Cochrane Bridge in Mobile, Alabama. This bridge will be retrofitted with a large number of mechanical viscous dampers for stay cables in 2000. This bridge or the Charles River Bridge in Boston (under construction) could potentially be used to test TMD. It is proposed that cable vibration measurements be taken for a period of at least 2-3 months before and after installation of damper. Such monitoring is currently planned for the conventional damper installations on the Cochrane Bridge. It is also proposed that additional analytical work be performed to prepare design charts for

selection of damper size and locations. Durability testing of the prototype damper would also be another area deserving consideration.

At this point, at least one stay cable manufacturer has expressed strong interest in commercial development of these dampers. It is expected that, if and when contacted, other such users would also express interest. Cable suppliers can furnish these dampers as an integral part of their cable systems or provide them as retrofit measures on existing cables.

APPLICATION OF ADVANCED COMPOSITES TO STEEL-BRIDGE RETROFITTING

NCHRP-IDEA Project 51

Dennis Mertz, John Gillespie, Jr. and Michael Chajes, University of Delaware

IDEA Concept and Product

Our nation's highway bridges are in dire need of rehabilitation or replacement. Innovation is required to deal with this problem, as funds do not exist to repair or replace our bridges in a conventional manner. Many of the oldest in-service bridges are steel bridges. Better technologies for rehabilitation are needed, and the application of advanced composites may be the best available alternative. Bonding advanced composite materials to deteriorated steel components may prove a better, more durable, and cost-effective solution for the rehabilitation or strengthening of steel highway bridges than traditional methods. These modern materials can improve the service life of existing steel bridges with reduced maintenance.

Product Pay-Off Potential

Conventionally, steel highway-bridge components are rehabilitated or strengthened by field-bolting or field-welding a steel plate to the component. The process of field-welding steel plates to steel components introduces such severe fatigue-inducing flaws at the ends of the plates in the base-metal of the component that most jurisdictions prohibit the practice. (In fact, the fatigue provisions of the AASHTO Standard Specifications for Highway Bridges specify fatigue resistances for shop-welded details only). Many jurisdictions also have concerns with the unknown weldability of older steel bridge components and the associated risk of fracture from welding.

The process of field-bolting retrofit steel plates to steel components is very labor intensive, and thus extremely expensive. The entire process can result in significant lane- or bridge-closure times.

Bonding composite plates to the flanges or webs of rolled beams or built-up riveted or welded steel plate girders is less labor intensive than field-bolting steel plates. The bonding process proposed herein will reduce the time between repair and the resumption of service. Further, this process does not introduce fatigue-initiation sites into the base-metal of the component. Finally, the composite plates are non-corrodible.

Planned Investigation

An NCHRP Highway-IDEA concept exploration project (NCHRP-93-ID-011), at the University of Delaware, in conjunction with the ATLSS Center at Lehigh University, proved that composite carbon-fiber plates bonded to steel components, both new and weathered, significantly increase the stiffness and static strength of the steel components. While this retrofit concept holds great promise, it is not yet ready for application in general practice. As the original proposal for the concept exploration project indicated, fatigue behavior and environmental durability must be addressed prior to application to general practice if the static behavior proves adequate, as it has.

A product application IDEA project is investigating the application to practice of this newly proven concept of bonding composite carbon-fiber plates to steel components to increase their stiffness and static strength. The topics under investigation are the fatigue resistance and environmental durability of the retrofit.

The main objective of this application project is to demonstrate the acceptability of this concept for deployment into mainstream bridge retrofit practice through laboratory and field experimentation. A secondary objective is to apply existing advanced composite materials technology from the military industries to the civil infrastructure. With the end of the Cold War and our nation's decreasing military budget, the composites industry is in danger of dying. Not only would this affect our nation's military preparedness, but also our economy. The increased and appropriate use of advanced composite materials in the civil infrastructure can save the industry and our bridges. Also, large cost savings in bridge retrofit practice may be realized.

The work plan includes two concurrent parts:

- 1) laboratory investigation of the fatigue resistance of the retrofitted steel highway-bridge components, and
- 2) field testing of the retrofit on an in-service steel highway bridge owned by the Delaware Department of Transportation.

The field testing will provide validation of the laboratory fatigue studies to be conducted concurrently, and the accelerated environmental durability tests performed previously as a part of the U.S. Department of Defense projects at the University of Delaware.

A project panel, consisting of practicing bridge engineers and academics, has been assembled to provide guidance to the researchers. The laboratory-based fatigue study is ongoing and nearing completion. A candidate in-service bridge has been selected by the project panel for retrofitting and the University and DelDOT are mobilizing to complete the retrofit.

Product Transfer

The proposed NCHRP Highway-IDEA project is being administered through the Delaware Transportation Institute (DTI), a joint venture of the University of Delaware and DelDOT. The University's relationship with DelDOT through the DTI allows enhanced technical exchanges among researchers, practitioners, and others, ensuring that the concept will be amenable to deployment into bridge practice in terms of design, construction, and maintenance. This relationship fosters technical understanding at DelDOT along with increased understanding of practical issues at the University. The DTI is guided by a Policy Council that includes membership from DelDOT and other state agencies that oversee economic, industrial, and environmental issues for the State of Delaware. This structure facilitates interaction between transportation, industrial, and other groups that may be involved with, or may benefit from, the project.

In addition to providing an in-service steel highway bridge as a testbed, DelDOT is providing technical assistance and guidance. Similarly, the Federal Highway Administration is involved through their Division office in Dover, Delaware, their regional office in Baltimore, and their central office in Washington, DC.

ENVIRONMENTALLY FRIENDLY PASSIVATING COATINGS FOR STEEL REBARS

NCHRP-IDEA Project 52

Dr. James E. Neely, Jr. [Tel: (724)-482-2163, Fax: (724)-482-2767], Neely Industries, Inc.

Professor Alberto Sagues [Tel: (813)-974-5819, Fax: (813)-974-2957],
University of South Florida

Mr. Rodney Powers [Tel: (352)-337-3134, Fax: (352)-334-1649],
Florida Department of Transportation

Professor Richard Brown [Tel: (401)-874-2707, Fax: (401)-874-4689],
University of Rhode Island

IDEA Concept and Product

The concept of this proposal is to apply a new environmentally friendly, passivating coating onto rebar to inhibit corrosion. These coatings are a new class of environmentally friendly, water-based, inorganic copolymers that contain no heavy metals, heavy metal compounds, or organic solvents. These new passivating coatings have excellent corrosion inhibition performance over a wide range of pH, especially at the high pH that is typical of concrete. These coatings have been shown to passivate the surface of low carbon steel as shown by electrochemical measurements and other corrosion tests conducted at the University of Rhode Island by Professor Richard Brown. Specifically, potentiodynamic scans, AC impedance, and salt spray tests have been conducted under a variety of conditions, including simulated marine environments. During these tests passivation layers formed on the bare metal surface at defects deliberately made in coated low-carbon steel. As a result, resistance to corrosion remained high, and no undercutting occurred. Results of a comparison study between damaged epoxy-coated rebar and damaged inorganic polymer-coated rebar is shown in Figure 1. Although passivation-type coatings are well-known, currently available coatings contain toxic materials, such as chromates, that do not provide adequate protection at high pH. The new environmentally friendly coatings also contain no VOCs.

Project Results

AC impedance spectroscopy and salt fog tests were conducted at the University of Rhode Island by Professor Richard Brown on inorganic copolymer (ICP) coatings applied by Neely Industries, Inc. on low-carbon steel panels and reinforcing steel (rebar). These tests were conducted to select the best performing inorganic copolymer coating formulation for use in conducting ASTM G-109 concrete slab tests of coated rebar at the University of South Florida and the Florida Department of Transportation.

Inorganic copolymer-coated panels were clamped onto the bottom of test cells containing a solution of saturated calcium hydroxide in 0.25 N sodium chloride. AC impedance was measured periodically as exposure time to the solution increased. The impedance values compared were those at a frequency of 0.1 Hz, which represents a near DC condition. Coating 189 had the highest impedance at the beginning but not after 49 days. Coating 206 showed the highest impedance after 49 days, but it was unstable during the initial period of exposure. Although the initial impedance value for coating 206 was less than 40,000 and it varied consid-

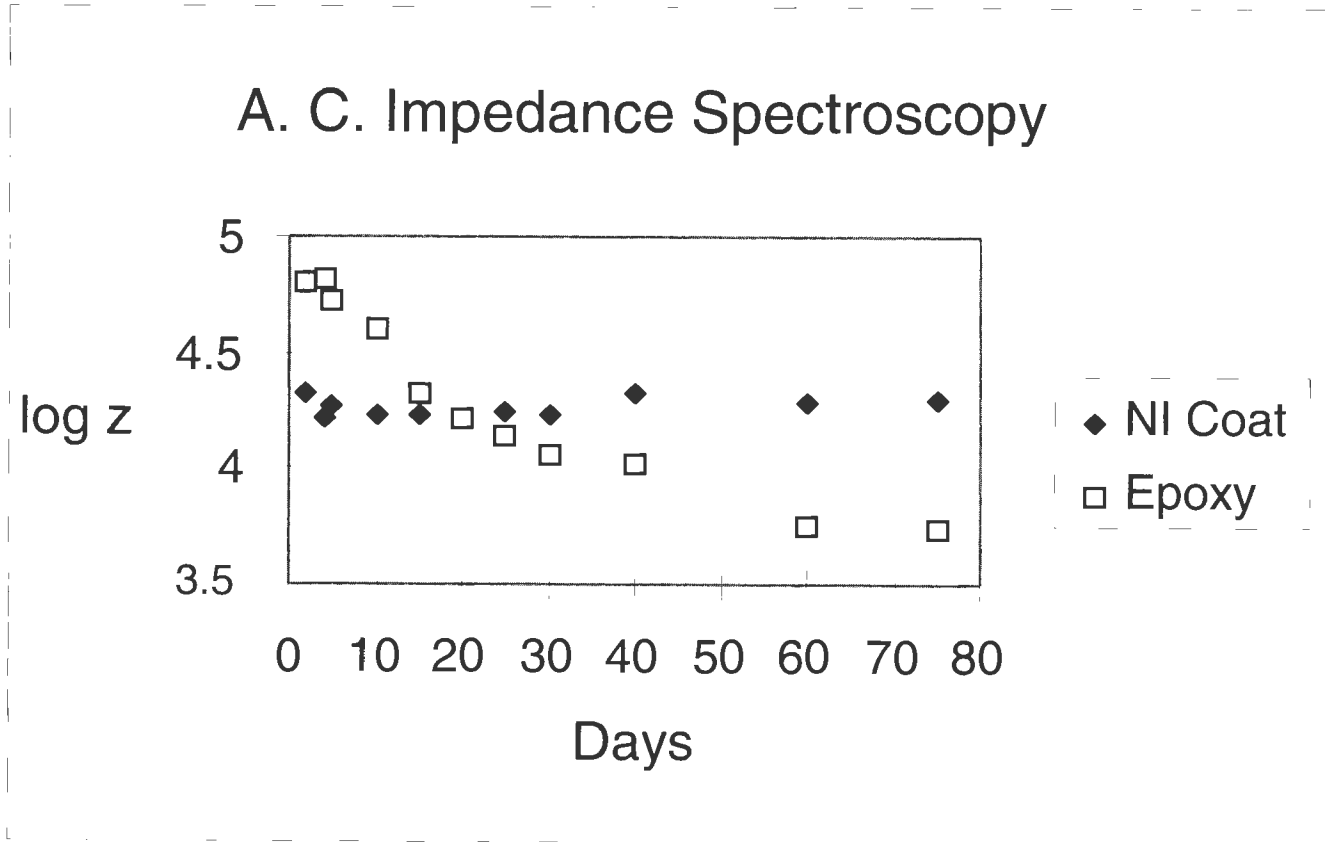

Figure 1

NI Coatings Outperform Epoxy Coatings in Exposure Tests

erably during exposure, its final impedance value was about 70,000 after 49 days exposure. After 49 days the most stable coating with the highest impedance was number 175, and so this coating was selected for ASTM-G109 concrete slab testing at the Florida Department of Transportation (FDOT) and the University of South Florida (USF). As a result of the unusual behavior of coating 206, USF and FDOT also requested a few sample bars of 206 for inclusion into the test matrix. Figure 2 shows a plot of the AC impedance data for 49 days exposure for five coatings, including 175 and 206.

ASTM B-117 salt spray testing was conducted on 5-in. lengths of 10 ICP-coated rebars and one epoxy-coated rebar obtained from a certified supplier. All samples had a single 1/16" hole drilled through the coating to the bare metal. After 27 days of salt spray exposure, several coatings exhibited initial corrosion in the 1/16" hole. These were numbered R2, R7, R8 and R9. The other samples R1, R3, R4, R5, R6 and R10 exhibited no corrosion in the 1/16" hole after 27 days. In all cases no separation or undercutting of the ICP coating from the rebar was observed. Rebars R1, R3, R5 and R10 showed no difference in behavior and so they could not be performance ranked to enable the selection of a single coating formulation. Digital images of these rebars showing shiny metal holes after 27 days exposure to 5% salt spray are shown in Figure 3. Epoxy coated rebar showed corrosion in the 1/16" hole during the first day.

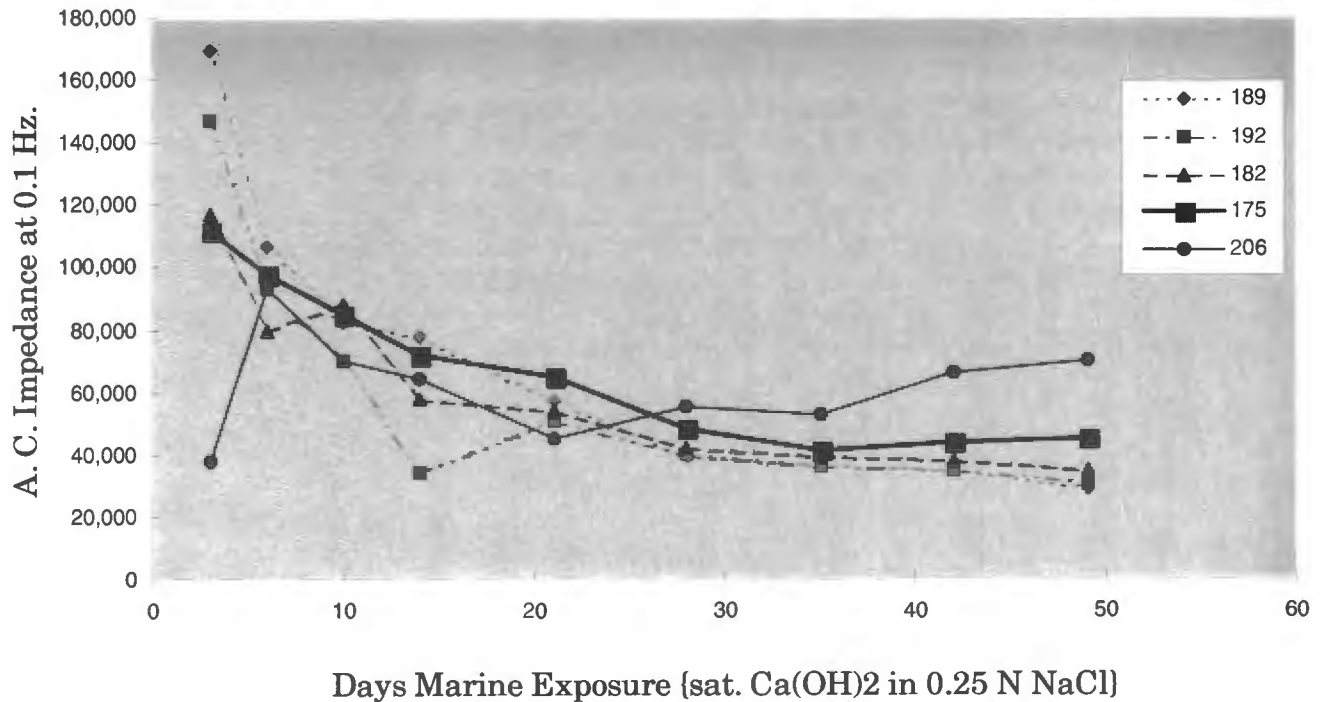

Figure 2

Corrosion Resistance Inorganic Copolymer-Coated Low Carbon Steel

FDOT, in conjunction with USF, have fabricated and begun testing of G-109 specimens that contain inorganic copolymer coated reinforcing bar (rebar). The purpose of these specimens is to evaluate the efficiency of this coating in the presence of sodium chloride (NaCl). Additionally, it is believed that this coating will passivate any damage the rebar may have suffered, such as that encountered in normal handling procedures.

The test matrix includes four types of rebar; (1) inorganic polymer-coated rebar type 1 (IPC1), (2) inorganic polymer-coated rebar type 2 (IPC2), (3) epoxy-coated rebar, and (4) plain rebar. All rebar used in the project was standard #4 (") diameter. Neely Industries, Inc. supplied all IPC rebar. Additionally, epoxy-coated rebar (Lilly Greenbar) was obtained from a certified manufacturer and shipped to FDOT laboratories. The test matrix uses Type II cement with a water to cement (w/c) ratio of 0.50. No pozzolans or corrosion inhibitors were used for this project.

The IPC rebar was sent from Neely Industries, Inc. cut to 13" lengths. At the FDOT laboratory, the necessary bars were damaged. Several bars (both IPC and epoxy coated) were experimentally damaged in areas that would not affect the integrity of the project. It was determined from the work plan that 10 areas per bar were to be damaged. The total area damaged is 0.25% of the total coating surface area. To achieve this it was necessary to use a 1/16" drill bit. However, to minimize crevice effects, the tip of the drill bit was ground down until it was flat. The damaged areas were located on the apex of the spiral ribs.

The G-109 specimens were cured in a form for 24 hours and then cured in plastic bags for 48 hours, after which they were placed into a moist cure chamber. All specimens were allowed to

mature for 90 days after casting before exposure to saltwater began. This added curing time was employed to ensure that some degree of concrete maturity is reached before saltwater exposure commences. This is believed to be particularly important given the accelerated nature of the tests. In order to establish the properties of the concrete used in the test specimens, the following tests have or will be conducted: rapid chloride permeability (RCP), compressive strength, length change, impressed current, and chloride content.

Baseline electrochemical data were collected after ponding with fresh water for one week. A 3% saline solution was then placed in the ponds to begin exposure to marine conditions.

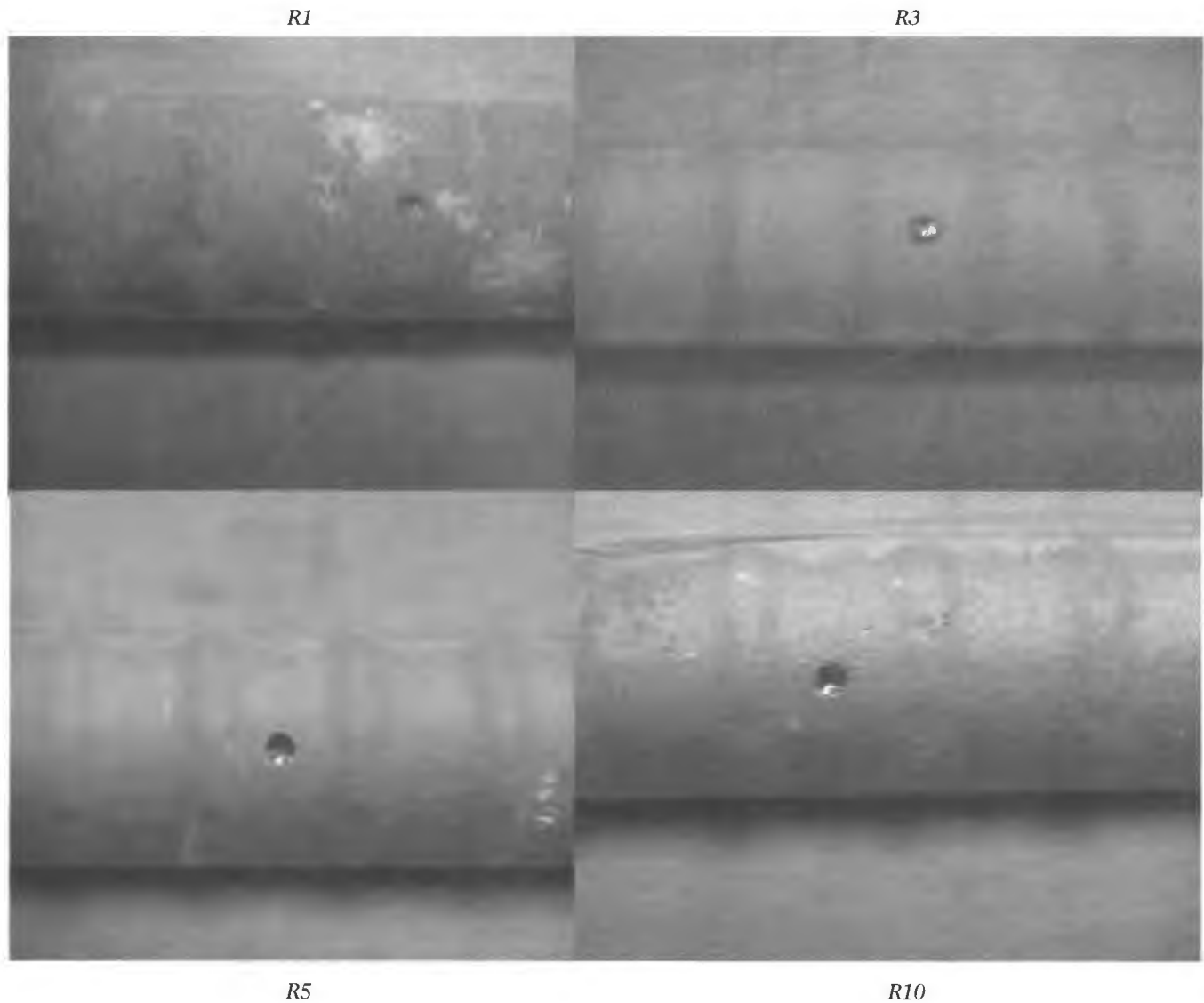

Figure 3

Inorganic Copolymer-Coated Rebars Showing No Corrosion in 1/16" Holes Drilled to Bare Metal and Exposed 27 Days to ASTM B-117 Salt Fog Test

As the G-109 specimens become active, a separate ponded specimen that contains no rebar will be analyzed to determine chloride content at a depth corresponding to the depth of the rebar. Testing will be discontinued on G-109 specimens as they begin to display outward signs of corrosion. The G-109 specimens will then be autopsied.

At the present time the corrosion resistance measurements remain high, thereby resulting in corrosion currents that are too low to quantify. An increase in the saline concentration from 3% may be necessary to accelerate the onset of corrosion. These results will be reported as they occur.

Product Payoff Potential

Commercial use of the coating is expected to provide corrosion protection to rebar with defects in the coating and to prevent undercutting of the coating that can have an adverse effect on structural integrity. The potential to lead to a breakthrough in the service life of coated and damaged rebar exposed to aggressive marine conditions in concrete structures is substantial. Increased service life and reduced maintenance costs would lead to substantial savings of state and federal funds. A reduction in the required thickness of the rebar coating is also anticipated along with a lower cost of the coating. This combination will provide a cost-effective solution to the current corrosion problems experienced in highway applications.

Product Transfer

A number of options for implementing the results within highway practice are possible. Once the new rebar coatings are shown to have superior performance over standard rebar coatings and are certified for use by the Federal Highway Administration and state departments of transportation, the next step for implementation to practice will be providing commercial quantities of inorganic polymer coatings. One option for Neely Industries, Inc. to provide commercial quantities of the coating would be by licensing the technology to established coating manufacturers, a strategy successfully utilized by NI. Discussions regarding the licensing of rebar coatings with companies that are interested in high-performance, environmentally friendly coatings are continuing. Another option to provide commercial quantities of the coatings is the formation of a joint venture company to manufacture the coatings. The manufacture of coated rebar will also be done by licensing regional fabrication and coating companies. As part of a private R&D effort, NI is currently planning coating application and processing trials at a Lane Enterprises, Inc. plant site. These activities will provide for the implementation of the results of this IDEA project.

A NOVEL APPROACH FOR PREDICTING REMAINING LIFE OF CONCRETE BRIDGE STRUCTURES

NCHRP-IDEA Project 54

C. S. Desai and T. Kundu, Department of Civil Engineering and Engineering Mechanics,
University of Arizona

Idea Concept and Product

Evaluation of the remaining life of materials in existing structures is vital for their safe operation and rehabilitation. Design of rehabilitation strategies requires the knowledge of the stress-strain-strength behavior of existing structures as affected by factors such as mechanical and environmental loadings. Here it is necessary to evaluate the elastic (deformation) constants (e.g., E and n), strength (e.g., peak strength), degradation (damage), and in some cases, stiffening (healing) properties. Although various nondestructive test (NDT) methods have been proposed and used in the past, they involve mainly the determination of the elastic moduli. No NDT method integrated with stress-strain or constitutive models are available to define the entire stress-strain response including deformation and strength parameters, and damage properties. In this research the recently developed Lamb wave technique and unified and powerful disturbed state concept (DSC) for material modeling will be combined for predicting remaining life of the material. The Lamb wave test data and the stress-strain data will provide the knowledge of disturbance (damage). Then this knowledge will be incorporated in the DSC model to obtain the stress-strain behavior and predict the remaining life. The end product will be a new field equipment that can allow definition of the parameters required for the assessment of remaining life of concrete and other materials.

Product Payoff Potential

Under the basic research stage of this project, the disturbance (damage) from the stress-strain and Lamb wave data will be correlated. This will lead to field applications of the concept, because the Lamb wave technique can be used in the field to evaluate disturbances at different times due to loads and environmental factors. Once the field disturbance is computed, it can be used to define the stress disturbance, which is then used to define the entire stress-strain response.

In addition to the novel integration of the nondestructive testing and constitutive model, this research would lead to a new and robust (commercial) equipment based on the Lamb wave technique. This equipment can be used readily for the measurement of disturbance (damage) in existing structures, over long lengths. Furthermore, it can lead to improved equipment compared to those based on other techniques such as the FWD (falling weight deflectometer), conventional ultrasonic technique, chain drag technique, radar technique, and magnetic resonance technique.

Project Results and Planned Investigation

Mechanical Testing: A number of test specimens have been loaded and unloaded in the MTS machine. A typical stress-strain curve showing both loading and unloading of a specimen is shown in Figure 1. The lateral strain versus the axial strain for the same specimen has also

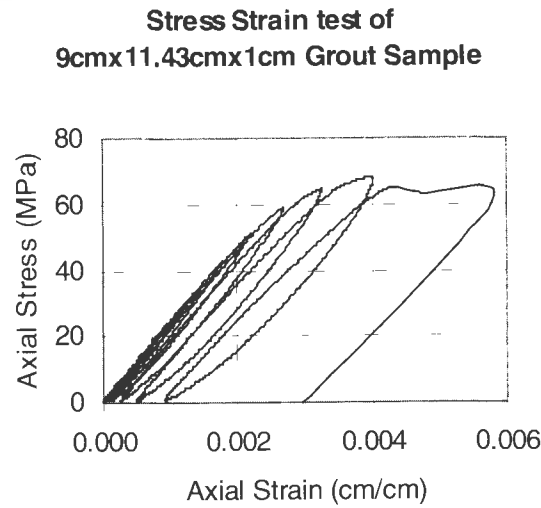

Figure 1
Stress-Strain Curve of Grout

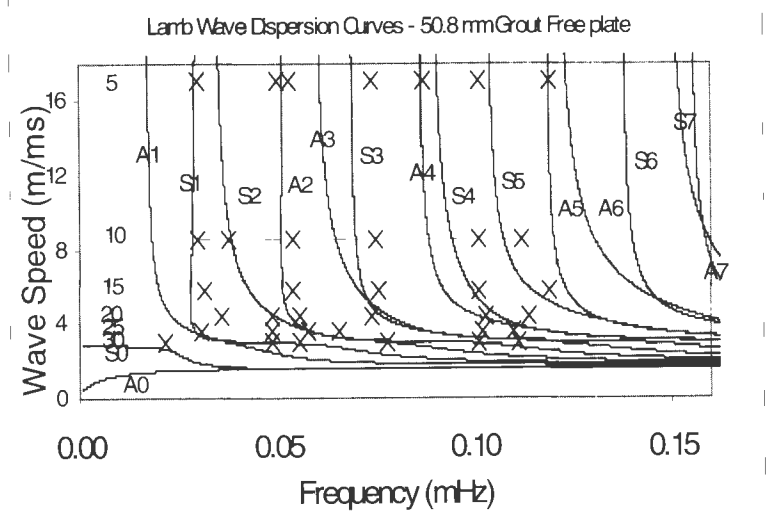

Figure 2
Lamb wave dispersion curves of grout slab

been plotted. Young's modulus (E) and Poisson's ratio (ν) obtained from these test results are 23.5 GPa (3.4×10^6 psi) and 0.25, respectively.

Lamb Wave Testing: Lamb wave dispersion curves for the same grout slab have been theoretically computed. Those are shown in Figure 2. These curves were generated for the grout slab with an E value of 23.5 GPa, $\nu = 0.25$ and thickness = 6 cm; these values were obtained from the mechanical test data. The slabs were then tested using the Lamb wave equipment; schematic of the transmitter (T) and receiver (R) arrangement and the specimen position is shown in Fig. 3. A special fixture for holding and rotating the transmitter and receiver was fabricated earlier. With this new transducer holder mechanism, the transducers could be inclined at any appropriate angle inside the coupling fluid container. Lamb wave was launched in the specimen by adjusting the transducer inclination angle and then continuously varying the signal frequency. The signal frequency was varied between 30 and 200 kHz. The received signal amplitude plot as a function of the signal frequency is called the $V(f)$ curve. Peaks in the $V(f)$ curves correspond to the Lamb modes. Phase velocity of the Lamb modes is obtained from the

Snell's law, $\theta = \sin \left(\frac{v_c}{v_{ph}} \right)$ where v_c is the longitudinal wave speed in the coupling medium be-

tween the transducer and the pipe, q is the transducer inclination angle and v_{ph} is the phase velocity of the Lamb mode. We have used water as the coupling fluid. Longitudinal wave speed in water is 1.49 km/s. Experimental values of the Lamb wave phase velocity are shown by cross marks in Figure 2. Angle of incidence (in degree) for generating these experimental points are shown near the vertical axis of Figure 2. These results prove that we could successfully generate and detect a number of Lamb modes in the grout slab. The matching between the theoretical curves and experimental points is reasonably good.

Our next objective is to carry out these mechanical and ultrasonic tests after the specimens have been aged by the chemical solution, and then compare those results with the ones for the

undamaged specimen. This would lead to correlation between mechanical and Lamb wave testing, and development of methodology for determining remaining life (stress-strain-strength response) of concrete.

Product Transfer

This research would allow evaluation of the remaining life based on parameters that can be obtained from standard laboratory stress-strain tests, and the nondestructive measurements. With the help of an industrial collaborator this research can lead to the commercial manufacturing of the Lamb wave– disturbed state concept (LW-DSC) equipment system, Fig.3, for field measurements of velocities and attenuation, leading to evaluation of cracking and damage, and stress-strain behavior. This equipment can provide robust and improved measurements of cracking and damage in concrete bridges, compared to those available today. The procedure and equipment can also be used for other materials such as metals and asphalt.

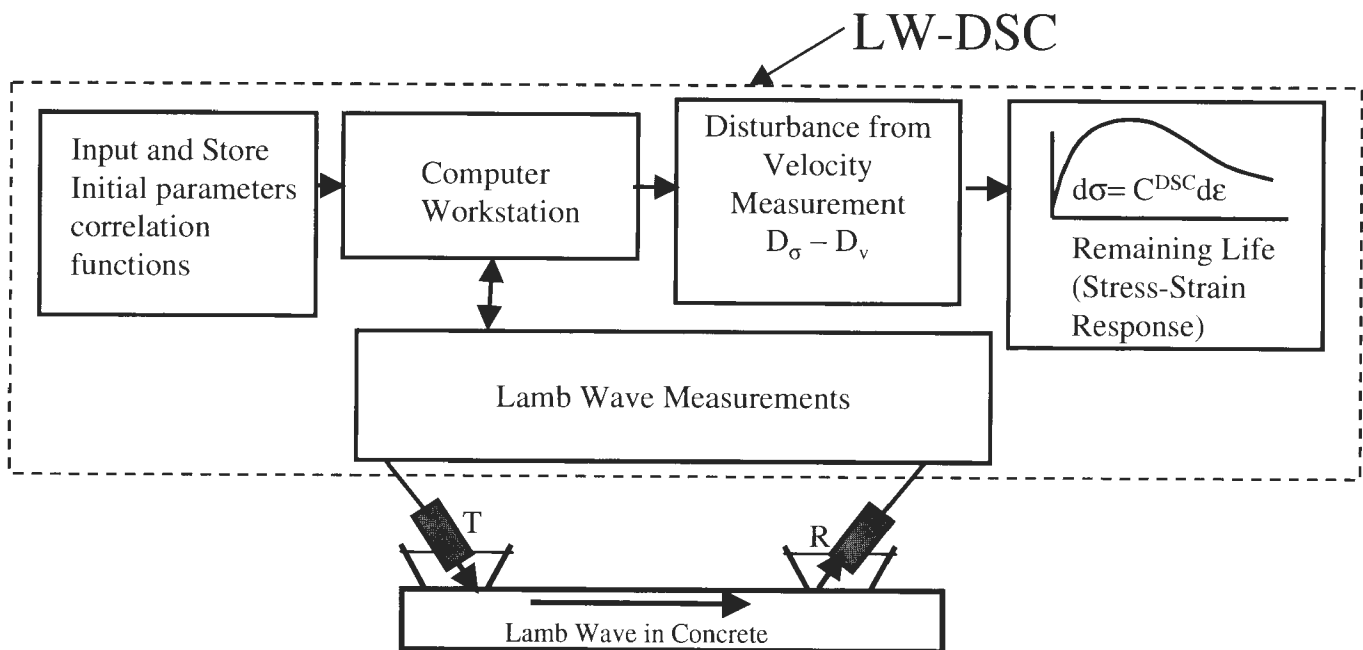

Figure 3

LW-DSC equipment for remaining life

DESIGN, DEVELOPMENT, AND VERIFICATION OF AN ADVANCED IN-SITU SHEAR STRENGTH TEST FACILITY FOR ASPHALT CONCRETE PAVEMENTS

NCHRP-IDEA Project 55

Abd El Halim Omar Abd El Halim, Carleton University, Ottawa, Ontario, Canada, Professor,
Department of Civil and Environmental Engineering.
Tele: (613) 520-5789, Fax: (613) 520-3951, Email: ahalim@ccs.carleton.ca

Stephen N. Goodman, Carleton University, Ottawa, Ontario, Canada, M.Eng. Candidate.
Tele: (613) 233-1961, Email sgoodman@ccs.carleton.ca

Wael Bekheet, Carleton University, Ottawa, Ontario, Canada, Ph.D. Candidate.
Tele: (613) 520-7471-1961, Email wbekheet@ccs.carleton.ca

Yasser Hassan, Carleton University, Ottawa, Ontario, Canada, Visiting Professor,
Department of Civil and Environmental Engineering.
Tele: (613) 520-2600 Ext. 8625, Fax: (613) 520-3951,
Email: yhassan@ccs.carleton.ca

IDEA Concept and Product

The Strategic Highway Research Program (SHRP) has recognized shear strength as an important indicator to predict rutting potential of hot-mix asphalt concrete (HMAC) pavements. However, current methods of measuring the shear strength of an asphalt mix have been limited to time consuming, expensive, or unrepresentative laboratory analysis. The concept of measuring the *in-situ shear strength* of an asphalt concrete pavement layer by applying a torque directly to the surface has been initiated at Carleton University in Ottawa, Canada. This concept allows relatively quick measurement of in-situ shear strength with a minimum of damage incurred by the pavement surface. A basic, first generation prototype called the Carleton In-Situ Shear Strength Test (CISSST) has yielded promising results relating the maximum applied torque to the shear strength of an HMAC layer. More importantly, the CISSST has determined that shear strengths achieved in the field are very different from those realized in the laboratory. These findings present strong evidence that the development of such a test device is required for more accurate measurement and performance modeling of in-service pavement performance—the fundamental basis of the SHRP Superpave system.

Project Results

The CISSST consisted of an electric motor mounted to a cart-like chassis as shown in Figure 1. A series of gears and driveshafts were used to transmit rotational force to a circular loading plate epoxied to the pavement surface. A torque cell and datalogger were used to measure torque while angle of twist at failure was measured with a protractor. Two test speeds were available. To prevent rotation of the test device during testing, six steel spikes were attached to the device and driven into the pavement. Test results achieved with the device yielded in-situ shear strengths of up to 300% greater than those achieved in parallel laboratory testing. However, a number of deficiencies were noted during initial investigations with the CISSST. Therefore, a comprehensive three-stage investigation was presented to the IDEA Program to continue the development of this innovative test device.



Figure 1

First Generation CISSST Prototype Test Configuration

The project was initiated in February of 1999. Within Stage 1, completed between February and June, three main objectives were addressed. These objectives were defined as (i) to carry out a critical analysis of the existing CISSST facility and determine its main deficiencies; (ii) to prepare a preliminary design of a second-generation shear test facility; and (iii) to develop a framework for a set of analytical models to predict pavement performance based on field shear data.

More specifically, the first objective involved a critical evaluation of the existing Carleton prototype. It was evident that problems associated with the weight of the facility, portability, stabilization, type of epoxy used, and lack of accurate control and data acquisition were among the most important deficiencies of the CISSST. The evaluation exercise provided a list of design objectives for the second-generation facility to significantly enhance its performance.

The second objective concerned the design of the new facility. The research team at Carleton University held a number of internal meetings to discuss a design approach to provide an optimum combination of the design objectives. The resulting new and improved facility has been dubbed the "InSiSST," an acronym for *In-Situ Shear Strength Test*.

Briefly, the InSiSST incorporates a trailer-mounted system for simplified transportation. A stable test platform is provided through a solid testing frame that is lowered to the ground via a jacking system. Positioning slides allow movement of the test motor and gearbox in the

longitudinal and transverse directions. Test measurements are recorded using a torque cell mounted to the testing plate, itself epoxied to the asphalt pavement surface. Control and data acquisition will be handled using a laptop computer and test software. In its current form, the InSiSST is able to perform five replicate in-situ shear tests each time the test frame is lowered, allowing more rapid testing and assuring statistical significance of the results.

The third and final objective of Stage 1 was to create a framework for a set of analytical models to ultimately predict long-term pavement performance of asphalt pavement surfaces based on results obtained with the InSiSST device. This framework consists of numerous tasks to ultimately achieve the goal of performance prediction. These tasks include the use of finite-element modeling to simulate the asphalt layer and loading conditions imposed by the InSiSST, observing and determining the resulting stress and strain behavior, calibrating the finite-element models with simplified closed form solutions and field data, and finally, predicting long-term pavement performance. The process of analytical modeling for this problem will be an on going process, requiring long-term performance data for model calibration not within the scope of this investigation. Stage 1 formed the foundation of the framework by presenting preliminary finite-element models of the pavement surface and various loading conditions. Based on the good correlation between the preliminary finite element models and closed form solutions for a simplified case, future modeling efforts will incorporate more complex viscoelastic material properties found in asphalt concrete. As field test results are gathered in Stage 3 of the project, the finite element models may be better calibrated.

Stage 2 of the project commenced in July 1999 and fabrication of the second-generation prototype test device is currently underway. Once constructed, a regime of "shakedown" testing will be completed to calibrate the test instruments and note any deficiencies in construction. Final adjustments will then be completed to prepare the device for the final stage of the investigation. Completion of Stage 2 of the project is scheduled for March 2000.

The third and final stage of the investigation will consist of two sets of field testing; one in Ottawa and the other TRB selected site. Analysis of the results will take on numerous forms. The first analysis phase will confirm that the field test is repeatable and consistent. Next, the field results will be compared to replicate laboratory test results to observe if a common factor, or "multiplier", exists between them. The sensitivity of in-situ shear strength to critical factors such as mix parameters, traffic level and temperature will also be analysed. Finally, the results will be used to calibrate the analytical models developed. The project completion date is scheduled for August 2000.

Product Payoff Potential

The successful measurement of in-situ HMAC shear properties and the development of a mainstream test facility would yield significant and immediate benefits to transportation practice. These benefits would be realized in three primary areas of pavement engineering. The first area is *design*. Utilization of the InSiSST in conjunction with laboratory testing would be a powerful combination for analyzing the potential of proposed mix designs. The second area is *quality control*. Newly constructed asphalt pavements could be tested to verify acceptable construction practices through the measurement and comparison of in-situ strength parameters with code requirements. The final area is *long-term pavement performance (LTPP)*. Monitoring field shear strength of pavements with time would allow periodic updating of initial performance models to more accurately predict future pavement performance. This, in turn,

would allow for more efficient allocation of limited rehabilitation funds and also help determine the effect of real world conditions, such as environmental factors, on pavement performance.

Product Transfer

The potential for a simple yet extremely effective in-situ test device has already drawn significant interest from both government and private industry. In addition to IDEA Program funding, the Ontario Ministry of Transportation and Regional Municipality of Ottawa-Carleton have committed financial and in-kind support for this investigation. Furthermore, a number of independent consultants have also expressed interest in the potential of the InSiSST. To facilitate a more smooth transition into mainstream use, these consultants have continued to be included during the development of the test facility. Their role has initially focused on technical advice; however, the consultants are expected to acquire the technology upon completion of the investigation. Continued evaluation and assessment of market potential will be the primary focus of consultants at that stage.

BRIDGE INSPECTION WITH SERPENTINE ROBOTS

NCHRP Project 56

Professor Howie Choset, Department of Mechanical Engineering, Carnegie Mellon University

IDEA Concept and Product

Federal law mandates that each bridge spanning more than 20 feet be inspected once every two years. Currently, rigging and traffic control consumes 40-50% of the bridge inspection cost. Rigging and traffic control are so excessive because the inspector has to see all locations of the bridge, which are often hard to reach on large bridges. This research will develop an innovative technology that resolves these shortcomings. Instead, an inspector, sitting in a truck on the bridge roadbed, will control a *serpentine* robot that can 'view' the entire bridge through a sensor suite deployed at the end of the robot. This system would reduce the cost of bridge inspection, increase the safety factor, provide better views of the bridge, improve the quality of information, and as an added benefit, decrease traffic delays that are a result of such an operation. The main challenges of the project are to design a new prototype and develop control strategies to move a serpentine robot through the trusses of a bridge.

Current Work

Control of serpentine robots is difficult because a planner must account for all of the joints (degrees of freedom) of the mechanism. The coordination of these numerous joints is not handled well in traditional robot motion planning theory. In the proposed work, the robot will use a roadmap, a geometric structure used in the robotic motion planning field, to plan the paths for the robot, which guarantee that its sensors 'see' all locations of the bridge with the



Figure 1

JPL serpentine mechanism inspecting a bridge.



Figure 2

JPL serpentine mechanism inspecting a collapsed building.

sensor suite. Typically, the roadmap can be derived from a CAD model of the bridge, but if no such model exists, then the serpentine can construct the roadmap from sensor data, as it inspects the bridge.

Two theoretic results occurred thus far: first, computing geometric structures in manmade environments is difficult because they possess symmetries that conventional geometric algorithms cannot handle. We overcame this problem and perhaps have identified a new fundamental method for constructing geometric structures in man-made structures.

Second, we have identified a new method for using roadmaps to perform path planning with snakes. We have not fully developed this method, and in fact, it is only in its infancy stages right now. The research focuses on the fact that different areas in the snake's workspace are more easily reached than others. The areas where the snake can reach the most easily are termed 'hot spots'. Judicious design and placement of a snake can take advantage of these regions. We believe that this science will enable snake robots to perform search and rescue missions more easily.

Finally, we have been designing a new snake prototype. Right now, the design space needed for a snake robot is being defined. Once this is understood, a locally optimal design will be chosen and a one-bay prototype built.

The developments arising out of this proposal are the first step towards the envisioned bridge inspection and other similar systems. The developments are critical to the successful transfer to an application program in the field.

Currently, the project is in the early phase of development. A standard PC-clone now controls the JPL robot through custom hardware developed by the Principal Investigator's lab. The snake robot was retrofitted with a camera, so now the inspector can view the bridge from a remote location. See Figure 1.

Project Transfer

1. Bridge Painting. Spray painting requires depositing a uniform thickness of paint on each target surface. A large expense of painting derives from the size and complexity of the object to be painted. Bridge painting involves extensive labor, support structures, health risks, and time. A serpentine robot could bypass these dangers and reduce these costs by matching a human painter's versatility while adding automation to the process. The motion planning and demonstration of bridge inspection is a necessary component for a bridge painting system, and thus bridge inspection is an excellent sub-goal that will lead to a bridge painting robot.

The results of this work are not limited to bridges and have potential use in outer space and manufacturing.

2. Space Robots. Maneuvering through three-dimensional tightly packed volumes necessitates a serpentine robot. The possible use of snakes to retrieve samples in fissures on Mars is being explored with NASA.
3. Search and Rescue. The recent Turkish earthquakes serve to remind us all of the need for better methods to search through rubble for survivors of building collapses. Serpen-

tine mechanisms are uniquely qualified to surgically enter unknown areas with little free space between obstacles.

4. Pipe Inspection. Serpentine robots can use their many degrees of freedom to reach deeply into a complicated network of pipes without damaging them, just as a surgeon can use an arthroscopic surgical instrument to make repairs inside the body without damaging it. Using the methods in this work, serpentine robots can perform inspection, maintenance, and repair deep inside a pipe network without having to excavate any roadways to find the location.

STABILIZATION OF LANDSLIDES USING WICK DRAINS

NCHRP-IDEA Project 57

Paul M. Santi [Tel: (573) 341-4927, Fax: (573) 341-6935], Assistant Professor, Department of Geological Engineering

C. Dale Elifrits, Professor, Department of Geological Engineering, University of Missouri-Rolla

IDEA Concept and Product

A method has been developed to use soil wick drains for a novel application of landslide and slope stabilization. Wick drains are flat, fabric-coated plastic channels, which were initially developed to be vertically driven into the ground using a specially adapted crane. The wick drains accelerate consolidation and settlement by an order of magnitude by significantly shortening the flowpath for water to exit a soil layer. They were first developed in the 1930s and have found widespread use since the 1970s, when durable plastic came into use, replacing the cardboard channels originally used. This study has developed equipment to install wick drains horizontally, so that they might be used to drain landslides. Drains have been installed in several instrumented landslides to prove the effectiveness of the procedure.

The method of installation is to use a bulldozer or hydraulic excavator to push a small-diameter steel pipe into the hillside (Figure 1). The pipe sections are preloaded with a continuous wick drain, which is attached to a disposable drive plate at the front end of the pipe. At the target depth, the pipe is withdrawn, leaving the wick drain in place. The method of driving steel pipe with bulldozers has been used in Missouri to drive retrofitted drainage pipes into stock ponds. Pipes have been driven at upward sloping angles, through native soils and pond berms, for distances as great as 150 feet.



Figure 1

Installation of horizontal wick drains using a small bulldozer and 2" diameter drill pipe containing the wick.

Product Payoff Potential

Current highway practice in mitigating landslides is cost- and time-intensive. Stabilization of active landslides involves significant earthmoving, drilling, or construction of drainage or buttress features. Movement of ground not originally recognized as active landslides results in repair expenses and road closure.

This proposed method of landslide stabilization is expected to be so simple and cost-effective that practitioners will apply it as an “insurance factor” for marginally stable slopes that otherwise would be ignored. As a result, not only will known landslides be addressed more quickly and cost-effectively, but fewer unpredicted landslides will occur. Hence, roads will require less maintenance and experience fewer closures.

An example of the potential cost savings is shown by comparing wick drain installation to horizontal hydraugers, which are currently used to drain slopes. Horizontal hydraugers cost an estimated \$6-11 per foot in 1980 [1, 2] and horizontal wick drains have been installed for this project at roughly one-fourth of that cost range. In addition, wick drains are encased in a geotextile fabric that serves as a filter and prevents clogging of the drains by fine soil, which is a problem with the slotted PVC pipe used in hydraugers.

Project Results

A 60-yd³ test embankment was constructed with a 1:1 front slope to verify wick spacing design and the effectiveness of the wicks to convey water out of the slope. The embankment was instrumented with piezometers, soil moisture meters, and survey markers. One-half of the slope was stabilized with six wick drains. The other half of the slope was not stabilized, so that it could be used as a control point in the experiments. Once a ground-water table had been developed in the slope by induced infiltration, the slope was watered with sprinklers to simulate a 100-year 24-hour rainfall (7.5”). During this simulation, water levels, wick drain discharge, and slope movement were measured and recorded.

The results of the test embankment simulations verify the effectiveness of the wick drain system. The wicks showed substantial water flow, the piezometers on the stabilized side of the embankment showed significantly lower water levels than the unstabilized side, and the survey stakes on the stabilized side showed approximately one-third as much settlement and movement as the unstabilized side.

In addition to the test embankment, six landslides have been stabilized using wick drains. In Missouri, these included a fill embankment near Boonville on Interstate 70, stabilized with 10 drains ranging from 20 to 40 ft in length, and a natural loess slope in St. Joseph on I-229, stabilized with six drains approximately 50 ft long. This work was conducted in cooperation with the Missouri Department of Transportation.

In Colorado, four landslides were stabilized. On Highway 13 near Rio Blanco, six drains 50 ft long were installed. Near Meeker, on the same highway, 11 drains 50 to 80 ft long were installed in two separate landslides (Figure 2). Near Rye on Highway 165, 24 drains 20 to 40 ft long were installed. All landslides were stabilized in cooperation with Colorado Department of Transportation and Colorado Geological Survey personnel. The Rio Blanco and Meeker slides were stabilized with CDOT equipment and using CDOT workers with minimal training in the installation technique. The Rye landslide was stabilized by Nilex Corporation, which manu-

factures and installs conventional wick drains. Nilex used a Caterpillar 215B hydraulic excavator and mandrel/crane attachment normally used to drive vertical wick drains, but reconfigured to drive horizontally.

The landslides are currently being monitored to track water levels, slope movement, and roadway movement to verify the effectiveness of the wick drains. The test embankment and all stabilized landslides will be analyzed using a three-dimensional slope stability computer model coupled with field observations and laboratory strength tests. The computer models will be calibrated for each site using pre-stabilization conditions, and then the predictive ability of the computer models to simulate post-stabilization conditions can be tested. In this way, the effectiveness of the stabilization program will be evaluated, guidelines for computer modeling of horizontal wick drains can be created, and generalized installation layouts for horizontal wick drains can be suggested.

Product Transfer

The use of horizontal wick drains could revolutionize the way we deal with landslides. The results of this study will provide a clear, defensible analysis of equipment preparation, drain installation, and drain effectiveness. The investigators are performing landslide stabilization in cooperation with the American Wick Drain Corporation, the Nilex Corporation, the Colorado Geological Survey and the Missouri and Colorado Departments of Transportation. A demonstration video is in preparation to show the installation process and equipment, and a panel of experts will provide feedback on the commercial viability of the system.

Follow-up work will identify more robust wick driving systems, quantify wick clogging rates, explore methods of emplacing sand filters around the drains, and measure wick drain effectiveness in a variety of geologic settings and under a variety of slope geometries.

References

1. Ruff, W.T., 1980, Mississippi's Experience with Horizontally Drilled Drains and Conduits in Soil: *Trans. Res. Rec.* 783, pp. 35-38.
2. Trolinger, W.D., 1980, Rockwood Embankment Slide Between Stations 2001+00 and 2018+00: A Horizontal Drain Case History: *Trans. Res. Rec.* 783, pp. 26-30.

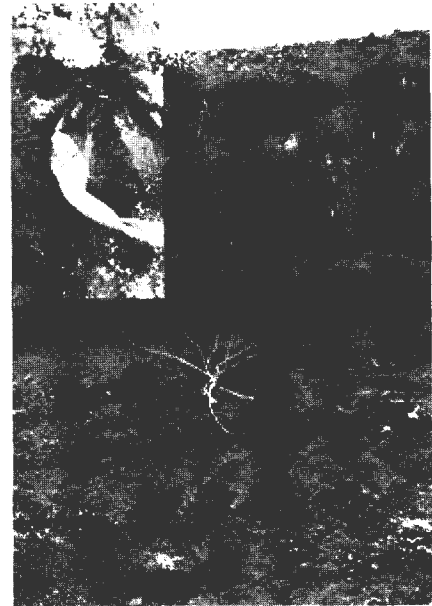

Figure 2

Completed landslide drain system in a fan pattern. Note the water exiting the wick drains (Inset: Close-up of water drainage from a wick drain).

LONG GAUGE-LENGTH INTERFEROMETRIC FIBER-OPTIC SENSORS FOR CONDITION ASSESSMENT OF BRIDGE STRUCTURES

NCHRP-IDEA Project 58

Jeffrey A. Laman [Tel: (814) 863-0523], Assistant Professor, Department of Civil & Environmental Engineering, Pennsylvania State University, University Park

Timothy E. McDevitt, Research Associate and Assistant Professor of Acoustics, Pennsylvania State University, University Park

Karl M. Reichard, Research Associate, Applied Research Laboratory, Pennsylvania State University, University Park

This IDEA project began on December 1, 1999.

IDEA Concept and Product

This IDEA project encompasses the research, development, and refining of a long gauge-length, optical fiber-based sensing system to be used for the assessment of bridge structure condition and damage detection. To date, short gauge-length, or point, sensors have been proposed for detecting damage; however, the inherent difficulties in selecting appropriate sensor locations in advance of damage have limited the success of previous systems. Two distinct detection system innovations will be derived from the current project: a robust optical sensing system and a long gauge-length sensor. In conjunction with implementation of the new sensing system, previously established as well as innovative damage-detection techniques will be evaluated for compatibility with the proposed system.

Product Payoff and Potential

The research program has been designed as a sequence of research and development consisting of (a) interferometric sensor design, (b) engineering of a fiber-optic-based condition assessment system, (c) development and evaluation of damage detection techniques, and (d) full-scale implementation of the system and damage-detection methodologies on an existing bridge. The project consists of three phases: Phase I was the planning phase, Phase II is the laboratory study (see Figure 1), and Phase III consists of the field study. Tasks for Phases II and III were designed and developed in conjunction with the advisory group as part of Phase I. Phase II consists of a laboratory study on a concrete test structure and Phase III consists of a full-scale test and implementation of the system on an existing concrete bridge structure. The research program is designed to determine the relationships between the configuration of a long gauge-length fiber-optic sensing system and the ability to detect damage in large civil structures. The system has been developed and optimized in the laboratory as part of Phase II. It is expected that this system will be a critical link in the ongoing development of improved bridge management systems and have the potential to be integrated into structural control and smart structural systems. Significant long-term benefits will be derived from the incorporation of advanced technologies into traditionally low-technology structures where issues of advancing network maintenance efficiency and overall safety are a priority.



Figure 1
Test Structures.



Figure 2
Optical Light Source.



Figure 3
Detector Enclosure.

Project Planned Investigation

A study of long gauge-length, fiber-optic sensors has been conducted by the research team as part of Phase I and II. A dual-mode, long gauge-length fiber system has been developed (see Figures 2 and 3). The interferometric system of strain measurement is used to measure dynamically induced strains along the structure. Damage will be induced to the structure during the measurements. Correlation coefficients of the frequency response functions between the various damaged states and the baseline, undamaged state were calculated from the response. There is a very discernible pattern of frequency response function shifts as the damage progresses, demonstrating that the long gauge-length sensor has promise in the proposed application.

Methodology and Plan of Work

The study consists of three phases. Phase I consists of finalizing the project design in conjunction with a regional advisory group. Phase II consists of laboratory research conducted to establish the major components of the fiber-optic-based system, develop the damage-detection analytical process of pattern recognition (see Figure 4), and develop a rugged and reliable

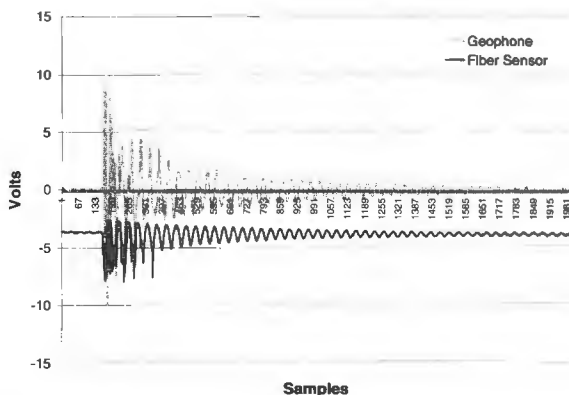

Figure 4
Time History of Sensor and Geophone

field system. Phase III testing will be conducted at an in-service highway bridge site in Central Pennsylvania on Rte. 220 by instrumenting the existing concrete T-beam bridge (see Figure 5) with the prototype fiber-optic-based condition assessment system.

Phase I

Major testing objectives and research program design have been finalized during the first phase of the work. Objectives, system design, and signal processing techniques have been established for both Phase II and Phase III. The research program was presented to and discussed with a regional project advisory group. The final methodology and plan of work was developed to guide Phases II and III test programs.

Phase II

The fundamental testing in Phase II optimized several features of the system, particularly as they relate to concrete bridges:

1. Evaluated several adhesives for characteristics of bond, ease of application, and cure rates.
2. Evaluated commercially available fiber types specified with different combinations of cladding diameter, jacket diameter, operating wavelength, polarization, and core and cladding degree and composition of doping for suitability to the proposed application.
3. Evaluated several light input sources, including lasers and light-emitting diodes.
4. Evaluated commercially available photo-detectors for sensitivity and suitability to the application.
5. Identified the influence of temperature sensitivity on the process of damage detection and condition assessment and identify methods of including a reference fiber in the system to delete temperature effects.



Figure 5

West Elevation of Bridge 14-0220-0350-0690.

Phase III

Phase III will consist of testing an in-service Central Pennsylvania concrete highway bridge by instrumenting the bridge with the prototype fiber-optic-based condition assessment system. PennDOT vehicles will be available to load the bridge during controlled testing. This phase will consist of several tasks:

1. Evaluate and further develop the system for field applications.
2. Evaluate the durability of the system under highway conditions.
3. Evaluate the data and repeatability of the testing.
4. Evaluate the static and dynamic response measurement capabilities.
5. Evaluate the ability of the system to report thermal response of the structure.

Product Transfer

This project consists of development and demonstration of the optical fiber-based instrumentation and data reduction methodologies needed to mitigate deterioration and damage to highway bridges. The proposed research will result in the application of advanced diagnostic technologies that will enhance early detection of deterioration and thus may reduce the time between repair and resumption of service. Publication of research results in the form of an NCHRP report, in TRB special reports, and in other technical journals will be undertaken by the research team to further the transfer of knowledge gained through the proposed research. It is expected that the successful completion of this research will facilitate a more extensive demonstration project in cooperation with state departments of transportation and FHWA. This will result in the implementation of the technology developed during the present study on either existing or new concrete and/or steel bridges and generate increased interest in the proposed concept as a viable methodology for highway bridge damage detection and condition assessment. Ultimately a rugged, reliable, portable, and remote monitoring system is envisioned that may be prototyped for use and potentially result in a product deployment.

CONTROL SYSTEMS FOR LIVE LOAD AND LIVE LOAD EFFECTS ON BRIDGES

NCHRP-IDEA Project 59

Andrzej S. Nowak, University of Michigan

IDEA Concept and Product

The objective of the study is to develop an integrated system for monitoring live load and verifying live load carrying capacity of highway bridges. Therefore, the proposed research will deal with the development of the control system for live load on bridges and the control system of live load carrying capacity. The anticipated major contributions will include:

- the improvement of field testing procedures using remote sensors and transmitters (e.g., site-specific weigh-in-motion measurement of trucks, component-specific fatigue load spectra),
- on-site processing of the data,
- calculation of critical truck loads (illegal overloads),
- accumulated fatigue load spectra,
- maximum deflection,
- derivation of reliability-based criteria for acceptability limits (truck weight, axle load, number of load cycles, deflection),
- elements of active control with on-site response to critical overload as determined by comparison with the developed reliability-based criteria (e.g., illegal truck, exceeded fatigue load limit),
- integration of truck weigh-in-motion with diagnostic testing (e.g. to verify load distribution factors) and proof load testing (to verify the minimum live load carrying capacity),
- derivation of reliability-based criteria for establishing proof load level for bridges.

The proposed research will be based on the experience gained in an extensive field testing program and bridge reliability analysis at the University of Michigan.

Research will be carried out in two major directions. The first one is the development of a load measurement system, with motion sensing detectors, strain gauges, accelerometers, and remote sensing devices (laser-based optical devices). The system will provide information about the vehicles (truck weight, axle loads, axle configuration, speed, multiple presence). The load effects (moment, shear force, stress, strain and deflection) will be calculated and recorded. Critically overloaded trucks will be identified. The system will also determine component-specific fatigue load spectra. Critical load levels will be determined based on the reliability analysis. The other direction is the development of a diagnostic system for verification of structural capacity to carry live load. The system will include field testing procedures, signal processing procedures for identification of critical changes in the resistance, and selection criteria for proof load level(s). The traffic load data monitored by the first system will be used as input for the bridge diagnostic system. The major indicators will include load distribution factors, natural frequency of vibration, and deflection. Proof load tests will be integrated into the diagnostic system. The proof load level will be determined based on the reliability analysis.

Project Results (or Planned Investigation)

The objective of this project is to develop an efficient control system for highway load effects. The system involves the control of various parameters including:

- truck weight (axle weights and axle spacing)
- truck frequency of occurrence (average daily truck traffic, ADTT)
- vehicle speed
- vehicle position within the width of the bridge
- strain, stress, and deflection of bridge components

Therefore, an important part of the project is to develop a procedure for evaluation of live load spectra on bridges. Truck weights, including gross vehicle weight (GVW), axle loads, and spacing are measured to determine the statistical parameters of the actual live load. Stress is measured in various components of girder bridges to determine component-specific load spectra.

However, the truck weight measurement results should be unbiased. It has been observed that drivers of illegally overloaded vehicles avoid highways with truck weigh stations. Instead, they use alternative routes to avoid citation. Yet, truck weigh stations serve as a major data source. Therefore, little reliable truck weigh data is available to bridge researchers and designers. Also, past studies performed in other states did not provide reliable results due to errors in the data collection. In this project, the measurements are taken so that drivers are not aware of the presence of the WIM equipment. A considerable unbiased database has already been developed.

This study involves experimental and analytical efforts. A live load model is developed on the basis of WIM measurements, truck counts, truck surveys, and statistical analysis. The development of control systems for highway load effects requires expertise in bridge analysis, load modeling, remote sensing, and signal processing. Bridge load spectra are considered in terms of moments and shears. Moments and shears for various span lengths have been calculated for each truck in the database. Measurements were also carried out to determine load spectra for components (girders and diaphragms). The results indicate that load spectra are component-specific. This observation is important from the fatigue analysis point of view.

The work has been focused on the integration of WIM measurements with bridge evaluation, and use of proof load testing in bridge diagnostics. The proposed system has been applied to about 20 bridges located in Michigan. The selected structures carry interstate highways, state highways, and surface streets. Several bridges have been also selected for proof load testing. These tests are used as an efficient tool in bridge diagnostics. Field testing equipment includes two data acquisition systems, portable computers, strain gauges, infrared beams, accelerometers, LVDT's, dedicated van, and other items. The equipment was calibrated using a truck with known GVW, axle weights, and axle spacing.

The WIM data provide unbiased results because the drivers are not aware of the measurements and therefore they do not make any effort to avoid the scales. The heaviest truck recorded in the WIM survey was over 250 kips, and the heaviest axle load was about 50 kips. The results of tests include GVW, axle weights, and stress spectra. The obtained results clearly point out that truck loads are strongly site-specific. Law enforcement level is a deciding factor. Bridges

located near the truck weigh station carry truck loads that are very close to the legal limits. On the other hand, bridges located far away from the stations (inefficient law enforcement) are subjected to considerable overloads.

In the study, bridge load spectra are considered in terms of moments and shears. Moments and shears for various span lengths have been calculated for each truck in the database. A considerable effort was also directed to establish component-specific load spectra. The measurements indicate that fatigue loads vary from girder to girder. Therefore, truck load effect control should be focused on the most loaded components.

An efficient approach to control of the load carrying capacity is proof load test. This is particularly important for bridges that are difficult to evaluate by analysis (missing drawings, visible signs of deterioration such as cracking, corrosion, and/or spalling concrete). Proof load tests were carried out on five bridges. The selected structures include two reinforced concrete T-beam bridges, and three steel girder bridges. The span range is between 20 and 50 ft. All tested bridges are located in Michigan.

Bridges were selected for proof load tests because of low rating factor, visible deterioration (corrosion), or lack of documentation. Two structures were repaired and proof load test was used as verification of the repair efficiency. It was difficult to provide a load that is considerably higher than legal Michigan truck load. Therefore, military tanks were used from the National Guard. An M-60 tank weighs about 60 tons and the length of tracks is about 14 ft. The proof load level was determined by considering a load factor (1.4) and dynamic load factor (1.1-1.3), which results in almost twice the legal load.

Product Transfer

The results of this project are implemented on a regular basis. The project team works closely with the technical staff of the Michigan Department of Transportation (MDOT). The research work progress is presented at meetings and in monthly reports. In particular, practical needs are discussed to direct the research effort accordingly. The field work is carried out on bridges selected in coordination with MDOT. Some of the most efficient results, which have been already implemented, include WIM measurements and proof load testing. The developed procedure has been used by MDOT for evaluation of selected partially deteriorated bridges. The project work will continue for several months. Further work will be focused on the following items on the development of a remote sensing device for measuring lane-specific truck parameters, the development of practical procedures for active and passive control of truck load effects and continuation of the work on signal processing procedure to improve prediction of life expectancy and reliability of bridges structures based on WIM measurement data.

THE PAVEMENT THICKNESS DENSITY METER

NCHRP-IDEA Project 61

Dr. Kenneth R. Maser [Tel: 781-648-0440, fax: 781-648-1778], INFRASENSE, Inc.

Concept

The proposed PTDM will be a portable, easy-to-use device for automatically and nondestructively determining pavement thickness and density at the time of construction. The pavement thickness density meter (PTDM) overcomes the time and coverage limitations and safety requirements of traditional methods. It provides 100% coverage, which will enable highway agencies to locate and correct all areas of substandard pavement thickness and density.

Planned Investigation

In order to carry out the proposed work, *INFRASENSE* has put together a team of individuals and organizations with a unique combination of qualifications. The approach is to first develop specifications for the proposed system and then develop and evaluate the individual components that will meet these specifications. The assembled prototype will then be tested in the field in conjunction with paving projects and coordination with state highway agencies. The technology required for developing and implementing the PTDM has already been developed and utilized in other quarters. For example, pulsed electromagnetic systems (commonly referred to as "Radar" systems) are now being used routinely to measure pavement thickness. These systems, however, are cumbersome and expensive; consequently they are not routinely used by inspectors and technicians. The proposed PTDM seeks to package and implement this type of technology in a way that has never been done before.

The key technological innovations required for the development of the PTDM are:

- 1) implementation of smaller and more portable components, particularly the transmitting antenna;
- 2) implementation of software that automatically produces the readings that will be directly displayed for the operator; and
- 3) packaging of all of these components in a small portable device that can be easily used and handled as a routine piece of field test equipment.

The key components of the system and how they relate to one another are described using the schematic block diagram shown below:



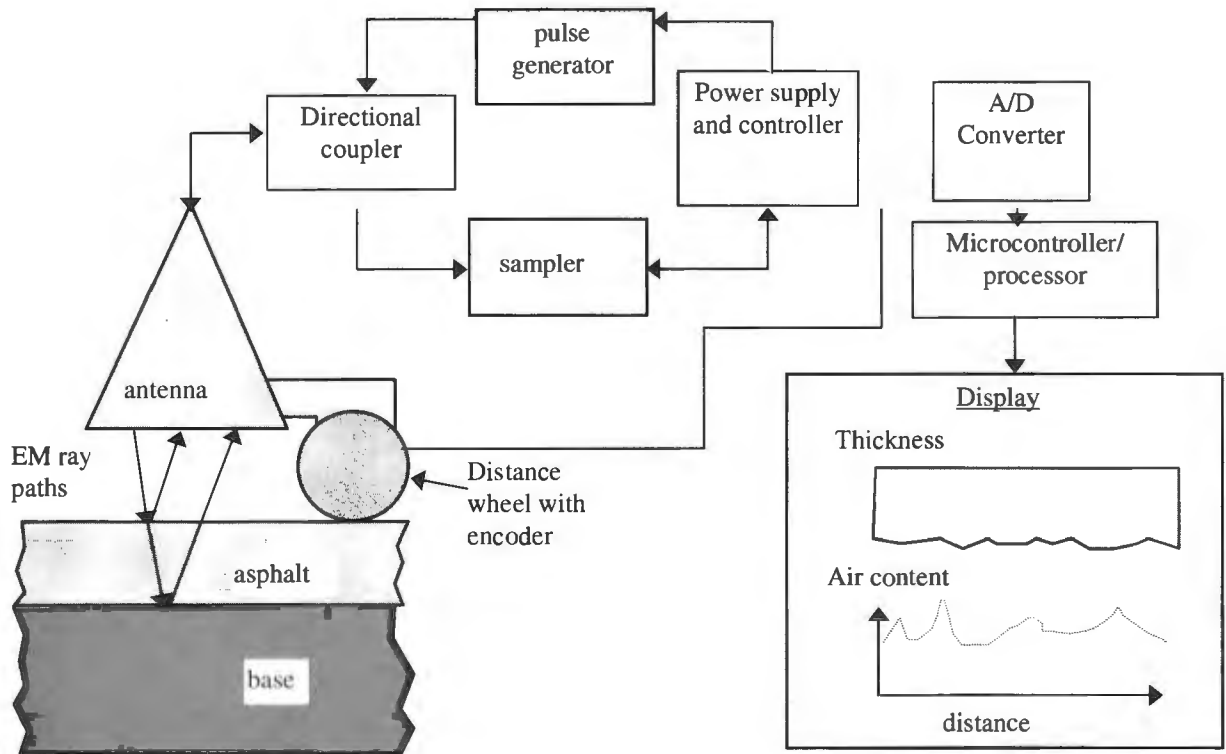

Schematic Block Diagram of PTDM

Payoff Potential

The PTDM will enable agencies to maximize pavement life and minimize life-cycle costs by accurately and completely determining, at the time of construction, if pavement has been built according to specifications. With this capability, agencies will be able to save millions of dollars in premature, unplanned, and unnecessary repairs and rehabilitation caused by inadequately constructed pavement.

The proposed PTDM would be available at a price comparable to other pavement nondestructive testing devices; and thus would be applicable for routine use by contractors, state highway testing organizations, and by private and contracted testing laboratories. This testing device would represent a strong force toward increasing the quality of construction.

Product Transfer

Should the results of this work prove favorable for commercial development, pre-production units would be fabricated for further demonstration and testing. The project team includes an equipment manufacturer who would fabricate these units, and who would ultimately manufacture the commercial device. The commercial PTDM would be marketed and sold through distribution means similar to those used for other pavement test devices.

A NEW TECHNIQUE FOR CHARACTERIZING PAVEMENT SURFACE PROFILES AND TEXTURES

NCHRP-IDEA Project 62

Cam Nguyen [Tel.: (409) 845-7469, Fax: (409) 845-6259],

Department of Electrical Engineering, Texas A&M University

Tom Scullion [Tel.: (409) 845-9913], Texas Transportation Institute, Texas A&M University

IDEA Concept and Product

This project aims to develop a very high-resolution millimeter-wave sensor and demonstrate its use in real time measurements of transverse and longitudinal profiles, micro/macro textures, and detecting areas of mix segregation in newly constructed asphalt surfaces. Compared to other technologies, millimeter waves have two uniquely distinct characteristics that can be exploited for nondestructive, high-resolution surface measurements: higher frequencies and larger absolute bandwidths. These characteristics together can produce a system that has very fine resolution and small size.

Planned Investigation

The project is divided into two stages. The first stage will involve development of the laboratory test specimens and development of the millimeter-wave sensor. In the second stage, we will evaluate the developed sensor in both laboratory and field tests.

Stage I

A series of representative lab specimens will be constructed to represent the range of pavements and materials to be found in the field. These new samples will be small in size, perhaps 1m x 1m. The samples will cover a range of macro and micro textures. Lightweight aggregate with very high polish values will be compared with rounded silicious river gravels.

A millimeter-wave sensor will be developed for nondestructive measurements of pavement surface characteristics. Performance of all individual millimeter-wave components and antenna will be fully tested and verified, then integrated to form a prototype millimeter-wave sensor.

Stage II

The prototype millimeter-wave system will be evaluated in Texas Transportation Institute (TTI) laboratories and facilities. Laboratory evaluation will be performed using test specimens fabricated in Stage I. The following tests will be conducted: measurement of pavement micro/macro texture, measurement of transverse pavement profile, and detection of segregation.

Then the millimeter-wave sensor will be evaluated in the field. As a first step, the sensor will be used at TTI's Riverside Campus to monitor the texture of the National Calibration skid pads. This will give a direct comparison between the surface texture and the known skid resistance value. There is also a plan to take the sensor to several recently completed hot-mix jobs to scan for possible segregation.

Product Payoff Potential

The sensors to be developed in this study will be capable of being installed in highway data collection equipment. They will provide critical inputs to pavement management systems in terms of pavement rut depths and skid resistance (from macro/micro). If successful, the segregation application will be a valuable tool for checking the quality of newly constructed pavements and new surfacings.

Product Transfer

TTI is working closely with the states of Florida, Texas, and North Carolina in implementing advanced technologies for pavement applications. These states, as well as others, are likely potential users of the proposed millimeter-wave system once it is developed, and serve as the bases for transferring the results to transportation practice. Toward this objective, research results will be disseminated to state and federal transportation organizations throughout the life of the project. Demonstrations of the new millimeter-wave prototype, once developed, will be made to these organizations and the investigators will help with implementing the results for transportation practice.

The DOTs of Texas and North Carolina have agreed to cooperate and support this development effort, and have expressed strong interest in using the new millimeter-wave system. TTI will also make available to the project's research team access to its National Skid Resistance test site at the Texas A&M Riverside campus and also the recently constructed TTI roughness calibration facility. These are actual pavement sections with either known surface characteristics or known rut depths.

MANUFACTURE AND TESTING OF A FILAMENT-WOUND COMPOSITE BRIDGE SUPERSTRUCTURE

NCHRP-IDEA Project 63

D. Parsons [Tel: (217) 333 2690, Fax: (217) 333 9464, E-mail: mdp@uiuc.edu],
Associate Professor of Civil Engineering, University of Illinois at Urbana-Champaign;

Scott White [Tel: (217) 333 1077, Fax: (217) 244 0720, E-mail: swhite@uiuc.edu],
Associate Professor, Department of Aeronautical and Astronautical Engineering,
University of Illinois at Urbana-Champaign

IDEA Concept and Product

This project will investigate the manufacturability and the structural performance of the composite bridge superstructure shown in Figure 1. The bridge consists of two components: a series of inner cells, lying parallel to the direction of traffic, and an outer shell. Special consideration was given to three factors when this design was developed. First, filament winding was chosen as the basic manufacturing procedure, since it allows for automated manufacturing, with faster fabrication cycles and reduced manufacturing costs. Second, attention was given to the transfer of shear between the different components; the oval inner cells provide sufficient contact area to reduce the shear stress to acceptable values. Third, additional stiffness and strength was developed by incorporating shell behavior into the structure, rather than relying solely on plate bending common in standard bridge deck designs. Shell action is obtained by providing contact between the inner cells.

Planned Investigation

The proposed research consists of two parts: the manufacture of several small-scale models of the proposed composite bridge, followed by experimental testing of the models.

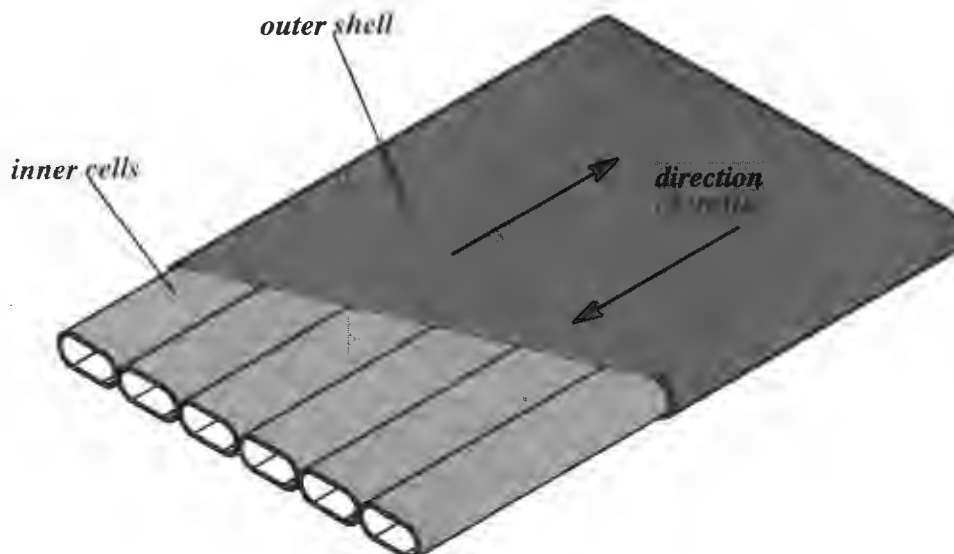

Figure 1

Bridge structural system.

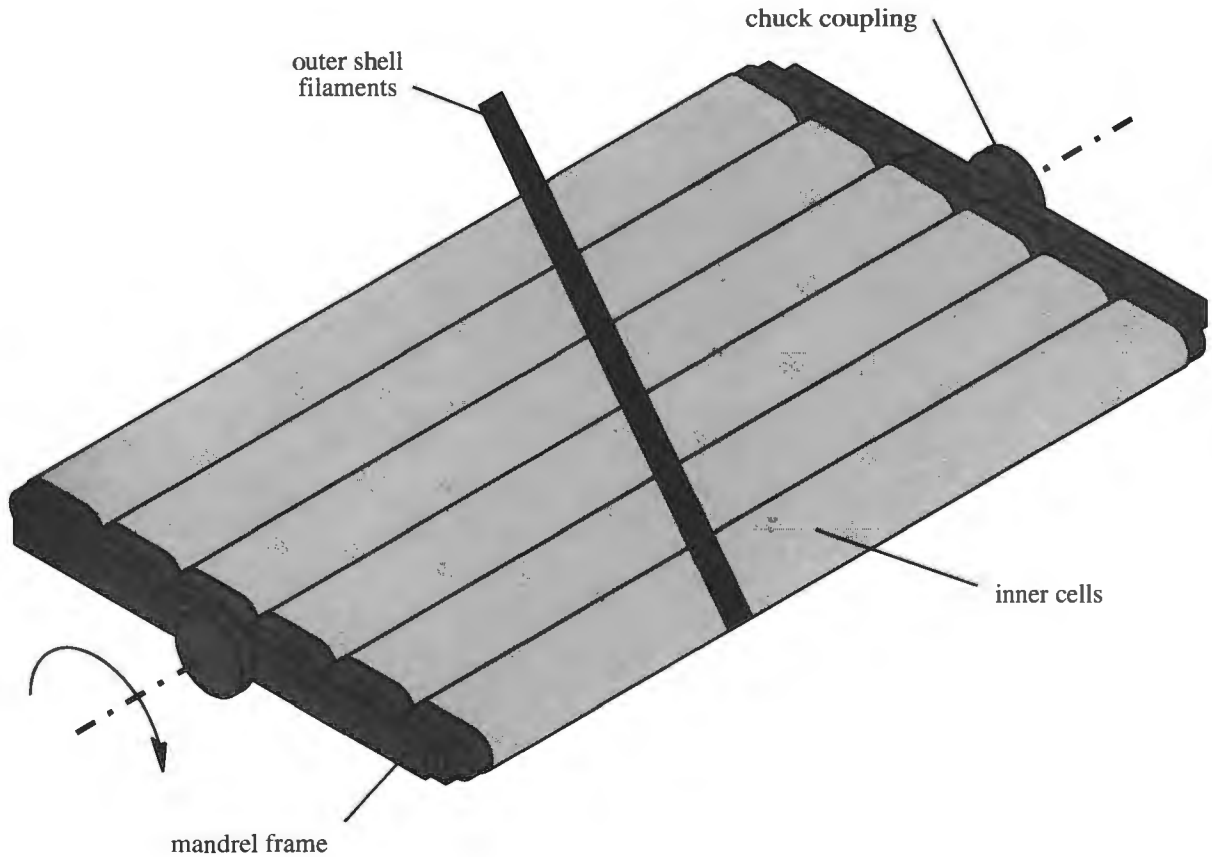

Figure 2

Filament winding of the outer shell onto the inner cells.

The inner cells of the bridge deck will be filament-wound separately. The mandrel will be designed so that it can be extracted after cure. This might necessitate a bi-material mandrel in which the inner core is aluminum and the outer surface is an elastomer. Since the cells are quite long, it could be difficult to extract an aluminum mandrel after cure. In fact, for certain fiber angles it may be impossible to extract such a mandrel after cure because the polymer composite shrinks more than the aluminum during cool down and it effectively clamps down onto the mandrel surface. In this case the use of an elastomer layer provides for sufficient thermal shrinkage and release of the mandrel during cool down. The inner cells can each be wound and cured separately in succession. A total of six are required for each bridge deck prototype system. After manufacturing the inner cells will be trimmed and prepared for integration with the outer shell.

The outer shell structure will also be filament-wound. Here there are two choices for the fabrication procedure. One option is to wind filament directly onto the inner cells. A second option is to attempt to filament wind the outer shell separately and then insert the inner cells after curing of the outer shell. The more direct approach, which will be attempted first, is to wind directly onto the inner cells. The fabrication procedure for winding directly onto the inner cells is detailed in Figure 2. A series of six inner cells will be coupled together with a mandrel

framing system. The frame will be assembled to end pieces that contain a chuck coupling that will fit into the filament winder chucks. Once the inner cell mandrel system is placed into the filament winder, the outer shell filaments will be wound onto the inner cell surfaces.

The primary purpose of the structural tests of the model decks will be to determine the strength and stiffness of the manufactured models when they are subjected to typical bridge deck loads specified by AASHTO. By measuring the deflections and strains at various locations throughout the structure, the predictions of detailed finite element models can also be verified or corrected. This phase will finally produce results that will indicate the performance of a full-sized deck used in an actual bridge.

Product Payoff Potential

Much progress has been made in the integration of advanced composite materials with components of the civil infrastructure. However, additional work is required before practicing structural engineers routinely employ these materials. It is hoped that successful completion of this project will generate sufficient data to prove that the proposed design is structurally sound and can be built economically. These data will form the basis of future funding from industrial sources, culminating in the construction of actual bridge systems.

Product Transfer

A private bridge design and construction company has expressed interest in this project. If early tests are successful, discussions will continue with this and other companies to identify a test site for this structure and the bridge system can be presented as a proof-tested design to state departments of transportation and material manufacturers.

QUANTITATIVE CHARACTERIZATION OF ASPHALT CONCRETES USING HIGH-RESOLUTION X-RAY COMPUTED TOMOGRAPHY (CT)

NCHRP-IDEA Project 64

Richard Ketcham and William Carlson, University of Texas at Austin

IDEA Concept and Product

This project will create the software and analysis tools that are required to utilize industrial high-resolution X-ray computed tomography (CT) to inspect cores of asphalt concrete in order to determine their material characteristics and predict performance. Current methods for design and production of asphalt concrete pavements use indirect measures based on characteristics of the raw materials and the engineering properties of the final product, but cannot incorporate any information about the internal structure of the actual compacted material. The imagery obtainable from industrial CT can be used to construct a complete geometrical model of an asphalt concrete core, allowing location and quantitative description of all aggregates, including their sizes, shapes, and contact points. It can also be used to quantify the extent and distribution of pores, cracks, and other potential zones of weakness. Specific properties to be analyzed in this project include aggregate gradation, orientation, and segregation; statistical description of the spatial distribution of aggregates and voids; and the spatial and angular distribution of aggregate-aggregate contact points. The complete physical representation of asphalt concrete also opens the potential for future application of a wide array of additional analytical tools to help estimate the material properties of pavements, including computer modeling.

Project Results/Planned Investigation

The project has been underway for only two weeks, so it is still at a very early stage. A series of asphalt concrete cores, both experimental and from roadways, have been scanned at the University of Texas High-Resolution X-ray CT Facility to provide test data. The software framework has been laid out, and the first prototype version is expected to be completed within two months. This version will provide basic functionality for simple test cases. After receiving input from our review panel, we will continue development of the software to allow it to handle more complex, real-world situations, and enable it to produce output that will be the most useful for the end-user community.

An individual CT scan produces an image corresponding to a "slice" through a volume. A scan of a complete core consists of a stacked series of slices. In this representation, each pixel in each image becomes a "voxel" (volume element), with a thickness corresponding to the CT slice thickness. The software must classify each voxel in the scan volume as belonging to a certain material, and identify which contiguous (in 3D) voxels can be grouped into individual aggregates. This process can be divided into four basic tasks:

- (1) Segmentation of the CT imagery to identify and distinguish the various components comprising an asphalt core;
- (2) Location of sets of contiguous voxels to identify discrete objects and separation of objects that are touching;
- (3) Extraction of information of interest about the objects, such as location, size, and shape;
- (4) Analysis of the data.

The principal computational difficulty is in accomplishing tasks (1) and (2) reliably. The approach being taken is, in

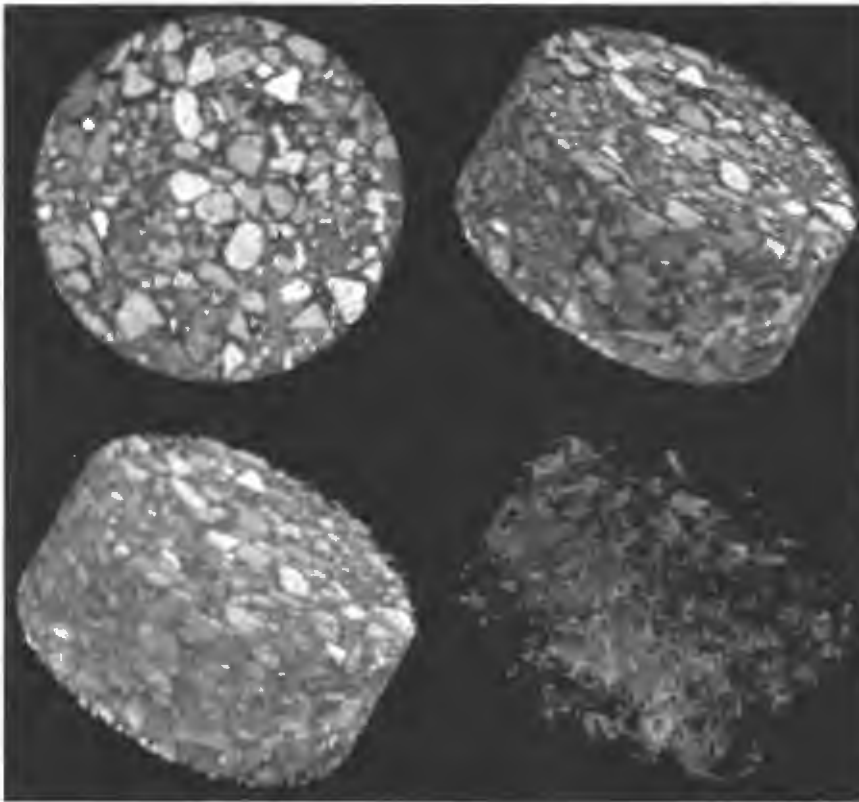

High-resolution industrial X-ray CT is capable of producing detailed 3D imagery of asphalt concrete. The images are from a core 64-mm high and 145-mm in diameter. Top left: single 1 mm-thick CT slice. Top right: complete 3D volume rendering of the entire data set collected for the core. Bottom left: asphalt is rendered transparent, displaying only the aggregates. Bottom right: aggregate and asphalt mastic transparent, showing the connectivity of the void network.

the beginning, to create a powerful graphical interface that will allow an investigator to make key decisions concerning image and volume analysis, or to see, evaluate, and potentially alter computer-made decisions. Future research will increase the level of computer automation in the process, as more knowledge is gathered about the pitfalls and complexities introduced by the variety of aggregate sizes, shapes, and compositions.

Product Payoff Potential

The value of this project will be in its potential to improve the methods by which pavements are formulated and constructed. These techniques can aid in the formulation of mixing methods by comparing experimentally mixed cores; poor-performing mix designs can be identified and eliminated. The analysis enabled here can also be used as a forensic tool to evaluate why a pavement has failed. These investigations should allow creation of higher-quality and longer-lasting pavements, with large indirect savings due to reduced requirements for maintenance and replacement. Five hundred million tons of asphalt concrete is laid down each year as overlays, full-depth pavements, and other applications, at a cost of up to \$15 billion. Any incremental savings enabled by improved pavement design should result in considerable sav-

ings. Reduced vehicle wear due to better pavements would also constitute an indirect but potentially large payoff.

Product Transfer

The software and analytical tools developed will be used by the FIWA in their soon-to-be-acquired industrial CT facility, which will be dedicated to highway research. The software will be usable on any platform (Windows, Macintosh, Unix), and thus will be available to any state highway agency desiring to perform similar research in materials characterization.

SECTION 3 NSF/NRC-IDEA COOPERATIVE PROJECTS

The projects described in this section were conducted using IDEA funds, with cost sharing by the National Science Foundation under a collaborative arrangement between NRC/TRB and the National Science Foundation. The projects were funded in two separate yet interrelated parts. The theoretical investigations and analytical verifications were funded by an NSF grant. IDEA cooperative contracts were utilized to test the product in a practical setting and transfer results to practice.

CONTROL SYSTEM FOR HIGHWAY LOAD EFFECTS

NSF/NCHRP-IDEA Project 1

Andrzej S. Nowak [Tel: (313) 764-8495, Fax: (313) 764-4292],
University of Michigan, Ann Arbor

The project developed and field tested an integrated monitoring system for highway load effects control (Figure 1). The system includes a weigh-in-motion (WIM) truck weight measurement, fatigue load spectra measurement, and failure detection systems. The integrated system coupled with analytical procedures (development of load spectra, component-specific diagnostic test, prediction of remaining fatigue life) was applied for monitoring and providing bridge loading diagnostics. The system proved to be effective on truck parameters (weight, axle loads, speed, lane position, multiple presence) and load effects (girder moments and shears, component-specific strain and stress, fatigue load spectra) for estimating the health and remaining life of the bridge.

The system has the potential to serve as an efficient control measure to monitor highway loads for bridge diagnostics (evaluation of site-specific bridge condition) and management. The results of this project are on the way to implementation by the Michigan Department of Transportation (MDOT). The project team works closely with the technical staff of MDOT. The field work was carried out on bridges selected in coordination with MDOT. Some of the most efficient results that have already been implemented include WIM measurements and proof load testing. The developed procedures have been used by MDOT for evaluation of selected partially deteriorated bridges. The investigators are extending the project to focus on developing a remote-sensing device for measuring lane-specific truck parameters to arrive at practical procedures for active and passive control of truck load effects and to improve prediction of life expectancy and reliability of bridge structures based on WIM measurement.

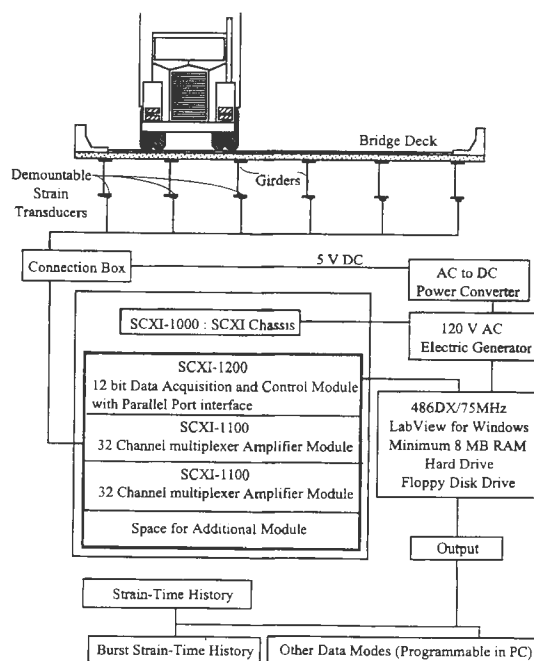

Figure 1
Data acquisition and control system.

PULSE-ECHO TOMOGRAPHIC MICROWAVE IMAGING SYSTEMS FOR QUANTITATIVE NDE OF CIVIL STRUCTURES AND MATERIALS

NSF/NCHRP-IDEA Project 2

Hua Lee [Tel: (805) 893-4480; Fax: (805) 893-3262], University of California, Santa Barbara

The objective of this research is to develop pulse-echo tomographic imaging techniques for quantitative nondestructive evaluation (NDE) of civil structures and materials.

Pulse-echo impulse radar provides a means of detecting voids, cracks, and the condition of concrete reinforcement bars. The ability to recognize and identify the constitution of detected objects is also useful for NDE of civil structures. Classification of the material type permits the confirmation of design specifications and a more accurate evaluation of unknown areas.

Pulse-echo radar transmits a pulse and performs time-delay estimation on the received echoes to form the time-delay profile. A Fourier transform is used to decompose the returns into their frequency components. The frequency components are individually back-propagated to create a wavefield of the area. The wavefields are then superimposed to reconstruct the image area. A singular value decomposition of the wavefield at a target is used to generate a signature vector that minimizes the sum of all distances from each wavefield to its projection onto the vector. Signatures of different materials are stored in a database for comparison to the signatures of unidentified targets. Matches are performed by computing the magnitude of the inner product with each signature in the database. Objects are identified by matching multiple signatures from the target and applying majority rule.

The investigators successfully developed and implemented the image reconstruction algorithm for the data acquisition system and operating configuration. The utilization of wavefield statistics for accurate image formation was optimized and pattern recognition techniques were evaluated. Matching and recognition experiments were performed to demonstrate the application of the technique to evaluate civil structures.

Five classes of materials were used to test the object recognition method. The five targets included an air void, air permeated concrete, a full water occlusion, the air portion of an air/water mix, and the water portion of the air/water mix. All targets were embedded in concrete.

The results showed that the technique identified all targets correctly. In fact, the object recognition scheme was able to correctly identify all classes of test objects with as few as 5 test set vectors.

This experiment demonstrated not only the availability of information content within the frequency passband of the microwave signal for object recognition, but also the excellent accuracy and performance level of the identification techniques for even the most difficult tasks with combined materials.

The technique is being used in industrial applications at the Special Technologies Laboratories of the University of California, Santa Barbara. The California Department of Transportation is

planning to use the technology in conjunction with the Lawrence Livermore National Laboratory system for bridge inspection. Cooperation for implementing the technology will be available from the NSF University/Industry Research Center on High-Speed Image Processing.

APPENDIX

Listing of IDEA Projects Awarded to Date in ITS-IDEA, Transit-IDEA, and High-Speed Rail-IDEA Programs.

ITS-IDEA Projects

- ITS-1: University of Michigan, Ann Arbor, Michigan - "*Collision Avoidance and Improved Traffic Flow Using Vehicle-to-Vehicle Communication*" - (Bernard Galler, Principal Investigator)
- ITS-2: Purdue University, West Lafayette, Indiana - "*Models for Real-Time Incident Prediction*" - (S. Madanat, Principal Investigator)
- ITS-3: CF International, Reno, Nevada - "*Improved Metropolitan Area Transportation Systems (IMATS): Carpooling and Computerized Vehicle Dispatching in Association with a Vehicle Rental System*" - (John Chisholm, Principal Investigator)
- ITS-4: Louisiana State University, Baton Rouge, Louisiana - "*A Distributed Input/Output Subsystem for Traffic Signal Control*" - (Darcy Bullock, Principal Investigator)
- ITS-5: Auburn University, Auburn, Alabama - "*Feasibility Study of IVHS Drifting Out of Lane Alert System*" - (Ed Ramey, Principal Investigator)
- ITS-6: Schwartz Electro-Optics, Inc., Orlando, Florida - "*Laser-Based Vehicle Detector/Classifier*" - (Richard Wangler, Principal Investigator)
- ITS-7: Honeywell Technology Center, Minneapolis, Minnesota - "*Driver-Adaptive Warning System*" - (Chris Miller, Principal Investigator)
- ITS-8: SUNY at Stony Brook, Stony Brook, New York - "*Laser Optics Open-Air Communication System*" - (Sheldon Chang, Principal Investigator)
- ITS-9: University of Michigan, Ann Arbor, Michigan - "*Decision-Theoretic Reasoning for Traffic Monitoring and Vehicle Control*" - (Michael Wellman, Principal Investigator)
- ITS-11: SRI International, Menlo Park, California - "*Scale-Model AHS Research Facility (SMARF)*" - (Raul Vera, Principal Investigator)
- ITS-12: Compuline, Inc., La Jolla, California - "*Vehicle Lane Control System*" - (Bill Bush, Principal Investigator)
- ITS-13: University of Washington, Seattle, Washington - "*Development of an Intelligent Air Brake Warning System for Commercial Vehicles*" - (Per Reinhall, Principal Investigator)
- ITS-14: Christian Brothers University, Memphis, Tennessee - "*Adaptive Filtering for ITS and Advanced Vehicle Control*" - (Laura Ray, Principal Investigator)
- ITS-15: Purdue University, West Lafayette, Indiana - "*Efficient Use of Narrowband Radio Channels for Mobile Digital Communications*" - (Michael Fitz, Principal Investigator)
- ITS-16: University of California, Berkeley, California - "*Engineered Visibility Warning Signals: Tests of Time to React, Detectability, Identifiability and Salience*" - (Ed Cohn, Principal Investigator)
- ITS-17: Purdue University, West Lafayette, Indiana - "*Sequential Hypothesis Testing-Based Decision-Making System for Freeway Incident Response*" - (S. Madanat, Principal Investigator)
- ITS-18: Northrop-Grumman Corp., Pico Rivera, California - "*Three-in-One Vehicle Operator Sensor*" - (Rick Hamlin, Principal Investigator)
- ITS-19: The Analytic Sciences Corp. (TASC), Reading, Massachusetts - "*AutoAlert: Automated Acoustic Detection of Traffic Incidents*" - (Dave Whitney, Principal Investigator)

- ITS-20: National-Louis University, Oak Park, Illinois - "*Real Time, Computer-Matched Ridesharing Using Cellular or Personal Communications Services (RTCMR/PCS)*" - (Ed Walbridge, Principal Investigator)
- ITS-21: Northrop-Grumman Corp., Rolling Meadows, Illinois - "*Interference-Resistant Signals for Collision Avoidance Radar*" - (Mark Hischke, Principal Investigator)
- ITS-23: Johns Hopkins University, Laurel, Maryland - "*GPS Drain: Demonstration of Precise Navigation for Vehicle Collision Avoidance*" - (Mark Asher, Principal Investigator)
- ITS-24: Swales and Associates, Inc., Huntsville, Alabama - "*Passive Optical Lane Position Monitor*" - (Joseph Geary, Principal Investigator)
- ITS-25: Eaton Corp., Southfield, Michigan - "*Automated Roadside Brake Inspection Concept Evaluation*" - (Thomas Wissing, Principal Investigator)
- ITS-26: University of Delaware, Newark, Delaware - "*Fuzzy Inference Based Driver Decision Process and Traffic Flow Simulator*" - (Sinya Kikuchi, Principal Investigator)
- ITS-27: University of Illinois at Chicago, Chicago, Illinois - "*Application of Neural Networks to Data Fusion: A Feasibility Study*" - (Peter Nelson, Principal Investigator)
- ITS-28: University of Michigan, Ann Arbor, Michigan - "*Development and Evaluation of Communication Requirements for Low-Cost Network-Based Driving Sensors for ITS Safety Research*" - (Paul Green, Principal Investigator)
- ITS-29: Waveband Corp., Torrance, California - "*Innovative Scanning Antenna Systems for Advanced Recognition of Rail Collision, Obstacle Detection, and Automobile Collision Avoidance*" - (Lev Sadovnik, Principal Investigator)
- ITS-30: Intelligent Highway Systems, Inc., White Plains, New York - "*Vehicle Detection and Tracking from a Wide Angle Sensor's Video Signal for Intersection Control and Intelligence*" - (Eugene Waldenmaier, Principal Investigator)
- ITS-32: Northrop-Grumman Corp., Rolling Meadows, Illinois - "*National Coverage for Emergency Mayday Systems*" - (Dave Richardson, Principal Investigator)
- ITS-33: Ohio State University, Columbus, Ohio - "*Radar-Based Convoying Using a Frequency Selective Surface Patch for Trucks, Railroads, and AHS*" - (Umit Ozguner, Principal Investigator)
- ITS-34: Nichols Research Corp., Arlington, Virginia - "*Remote Passive Road Ice Sensor System (RPRISS)*" - (Jack Reed, Principal Investigator)
- ITS-35: DVP, Inc., Rockville, Maryland - "*An Expert System-Based Diagnostic Instrument for IVHS Maintenance Operations*" - (Boris Donskoy, Principal Investigator)
- ITS-36: University of Michigan, Ann Arbor, Michigan - "*Application of Decision Analysis to ITS Societal Issues*" - (Barbara C. Richardson, Principal Investigator)
- ITS-38: Fiber and Sensor Technologies, Inc., Blacksburg, Virginia - "*Fiber Optic Visibility Sensor System*" - (Richard O. Claus, Principal Investigator)
- ITS-40: Oregon State University, Corvallis, Oregon - "*Application of Ergonomic Guidelines for APTS Technology to Practice*" - (Katharine Hunter-Zaworski, Principal Investigator)
- ITS-41: QST Electronics, Inc., La Jolla, California - "*Resonant Loop Lane Control*" - (E. William Bush, Principal Investigator)
- ITS-42: Quantics, San Diego, California - "*Anti-Glare Device Using Photochromic Focal Plane*" - (George S. Levy, Principal Investigator)
- ITS-43: Weissman Science & Engineering Co., Washington, D.C. - "*Feasibility Study for a Regional Traffic Surveillance Concept*" - (Isaac Weissman, Principal Investigator)
- ITS-44: National Institute of Statistical Sciences, Raleigh, North Carolina - "*Integration of Empirical Models of Vehicle Emissions Within Advanced Traffic Management Systems*" - (Nagui Roupail, Principal Investigator)

- ITS-45: University of Utah, Salt Lake City, Utah - *“Automated Roadway Avalanche Hazard Reduction: An Intelligent Transportation System for Rural Winter Transit”* - (Rand Decker, Principal Investigator)
- ITS-47: Purdue University, West Lafayette, Indiana - *“A Spectrally Efficient Wireless Modem for ITS Applications”* - (Michael P. Fitz, Principal Investigator)
- ITS-48: CF International, Reno, Nevada - *“Instant Rent-A-Car Technology Applied to Transit Station Car Practice”* - (John Chisholm, Principal Investigator)
- ITS-49: Purdue University, West Lafayette, Indiana - *“Travel Time Prediction in Intelligent Transportation Systems”* - (Andrzej P. Tarko, Principal Investigator)
- ITS-50: Physical Sciences, Inc., Andover, Massachusetts - *“Road Surface Condition Detection and Monitoring Technology for a Vehicle-Mounted Hazard Warning System”* - (Prakash Joshi, Principal Investigator)
- ITS-51: Pennsylvania State University, University Park, Pennsylvania - *“Development of Risk Factor Reduction Guidelines to Facilitate Participation, Deployment, and Operations in ITS”* - (John Bagby, Principal Investigator)
- ITS-52: DVP, Inc., Rockville, Maryland - *“An Advanced Diagnostic Instrument for Inductive Loop System Maintenance”* - (Boris Donskoy, Principal Investigator)
- ITS-53: University of Utah, Salt Lake City, Utah - *“A Real-Time Flow Estimation Model for Advanced Urban Traffic Control”* - (Peter Martin, Principal Investigator)
- ITS-56: ERIM, Ann Arbor, Michigan - *“Snow and Ice Removal Monitoring and Management System Project”* - (Paul K. Zoratti, Principal Investigator)
- ITS-57: University of Michigan, Ann Arbor, Michigan - *“Differential Braking for Limited-Authority Lateral Maneuvering to Support Active Safety Systems”* - (Robert Ervin, Principal Investigator)
- ITS-60: Sensor Technologies & Systems Inc., Scottsdale, Arizona - *“Visibility Monitoring System”* - (Terry Wilson, Principal Investigator)
- ITS-61: University of California, Los Angeles, California - *“IRIS: Intelligent Ranging with Infrared Sensors”* - (Ioannis Kanellakopoulos, Principal Investigator)
- ITS-62: University of Massachusetts, Dartmouth, Massachusetts - *“Wavelet-Based Image Compression and Analysis System for ITS”* - (C.H. Chen, Principal Investigator)
- ITS-63: Midland Associates, Inc., Minneapolis, Minnesota - *“Electronic Safety System for Emergency Vehicles”* - (Douglas Maxwell, Principal Investigator)
- ITS-65: Schwartz Electro-Optics, Inc., Orlando, Florida - *“Improved Vehicle Classification Using an Overhead Imaging Lidar System with Axle Counting Capability”* - (Robert Gustavson, Principal Investigator)
- ITS-66: Multispectral Solutions, Inc., Gaithersburg, Maryland - *“Use of Ultra Wideband (UWB) Technology for Designated Short Range Communications (DSRC)”* - (Robert Fontana, Principal Investigator)
- ITS-69: KLD Associates, Inc., Huntington Station, New York - *“Real-Time Traffic Control of Over-Saturated Conditions”* - (Edward Lieberman, Principal Investigator)
- ITS-71: Kaman Sciences Corp., Colorado Springs, Colorado - *“Real-Time Signal Control Using Queue Length Information Deployed at an Intersection”* - (Robert Larson, Principal Investigator)
- ITS-72: University of California, Irvine - *“Algorithms for Carrier Fleet Operations Demand Responsive Services for Standard Ground and Intermodal Freight Movements”* - (Amelia C. Regan, Principal Investigator)
- ITS-73: The Centre for Education and Research in Safety, Cambridge, Massachusetts - *“Animated LED ‘Eyes’ Traffic Signals”* - (Ron Van Houten, Principal Investigator)

- ITS-74: Lexington Consulting, Cambridge, Massachusetts - *"Data Communications for Remote Sensors Using ReFLEX Narrowband PCS Technology"* - (Sudhir Murthy, Principal Investigator)
- ITS-75: University of Washington - *"Data Communications for Remote Sensors Using ReFLEX Narrowband PCS Technology"* - (Per Reinhall, Principal Investigator)
- ITS-76: University of California at Berkeley - *Inexpensive Inertial Navigation System with GPS-Based Attitude Determination* (Principal Investigator: Pravin Varaiya)
- ITS-77: Sri International, Menlo Park, California - *Inexpensive Inertial Navigation System (Ins) With Gps-Based Attitude Determination* (Principal Investigator: Randy Galijan, Other participants: University of California at Berkeley)
- ITS-78: Utah State University, Logan - *Simulation Model For Evaluating Traffic Management Strategies On Intermodal Passenger Terminal Access Roadway Systems* (Principal Investigator: Prianka Seneviratne)
- ITS-79: Weather Solutions Group, Chesterfield, Missouri - *Roadway Flash Flood Warning Devices – Feasibility Study* (Principal Investigator: Edward Boselly)
- ITS-80: Minnesota Department of Transportation, St. Paul - *Snowplow Operator Assist System* (Principal Investigators: Marthand Nookala and Stephen Bahler, Other Participants: University of Minnesota, 3M, Altra Technologies, Booz-Allen and Hamilton)
- ITS-82: University of Colorado at Denver - *Modeling Bicycles in Traffic for Advanced Traffic Management and Control* (Principal Investigator: Sarosh Khan)
- ITS-83: Connecticut Analytical Corporation, Bethany - *Deceleration Warning System for Commercial Vehicles* (Principal Investigator: Joseph Bango, Jr.)
- ITS-84: I-Witness Inc., San Diego, California - *I-Witness Black Box Recorder*, (Principal Investigators: Gary Rayner and Sophia Rayner)
- ITS-85: Physical Sciences Inc., Andover, Massachusetts - *A Mobile Road Condition Sensor as Winter Maintenance Aid* (Principal Investigator: Prakash Joshi)
- ITS-86: *A 220MHz Modem for ITS: The Final Step to Deployment* (Principal Investigators: Bjorn Bjerede, Welkin Systems Inc., San Diego, California and Michael Fitz, Ohio State University, Columbus)

Transit-IDEA Projects

- Transit-1: Tri-County Metropolitan Transportation District of Oregon, Portland, Oregon - *"Customer Satisfaction Index for the Mass Transit Industry"* - (Kathryn Coffel, Principal Investigator)
- Transit-2: Bay Area Rapid Transit District, Oakland, California - *"Adaptive Diagnostic System Project"* - (Steven Mullerheim, Principal Investigator)
- Transit-3: International Electronic Machines Corp., Albany, New York - *"Automatic Wheel Inspection Station"* - (Zahid Mian, Principal Investigator)
- Transit-4: Northeastern University, Boston, Massachusetts - *"Management Information Benefits of On-Board Integration of Electronic Fareboxes"* - (Peter Furth, Principal Investigator)
- Transit-5: Greneker and Associates, Inc., Marietta, Georgia - *"Improved Passenger Counter and Classification System for Transit Applications"* - (E. F. Greneker, Principal Investigator)
- Transit-7: Baylor College of Medicine, Houston, Texas - *"Wheelchair Restraint System"* - (Thomas Krouskop, Principal Investigator)
- Transit-8: Transcom International Ltd., Winnipeg, Manitoba, Canada - *"Real-Time Transit Data Broadcast"* - (Edward Burgener, Principal Investigator)

- Transit-9: Southern Maine Areas Agency on Aging, Portland, Maine - *"The Independent Transportation Network: Alternative Transportation for the Elderly"* - (Katherine Freund, Principal Investigator)
- Transit-10: Advanced Systems Group International, Herndon, Virginia - *"Automatic Data Collection on Transit Users via Radio Frequency Identification"* - (Stephen Briggs, Principal Investigator)
- Transit-11: San Francisco Municipal Railway, San Francisco, California - *"Compact Disc, Interactive Violence Prevention Training Program"* - (Debi Horen, Principal Investigator)
- Transit-12: Vertical Systems, Inc., Bellevue, Washington - *"Transit and Intermodal Scheduling Using Expert Systems"* - (David Muchmore, Principal Investigator)
- Transit-13: TransTech Management, Wayland, Massachusetts - *"Interactive PC-Based Track Safety Training"* - (Daniel Mesnick, Principal Investigator)
- Transit-14: CF International, Reno, Nevada - *"Instant Rent-A-Car Technology Applied to Transit Station Car Practice"* - (John Chisholm, Principal Investigator)
- Transit-15: Kiernan Transit Associates, Lafayette, California - *"Internet Information Sharing for Transit Maintenance (TranspoNet)"* - (Victor D. Kiernan, Principal Investigator)
- Transit-16: The Cleveland Clinic Foundation, Cleveland, Ohio - *"Transit Restraint System for Wheel Chairs"* - (Steven Roger, Principal Investigator)
- Transit-17: International Electronic Machines Corp., Albany, New York - *"Operational Evaluation of Rail Based Wheel Gauge Inspection System"* - (Zahid Mian, Principal Investigator)
- Transit-18: Independent Transportation Network, Portland, Maine - *"Pilot Testing Innovative Payment Operations for Independent Transportation for the Elderly"* - (Katherine Freund, Principal Investigator)
- Transit-19: University of Virginia, Charlottesville, Virginia - *"Field Testing and Evaluation of the Transit Integrated Monitoring System"* - (Manuel D. Rossetti, Principal Investigator)
- Transit-20: Greneker and Associates, Inc., Marietta, Georgia - *"Non-Contact Sensor for Passenger Counting and Classification"* - (Gene Greneker, Principal Investigator)
- Transit-21: Oregon State University, Corvallis, Oregon - *"Smart Parking Lot with Just-in-Time Bus Service"* - (Chris A. Bell, Principal Investigator)
- Transit-22: Arthur D. Little, Inc., Cambridge, Massachusetts - *"Sleeved Column System for Crash Worthiness of Light Rail Vehicles"* - (Ronald Mayville, Principal Investigator)
- Transit-23: Washington University, St. Louis, Missouri - *"Optimizing Travel Path for People with Disabilities"* - (W. Davis van Bakergem, Principal Investigator)
- Transit-24: Tranergy Corporation, Bensenville, Illinois - *"Operational Testing of Innovative and Intelligent Rail Lubrication System"* - (Sudhir Kumar, Principal Investigator)
- T-25: SYSTAN, Inc. - *Operating Policies for Improved Transit Productivity* (Principal Investigator: Roy Lave)
- T-26: Ultimate Technologies - *Designing Transit Services for the Mode-Choice Market, Stage III: Planning Tools and Processes* (Principal Investigator: Alan Hoffman)
- T-27: Columbia University - *Gap Guard* (Principal Investigator: Richard J. Muller)

HSR-IDEA Projects

- HSR-1: Waveband Corp., Torrance, California - *"Innovative Scanning Antenna Systems for Advanced Recognition of Rail Collision, Obstacle Detection, and Automobile Collision Avoidance"* - (Lev Sadovnik, Principal Investigator)

- IISR-2: Intelligent Highway Systems, White Plains, New York - "*Vehicle Detection and Tracking from a Wide Angle Sensor's Video Signal for Intersection Control and Intelligence*" - (Eugene Waldenmaier, Principal Investigator)
- HSR-3: SUNY at Stony Brook, Stony Brook, New York - "*Assessment of Laser Optics Open-Air Communication System for Railroads and Highways*" - (Sheldon Chang, Principal Investigator)
- HSR-5: Pulse Electronics, Inc., Rockville, Maryland - "*Enhanced Proximity Warning System*" - (Robert C. Kull, Principal Investigator)
- HSR-6: Intelligent Highway Systems, White Plains, New York - "*Demonstration and Testing of IHS Wide Field Surveillance System Integration with the Highway and Railway Infrastructure*" - (Eugene Waldenmaier, Principal Investigator)
- HSR-7: Relume Corp., Troy, Michigan - "*Pulsed LED Railroad Crossing Signals*" - (Peter A. Hochstein, Principal Investigator)
- HSR-8: O'Conner Engineering, Inc., Benicia, California - "*Remote Sensing Advance Warning Systems Test Project*" - (Joe O'Conner, Principal Investigator)
- HSR-9: Foster-Miller, Inc., Waltham, Massachusetts - "*Single Arm Folding Extension*" - (Peter Warren, Principal Investigator)
- HSR-10: Nestor, Inc., Providence, Rhode Island - "*A Neural Network Video Sensor Application for Rail Crossing Safety*" - (Douglas Reilly, Principal Investigator)
- HSR-11: Rail Safety Engineering, Inc., Rochester, New York - "*Quad Gate Crossing System*" - (David Rutherford, Principal Investigator)
- HSR-12: Aspen Systems, Inc., Marlborough, Massachusetts - "*Fiberoptic Relayed Laser Radar for Railroad Transportation*" - (Kannan Krishnaswami, Principal Investigator)
- HSR-13: Waveband Corp., Torrance, California - "*Development of a Highway-Railroad Grade-Crossing Obstacle Detection Radar*" - (Vladimir Manasson, Principal Investigator)
- HSR-14: ENSCO, Inc. - "*Low-Cost Multiple Inertial Measurement for Locomotive Navigation*" (Principal Investigator: Fred Riewe)
- HSR-15: University of Utah - "*Development of a Hybrid Uni-Axial Strain Transducer to Periodically Monitor Transportation Infrastructure*" (Principal Investigator: Hosin Lee)
- HSR-16: Texas Transportation Institute - "*Advanced Train Detection for Preemption of Highway Traffic Controllers*" (Principal Investigator: Steven Venglar)
- HSR-17: Raven, Inc. - "*Automatic Flagging System for Track Maintenance Workers*" (Principal Investigator: James Genova)
- HSR-18: Texas Transportation Institute - "*An Investigation into the Use of Buried Fiber Optic Filament to Detect Trains and Broken Rail*" (Principal Investigator: Stephen Roop)
- HSR-19: University of Illinois - "*Fiber Optic Sensors for High-Speed Rail Applications*" (Principal Investigator: S.L. Chuang)
- IISR-20: Fraunhofer Resource Center - "*Metal Foams for Safety Improvement*" (Principal Investigator: Harald Eifert)

The Transportation Research Board is a unit of the National Research Council, a private, nonprofit institution that provides independent advice on scientific and technical issues under a congressional charter and the operating arm of the National Academies.

The mission of the Transportation Research Board is to promote innovation and progress in transportation by stimulating and conducting research, facilitating the dissemination of information, and encouraging the implementation of research findings. The Board's varied activities annually draw on approximately 4,000 engineers, scientists, and other transportation researchers and practitioners from the public and private sectors and academia, all of whom contribute their expertise in the public interest. The program is supported by state transportation departments, federal agencies including the component administrations of the U.S. Department of Transportation, and other organizations and individuals interested in the development of transportation.

The National Academies are a nonprofit, self-perpetuating society of distinguished scholars engaged in scientific and engineering research, dedicated to the furtherance of science and technology and to their use for the general welfare. Upon the authority of the charter granted to it by Congress in 1863, the National Academies have a mandate that requires them to advise the federal government on scientific and technical matters.

TRANSPORTATION RESEARCH BOARD
NATIONAL RESEARCH COUNCIL

NATIONAL ACADEMY PRESS
Washington, DC 1999

TRANSPORTATION RESEARCH BOARD

Research Council

Constitution Avenue, N.W.

Washington, D.C. 20418

CORRECTION REQUESTED

MTA DOROTHY GRAY LIBRARY & ARCHIVE



ED6LTC0000001

NON-PROFIT ORG.
U.S. POSTAGE
PAID
WASHINGTON, D.C.
PERMIT NO. 8970

*****MIXED ADC 206
007168-00
KEITH L KILLOUGH
LOS ANGELES COUNTY MTA
MS 99-23-7
ONE GATEWAY PLAZA
LOS ANGELES CA 90012-2932