



IDEA

**Innovations Deserving
Exploratory Analysis Programs**

NCHRP HIGHWAY

**New IDEAS
for Highway Systems**

Annual Progress Report

JANUARY 2001

TRANSPORTATION RESEARCH BOARD • NATIONAL RESEARCH COUNCIL

TRANSPORTATION RESEARCH BOARD EXECUTIVE COMMITTEE 2001

OFFICERS

CHAIR: **Martin Wachs**, Director, Institute of Transportation Studies, University of California at Berkeley

VICE CHAIR: **John M. Samuels**, Senior Vice President-Operations Planning & Support, Norfolk Southern Corporation, Norfolk, VA

EXECUTIVE DIRECTOR: **Robert E. Skinner, Jr.**, Transportation Research Board

MEMBERS

THOMAS F. BARRY, JR., Secretary of Transportation, Florida DOT

JACK E. BUFFINGTON, Associate Director and Research Professor, Mack-Blackwell National Rural Transportation Study Center, University of Arkansas

SARAH C. CAMPBELL, President, TransManagement, Inc., Washington, DC

ANNE P. CANBY, Secretary of Transportation, Delaware DOT

E. DEAN CARLSON, Secretary of Transportation, Kansas DOT

JOANNE F. CASEY, President, Intermodal Association of North America

JOHN L. CRAIG, Director, Nebraska Department of Roads

ROBERT A. FROSCHE, Senior Research Fellow, John F. Kennedy School of Government, Harvard University

GORMAN GILBERT, Director, Institute for Transportation Research and Education, North Carolina State University

GENEVIEVE GIULIANO, Professor, School of Policy, Planning, and Development, University of Southern California, Los Angeles

LESTER A. HOEL, L.A. Lacy Distinguished Professor, Department of Civil Engineering, University of Virginia

H. THOMAS KORNEGAY, Executive Director, Port of Houston Authority

THOMAS F. LARWIN, General Manager, San Diego Metropolitan Transit Development Board

BRADLEY L. MALLORY, Secretary of Transportation, Pennsylvania DOT

JEFFREY R. MORELAND, Senior Vice President-Law and Chief of Staff, Burlington Northern Santa Fe Corporation, Fort Worth, TX

SIO MORRISON, Secretary of Transportation, Washington State DOT

JOHN P. POORMAN, Staff Director, Capital District Transportation Committee, Albany, NY

WAYNE SHACKELFORD, Senior Vice President, Gresham Smith & Partners, Alpharetta, GA

MICHAEL S. TOWNES, Executive Director, Transportation District Commission of Hampton Roads, Hampton, VA

THOMAS R. WARNE, Executive Director, Utah DOT

ARNOLD F. WELLMAN, JR., Vice President, Corporate Public Affairs,

United Parcel Service, Washington, DC

JAMES A. WILDING, President and CEO, Metropolitan Washington Airports Authority

M. GORDON WOLMAN, Professor of Geography and Environmental Engineering, The Johns Hopkins University

DAVID N. WORMLEY, Dean of Engineering, Pennsylvania State University

MIKE ACOTT, President, National Asphalt Pavement Association (ex officio)

SUE BAILEY, National Highway Traffic Safety Administrator, U.S.DOT (ex officio)

KELLEY S. COYNER, Research and Special Programs Administrator, U.S.DOT (ex officio)

MORTIMER L. DOWNEY, Deputy Secretary of Transportation, U.S.DOT (ex officio)

NURIA I. FERNANDEZ, Acting Administrator, Federal Transit Administration, U.S.DOT (ex officio)

RUSSELL L. FUHRMAN (Maj. Gen., U.S. Army), Acting Commander, U.S. Army Corps of Engineers (ex officio)

JANE F. GARVEY, Federal Aviation Administrator, U.S.DOT (ex officio)

EDWARD R. HAMBERGER, President and CEO, Association of American Railroads (ex officio)

CLYDE J. HART, JR., Administrator, Maritime Administration, and Acting Deputy Administrator, Federal Motor Carrier Safety Administration, U.S.DOT (ex officio)

JOHN C. HORSLEY, Executive Director, American Association of State Highway and Transportation Officials (ex officio)

JAMES M. LOY (Adm., U.S. Coast Guard), Commandant, U.S. Coast Guard (ex officio)

WILLIAM W. MILLAR, President, American Public Transportation Association (ex officio)

JOLENE M. MOLITORIS, Federal Railroad Administrator, U.S.DOT (ex officio)

MARGO DGE, Director, Office of Transportation and Air Quality, U.S. Environmental Protection Agency (ex officio)

VALENTIN J. RIVA, President and CEO, American Concrete Pavement Association (ex officio)

ASHISH K. SEN, Director, Bureau of Transportation Statistics, U.S.DOT (ex officio)

KENNETH R. WYKLE, Federal Highway Administrator, U.S.DOT (ex officio)

Publications of the IDEA Programs are available on the internet at national-academies.org/trb/IDEA.

Further information is available by contacting the IDEA Program Office by phone (202-334-3310) or fax (202-334-3471).

Transportation Research Board publications may be ordered directly from the TRB Business Office, through the internet at national-academies.org/trb, or by annual subscription through organization or individual affiliation with TRB. Affiliates and library subscribers are eligible for substantial discounts.

For further information contact the Transportation Research Board Business Office, National Research Council

2101 Constitution Avenue, NW, Washington, DC 20418. (telephone 202-334-3214; fax 202-334-2519; or email TRBsales@nas.edu).

43a56153

**NEW IDEAS FOR
HIGHWAY SYSTEMS**

**An Annual Progress Report of the
NCHRP IDEA Program**

2001

Transportation Research Board

National Research Council

MTA LIBRARY

NCHRP-IDEA PROGRAM COMMITTEE

Earl C. Shirley, Chairman
Consulting Engineer, California

Charles Arnold
Consulting Engineer, Michigan

Sidney Green
Terra Tek

Robert Gubala
Consulting Engineer, Connecticut

Susan Martinovich
Nevada Department of Transportation

Carol Murray
New Hampshire Department of Transportation

Arunprakash Shirole
Consulting Engineer, Minnesota

Lawrence Smith
Consulting Engineer, Florida

Richard Stewart
South Carolina Department of Transportation

James Taylor
University of Notre Dame

Paul Teng
Federal Highway Administration

Jon Underwood
Consulting Engineer, Texas

NCHRP-IDEA Program
Inam Jawed, *Manager*

NCHRP Program
Crawford Jencks, *Manager*

DOT/FHWA Research Programs
Roy Trent, *Federal Highway Administration*

TRB Divisions
Robert E. Skinner, Jr., *Executive Director*
Robert J. Reilly, *Director, Cooperative Research
Programs*

Neil F. Hawks, *Director, Special Programs*
Mark R. Norman, *Director, Technical Activities*
Stephen R. Godwin, *Director, Studies and
Information Services*

Marcia A. Appel, *Director, Administration and
Finance*

INTRODUCTION

This annual report presents a summary of progress on investigations conducted as part of the Innovations Deserving Exploratory Analysis (IDEA) program for the National Cooperative Highway Research Program (NCHRP). The NCHRP-IDEA program is jointly funded by the Federal Highway Administration and state transportation agencies in cooperation with the American Association of State Highway and Transportation Officials.

NCHRP-IDEA is one of four IDEA programs managed by the Transportation Research Board (TRB) to foster innovation in highway and intermodal surface transportation systems. NCHRP-IDEA nurtures new concepts for technologies, methods, and processes for application to highway systems in broad technical areas such as highway design and construction, materials, operations, and maintenance. The other IDEA programs are

- Transit-IDEA, which focuses on products and results for transit practice in support of the Transit Cooperative Research Program;
- ITS-IDEA, which focuses on products and results for the development and deployment of intelligent transportation systems in support of the U.S. Department of Transportation's national ITS program; and
- High-Speed Rail-IDEA, which focuses on advanced technologies for high-speed rail operations in support of the Federal Railroad Administration's Next Generation High-Speed Rail Program.

All four IDEA programs are integrated to support advances in highway, transit, ITS, rail, and intermodal systems.

The IDEA programs are open to all individuals, including entrepreneurs, small and large businesses, and institutions. The programs provide an opportunity to investigate new and unproven concepts or to evaluate other novel applications of technologies that have been tried, tested, or used for highway, transit, high-speed rail, or intermodal systems practice.

The selection of each IDEA investigation is made by consensus recommendations from panels of national experts in highway and transportation research and practice and is approved by the NCHRP-IDEA Project Committee, whose members are listed at the beginning of this report. A technical expert is selected from outside TRB to serve as a voluntary advisor to mentor each IDEA project. The technical project advisor provides continuing advice and counsel on the IDEA investigation to the investigator and the IDEA program office. In order to begin the product transfer process from the initiation of each IDEA project, a regional panel of experts is nominated to work with the investigator on product development and transfer to highway practice. The products emerging from the NCHRP-IDEA project support a range of innovative developments for highway user services and for advancing highway systems.

Section 1 of this report presents short descriptions of projects completed before the 2000 program year. The products and results from these projects have been applied or are available for further investigation for application to highway practice. The product status is described under each project. Because of limitations on IDEA resources, not all IDEA concepts that prove feasible can be accommodated for follow-up funding by the NCHRP-IDEA program for product transfer. Section 2 presents reports of investigations on projects active or completed during the 2000 program year; several projects in this section are in the initial stages of

27800

JUN 08 2001

investigation. Section 3 presents IDEA projects performed under a cost-sharing initiative with the National Science Foundation.

In selecting new concepts, the IDEA program balances the quest for new products with an understanding of the barriers each product may face for application to practice. Assessing the level of readiness for deployment of IDEA products and results is important in deciding on follow-up actions that are necessary to transfer the IDEA product to practice. The annual report is intended to provide highway practitioners with the background on each IDEA investigation and product in development so that a dialogue on its potential transfer can take place between the investigator and highway practitioners.

The IDEA program welcomes your comments, suggestions, or recommendations on NCHRP-IDEA projects, products, and results presented in this report. Please forward them to The NCHRP-IDEA Program (attention: Dr. Inam Jawed), Transportation Research Board, 2101 Constitution Avenue, NW, Washington, DC 20418; fax: 202-334-3471; e-mail: ijawed@nas.edu.

TE

1

.A3

N35

2001

TABLE OF CONTENTS

SECTION 1: Completed IDEA Projects

Project	Page
1 <i>On-Line Real-Time Measurement and Control of Aggregate Gradation in Asphalt Plants</i> Felix ALBA Consultants Inc., Murray, Utah STAKER Paving and Construction Company, Salt Lake City, Utah	2
2 <i>A Method for Measuring Water-Stripping Resistance of Asphalt/Siliceous Aggregate Mixtures</i> National Institute of Standards and Technology, Gaithersburg, Maryland	3
3 <i>Guidelines for Low-Cost Sprayed-Zinc Galvanic Anode for Controlling Corrosion of Reinforcing Steel in Marine Bridge Substructures</i> University of South Florida Florida Department of Transportation, Gainesville, Florida	4
4 <i>Exploring the Feasibility of Replacing Latex with Asphalt Emulsion for Use in Bridge Deck Overlays</i> Purdue University, West Lafayette, Indiana	5
5 <i>Magnetic Resonance for In Situ Determination of Asphalt Aging and Moisture Content</i> Southwest Research Institute, San Antonio, Texas	6
6 <i>Excogitated Composite Multifunctional Layer for Pavement Systems</i> University of Illinois, Urbana-Champaign, Illinois	7
7 <i>Strategy for Coating Structural Steel Without Stringent Blasting Regulations</i> Steel Structures Painting Council, Pittsburgh, Pennsylvania	8
8 <i>Conservation Traffic Control Load Switch</i> CLS Incorporated, Westerville, Ohio	9
9 <i>Corrosion-Resistant Steel Reinforcing Bars</i> University of Kansas, Lawrence, Kansas	10
10 <i>Metallic Coating for Corrosion Protection of Steel Rebars</i> SRI International, Menlo Park, California	11
11 <i>Rehabilitation of Steel Bridges Through the Application of Advanced Composite Materials</i> University of Delaware, Newark, Delaware	12
12 <i>Advanced Testing of an Automatic Nondestructive Evaluation System for Highway Pavement Surface Condition Assessment</i> Illinois Institute of Technology, Chicago, Illinois	13
13 <i>New Additive for Improved Durability of Concrete</i> University of Connecticut, Storrs, Connecticut Todd Chemical Company, Cheshire, Connecticut	14

Project	Page
14 <i>Unreinforced, Centrally Prestressed Concrete Columns and Piles</i> Florida Atlantic University, Boca Raton, Florida	15
15 <i>Portable Laser Road Crew Warning System</i> Lockheed Martin Corporation, Manassas, Virginia	16
16 <i>Laser Removal of Paint on Pavement</i> MOXTEX, Incorporated, Orem, Utah	17
17 <i>Self-Contained Portable Device for SHRP Binder Testing: Field QC/QA Testing with the Duomorph</i> University of Illinois, Urbana-Champaign, Illinois	18
18 <i>New Principles of Design for Cutting Tools to Repair and Remove Pavements Based on the Effect of Lateral Propagation of Cracks Under Contact Loading</i> POTOK Centre, Kiev, Ukraine	19
19 <i>Aluminum Bronze Alloy for Corrosion-Resistant Rebar</i> Man-Tech Development, Inc., Mansfield, Texas	20
20 <i>Carbon Dioxide (Dry Ice) Cleaning to Remove Highway Road Markings and Stripes</i> Tomco Equipment Company, Loganville, Georgia	21
21 <i>Development of LED Light Source for Traffic Control Devices</i> The Last Resource, Inc., Bellefonte, Pennsylvania	22
22 <i>Use of Phase Change Materials to Prevent Overnight Freezing of Bridge Decks</i> University of Dayton Research Institute, Dayton, Ohio	23
23 <i>Lead-Based Paint Removal from Steel Structures</i> EMEC Consultants, Export, Pennsylvania	24
24 <i>Fiber-Optic Strain Sensor System for Long-Term Monitoring of Highway Structures</i> Simula Government Products, Inc., Phoenix, Arizona	25
25 <i>Basalt Fiber Composite Reinforcement for Concrete</i> Research and Technology, Inc., Madison, Wisconsin	26
26 <i>Conservation Control Load Switch Operational Tests</i> CLS Incorporated, Westerville, Ohio	27
27 <i>Automated Bridge Deck Anti- and Deicing System</i> University of Utah, Salt Lake City, Utah	28
28 <i>Corrosion-Resistant Low-Carbon Steels for Concrete Reinforcement</i> University of California, Berkeley, California	29

Project	Page
29 <i>Superelasticity-Based Materials for Bridge Rehabilitation</i> DPD, Inc., Lansing, Michigan Michigan State University, East Lansing, Michigan	30
30 <i>Rapid Replacement Composite Bridge No. 1</i> Kansas Structural Composites, Inc., Russell, Kansas.	31
31 <i>Cost-Effective Microwave Sensor to Detect Highway Road Conditions</i> University of Wyoming, Laramie, Wyoming	32
32 <i>Testing and Trial Deployment of a Cost-Effective and Real-Time Asphalt Pavement Quality Indicator System</i> TransTech Systems, Inc., Latham, New York	33
33 <i>Evaluation of a New Rehabilitation Technology for Bridge Piers with Composite Materials</i> West Virginia University, Morgantown, West Virginia	34
34 <i>Highway Guardrail Infrastructure: Safer Terminal Designs</i> Duke University, Durham, North Carolina	35
37 <i>In-Service Repair of Highway Bridges and Pavements by Internal Time Release of Repair Chemicals</i> Illinois Universities Transportation Research Consortium, Chicago, Illinois	36
38 <i>Paint Removal from Steel Structures: Testing and Demonstration of ElectroStrip™ Process</i> EMEC Consultants, Export and New Kensington, Pennsylvania	37
40 <i>Estimating Truck Attributes from Bridge Strain Data Using Neural Networks</i> University of Florida, Gainesville, Florida	38
43 <i>Robotic System for Underwater Bridge Inspection and Scour Evaluation</i> Kansas State University, Manhattan, Kansas	39
44 <i>Roller-Mountable Asphalt Pavement Quality Indicator Using Differential Microwave Signals</i> Iowa State University, Ames, Iowa	40
45 <i>Performance Evaluation of Basalt Fibers and Composite Rebars as Concrete Reinforcement</i> Research and Technology, Inc., Madison, Wisconsin South Dakota School of Mines and Technology, Rapid City, South Dakota	41
47 <i>Pavement Quality Indicator: Field Operational Testing and Product Transfer</i> TransTech Systems, Inc., Latham, New York	42
48 <i>Field Trial of Shape Memory-Based Rehabilitation System</i> DPD, Inc., East Lansing, Michigan Michigan State University, East Lansing, Michigan	43

Project	Page
50 <i>Damper Systems for Suppression of Bridge Stay Cable Vibrations</i> Construction Technology Laboratories, Inc., Skokie, Illinois	44
 SECTION 2: Active IDEA Projects	
41 <i>Field Testing with the Duomorph: A Self-Contained Portable Device for SHRP Binder Testing</i> University of Illinois, Urbana-Champaign, Illinois	46
42 <i>Dual-Core Fiber Optic WIM System</i> University of Connecticut, Storrs, Connecticut	48
46 <i>Fiber-Reinforced Polymer Honeycomb Short-Span Bridge for Rapid Installation</i> Kansas Structural Composites, Inc., Russell, Kansas Kansas Department of Transportation, Topeka, Kansas	51
49 <i>Automation of Legends Painting</i> Pavement Marking Technologies, Inc., Menlo Park, California	53
51 <i>Application of Advanced Composites to Steel Bridge Retrofitting</i> University of Delaware, Newark, Delaware	55
52 <i>Environmentally Friendly Passivating Coatings for Steel Rebars</i> Neely Industries, Inc., Butler, Pennsylvania University of South Florida, Tampa, Florida Florida Department of Transportation, Gainesville, Florida University of Rhode Island, Kingston, Rhode Island	58
54 <i>Novel Approach for Predicting Remaining Life of Concrete Bridge Structures</i> University of Arizona, Tucson, Arizona	61
55 <i>Design, Development, and Verification of an Advanced In Situ Shear Strength Test Facility for Asphalt Concrete Pavements</i> Carleton University, Ottawa, Ontario, Canada	65
56 <i>Bridge Inspection with Serpentine Robots</i> Carnegie Mellon University, Pittsburgh, Pennsylvania	69
57 <i>Stabilization of Landslides Using Wick Drains</i> University of Missouri, Rolla, Missouri	72
58 <i>Long Gauge-Length Interferometric Fiber-Optic Sensors for Condition Assessment of Bridge Structures</i> Pennsylvania State University, University Park, Pennsylvania	75
59 <i>Control Systems for Live Load and Live Load Effects on Bridges</i> University of Michigan, Ann Arbor, Michigan	79

Project	Page
61 <i>The Pavement Thickness Density Meter</i> INFRASENSE, Inc., Arlington, Massachusetts	81
62 <i>A New Technique for Characterizing Pavement Surface Profiles and Textures</i> Texas A&M University, College Station, Texas	83
63 <i>Manufacture and Testing of a Filament-Wound Composite Bridge Superstructure</i> University of Illinois, Urbana-Champaign, Illinois	85
64 <i>Quantitative Characterization of Asphalt Concretes Using High-Resolution X-Ray Computed Tomography (CT)</i> University of Texas, Austin, Texas	88
65 <i>Application of Shape Memory Alloys in Seismic Rehabilitation of Bridges</i> Georgia Institute of Technology, Atlanta, Georgia	91
66 <i>Development of An Innovative Connector System for Fiber-Reinforced Polymer Bridge Decks to Steel Stringers</i> West Virginia University, Morgantown, West Virginia	93
67 <i>All Composite Bridge Sidewalk</i> Foster-Miller, Inc., Waltham, Massachusetts	96
68 <i>Geocomposite Capillary Barrier Drain for Limiting Moisture Changes in Pavement Subgrades and Base Courses</i> University of New Mexico, Albuquerque, New Mexico	99
69 <i>Development of a Conductivity Spectrum Probe (CSP) for Predicting Chloride Permeability in Concrete</i> INFRASENSE, Inc., Arlington, Massachusetts	102
70 <i>Flamespray Coating as an Environmentally Acceptable Pavement Marking Technique</i> Research Triangle Institute, Durham, North Carolina	105
71 <i>Implementation of Tuned Dampers for Suppression Of Bridge Stay Cable Vibrations</i> Construction Technology Laboratories, Inc., Skokie, Illinois	107
72 <i>Improved Filtration of Wash Water Generated during Bridge Maintenance Painting</i> Georgia Tech Research Institute, Atlanta, Georgia	110
73 <i>Development of a Screed to Detect and Measure Segregation of HMA Pavements</i> Auburn University, Auburn, Alabama	112
74 <i>Adhesion Tool For Overcoating Risk-Reduction Analysis</i> Corrpro Companies Inc., Arlington, Virginia North Dakota State University, Fargo, North Dakota	114

Project	Page
75 <i>Automated Mobile Highway Sign Retroreflectivity Measurement</i> University of Missouri, Rolla, Missouri	116

SECTION 3: NSF/NRC-IDEA Cooperative Projects

1 <i>Control System for Highway Load Effects</i> University of Michigan, Ann Arbor, Michigan	120
2 <i>Pulse-Echo Tomographic Microwave Imaging Systems for Quantitative NDE of Civil Structures and Materials</i> University of California, Santa Barbara, California	121

APPENDIX

<i>Listing of IDEA Projects Awarded to Date in ITS-IDEA, Transit-IDEA, and High-Speed Rail IDEA</i>	123
---	-----

SECTION 1 COMPLETED IDEA PROJECTS

This section presents brief summaries of NCHRP-IDEA projects completed before the 2000 program year. The products from these projects have been applied or are available for further investigation for application to highway practice. The product status is described under each project.

ON-LINE REAL-TIME MEASUREMENT AND CONTROL OF AGGREGATE GRADATION IN ASPHALT PLANTS

NCHRP-IDEA Project 1

Felix Alba [Tel: (801) 264-8294, Fax: (801) 264-8293]

Felix ALBA Consultants Inc., Murray, Utah

Mike Worischeck and Steve Madrigal,

STAKER Paving and Construction Company, Salt Lake City, Utah

This IDEA project developed and tested a non-contact video imaging and analysis system (Figure 1) for continuous on-line measurement and flow control of aggregate gradation (size distribution) in an asphalt plant.

The system's hardware consists of a lamp and a line-scan video camera installed over feeder belts from each of the cold bins. The software system incorporates the principles of machine vision, image processing, stereology, and mathematical analysis. Raw images of the aggregates falling onto the master belt are gathered by frame grabbers and preprocessed by image processing boards connected to the data bus of a host computer. Additional image processing and particle recognition algorithms determine the chord-length distribution of aggregates from video images. The chord-length distribution is then transformed into volumetric (sieve) size gradations. Proportioning factors for the bins are applied to comply with the job mix formula, and belt feeder speeds are adjusted accordingly to deliver a uniform flow of aggregates automatically.

Field experiments at an asphalt plant show that the system can measure coarse aggregate gradation (3/4", 1/2", 3/8") with a reproducibility better than 2% and an accuracy (relative to standard sieving) better than 4% on each mesh. The system slightly underreported finer particles, which was attributed to agglomeration of particles under humid plant conditions. The problem was satisfactorily resolved using a semi-empirical procedure. The IDEA product is ready for field operational testing and marketing. The final report is available from the National Technical Information Service (NTIS # PB97-141642).

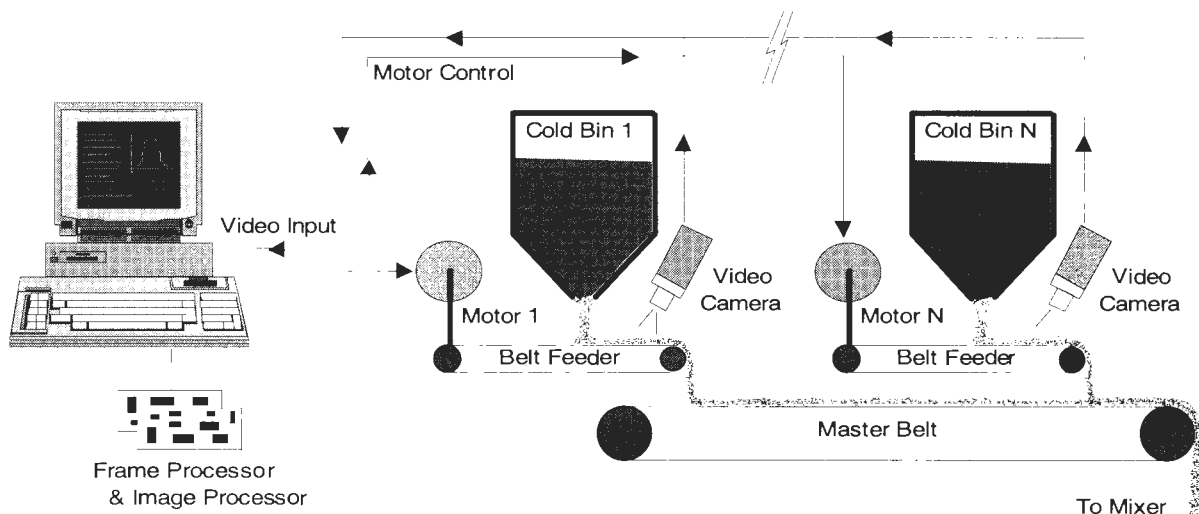

Figure 1

Aggregate gradation control technological concept.

A METHOD FOR MEASURING WATER-STRIPPING RESISTANCE OF ASPHALT/SILICEOUS AGGREGATE MIXTURES

NCHRP-IDEA Project 2

Tinh Nguyen [Tel: (301) 975-6718, Fax: (301) 990-6891] and Eric Byrd
National Institute of Standards and Technology, Gaithersburg, Maryland

This project developed techniques to assess the stripping resistance of asphalts on siliceous aggregates. The first technique, in situ measurement of the water layer at the asphalt/aggregate interface, is a nondestructive, quantitative technique based on Fourier transform infrared spectroscopy in the multiple internal reflection mode (FTIR-MIR). In this technique, water reaching the asphalt/siliceous aggregate interface is detected by the evanescent wave, which is produced by the total internal reflection of the infrared radiation (Figure 1). This technique provides information on the stripping of asphalt at the molecular level. The second technique relies on the use of a pneumatic pull-off adhesion tester combined with a porous stub that allows water to migrate through the asphalt film to the asphalt/aggregate interface. This reliable and easy to use method provided a rapid laboratory and field test for the water-stripping resistance of asphalt on aggregates.

A number of asphalts from the SHRP Materials Reference Library were used in this investigation. A correlation between bond strength and the amount or thickness of the water layer at the asphalt-aggregate interface was established and formed the basis for a nondestructive test based on FTIR-MIR for determining the water stripping resistance of asphalt-siliceous aggregate mixtures. The concept has proven feasible but the technique is limited to laboratory examination of field samples. The final report is available from the National Technical Information Service (NTIS # PB96-197249).

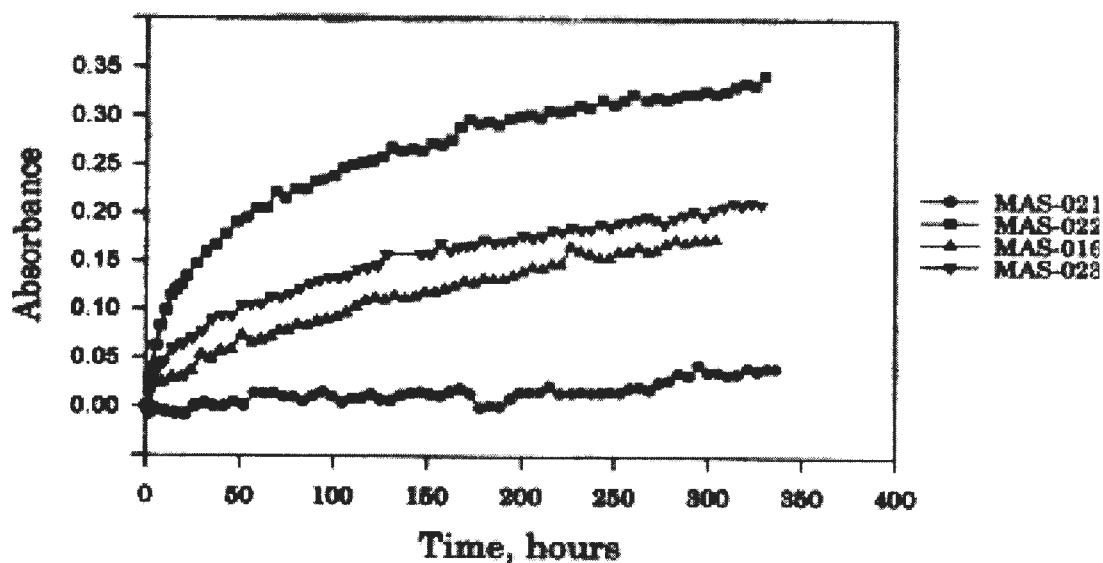

Figure 1

FTIR-MIR intensity of the water layer at the asphalt/siliceous substrate interface for different anti-stripping agents.

GUIDELINES FOR LOW-COST SPRAYED-ZINC GALVANIC ANODE FOR CONTROLLING CORROSION OF REINFORCING STEEL IN MARINE BRIDGE SUBSTRUCTURES

NCHRP-IDEA Project 3

Alberto A. Sagues [Tel: (813) 974-2275, Fax: (813) 974-3651]
University of South Florida, Tampa, Florida

Rodney G. Powers, Florida Department of Transportation, Gainesville, Florida

The project developed guidelines for using sprayed zinc (as a sacrificial anode system) for protecting reinforcing steel (acting as the cathode) from corrosion in marine bridge structures. Sacrificial cathodic protection by means of sprayed-zinc galvanic anodes is a low-cost alternative to conventional cathodic protection of these substructure components. The surface of the spalled concrete and exposed rebar is abrasively cleaned and sprayed with zinc, using commonly available metallizing equipment. An electrical connection between the zinc and the steel is established directly. Concrete patching is not needed unless required for structural reasons, in which case the zinc is applied over the repaired concrete and a stud is used to connect the steel with the sprayed zinc. The finished cost ranges from \$60 to \$120/m². The method is applicable to a wide variety of structural components.

Laboratory and field experiments demonstrated the feasibility of the proposed approach. Additional performance data were obtained in a large-scale field application (Figure 1). The fieldwork was carried out in collaboration with the Florida DOT during the rehabilitation of the Howard Franklin Bridge on Tampa Bay (State Project 15190-3487). The tests showed adequate probe and steel polarization (typically exceeding the 100-mV depolarization criterion) with moderate current demand (below 1 mA/sq. ft.) indicating continued cathodic protection of steel reinforcement in the substructure. Based on field results, a manual on the use of sprayed zinc for the protection of marine substructures was prepared. The product is undergoing large-scale field trials by the Florida DOT. A special two-page IDEA product report, *Sacrificial Sprayed-Zinc Galvanic Anode System for Corrosion Protection of Reinforced Concrete in Marine Substructures*, was released in June 1995. The final report is available from the National Technical Information Service (NTIS # PB97-141766).



Figure 1

Field installation, Bahia Honda Bridge,
Florida Keys.

EXPLORING THE FEASIBILITY OF REPLACING LATEX WITH ASPHALT EMULSION FOR USE IN BRIDGE DECK OVERLAYS

NCHRP-IDEA Project 4

Jan Olek, Menashi D. Cohen [Tel: (317) 494-5018, Fax: (317) 496-1364],
and Sidney Diamond, Purdue University, West Lafayette, Indiana

This project explored the feasibility of using asphalt emulsion as a low-cost replacement for latex in portland cement concrete for highway applications. Research results showed that addition of emulsion reduced the workability and compressive and flexural strengths of concrete as compared with conventional concrete. The addition of emulsion also increased the amount of entrained air in concrete, which partly accounted for the strength reduction. The asphalt-modified concrete, however, showed excellent freeze-thaw durability (Figure 1). Moist curing appeared to have a better effect on strength development than air curing. Tests also showed that using pozzolanic materials (fly ash or silica fume) in combination with asphalt emulsion significantly reduced the chloride permeability of mortars.

Additional research and field evaluation are needed for the implementation of this product for highway applications. The final report is available from the National Technical Information Service (NTIS # PB95-267704).

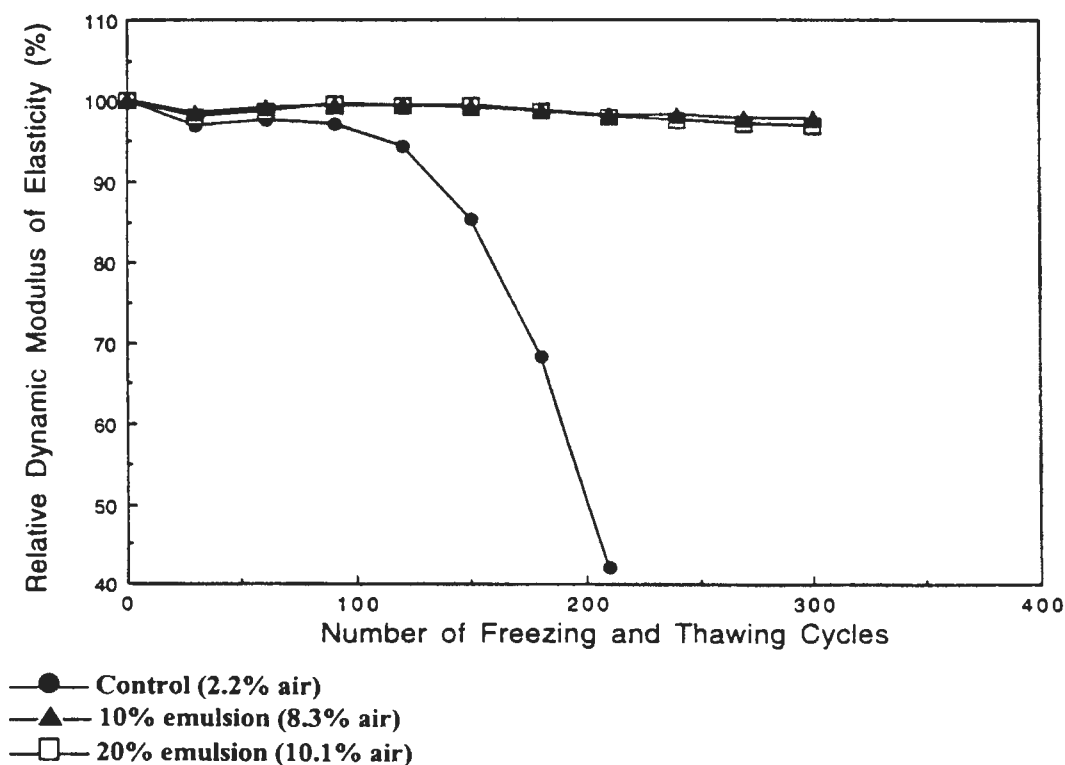

Figure 1

Freezing and thawing test results for plain and asphalt emulsion-modified concrete.

MAGNETIC RESONANCE FOR IN SITU DETERMINATION OF ASPHALT AGING AND MOISTURE CONTENT

NCHRP-IDEA Project 5

J. Derwin King [Tel: (210) 684-5111, Fax: (210) 647-4325] and Qing Wen Ni
Southwest Research Institute, San Antonio, Texas

This project developed and tested a magnetic resonance-based system for in-motion inspection of asphalt for rapid determination of pavement aging, moisture content, and the condition of asphalt concrete roadways.

A set of asphalt samples from the SHRP Reference Materials Library was used, representing a wide variation in properties that affect asphalt aging. The results showed good correlation of the nuclear magnetic resonance (NMR) data with the viscosity parameters and with aging induced by loss of volatiles and by accelerated oxidation. Electron proton resonance (EPR) studies provided additional information and correlations. EPR studies of neat asphalts showed typical hydrocarbon response from all samples plus a large multippeak vanadium spectrum from some samples. This EPR vanadium signal provides a basis for correction of the NMR data to make the pavement inspection independent of the types of asphalts and aggregates.

The combination of NMR and EPR techniques was shown to be an effective tool for assessing asphalt condition in pavements. The two resonance systems can use the same magnet and be easily integrated to work in tandem to determine asphalt condition. The system can be mounted on a small trailer for mobile in situ inspection. A recommended field design configuration is shown in Figure 1. Extensive field verification of the system is required for the IDEA product transfer. The final report is available from the National Technical Information Service (NTIS # PB95-267688).

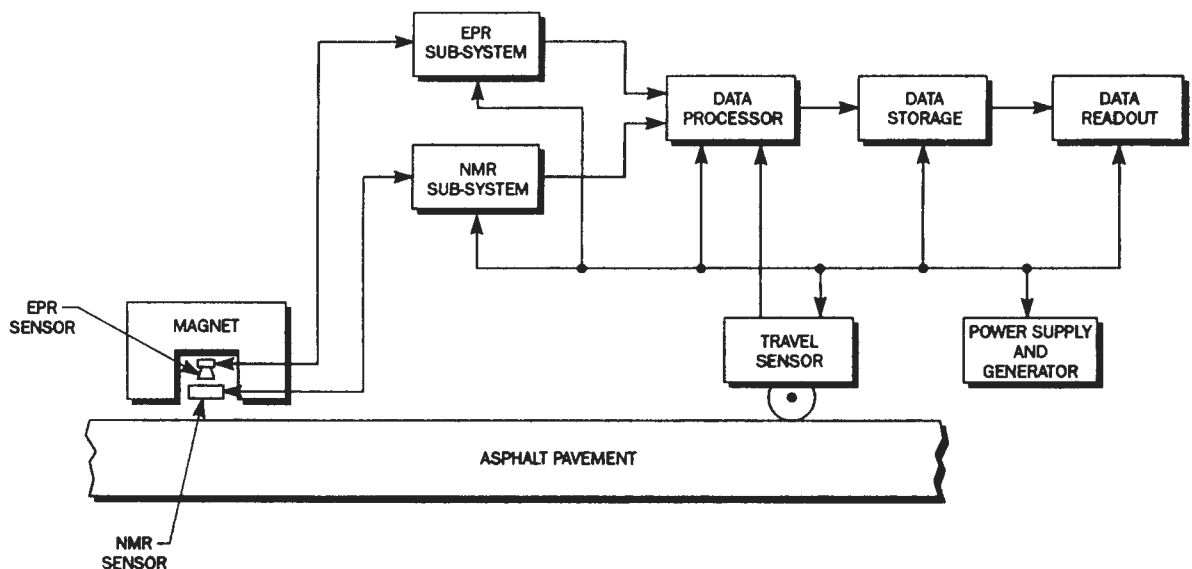

Figure 1

MR system for in situ asphalt inspection.

EXCOGITATED COMPOSITE MULTIFUNCTIONAL LAYER FOR PAVEMENT SYSTEMS

NCHRP-IDEA Project 6

Barry J. Dempsey [Tel: (217) 333-3963, Fax: (217) 333-4464]
University of Illinois, Urbana-Champaign, Illinois

The project evaluated a concept of a three-dimensional composite layer design for pavement construction for improved performance and service life. The excogitated composite multifunctional (ECM) layer (Figure 1) will satisfy multiple functions in the pavement system by providing for subbase layer-subgrade separation, subbase shear strength, subbase tensile strength, drainage, and protection of the subgrade from surface infiltration.

The work involved material selection and design and fabrication of the composite layer. A number of synthetic and natural materials were evaluated and several performance-related parameters of the layer were measured. The layer strength was increased significantly by changing the polymer blend in the polyethylene structure and by utilizing a stiffer geotextile. The load-deflection relationship and shear stress for this new layer also showed improvements.

The composite layer was evaluated and compared in large-scale laboratory tests. A test cell, 6 ft. by 6 ft. by 40 in., was constructed with an overhead frame for mounting a hydraulic ram to perform dynamic testing of the composite layer. Load deformation tests showed that the composite layer performed far better than the geotextile and geogrid sections and sections with no separation layer. The large-scale laboratory tests were followed by a limited field test of the composite layer with satisfactory performance results.

The composite layer now needs to be tested in a full-scale field setting. The ECM layer can be shipped to the construction site in rolls and can be easily placed by roll-out procedures similar to those used for geotextiles. The investigating team is working with the Illinois Department of Transportation to identify pavement sites during the 1996 construction season. Potential projects for testing include major highway or airport systems, low-volume roads, thin pavement overlays, and railroad track systems. After field verification experiments, a cost-benefit analysis is planned by the investigator to establish the efficiency of ECM pavement layers. The final report is available from the National Technical Information Service (NTIS # PB96-154414).

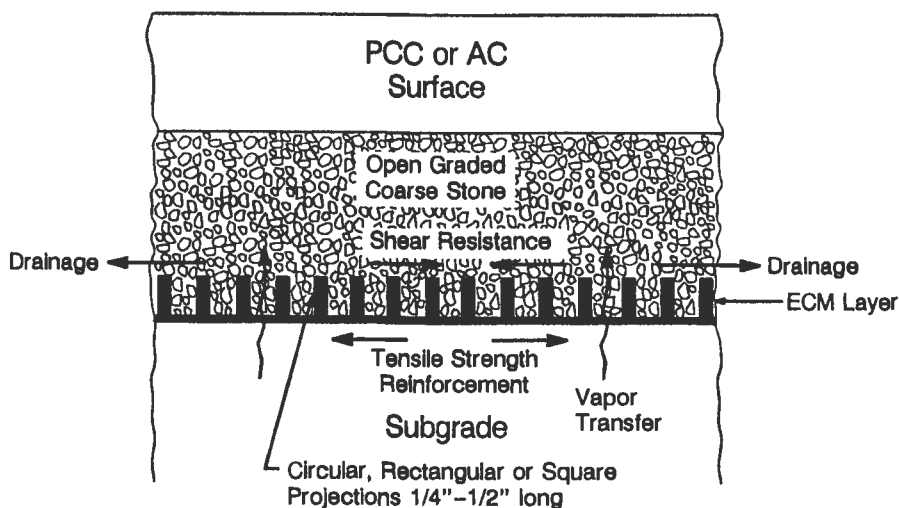

Figure 1

ECM layer concept and functions.

STRATEGY FOR COATING STRUCTURAL STEEL WITHOUT STRINGENT BLASTING REGULATIONS

NCHRP-IDEA Project 7

Simon Boocock [Tel: (412) 687-1113, Fax: (412) 697-1153]

Steel Structures Painting Council, Pittsburgh, Pennsylvania

The project developed and evaluated an environmentally safe technique for applying durable protective paint coating on structural steel without the need for blast cleaning. The concept is illustrated in Figure 1.

The process employed new high penetration primers with low or non-organic volatiles. The paint application technology involved embedding collapsible glass microspheres in the primer, which were then broken to interlock the primer with the topcoat. Fracturing the spheres provides a surface profile that "locks in" the topcoat and ensures a strong bond between the primer and the topcoat. Laboratory tests showed that thermal spray-coating systems employing non-volatile organic compound penetrating sealers loaded with glass microspheres are a viable option for overcoating aged alkyd paints. The addition of glass microspheres to the penetrating primer, however, had no significant effect on the performance of the thermal spray-coating systems.

Microscopic examination of the embedded broken microspheres indicated the potential for enhanced adhesion between the primer and the thermal spray topcoat. The liquid applied topcoat was also found to be a viable option for overcoating aged alkyd systems.

A series of factorially designed laboratory tests was performed in accordance with standard procedures to determine the effectiveness of the coating system regarding adhesion, impact

resistance, and corrosion protection. The results were satisfactory but not significantly superior to the current practice.

The implementation of this new painting process on highway steel bridge structures will require extensive testing in collaboration with state highway agencies. No additional project action is planned by NCHRP-IDEA. The final report is available from the National Technical Information Service (NTIS # PB96-147996).

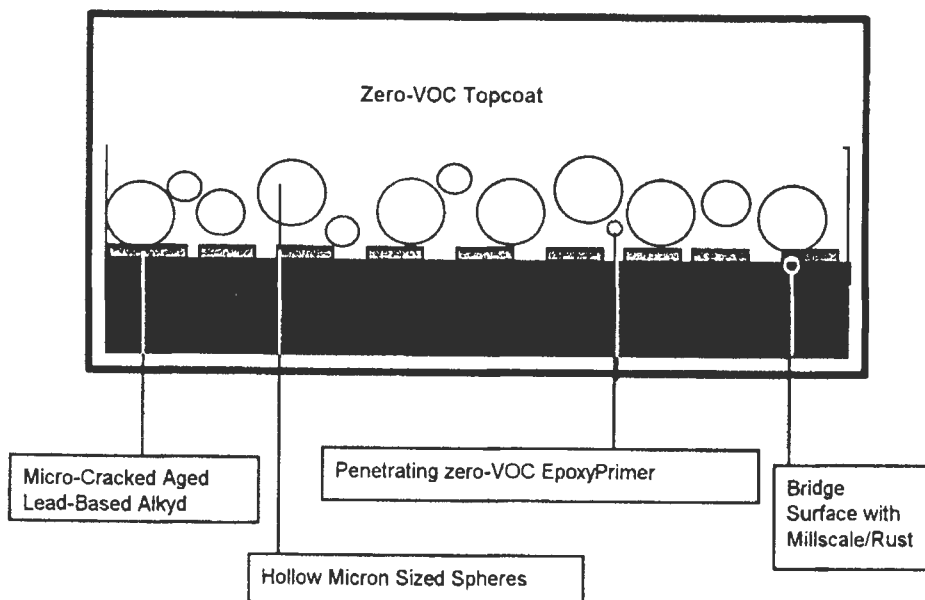

Figure 1

Product applied to bridge use.

CONSERVATION TRAFFIC CONTROL LOAD SWITCH

NCHRP-IDEA Project 8

Gregory A. Filbrun [Tel: (614) 895-1212, Fax: (614) 895-1213], Paul Wiese, and Greg Winthrow, CLS Incorporated, Westerville, Ohio

The project developed and tested a new microprocessor-based switch system (Conservation Traffic Control Load Switch), which significantly enhances the service life of traffic lamps by reducing the initial current surge in the filament coil. The conservation load switch system mitigates early lamp failure by increasing the voltage to the lamp over an 80-msec ramp-up period and then regulating it at a preset level somewhat below the standard line voltage. The prototype switch system was shown to function satisfactorily in the traffic control unit (signal cabinet). The system uses much less (about 30% less) electrical energy to operate the lamp and can be easily retrofitted into existing applicable signal cabinets. It uses the same connector, housing, and mechanical packaging as the standard National Electrical Manufacturers Association (NEMA) Model 170 and Model 200 traffic control load switch units. It can potentially meet all NEMA and Institute of Transportation Engineers (ITE) specifications. The switching system can be installed within a minute in any unmodified signal cabinet (Figure 1).

Operational tests and field evaluations of the switch system were performed. Over 100 units were assembled and sent to a number of state highway agencies for testing. The feedback from highway agencies confirmed the laboratory test results. A continuation project was awarded (NCHRP-IDEA #26) to perform additional field operational tests of the switch system in collaboration with state highway agencies and to develop product transfer and marketing strategies.

A special two-page IDEA product report, *Microprocessor-Based Lamp Switch System Quadruples Traffic Lamp Life and Prevents Early Lamp Burn-out*, was released in September 1995. The final report is available from the National Technical Information Service (NTIS # PB97-143838).



Figure 1

Installation of conservation load switch in standard cabinet.

CORROSION-RESISTANT STEEL REINFORCING BARS

NCHRP-IDEA Project 9

David Darwin [Tel: (913) 864-3826, Fax: (913) 864-3199], Carl E. Locke, Jr., Matthew R. Senecal, Jeffrey L. Smith, and Shawn M. Schwensen, University of Kansas, Lawrence, Kansas

The project evaluated the corrosion resistance and mechanical properties of steel rebars produced by new microalloying and rolling procedures that exhibit superior corrosion resistance properties. The bars possess a lower carbon content than is usual in U.S. practice and contain copper, chromium, and phosphorus as additional alloying elements. The phosphorus content exceeds that allowed in ASTM specifications. The bars are quenched and tempered immediately after the rolling operation.

Test results (corrosion potential and time-to-corrosion) showed that microalloying decreased the corrosion rate by one-half compared with conventional steel (Figure 1). Quenching and tempering heat treatment in conjunction with microalloying further enhanced the corrosion resistance of steel. The apparent corrosion-resisting mechanisms involve the reduction of microfractures in the surface from the rolling operation due to the quenching and tempering process and the formation of a corrosion-retarding layer of copper chloride–copper hydroxide and iron–chromium oxide at the steel surface. The latter is a poor conductor and thus reduces the corrosion rate. Quenching and tempering had a beneficial effect on the mechanical properties of the steel. Both the yield and tensile strengths were improved. The test results also showed that a phosphorus content in excess of that allowed under current ASTM requirements did not cause the corrosion-resistant steel to be brittle. The new steel also performed well when used in conjunction with epoxy coating.

Extensive field validation tests are required to transfer project results to practice. The results will be presented to ASTM Subcommittee A01.05 on Steel Reinforcement for consideration of specifications similar to ASTM A 615. The final report is available from the National Technical Information Service (NTIS # PR96-147988)

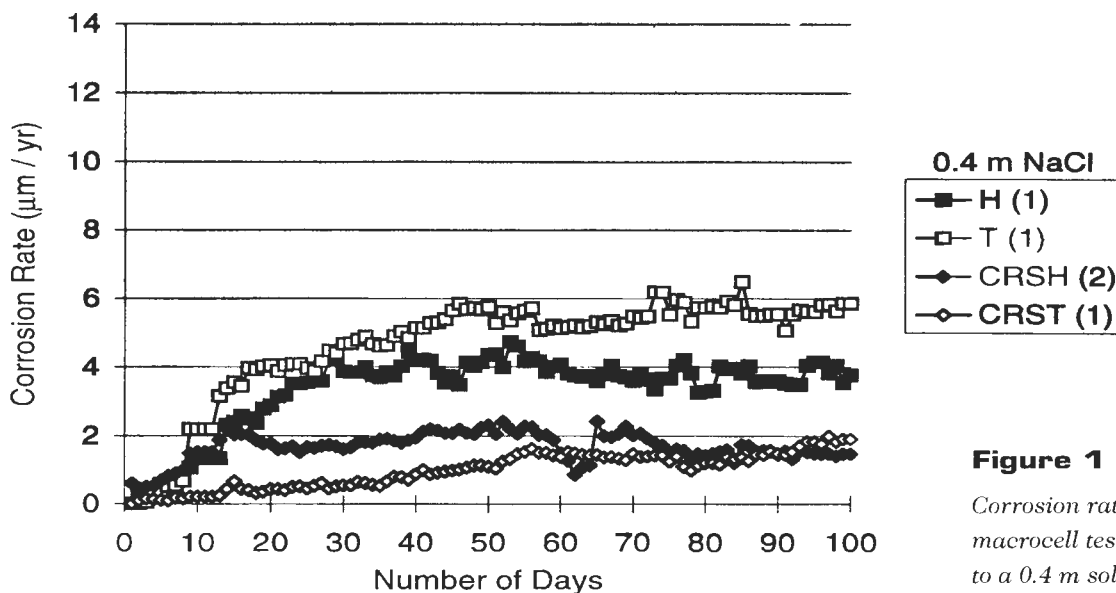

Figure 1

Corrosion rate versus time for macrocell test specimens subjected to a 0.4 m solution of NaCl.

METALLIC COATING FOR CORROSION PROTECTION OF STEEL REBARS

NCHRP-IDEA Project 10

Angel Sanjurjo [Tel: (415) 859-5215, Fax: (415) 859-2111], Kai Lau, David Lowe, Palitha Jayaweera, and Gopala Krishnan
SRI International, Menlo Park, California

The project was a follow-up investigation from a previous SIIRP-IDEA project in which a corrosion-resistant Si-Ti coating on steel rebars was produced using the fluidized bed technology. The current project was intended to scale up the process to coat rebars up to 3 ft long as well as to evaluate the coated rebars for corrosion resistance, structural integrity, flexibility, and mechanical properties.

A bench-scale reactor system was designed for coating 3-ft-long steel rebars. The scale-up reactor system appears feasible but may not be adaptable for commercial scale use. The researchers, however, discovered that a strong and coherent coating could be produced simply by spray painting the Si-Ti mixture (along with a flux) followed by a low-heat treatment at about 600°C (Figure 1). This process appears more practical for scaling up for commercial use than the more complex fluidized bed technology.

Because the paint-and-heat or sprayed coatings are not sacrificial, they will provide much superior corrosion protection for a long time. Corrosion tests showed that these coatings reduced the corrosion rate of steel rebars in chloride environments by over one order of magnitude. The preliminary projected cost for the coating appears similar to that of polymer coatings.

The investigators are working closely with an industrial rebar coater, Western Coating of Oregon. Based on user input, conditions similar to those expected to be found in industrial production are being simulated. A broad user demonstration of the method is also planned by the investigator. The final report is available from the National Technical Information Service (NTIS # PB96-148002).

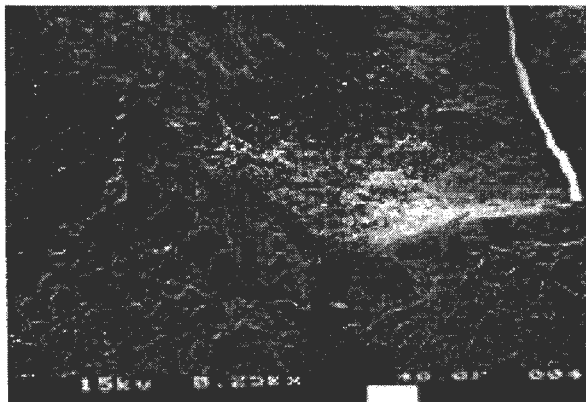

Figure 1

Scanning electron micrograph of coating prepared by paint-and-heat metallization.

REHABILITATION OF STEEL BRIDGES THROUGH THE APPLICATION OF ADVANCED COMPOSITE MATERIALS

NCHRP-IDEA Project 11

Dennis R. Mertz [Tel: (302) 831-2735, Fax: (302) 831-3640], University of Delaware, Newark, Delaware

This project evaluated the feasibility of using advanced composite materials for rehabilitation of steel highway bridges as an alternative to conventional repair methods. Stage 1 work performed modeling, fabricating, and testing of two flange repair schemes and proved the feasibility of the concept. Service-load testing on the repair schemes verified that the composite plates increased the stiffness of a section. A finite element model was applied to determine the desired geometry of the composite plate. Rehabilitation schemes were developed and tested for a variety of field geometries. Figure 1 shows various rehabilitation concepts. Test results showed good agreement with model prediction for stiffness enhancement. Increases in girder flexural modules of 20% to 30% were found to be attainable, which corresponds to the level of losses expected to be of concern in deficient bridge girders. Sandblasting the steel surface and using a saline pretreatment resulted in best durability for most adhesives. Results also show accelerated bonding through induction heating to be a viable rehabilitation technique in the field. Work in Stage 2 involved additional service load testing of fabricated scale beams, adhesive durability testing, and large scale testing of composite repair of both virgin and corroded steel beams. The results show improved strength and fatigue life of steel components by composite materials. A failure mode of concern is that due to bond failure, which occurred frequently in small tests. This failure, however, did not occur in large girder tests. Field validation of the technique is required for product transfer to practice. This is planned in a follow-up NCHRP-IDEA project in collaboration with the Delaware Department of Transportation. The final report is available from the National Technical Information Service (NTIS # PB97-141964).

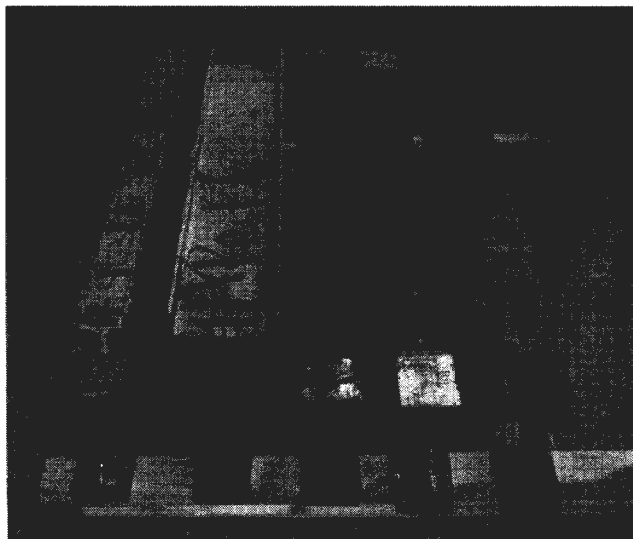

Figure 1

Basic rehabilitation geometries.

ADVANCED TESTING OF AN AUTOMATIC NONDESTRUCTIVE EVALUATION SYSTEM FOR HIGHWAY PAVEMENT SURFACE CONDITION ASSESSMENT

NCHRP-IDEA Project 12

Sidney Guralnick [Tel: (312) 567-3549, Fax: (312) 567-3634] and Eric S. Suen
Illinois Institute of Technology, Chicago, Illinois

The project refined and field-tested a prototype nondestructive evaluation system previously developed in an FHWA-sponsored project. The system utilizes the Shadow Moiré interferometry method and measures both vertical surface displacement and changes in slope of surface distress. The IDEA research focused on improving the Shadow Moiré inspection technology and completing a comprehensive user-friendly software package to assess road surface distress. Improvements involved an increase of maximum vehicle acquisition speed of 22%, new light emitters with special horizontal condensers to improve interference fringe pattern contrast, lightweight grating as opposed to two smaller gratings for greater road coverage, and a more accurate distance measuring system. Refinements in post-processing included rewriting C-based image analysis algorithms so that they run under the Pentium personal computer (PC) processor rather than slow video processors. Improvements in image digitization were also realized, such as improved image data integrity and large increases in throughput, allowing for faster post-processing of videotape images.

The prototype road inspection vehicle (Figure 1) was an enclosed uni-axle trailer and was capable of acquiring road surface distress information at velocities up to about 55 mph, allowing users to categorize, rate, and determine roadway locations of all out-of-plane surface deformations along a particular roadway. The cost of the road inspection system is estimated to be about \$60,000.

Ford Motor Company has donated a full-size field vehicle to replace the trailer system for performing field tests. The system is ready for field validation under operational conditions. State agencies and private consulting companies have shown interest in using the system in the field.

A special two-page IDEA product report, *Surface Condition Assessment and Profiler System for Pavements Using Shadow Moiré Interferometry*, was released in June, 1995. The final report is available from the National Technical Information Service (NTIS # PB97-151617).



Figure 1

Automated road inspection vehicle during field testing.

NEW ADDITIVE FOR IMPROVED DURABILITY OF CONCRETE

NCHRP-IDEA Project 13

Jack E. Stephens [Tel: (203) 486-4014, Fax: (203) 486-2298] and James Mahoney,
University of Connecticut, Storrs, Connecticut

James R. Humphrey, Todd Chemical, Cheshire, Connecticut

The project evaluated a class of organic compounds (diammonium salts of alkenyl dicarboxylic acids) as additives for concrete that may improve its durability against freezing and thawing and reinforcement corrosion. The material also reduces heavy metal leachate, potentially making environmentally acceptable the use of incinerator ash (both bottom and fly ash) in concrete.

Freeze-thaw, compression, and indirect tension tests were performed to determine the effect of additives on concrete properties. Porosity and permeability measurements also were done to determine their effectiveness in preventing access of chloride salt solution to the steel. Results showed a rather adverse effect of admixtures on concrete workability and strength. Also, the permeability was not significantly improved. However, the concrete showed excellent freeze-thaw resistance (Figure 1). Furthermore, leaching tests showed that the admixtures significantly decreased the leaching of lead from the concrete. The admixtures have potential to be effective air-entraining agents for concrete for improved freeze-thaw durability. No additional action is planned by NCHRP-IDEA. The final report is available from the National Technical Information Service (NTIS # PB96-147970).

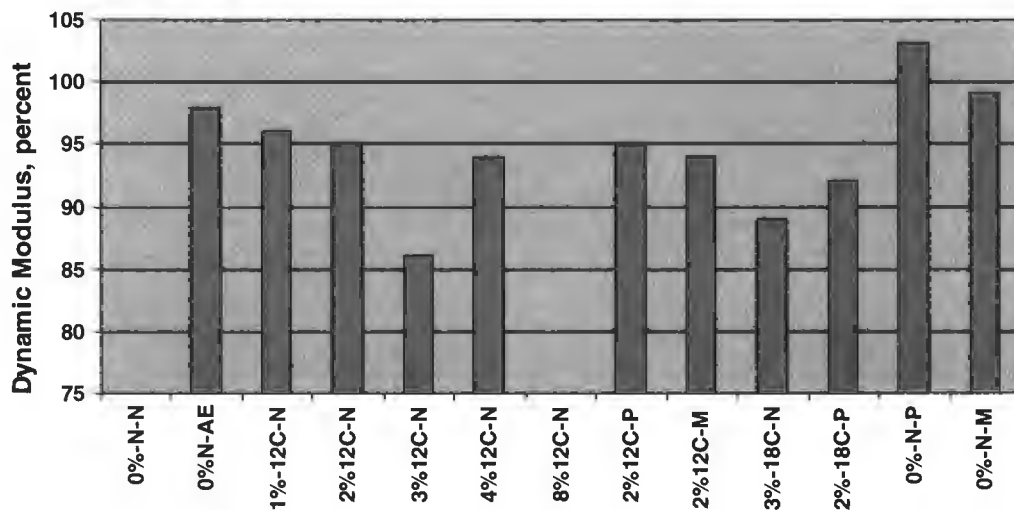

Figure 1

Freezing and thawing test results for concrete specimens containing organic additives.

UNREINFORCED, CENTRALLY PRESTRESSED CONCRETE COLUMNS AND PILES

NCHRP-IDEA Project 14

D.V. Reddy [Tel: (407) 367-3443, Fax: (407) 367-3885],
Florida Atlantic University, Boca Raton, Florida

Paul F. Csagoly, Clearwater, Florida

This project tested the concept of centrally prestressed unreinforced concrete (CPUC) columns and piles for application to highway structural systems (Figure 1). In the CPUC column, the innate incompatibility between concrete and steel is eliminated by removal of the latter; but flexural resistance and ductility are restored by the application of a centrally located prestressing tendon or closely spaced strands. This concentration of steel results in a significant increase in concrete cover for better corrosion protection without loss of strength.

Specimens of CPUC columns and piles were evaluated to assess the feasibility and practicality of the concept. Test results showed that the prestressed column provided a substantial increase in effective cross section to withstand both axial and shear loading compared to conventional reinforced concrete columns. Figure 2 illustrates the second innovation, labeled as an extended performance flexural (EPF) device. The EPF device is not a shock isolator, but a completely structural device intended for connecting pier columns to either the superstructure or the substructure, or both, and transmitting considerable moments while permitting large rotations. It sustained several cycles of rotations up to (10% without damage. Analytical application of the EPF device to a bridge structure indicates close to one order of magnitude increase in the fundamental period of vibration and a decrease of 65% in the equivalent static lateral force used in earthquake design. Large-scale field tests on actual highway structures are needed for implementation of this IDEA product. The final report is available from the National Technical Information Service (NTIS # PB97-160816).

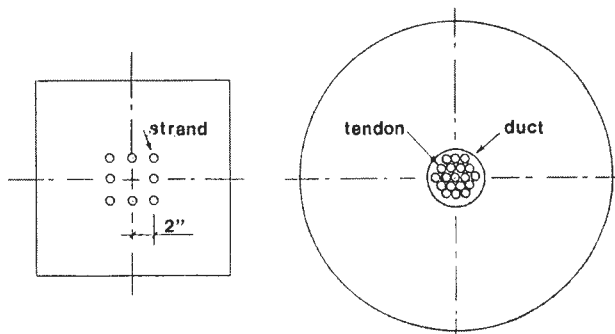

Figure 1

Cross section of CPUC pile and column.

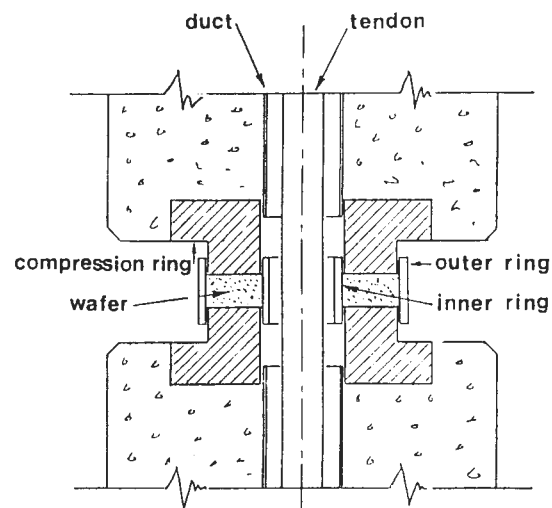

Figure 2

EPF device schematic.

PORTABLE LASER ROAD CREW WARNING SYSTEM

NCHRP-IDEA Project 15

Keith Higgenbotham [Tel: (703) 367-6838, Fax: (703) 367-2370] and Rudolph Gammarino, Lockheed Martin Corporation, Manassas, Virginia

The project applied a laser technology to develop a portable warning system to improve safety for highway workers (Figure 1). The system consists of a battery-powered master laser transmitter mounted on a traffic cone, one or more laser receiver-transmitters also mounted on traffic cones, and a worker notification warning system. A pulsed laser beam from the master laser transmitter is directed toward the laser receiver-transmitter located at the end of taper. The beam is detected by the receiver at that point. The detection event triggers the laser that is co-located with the receiver, and it transmits laser pulses toward a second receiver located at the end of the work zone. The retransmitted beam is received by the final detector at the end of the work zone. If the first beam or the retransmitted beam is interrupted by an errant vehicle at any point, the lack of a laser signal at the final receiver causes an electrical signal to be generated that activates an alarm system, notifying workers to take evasive action. In this way, the laser beam acts as an electro-optical barrier along the taper and the work zone.

The system configuration can be modified to suit the size and nature of highway maintenance activity. A field demonstration was carried out at the contractor's facility in California with satisfactory performance. The final report is available from the National Technical Information Service (NTIS # PB97-143861).

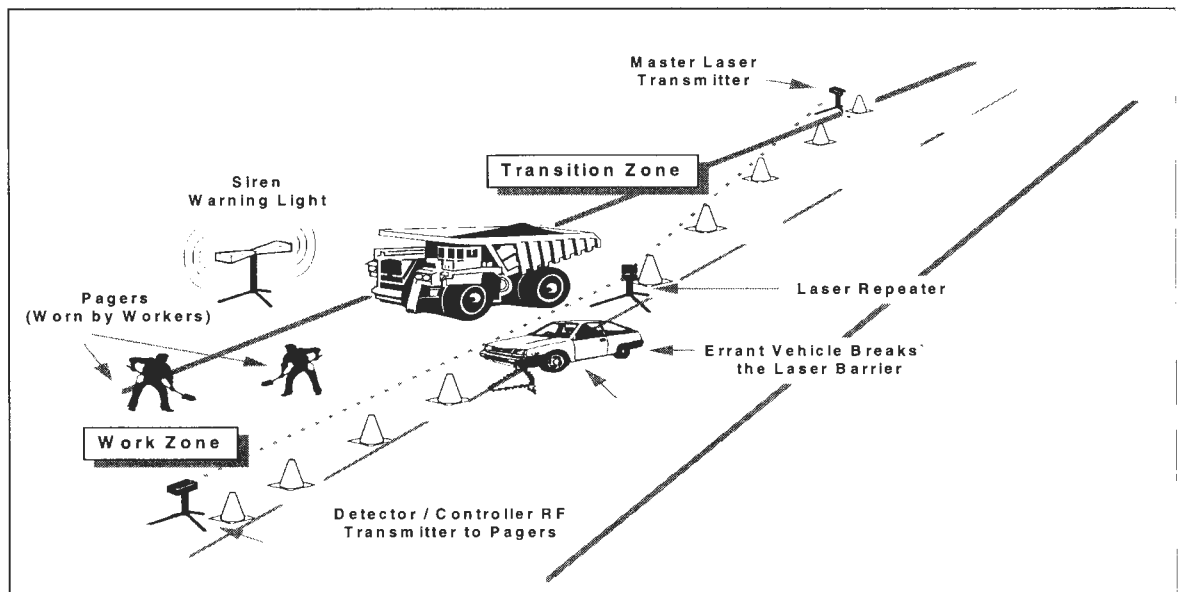

Figure 1

Road crew portable laser warning system.

LASER REMOVAL OF PAINT ON PAVEMENT

NCHRP-IDEA Project 16

Hans Pew [Tel: (801) 225-0930, Fax: (801) 221-1121] and James Thorne, MOXTEK, Incorporated, Orem, Utah

The goal of this project was to develop a mobile highway paint removing system based on pulsed laser. The concept was to apply a succession of short, intense laser pulses that create destructive shock waves rather than heating paint to the point where chemical reactions occur. The product's impact will be (a) the elimination of the usual environmental contaminants such as grit, dust, smoke, and chemicals; (b) prevention of damage to pavement during paint removal; and (c) complete removal for compliance with federal codes that require no visible trace of temporary markings on newly constructed roadways. Work in the initial phase of the project established the feasibility of using a laser to remove markings from highway materials. A prototype portable laser was developed for removal of paint from the pavement of highways, parking lots, and airfield runways. The removal was clean, but not fast. Several methods that would possibly speed the removal were defined and investigated. The dominant variables were power density (watts/cm²) and pulse duration. Work then focused on selecting and testing a laser that could be used to demonstrate removal of markings in field conditions. The laser needed to meet certain specifications and still remove a painted stripe as rapidly as possible (hopefully at a rate that is competitive with sandblasting). The requirements included reliability in a highway environment (flash lamps easy to change, realignment not necessary, etc.), optimum pulse energy density, pulse duration and wavelength, and, most important, maximum average power for the size and cost of the laser. Consequently a new more powerful system was designed.

The present system uses a new high-power laser that produces short pulses at 1.06- μ m wavelength and has shown promising results on asphalt and concrete surfaces in laboratory tests. The paint removal efficiency of the laser system also depends on the type of the paint. Epoxy-based paints were removed with better efficiency than other paints. The system was attached to a mobile carriage for field demonstration. Further optimization and field trials are needed in order to establish the effectiveness of the system in the field.

Demonstrations of the prototype mobile unit on highway or parking lot markings or both are planned for the departments of transportation of nearby states, starting with Nevada. It will also be demonstrated to companies that deal in highway markings. If these demonstrations create sufficient interest, then commercially viable field units will be designed and implemented for removal of highway markings. The final report is available from the National Technical Information Service (NTIS # PB2000-104071).

SELF-CONTAINED PORTABLE DEVICE FOR SHRP BINDER TESTING: FIELD QC/QA TESTING WITH THE DUOMORPH

NCHRP-IDEA Project 17

Samuel H. Carpenter [Tel: (217) 333-4188, Fax: (217) 333-9464], University of Illinois, Urbana-Champaign, Illinois

The project developed a portable field device (Duomorph) for testing asphalt binder properties that will complement the SHRP (Strategic Highway Research Program) dynamic and bending beam rheometers. Figure 1 shows typical Duomorph assemblies. The research was intended to improve and refine Duomorph technology by using new piezoelectric materials, sensors, improved digital technology, newer electronic equipment, and finite element modeling to make and validate a self-contained portable device for field use at temperatures ranging from -28°C to $+80^{\circ}\text{C}$, the Superpave range of temperature. In Stage 1, a Duomorph testing system (Duomorph Asphalt Rheology Test or DART) was assembled and shakedown tests were performed in the laboratory using SHRP reference asphalt binders. The tests have demonstrated that the DART system is durable and provides data that compare well with standard SHRP equipment. A 2-inch gauge size appears satisfactory for testing. Stage 2 work performed a functional testing system and extensive experimentation to establish operational characteristics at various temperatures as required in SHRP binder specifications. A supplemental award (NCHRP-IDEA Project 41) has been made for further refinement of the device and for fieldtesting and demonstration to state highway agencies. The final report is available from the National Technical Information Service (NTIS # PB97-143879).



Figure 1

Duomorph assemblies.

NEW PRINCIPLES OF DESIGN FOR CUTTING TOOLS TO REPAIR AND REMOVE PAVEMENTS BASED ON THE EFFECT OF LATERAL PROPAGATION OF CRACKS UNDER CONTACT LOADING

NCHRP-IDEA Project 18

Igor Sveshnikov [Tel: +7 (044) 263-84-07, Fax: +7 (044) 265-09-95],
POTOK Centre, Kiev, Ukraine

This project developed tool designs for energy-efficient cutting and removal of concrete pavement. The concept takes advantage of the lateral propagation of cracks in concrete produced by using indentors with unconventional asymmetric geometric shapes (Figure 1). The production of lateral cracks in hard rocks facilitates the breaking and removal of material with reduced energy consumption and improved efficiency and productivity. The effectiveness of various indenter configurations was investigated for crack initiation and propagation in rocks, such as limestone, and model materials, such as unreinforced optical glass. Results of theoretical modeling and experimental tests show that cutters with an asymmetric elliptical insert are most effective in producing cracks and breaking the rocks with considerably reduced energy consumption. Based on theoretical and experimental work, the tool designs were developed and prototypes were fabricated and delivered.

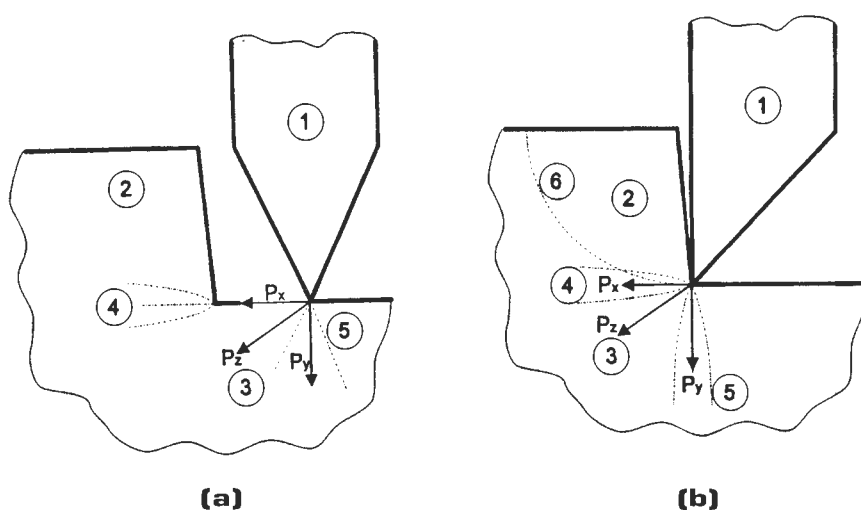

Figure 1

Crack propagation of friable material under contact of (a) indenter of traditional shape and (b) indenter of special shape (1, cutter; 2, rock; 3, element of cutting strength; 4, system of subhorizontal cracks; 5, system of vertical cracks; 6, trajectory of rock mass destruction).

ALUMINUM BRONZE ALLOY FOR CORROSION-RESISTANT REBAR

NCHRP-IDEA Project 19

David Stein [Tel: (817) 473-1996, Fax: (817) 463-1997],
Man-Tech Development, Inc., Mansfield, Texas

This project evaluated aluminum bronze alloy as a possible alternative to steel for corrosion-resistant concrete reinforcement. Rebars from aluminum bronze alloy were fabricated for laboratory and field evaluations. Initial tests showed rather low mechanical properties for alloys as compared to steel. Further work focused on improving the strength and mechanical properties of the alloy by optimizing its composition and fabrication process. The process eliminated the hot rolling operation and entailed direct continuous casting of aluminum bronze to a near net size and shape of rebar followed by cold drawing the bar to finished size and shape. The cold drawing operation increased the strength of aluminum bronze rebars close to that of mild steel rebar, meeting the ASTM specifications (Figure 1). In corrosion tests, the aluminum bronze alloy showed high resistance to seawater corrosion as compared to mild steel and ductile steel (Figure 2). Cost analysis of aluminum bronze rebars showed a cost of \$0.85 per lb. as compared to \$1.20 per lb. for stainless steel at current metal prices. The final report is available from the National Technical Information Service (NTIS # PB97-141972).

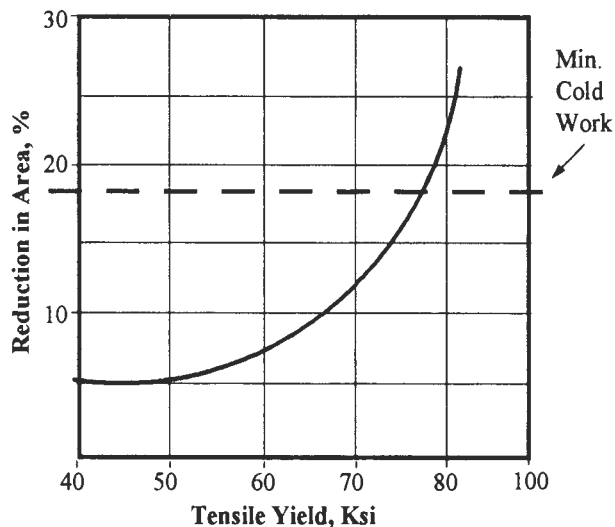

Figure 1

Tensile yield strength of aluminum bronze as a function of strain hardening.

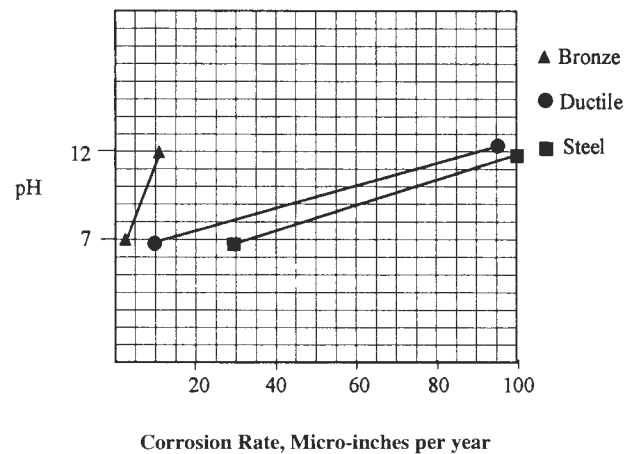

Figure 2

Corrosion rates of three alloys to chloride ion corrosion.

CARBON DIOXIDE (DRY ICE) CLEANING TO REMOVE HIGHWAY ROAD MARKINGS AND STRIPES

NCHRP-IDEA Project 20

Andrew W. Pazahanick [Tel: (800) 832-4262, Fax: (404) 985-9179],
Tomco Equipment Company, Loganville, Georgia

This project developed and tested an environment-friendly process for pavement paint removal using CO₂ pellets. The system uses either air or an electric motor to propel the dry ice pellets. Dry ice pellets are directed at an accelerated rate from a centrifugal system through a gun-like nozzle attached to a single hose (Figure 1) onto the pavement for cleaning paint markings. The centrifugal system propels dry ice pellets at a significantly higher rate than the pneumatic system.

The pneumatic CO₂ cleaning system showed excellent results on core samples. However, it was impracticable to use a 2-inch nozzle to remove road marks and stripes on highways. In addition, the exit pattern from the centrifugal system needed to be designed for removing various sizes of road markings and stripes. The test results, however, show that the process is especially suitable for cleaning road markings and stripes. The process can, therefore, be used to restore the brilliance and extend the life of markings and stripes by removing a very fine layer from the top of the existing markings and stripes. In addition, it can be used to remove temporary road markings and stripes. The dry ice consumption was about 150 lbs per hour using the pneumatic system. At this rate, if cleaning could be accomplished in one pass, CO₂ cleaning would be cost-effective as compared to burning or grinding markings and stripes.

Tomco is working with the Georgia Department of Transportation to develop a CO₂ cleaning system to clean at least at a speed of 5 miles per hour. To do this, the feed mechanism and nozzle needs to be improved. Further field testing is also needed in order to develop a commercially feasible system.

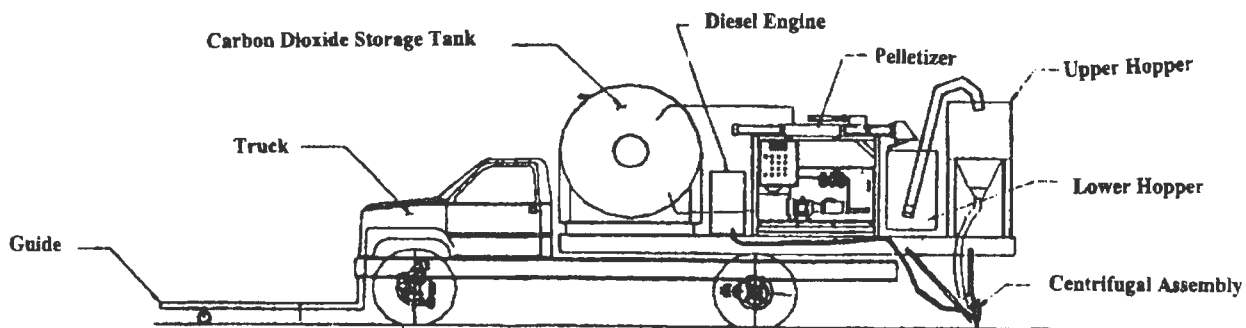

Figure 1

Drawing of proposed centrifugal transport.

DEVELOPMENT OF LED LIGHT SOURCE FOR TRAFFIC CONTROL DEVICES

NCHRP-IDEA Project 21

Mark Finkle [Tel: (814) 355-4479, Fax: (814) 355-5817],
The Last Resource, Inc., Bellefonte, Pennsylvania

This project produced a multi-use light-emitting device with delineation and warning capabilities based on light-emitting diode (LED) technology (Figure 1). The LEDs have a much longer life span than conventional lamps and require less power to operate. The internal light source can be placed in different types of housings that would allow the device to be used as a delineator, raised pavement marker, or steady-burn/flashing warning light. The result is a device that requires less maintenance and is more flexible in its use. The development of a prototype traffic control device (TCD) involved design and construction of the internal hardware for the LED light source and different types of housing required for the TCD system. Results based on accelerated testing show that the LED light source concept works as expected and produces significant gains over conventional light sources (Figure 2). The system now needs to be tested by state highway agencies.

The commercialization of the IDEA product is being explored. Various TCD manufacturers are being contacted. Because the light source and power controller are separate modules, that application of the active power management may be more attractive to manufacturers than the complete product. The final report is available from the National Technical Information Service (NTIS # PB97-143846).

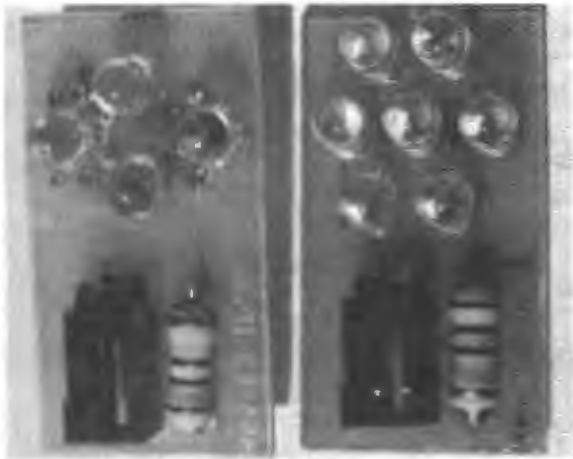

Figure 1

High- and low-intensity LED devices.

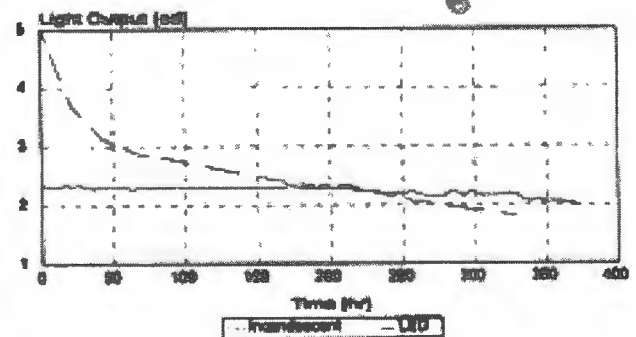

Figure 2

Results of endurance testing.

USE OF PHASE CHANGE MATERIALS TO PREVENT OVERNIGHT FREEZING OF BRIDGE DECKS

NCHRP-IDEA Project 22

Ival Salyer [Tel: (543)229-2654, Fax: (543) 229-4251],

University of Dayton Research Institute, Dayton, Ohio

This project evaluated a class of polymeric materials (linear crystalline alkyl hydrocarbons) that stored and released heat energy as a result of phase change in freezing temperatures for use in concrete to prevent overnight freezing of bridge decks. The phase change materials were encapsulated in high density polyethylene pellets and either mixed with or installed around concrete to provide heat energy. Modeling verification of the thermal response of bridges and roads under varying climatic conditions and with various phase change materials and application methods was performed. This was followed by laboratory tests and limited field evaluation to establish material performance and effectiveness in the highway freeze-thaw environment.

The test results show that the addition of phase change materials to the concrete prevented freezing on the surface (Figure 1). However, the addition of the materials also decreased the conductivity of concrete slabs, which slowed its warming and also adversely affected the performance of phase change materials. Placing the material at the bottom of the concrete slab delayed the cooling of the slab top surface. It also slowed its warming, which was not desirable. Darkening the top surface had a beneficial effect on the slab surface temperature. The final report is available from the National Technical Information Service (NTIS # PB97-143820).

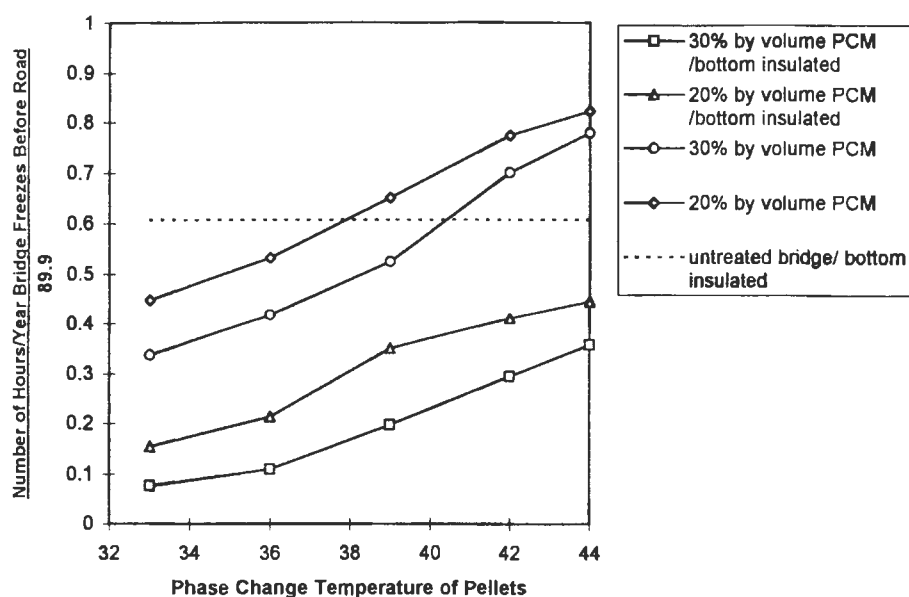

Figure 1

Hazard reduction as affected by phase change temperature for an 8-inch-thick deck with phase change material pellets in the top half.

LEAD-BASED PAINT REMOVAL FROM STEEL STRUCTURES

NCHRP-IDEA Project 23

Rudolf Keller [Tel: (412) 325-3260, Fax: (412) 335-8402],
EMEC Consultants, Export, Pennsylvania

This project evaluated an electrochemical cathode debonding process for stripping paint from highway steel structures (Figure 1). The method eliminates airborne paint particles and is a viable alternative to the common abrasive blasting of lead-based paint. In addition, toxic lead components can be collected and recycled. Laboratory tests were carried out to determine concept feasibility and optimize process parameters. The process effectively debonded and removed paint from steel surfaces in 1 to 2 hours using 10-cm x 10-cm electrolytic patches under a constant voltage of 8 to 12 V and a current of 7.5 A or less. A prototype paint removal equipment system was designed for larger-scale testing.

After additional process optimization in the laboratory, small-scale field tests on highway bridges and steel structures were performed to establish the application's feasibility in actual highway structures (Figure 2). The field work shows promising results. Some initial surface preparation may be necessary to initiate the process. A supplemental IDEA award was approved for full-scale field demonstration of the technology on highway bridges in collaboration with the Virginia Department of Transportation (NCHRP-IDEA #38). The final report is available from the National Technical Information Service (NTIS # PB97-141980).

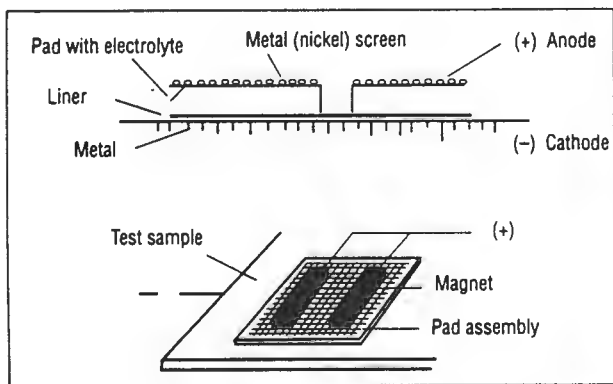

Figure 1

"Electric blanket" used for electrochemically assisted paint removal.



Figure 2

Field testing of process at bridge in Pennsylvania.

FIBER-OPTIC STRAIN SENSOR SYSTEM FOR LONG-TERM MONITORING OF HIGHWAY STRUCTURES

NCHRP-IDEA Project 24

Ken Lou [Tel: (602) 730-4446, Fax: (602) 893-8643],
Simula Government Products, Inc., Phoenix, Arizona

The project investigated the feasibility of a fiber-optic (FO) strain sensor system for long-term monitoring of highway structures. The principle of operation relies upon measuring the time-of-flight of an optical signal's propagation through an optical fiber and then converting it to mechanical strain. By segmenting an optical fiber string with optical reflectors, the strain of in-line segments can be determined separately. This method enables strain mapping of an entire structure with a finite-element sensor grid and is capable of detecting localized damage such as cracking and stress corrosion. The monitoring system includes a high-resolution optical time domain reflectometer (OTDR), FO data acquisition (FODAC) software, and FO strain gauge patches (FOSGPs), which allow monitoring of integral strain in large structures (Figure 1). The FOSGPs are flexible sensor patches that can be embedded in or attached to the structure to be monitored.

Tests with steel and composite coupons showed that, using the latest OTDR, the FOSGP sensors achieved a resolution of 0.01 percent strain and could resolve tensile strain in reinforced concrete just before failure due to fracture.

The sensitivity of the FOSGP sensor appears to be limited by the OTDR system. Also, the potential to multiplex patches in-line (to interrogate multiple locations) was limited because of increased attenuation of the FO sensors by the glass-reinforced epoxy carrier material. For the time delay strain measurements to be practical for structural monitoring, OTDR accuracy must be improved to at least better than 3.0 ps. The smaller 3-m patches may be multiplexed, but would require an OTDR with a resolution of better than 1.0 ps. The sensors appear to be most successful at detecting strain if placed at compression locations on concrete structures. Because of the limitations of the current OTDR system in achieving accurate measurements and the limitations of the type of optical fiber used in the concrete environment, no field demonstrations were conducted. The final report is available from the National Technical Information Service (NTIS #PB 98-139074).

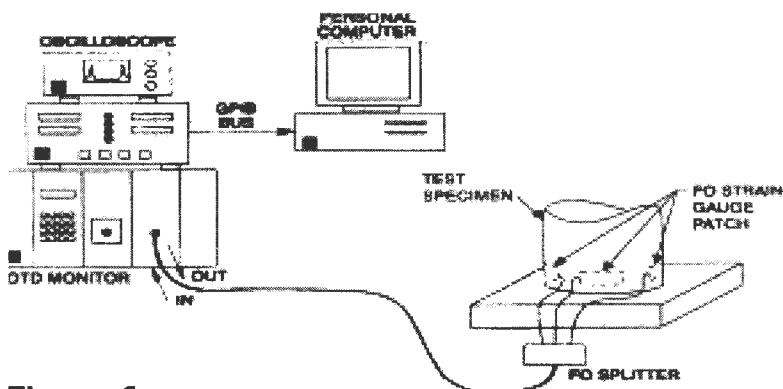

Figure 1

Fiber-optic sensor data acquisition system.

BASALT FIBER COMPOSITE REINFORCEMENT FOR CONCRETE

NCHRP-IDEA Project 25

V.B. Brik [Tel: (608) 244-1349, Fax: (608) 244-9071],
Research and Technology, Inc., Madison, Wisconsin

This project explored the feasibility of using rebars made from braided basalt fiber strands as concrete reinforcement (Figure 1). The material is expected to be a low-cost, high-strength, high-modulus, and corrosion-resistant alternative to steel for concrete reinforcement. The basalt fibers were produced using a process developed in Ukraine. Several types of basalt fibers were procured from Ukraine and evaluated for strength, brittleness, and tensile properties. A continuous basalt fiber, 9 to 15 mm in diameter, was determined to be most suitable for rebar fabrication. The rebars, consisting of about 80% to 90% fibers and an organic binder, were fabricated and tested for mechanical properties (strength and modulus) and corrosion resistance. Test results established the suitability of basalt composite rebars for use as concrete reinforcement (Table 1).

A supplemental IDEA award for large-scale and field operational testing of basalt rebars as concrete reinforcement was approved (NCHRP-IDEA 45). The final report is available from the National Technical Information Service (NTIS # PB97-161335).

TABLE 1. Mechanical Test Data for Epoxy-Bonded Basalt Fiber Composite Specimens.

Specimen No.	Width (mm)	Thickness (mm)	Failure Load (pounds)	Ultimate Strength (psi)	Elastic Modulus (msi)	Poisson's Ratio
1	25.0	3.3	10,340	83,738	4.52	0.128
2	25.0	3.3	10,340	83,738	4.52	0.128
3	24.8	3.1	10,512	37,745	5.40	0.205
4	24.8	3.2	10,040	81,558	4.61	0.210
5	25.0	3.3	10,368	83,952	4.98	0.177



Figure 1

Basalt fiber composite rebars.

CONSERVATION CONTROL LOAD SWITCH OPERATIONAL TESTS

NCHRP-IDEA Project 26

Greg Filbrun [Tel: (614) 895-1212, Fax: (614) 895-1213], CLS, Inc., Westerville, Ohio

This is a follow-on project for a previous IDEA project (NCHRP-IDEA Project 8) to perform field operational testing of an improved conservation traffic control load switch system. This microprocessor-controlled switch system extends the life of incandescent traffic lamps by reducing the initial current surge in the filament coil. About 100 units were assembled and provided to highway agencies for evaluation. Based on the users' feedback, the switch housing design was modified. The Institute of Transportation Engineers (ITE) and the National Electrical Manufacturers Association (NEMA) specifications were met and NEMA certification of conformance for the switch system was completed. The device is mechanically compatible with NEMA model 200 cabinets and, with minor housing adjustment, also with 170 signal cabinets.

Figure 1 compares historical and expected lamp maintenance expenditures for a standard three-lamp signal head and a three-lamp signal head using the IDEA product. The product is being evaluated in a pooled-fund study by a number of states. The final report is available through the National Technical Information Service (NTIS # PB97-143853).

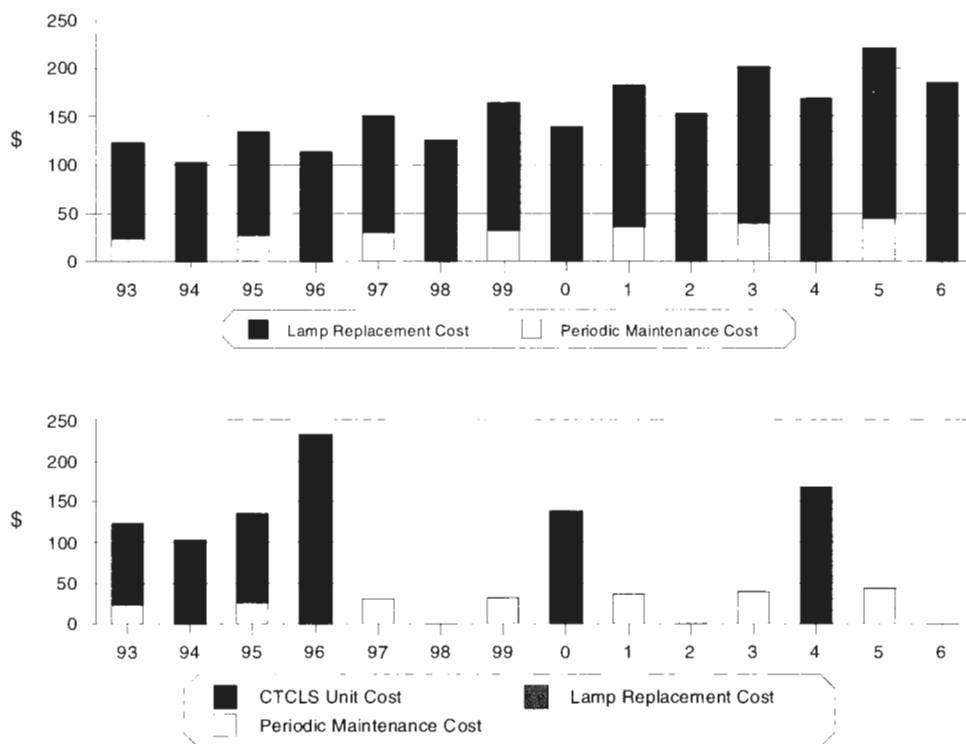

Figure 1

Historical and expected lamp maintenance expenditures. Top: Standard three-lamp signal head. Bottom: Three-lamp signal head using the IDEA product.

AUTOMATED BRIDGE DECK ANTI- AND DEICING SYSTEM

NCHRP-IDEA Project 27

Rand Decker, University of Utah, Salt Lake City, Utah

This project developed and tested an automated bridge deck anti- and deicing system. The system uses accepted deicing liquids, such as sodium or magnesium chloride, and traditional spray application techniques coupled with a modern roadway weather information system (RWIS) and novel data communication and process control to perform the task. Fixed snow and ice control systems are used in Western Europe to spray bridges with liquid snow and ice control materials. This system improves European practices and adapts them to U.S. highway practice. The innovative element of the system includes the provision for automated process control. The decision to apply anti- and deicing fluid to the bridge can be controlled by a knowledge-based algorithm (Figure 1), initialized on a process control computer located at the bridge. The process control algorithm uses data from the sensors of a modern RWIS. In addition, system status checks and manual operations may be carried out remotely using a cellular phone and voice/keypad menu commands. The anti- and deicing process can be initiated from the cab of a vehicle located at the bridge.

A prototype automated bridge anti-icing system was designed for and installed at the 6200 South Street overpass of I-215 in suburban Salt Lake City, Utah. The American Public Works Association, the British Ministry of Highways, the Kansas City Department of Public Works, the Japan Ministry of Construction, the Nevada Department of Transportation, and the Priority Technologies Project Office of FHWA have shown interest in using the system for road applications. The final report is available from the National Technical Information Service (NTIS # PB99-130718).

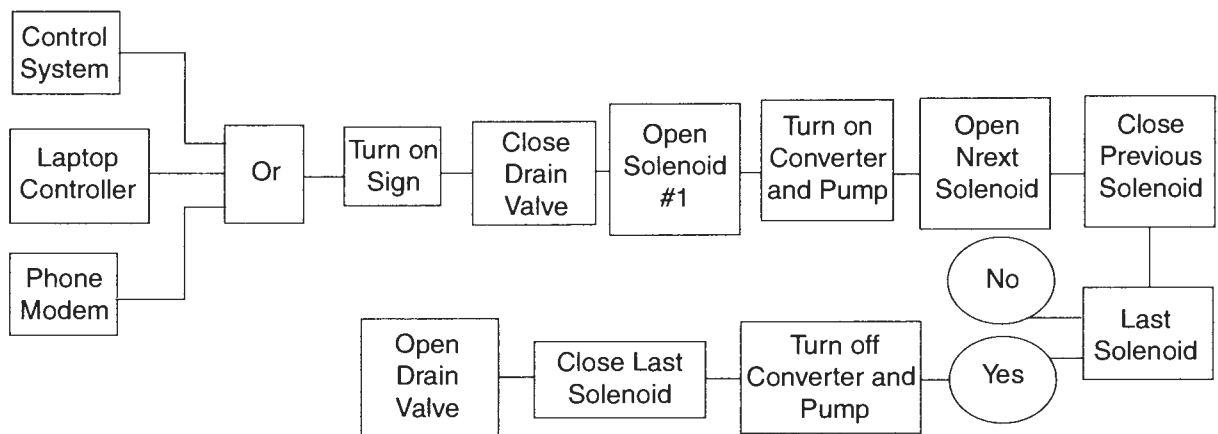

Figure 1

Spray system controller flowchart.

CORROSION-RESISTANT LOW-CARBON STEELS FOR CONCRETE REINFORCEMENT

NCHRP-IDEA Project 28

Gareth Thomas [Tel: (510) 486-5696, Fax: (510) 653-0965], and David Trejo,
University of California, Berkeley, California

This project designed and produced dual-phase ferritic martensitic (DFM) reinforcing steel with improved mechanical properties and corrosion resistance. DFM steel is a low-alloy, low-carbon steel produced by simply quenching the alloy from the two-phase ferrite/austenite field, thus producing a mixture of ferrite and martensite. The major strength source in the DFM structure originates from the presence of the inherently strong martensite phase, which provides the load-carrying constituent of the alloy. The soft ferrite phase provides the alloy with ductility.

Electrochemical evaluations were performed for in situ and ex situ conditions. The ex situ electrochemical test results provided different conclusions on the performance of the reinforcing steels. Anodically polarizing the steels in a de-aerated, decanted cement solution with 3.5% NaCl indicated that the DFM steel is more resistant to corrosion (Figure 1), while the ASTM A615 steel shows substantial corrosion products from the exposure. ASTM G-61 results indicate that the DFM steel is more susceptible to chloride-induced localized corrosion in the decanted, de-aerated cement solution. The ASTM G-61 results did not correlate with the in situ testing results and further investigations are required to determine these discrepancies.

In situ testing included Lollipop mass loss testing, Southern Exposure macrocell current testing, and Southern Exposure mass loss testing. All in situ tests indicated that the DFM reinforcing steel was more resistant to chloride-induced corrosion when embedded in concrete than commercially available reinforcing steels. The investigator is negotiating with Nucor Steel, a steel manufacturer, for production of a 50-ton heat of DFM steel. Since Nucor Steel does not have an on-line quenching, the steels must be heat treated following rolling. Bars from Nucor will be tested for mechanical and conversion properties. The final report is available from National Technical Information Service (NTIS #PB-139060).



Figure 1

ASTM A615 and DFM steels after ex situ imposed polarization testing.

SUPERELASTICITY-BASED MATERIALS FOR BRIDGE REHABILITATION

NCHRP-IDEA Project 29

Jer-Wen Hsu and Ken Ostowari [Tel: (517) 349-5653, Fax: (517) 349-5653],

DPD, Inc., Lansing, Michigan

Parviz Souroushian, Michigan State University, East Lansing, Michigan

The project developed and demonstrated the application of superelastic shape-memory alloys for the rehabilitation of bridge structures. These materials undergo phase transformation under stress and, after an apparent plastic deformation, return to their original shape when heated (Figure 1). A nickel-titanium-chromium alloy was selected and optimized based on strength and elongation capacity requirements. Structural design procedures for rehabilitation based on superelastic post-tensioning systems as well as rehabilitation schemes using shape-memory and superelastic alloys were developed. Results of tests on concrete beams demonstrated the effectiveness of rehabilitation by shape-memory reinforcement in eliminating excess deformations and crack widths after failure. The beams satisfied all the serviceability and strength requirements under twice the original live load after they were repaired. Work on using superelastic (in place of shape memory) reinforcement for rehabilitation showed that the superelastic reinforcement was able to recover up to 8% strain, which is estimated to be adequate for self-repair after substantial cracking and deformation. The superelastic reinforcement system was also processed into polymer matrix composite sheets and glued onto concrete structures for rehabilitation and self-repair. Testing verified applicability of the composite system to the self-rehabilitation technology. Large-scale demonstration of the rehabilitation technology in collaboration with the Michigan DOT is being performed in a follow-up IDEA project. The final report is available from the National Technical Information Service (NTIS #PB98-13508).

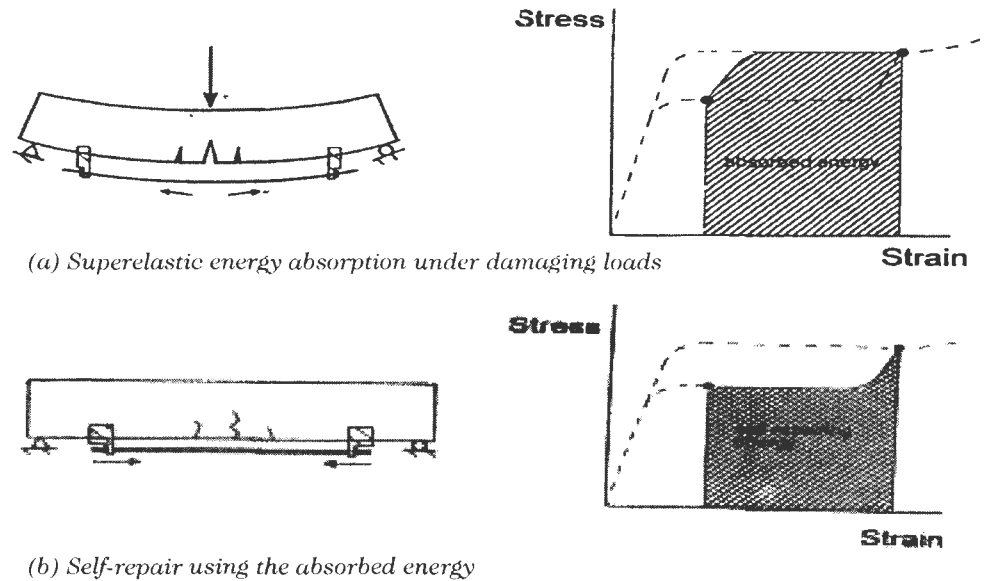

Figure 1

Schematics of the superelasticity-based post-tensioning system.

RAPID REPLACEMENT COMPOSITE BRIDGE NO. 1

NCHRP-IDEA Project 30

Jerry D. Plunkett [Tel: (913) 483-2589, Fax: (913) 483-5321],
Kansas Structural Composites, Inc., Russell, Kansas

This project designed, fabricated, and tested a lightweight composite bridge made of fiberglass-reinforced polymer honeycomb structural panels. The composite bridge was designed in accordance with U.S. Highway Bridge Code HS-25. The key strength requirement was that the span to deflection ratio be 750 under a 40,000-pound load. The bridge was constructed over No-Name Creek in Russell County, Kansas, using three fiberglass honeycomb panels with interlocking edges. Each panel was about 23 feet long and 9 feet wide. The bridge installation time was less than 6 hours. The bridge performance was tested by driving heavy vehicles onto the bridge panels and measuring the deflections (Figure 1). The performance measurements were within the bridge code requirements. The bridge is now open to traffic. A ribbon-cutting ceremony was performed in December 1996. A supplemental award (NCHRP-IDEA Project 46) has been made for preparing specifications and guidelines for installing the composite bridge and field evaluating the honeycomb panels in bridge decks on highway bridges in Kansas in coalition with the Kansas Department of Transportation. The final report is available through the National Technical Information Service (NTIS # PB97-201511).



Figure 1

Composite bridge under test in Russell, Kansas.

COST-EFFECTIVE MICROWAVE SENSOR TO DETECT HIGHWAY ROAD CONDITIONS

NCHRP-IDEA Project 31

Robert Kubichek [Tel: (307) 776-3182, Fax: (307) 766-4444], and
Suzanne Yoakum-Stover, University of Wyoming, Laramie, Wyoming

This project developed a method using active microwave sensing technique to measure moisture, snow and ice accumulation on rural highways (Figure 1). The system uses a low-power microwave transmitter and incorporates neural network and pattern recognition techniques for assessing road surface conditions. The basic system was designed, built and after laboratory testing, was installed at an outdoor location to collect data. Pattern recognition techniques were applied to the data to identify road conditions based on microwave signatures, and yielded 80-90% accuracy in detecting ice, snow, wet and dry road conditions. The classifier's accuracy was improved to over 95% by using a neural network technique. Several configuration modifications were made to the system to improve its performance. Field test of the system were conducted in cooperation with the Wyoming DOT during the 1997-98 winter season. Several companies have expressed interest in collaborating in commercializing the technology. However, additional design optimization and field tests are need to implement this technology. The project has received media attention through regional newspaper articles, TV and radio segments, and also has been described in journal articles including the October 1997 issue of *Popular Science*. The final report is available from the National Technical Information Service (NTIS # PB98-141187).

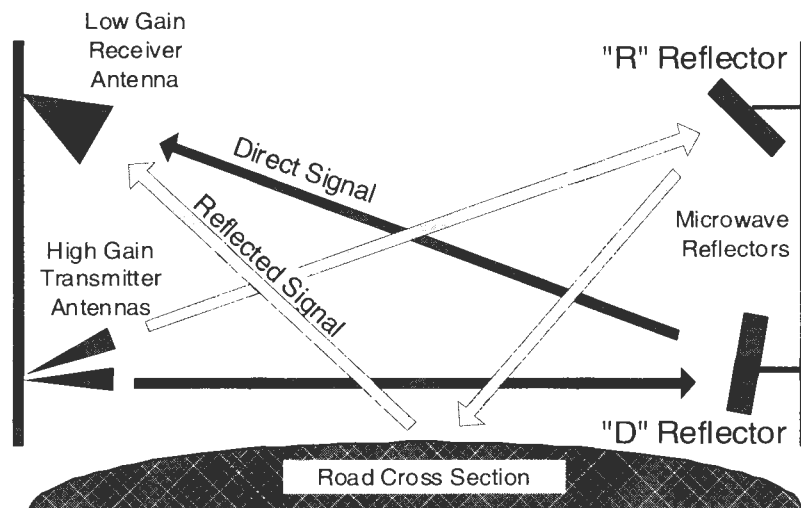

Figure 1

Antenna and reflector geometry, showing reflected and direct paths. Shown is the 10-GHz system; an identical 2-GHz system is implemented using dish antennas.

TESTING AND TRIAL DEPLOYMENT OF A COST-EFFECTIVE AND REAL-TIME ASPHALT PAVEMENT QUALITY INDICATOR SYSTEM

NCHRP-IDEA Project 32

Harry Apkarian [Tel: (518) 370-5558, Fax: (518) 370-5538], Raymond J. Piascik, and Frank S. Ralbovsky, TransTech Systems, Inc., Latham, New York

The project designed and tested a low-cost pavement quality indicator based on capacitance energy dissipation to measure density of asphalt pavements as a rapid, convenient, and safe alternative to nuclear gauge. A prototype system was designed (Figure 1) and tested on calibrated hot-mix asphalt cores of various thicknesses as well as on a variable-density stack of thin glass plates separated by measured air gaps to verify the system's accuracy, repeatability, temperature stability, sensitivity, and time stability. Also, the effects of various probe configurations and carrier frequencies were investigated. The prototype was subjected to preliminary field tests, and modifications of the system were made that included fine-tuning of the electrical circuit. Three prototype units were fabricated for field evaluation. The field test results were carried out at six sites in Nevada, New York, and Indiana. The field results showed that the instrument measures to a 2.5-in. depth at a speed of about 5 seconds per reading with good accuracy and reproducibility. The field performance was unaffected by temperature and moisture variations. The probe and the sensor circuit were redesigned to improve their accuracy. A market research study was conducted to determine the competition and demand for the IDEA product. The final report is available from the National Technical Information Service (NTIS #PB97-201503).



Figure 1

Advanced prototype of TransTech System's pavement quality indicator.

EVALUATION OF A NEW REHABILITATION TECHNOLOGY FOR BRIDGE PIERS WITH COMPOSITE MATERIALS

NCHRP-IDEA Project 33

Roberto Lopez-Anido, Rakesh Gupta,
Hota V.S. GangaRao [Tel: (304) 293-7608, Fax: (304) 293-7609],
Udaya B. Halabe, Sachin Kshirsagar, and Reynold Franklin,
West Virginia University, Morgantown, West Virginia

This project evaluated a bridge rehabilitation technology using glass fiber-reinforced fabric encasing on deteriorated bridge columns and piers. Laboratory test results showed significant increase in compressive strengths of concrete cylinders with composite wraps. The composite bond integrity under various environmental conditions was also established. The composite fabric rehabilitation technology was field tested in collaboration with the West Virginia DOT on Pond Creek Road bridge in Wood County, West Virginia. Three columns of the bridge were hand-wrapped with composite fabric (Figure 1), and three additional columns with composite shells. The repaired columns are being monitored for durability and bond integrity. Results to-date show excellent performance. The final report is available from the National Technical Information Service (NTIS # PB2000-103402).



Application of fiber composite wrap on Pond Creek Bridge.



Pier concrete column after wrapping.

Figure 1

Field installation of the composite wrap rehabilitation technology.

HIGHWAY GUARDRAIL INFRASTRUCTURE: SAFER TERMINAL DESIGNS

NCHRP-IDEA Project 34

James F. Wilson [Tel: (919) 660-5194, Fax: (919) 660-5219], Duke University, Durham, North Carolina

This project developed a unique class of guardrail terminal retrofits suitable for secondary roads (Figure 1). These new terminal structures do not penetrate errant vehicles but bend upon impact and form sufficient frontal area to mitigate vehicle spearing. Made of mild steel, these terminals curve away from the direction of traffic flow, have variable depth corrugations, have an increasing flare toward the impact end, and have breakaway supporting posts. Low-speed crash tests were performed on half-scale terminal models in which the test car, traveling at about 5 mph and without bumper shock absorbers, impacted the models head-on. These results showed that the plastic failure zones occurred further toward the tip of impact than for static loading, or at about the two-thirds point from the fixed end.

The ideal final design of a guardrail will incorporate the following features.

- A retrofit that is low cost, simply fabricated, and easily installed.
- A retrofit that buckles plastically near mid-length.
- A retrofit that helps redirect impacting vehicles and minimizes fatalities for their occupants.
- A retrofit that limits the ridedown deceleration of the impacting vehicle to 15 g.

The principal investigator, with Duke University's Office of Science and Technology, is processing a patent on this product and is looking for potential product developers who would be granted a license to manufacture and commercialize the product. The final report is available from the National Technical Information Service (NTIS #PB 98-139058).

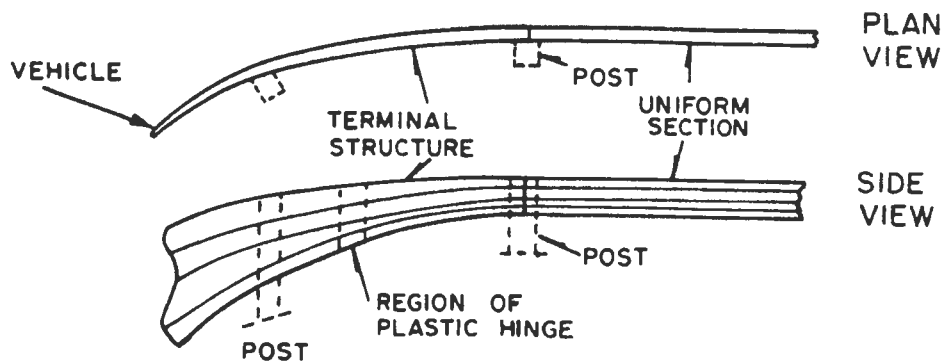

Figure 1

A terminal structure concept designed to avoid vehicle spearing.

IN-SERVICE REPAIR OF HIGHWAY BRIDGES AND PAVEMENTS BY INTERNAL TIME RELEASE OF REPAIR CHEMICALS

NCHRP-IDEA Project 37

Carolyn Dry [Tel: (217) 333-1913, Fax: (217) 244-2204],

Illinois Universities Transportation Research Consortium, Chicago, Illinois

This project evaluated the concept of self-repairing concrete containing fibers filled with adhesives (Figure 1) in large-scale laboratory and field tests. Four specific applications for this concept were explored in the laboratory and field experiments. In frames in the laboratory, it was shown that adhesive release from ruptured fibers helped distribute stress over the entire structure. In four full-scale bridge decks, the adhesive filled tubes were put near the surface to function as creators of automatically fillable control joints. Surface shrinkage cracking acted to pull the brittle tubes apart and the sealant/adhesive flowed to fill the cracks. In another application, the adhesive-filled tubes were placed in the body of the deck to break due to shear cracking and repair these cracks. This type of release not only strengthened the decks but also distributed the stress to other locations. In the final application, large beams containing adhesive-filled tubes were tested to failure. The results showed added strength due to release of adhesives. The study also established the survival of adhesive-filled tubes during mixing in the concrete mixer, maintenance of the liquid phase of the adhesive, ease of finishing the concrete containing adhesive-filled fibers. Long-term field evaluation of bridge decks and pavements in a highway environment is needed to implement the rehabilitation technology.

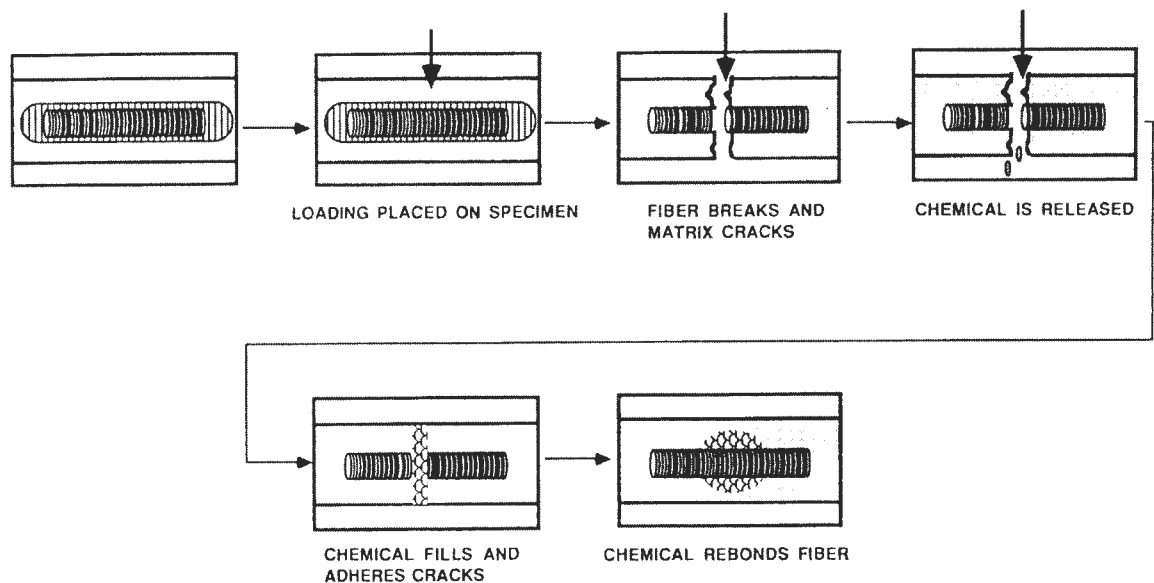

Figure 1

Concept of in situ self-repair of concrete by adhesives in embedded hollow fibers.

PAINT REMOVAL FROM STEEL STRUCTURES: TESTING AND DEMONSTRATION OF ELECTROSTRIP™ PROCESS

NCHRP-IDEA Project 38

Rudolf Keller [Tel: (724) 335-2666, Fax: (724) 335-8402] and Brian J. Barca,
EMEC Consultants, Export and New Kensington, Pennsylvania

This follow-on IDEA project demonstrated the field application of an electrochemical paint removal process, developed in an earlier IDEA project (NCHRP-IDEA 23). Equipment components to treat up to 50 ft² in one application were acquired and preliminary field tests were performed in Pennsylvania and Virginia. Based on test results, supplies and equipment were selected for a full-scale field demonstration to remove paint from an area of 800 ft² at the I-66 Westmoreland Street overpass in Arlington, Virginia. The field demonstration was successfully carried out in May 1998, in collaboration with Virginia DOT (Figure 1). A showcase event, highlighting the IDEA technology and organized by the Virginia DOT, preceded the field demonstration. The test was completed ahead of schedule, and results were consistent with the targeted removal rate of 40 ft² per hour. Prior to the field demonstration, tests were performed to monitor environmental and occupational exposure. The exposure of personnel was well below the specified OSHA level for particulates and no changes were detected in soil samples.

Cost projections indicate a competitive price of \$7 to \$10 per ft² for full paint removal and repainting and are comparable to quoted average costs for traditional abrasive blasting. However, full commercial implementation will require scale-up equipment and additional process optimization. Additional process demonstrations will also be needed on a non- or near-competitive basis. The final report is available from the National Technical Information Service (NTIS # PB99-117087).



Figure 1

Treated area after initial cleaning.

ESTIMATING TRUCK ATTRIBUTES FROM BRIDGE STRAIN DATA USING NEURAL NETWORKS

NCHRP-IDEA Project 40

Ian Flood [Tel: (352) 392-7287, Fax: (352) 392-9606, University of Florida, Gainesville, Florida

This project developed a neural network-based method of estimating truck attributes (such as axle spacing and axle loads) from strain response of the bridge over which the truck is traveling. The research showed that this could be accomplished fairly accurately using a two-layered artificial neural network (Figure 1). In particular, the EHAM (an extended Hamming network) method provided results as reliable as RGIN (a radial-Gaussian network that uses incremental training algorithm) method for classifying trucks and outperformed RGIN in the speed with which it can develop a working model for the bridge. However, work on improving the classification accuracy (and thus ultimately the accuracy of estimates of truck attributes such as axle loads and spacing) by allowing a SORG (a self-organizing network) method to develop its own classification system for trucks were inconclusive. The project has generated interest from the industry, and an international consortium is exploring the possibility of adopting and implementing this technology. The final report is available from the National Technical Information Service (NTIS # PB2000-103400).

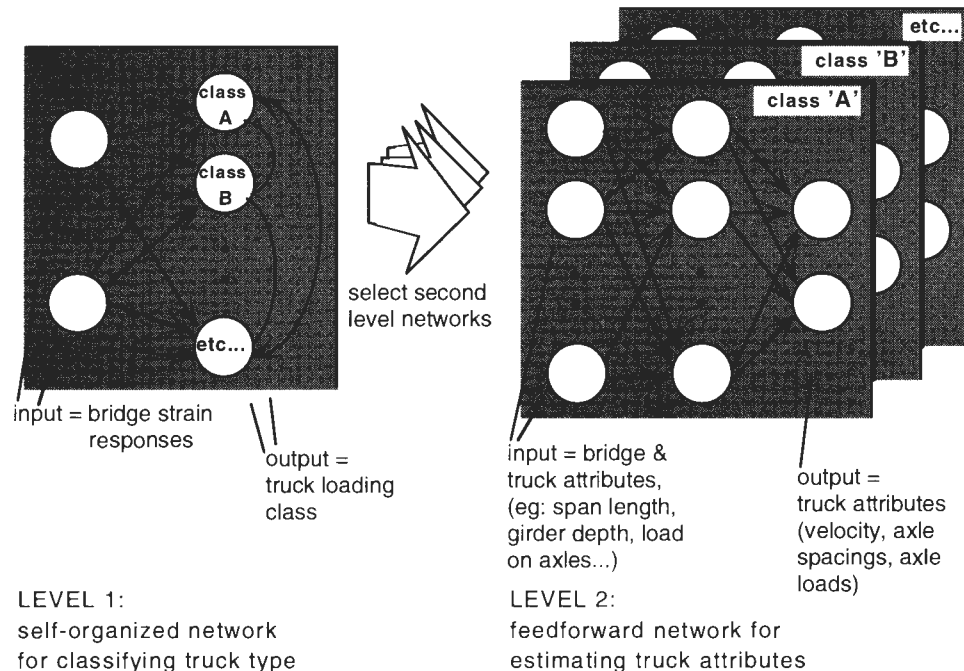

Figure 1

Architecture of Proposed Networking System

ROBOTIC SYSTEM FOR UNDERWATER BRIDGE INSPECTION AND SCOUR EVALUATION

NCHRP-IDEA Project 43

James DeVault [Tel: (913) 532-4594, Fax: (913) 532-1188],
Kansas State University, Manhattan, Kansas

The project investigated the feasibility of using a semiautonomous robotic system to position a sensor platform in close proximity to underwater bridge support structures while providing video or other sensory information to support evaluation and documentation of structural condition, including scour. The primary system consists of two or more identical mobile robots designed to travel along opposite surfaces of submerged structures while connected to one another by a cable and winch system (Figure 1). Each robot contacts the surface through cleated rubber tracks (or, alternatively, wheels and rubber tires) that are driven by internal motors. Tensioning the cables that connect the two robots provides traction. In response to an operator's command to move to a new position, the robot team automatically coordinates both movement and cable tension. A graphical user interface provides the operator status information and control options. This robotic system may be used to augment traditional diver inspections, thereby reducing diver time and cost and enhancing safety.

Two prototype systems were constructed and tested, and the findings applied to development of a third system of significantly different design. This system has a broad array of potential applications for inspection of submerged physical structures, such as bridge substructures, pipelines, water towers, industrial smokestacks, nuclear cooling towers, oil rigs, oil derricks, floating platform support structures, and docks.

The Kansas State University Research Foundation is pursuing patent protection for all aspects of this system. The Mid-America Commercialization Corporation is developing commercialization strategy for this technology. Initial estimates of the manufactured costs of the system range from \$25,000 to \$50,000. The final report is available from the National Technical Information Service (NTIS # PB99-130700).

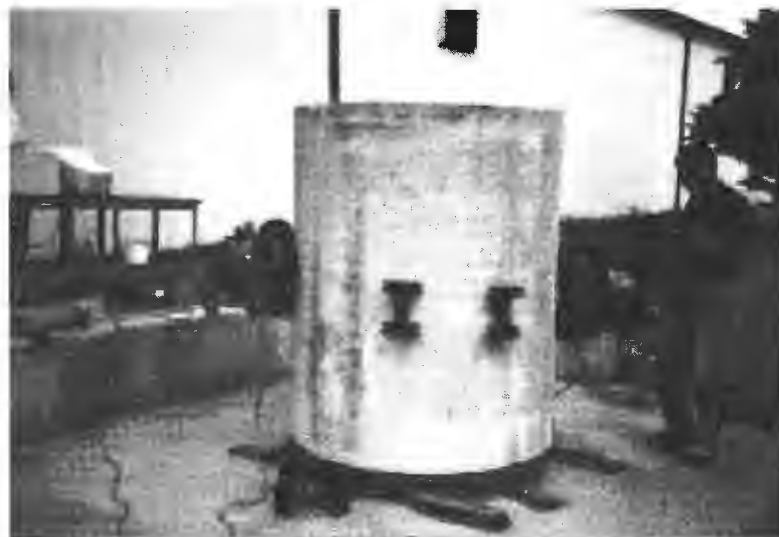

Figure 1

Two mobile robots connected to each other travel opposite sides of a structure to provide video and sensory information to remote users.

ROLLER-MOUNTABLE ASPHALT PAVEMENT QUALITY INDICATOR USING DIFFERENTIAL MICROWAVE SIGNALS

NCHRP-IDEA Project 44

Edward J. Jaselskis [Tel: (515) 294-5225, Fax: (515) 294-8000], Iowa State University, Ames, Iowa

This project developed a technique using microwave sensors installed on a pavement roller for real-time measurement of asphalt pavement density. Two microwave antennas, one in the front and the other at the back of a paving roller, measure microwave signals reflected from asphalt, and the difference between the signals is correlated with the degree of compaction of asphalt pavement (Figure 1). Following laboratory evaluation of the interaction of microwaves with asphalt, a prototype system was designed and field tested. The field tests verified a relationship between asphalt pavement density and microwave signal variance. The signal variance decreased with increasing asphalt density, but increased rather abruptly near the point of optimum compaction. These characteristics can be used to develop a non-contact method for a real-time assessment of the degree of compaction of asphalt pavements. However, additional system refinement and field evaluation are necessary to make this technology fully implementable. The final report is available from the National Technical Information Service (NTIS # PB2000-10340).



Figure 1

Prototype system for asphalt pavement density determination.

PERFORMANCE EVALUATION OF BASALT FIBERS AND COMPOSITE REBARS AS CONCRETE REINFORCEMENT

NCHRP-IDEA Project 45

Vladimir Brik [Tel: (608) 244-1349, Fax: (608) 244-9071],
Research and Technology, Inc., Madison, Wisconsin

V. Ramakrishnan, South Dakota School of Mines and Technology, Rapid City, South Dakota

This project evaluated the suitability of basalt fibers and basalt fiber composite rebars in concrete as an economical and durable alternative to reinforcing steel. Concrete specimens reinforced with basalt fiber composite rebars and basalt fibers (up to 2% by volume) were tested in accordance with ASTM standard test procedures. The basalt composite rebar exhibited tensile strength three times that of steel rebar. However, the mechanical performance of prestressed specimens was poor because of creep developed at the cement matrix-basalt composite interface. This limits its application for prestressed concrete reinforcement. Use of basalt fibers in fiber-reinforced concrete appears promising. Basalt fiber-reinforced concrete specimens showed a significant increase in toughness and impact strength (Figure 1) and a reduction in crack intensity and size as compared to plain concrete. The overall performance of basalt fibers in concrete was found to be similar to that of polypropylene fibers. Discussions are under way with the Wisconsin Department of Commerce for support from its Technology Development Fund to explore the use of locally available basalt mineral from northern Wisconsin and Minnesota for manufacturing basalt fibers and basalt fiber composite materials. The final report is available from the National Technical Information Service (NTIS # PB99-145104).

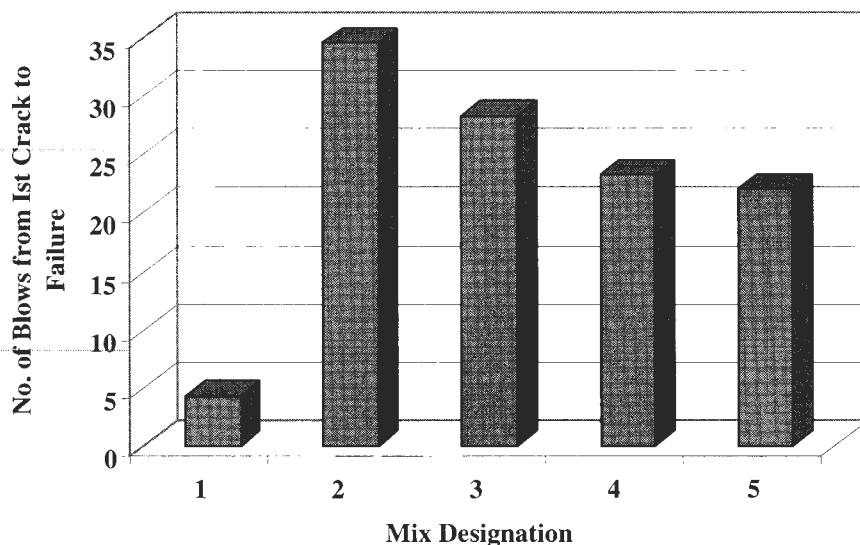

Figure 1

Toughness and impact test results for basalt fiber-reinforced concrete (Mix designations #1,2,3,4 and 5 correspond to basalt fiber contents of 0%, 0.5%, 0.4%,0.25% and 0.1% respectively).

PAVEMENT QUALITY INDICATOR: FIELD OPERATIONAL TESTING AND PRODUCT TRANSFER

NCHRP-IDEA Project 47

Harry Apkarian [Tel: (518) 370-5558, Fax: (518) 370-5538] and Peter Sawchuk,
TransTech Systems, Latham, New York

This is a follow-on project for field testing and implementation of a pavement quality indicator (PQI) system developed in a previous IDEA project (NCHRP-IDEA 32) for real-time asphalt pavement density measurements (Figure 1). The project was carried out in collaboration with the New York State Energy Research and Development Authority and the U.S. Army Corp of Engineers. The test program produced several design improvements that included sensing probe design, averaging capability of microprocessor logic, backlit readout screen, and calibration capability enhancement. Test results showed that the equipment performed equal to or better than the nuclear density gauge both in accuracy and reproducibility. The equipment is commercially available. More than 500 units have been sold both in the U.S. and abroad. The PQI system is currently being evaluated for field performance by a number of states in a pooled-fund study. The final report is available from the National Technical Information Service (NTIS # PB99-117095).

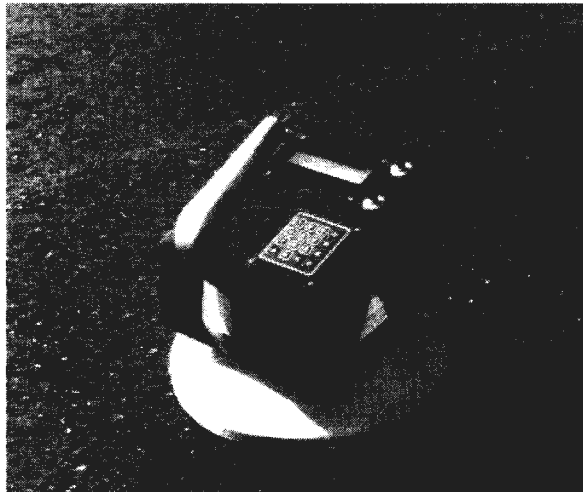

Figure 1

Pavement Quality Indicator Prototype

FIELD TRIAL OF SHAPE MEMORY-BASED REHABILITATION SYSTEM

NCHRP-IDEA Project 48

Ken Ostowari [Tel: 517-349-5653; Fax: 517-349-5653], DPD, Inc., Lansing, Michigan
Parviz Soroushian, Michigan State University, East Lansing, Michigan

This project demonstrated the application of superelastic shape memory alloys for the rehabilitation of bridge structure. Shape memory alloys recover deformations induced at lower temperatures upon heating above a transformation temperature; restraint of this shape recovery generates relatively large stresses. These stresses are used here to transfer corrective forces to structural systems for strengthening and repair effects. For this purpose, shape memory rods are pre-elongated, anchored to the structure, and subjected to electrical resistance heating to transfer corrective forces to the structure. The project used iron-based shape memory alloys of relatively low cost; the alloy composition was selected to yield relatively high and stable levels of restrained shape recovery stresses. Laboratory tests verified the ability of pre-elongated rods anchored onto damaged structural systems to restore structural integrity through application of corrective forces. Subsequent damaging effects could also be overcome by electrical resistance re-heating of rods.

A reinforced concrete bridge structure with beams lacking sufficient shear strength at longitudinal bar cut-off locations was selected for field demonstration of the technology. A design methodology was developed and verified through laboratory tests simulating conditions of the selected bridge structure. Subsequently, a detailed design was developed and the approach was successfully implemented under field conditions (Figure 1). The final report is available from the National Technical Information Service (NTIS # PB2000-105060).

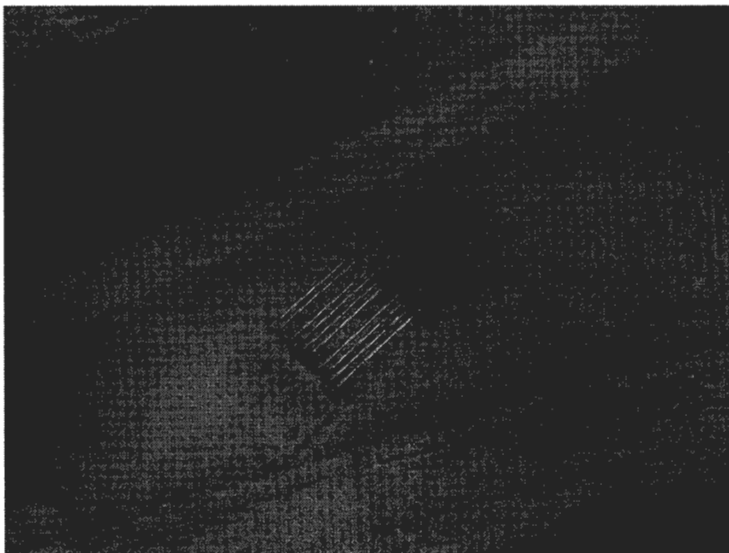

Figure 1

Field implementation of shape memory-based rehabilitation technology (final field set-up for application of local corrective forces)

DAMPER SYSTEMS FOR SUPPRESSION OF BRIDGE STAY CABLE VIBRATIONS

NCHRP-IDEA Project 50

Habib Tabatabai and Armin B. Mehrabi [Phone (847)965-7500, Fax (847)965-8997],
Construction Technology Laboratories, Inc., Skokie, Illinois

This project developed and evaluated damper systems for suppression of bridge stay cable vibrations. Three damping approaches—a tuned-mass damper (TMD), a liquid damper, and wrapping cable with damping tape were tested using various grout mixes and cable models. In addition, a concept based on cable guide pipe filled with polyurethane material was also evaluated. The latex grout improved damping by about 60 percent as compared to the conventional grout. Use of neoprene washers also improved the damping significantly. However, neither of these improvements was adequate to control rain-wind vibrations based on current criteria. Use of a damping tape on the outside surface of the cable produced no significant improvement. The results show the tuned-mass damper (TMD) system, which can be applied anywhere along the length of the cable, to be the most cost-effective temporary or long-term solution to the rain-wind vibration problem (Figure 1). A follow-on project for field evaluation and implementation of the technology has been approved by the NCIIRP-IDEA Project Committee. The final report is available from the National Technical Information Service (NTIS # PB2000-15409).

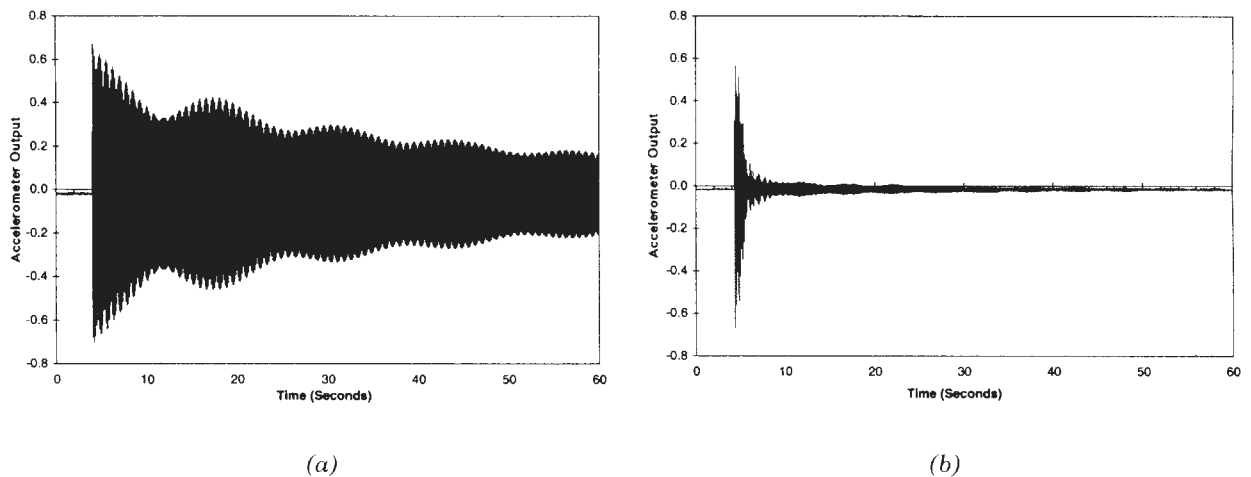

Figure 1

Comparison of cable responses, (a) without TMD; (b) with TMD

SECTION 2 ACTIVE IDEA PROJECTS

This section reports progress on all NCHRP-IDEA projects that were completed or active during the 2000 program year.

FIELD TESTING WITH THE DUOMORPH: A SELF-CONTAINED PORTABLE DEVICE FOR SHRP BINDER TESTING

NCHRP-IDEA Project 41

Samuel H. Carpenter [Phone (217) 333-4188 Fax: (217) 333-1924], University of Illinois, Urbana-Champaign, Illinois

IDEA Concept and Product

The Strategic Highway Research Program (SHRP) developed new testing protocols for the testing and grading of asphalt cements. The resulting specification represents the first time that fundamental testing of a rheological nature is used as an integral part of the specification and purchase process for asphalt binders. The equipment for this classification is expensive and limited to testing in a laboratory environment on materials with little particulate concentrations. The Duomorph is a piezoelectric sensor that can be embedded in a viscoelastic material and determine the modulus and phase angle of the material, the same data required for the Superpave binder grading. This device has potential to allow Superpave grading information to be obtained on asphalt materials at the plant. It can be used on materials as they are being blended to verify the properties without sampling and transporting back to the laboratory. This project evaluated the durability of the Duomorph and the capability to determine Superpave properties comparable to laboratory testing. The final product would be a device and supporting electronic equipment that would allow rapid determination of Superpave binder properties on a real-time basis as the materials were delivered or produced.

Project Results

The first phase of this project evaluated the durability of the Duomorph and assembled the necessary electronic equipment to operate the Duomorph and record the data. This equipment was assembled into the Duomorph Asphalt Rheology Tester (DART). The DART was found to be durable and possible of providing accurate determinations of the stiffness (G^*) over the range of temperatures of interest to binder grading (70 C to -24 C). Difficulties were encountered in determining the phase angle at higher temperatures in the range above 35 C. In the range of 35 C to 0 C the phase angle was comparable to that determined from the standard Dynamic Shear Rheometer (DSR). Testing was conducted on original binder, RTFOT aged binder, and PAV aged binder for these comparisons. Parametric studies of the duomorph physical properties (diameter, thickness, piezo material type) were conducted to verify the suitability of gage sizes required for testing liquid asphalt binders.

Phase 2 work was directed toward simplifying the data reduction process to provide an automated scheme, and at improving the analysis procedure to eliminate the phase angle measurement inaccuracy at elevated temperatures. Continued testing showed the accuracy of the DART to be as good and as repeatable as the DSR. Viscoelastic 3-D finite element modeling has been performed that reproduces the laboratory measurements and was used to produce a solution set for a wide variety of material properties. A genetic algorithm for a neural net analysis has been used to establish the relationship between gage deflection measurements and asphalt binder properties.

Work is continuing of refining the analytical scheme to provide for an automated data collection and data reduction capability. Without this capability, the scheme is too cumbersome to be used by a technician in the field as it requires use of separate computer programs and nomographs to extract the information. Discussions are underway with an equipment manufacturer to consolidate the electronic equipment into a small portable unit suitable for field use. The development of an analysis procedure will be completed in December 2000.

Payoff Product Potential

The duomorph assembly, termed DART, has the potential to provide a portable field device that can be used at a plant or refinery to verify the more extensive laboratory testing program used for material certification. The DART can be used on modified asphalts with particulate matter such as crumb rubber modified binders. It can be used at the plant to test asphalt that has been blended with a polymer to verify the blending process. It can be used on material sampled directly from a tanker to verify that the material is the same as what was specified. This ability to provide a rapid indication of product acceptability before use could result in significant savings by avoiding using materials that later are proven to be unacceptable. This use as a fingerprinting tool for monitoring material variability using the same material properties that are determined in the full grading acceptance scheme provides a unified process in a real-time format not previously possible.

Product Transfer

Discussions are underway on an informal manner with an equipment manufacturer to determine if the commercial potential is suitable for development of the electronic package. These discussions will continue.

DUAL-CORE FIBER OPTIC WIM SYSTEM

NCHRP-IDEA Project 42

Ramesh B. Malla [Tel. (860) 486-3683, Fax (860) 486-2298, and
Norman W. Garrick, University of Connecticut, Storrs, Connecticut

IDEA Concept and Product

The final product will be a sensor for weighing and counting highway vehicles. This weigh-in-motion (WIM) system will be used on roads that are functioning under normal conditions and will cause no disruption to traffic. The technological breakthrough behind this WIM sensor is a dual-core optical fiber that is radically different from most fibers that are currently being used in civil engineering and other sensing applications. The WIM system will be simpler to install and operate and more accurate than comparable devices.

Dual-core fiber has two concentric light guiding regions of different effective optical path length, which allows for measuring magnitude as well as positions of forces that are applied at multiple locations along a single fiber and using a single light source and photodetector. The WIM device will be configured to give not only vehicle weight and volume but also speed, inter-axle distance, and lateral vehicle location.

Project Results

In Phase I, the investigators designed and fabricated a prototype WIM system (Figure 1) and tested the system both with loading machines and with an actual vehicle. As a part of this process, the optical fibers used in the system were characterized and calibrated.

In the vehicle test, the prototype WIM was installed between wooden tracks that were used to simulate a pavement. The vehicle (a passenger car) was then driven over the system and the optical signal was recorded for various locations of the car wheel over the prototype WIM device (Figures 1 and 2).

The test results on the performance/characteristics of the batch of special FTDM fiber revealed some deviation from its theoretically expected behavior. Within this limitation, the laboratory test results of the prototype WIM device proved to be very promising. The load test showed a very good relationship between the magnitude of the applied load and the changes in the optical signal. Furthermore, the changes in the optical signal during testing with the car were quite similar to that obtained for the load machines. Figure 1 shows the car wheel testing in progress. Figure 2 shows the time delay of the output light pulses traveling through the fiber before and after the vehicle wheel load. This time delay allows the system to pinpoint the location of load application to a fair degree of accuracy. The intensity change in the signal before and after the load gives a good measure of the magnitude of the wheel load. Based on these results, the prototype shows potential for accurately determining the magnitude and location of vehicular loads. Toward the end of the project, an automated computer system to acquire and analyze the data from the prototype WIM sensor device was developed.

The test results have provided the information needed to improve the performance of the special fiber, configuration of the system, and in general to optimize the prototype in terms of size and performance. Although the funding from NCHRP-IDEA program for this project has expired, the research on this topic is continuing. The investigators are designing and building a second-generation prototype and conducting additional tests to fully characterize its performance. In addition, a dedicated optical system that will be rugged enough for field-testing is in development.

Product Payoff Potential

Highway deterioration accelerates exponentially as truck weight increases. Accurate data on vehicle weights are essential for the design and management of highway pavements. Currently, we do not have comprehensive data on the weight distribution of vehicles using our highways. Reliable, inexpensive and easy-to-use WIM would help to correct this problem resulting in improved highway design procedures. Each year over \$7 billion is spent on highway construction, rehabilitation and maintenance: improved WIM technology will help to save a significant fraction of this direct cost. The cost of traffic data collection process is also expected to decrease with the development of this product.

Product Transfer

The Connecticut Department of Transportation has been involved with the project from the beginning. The investigators anticipate that they will provide help and advice for the field-testing, and serve as beta testers for the prototype in the future. The Connecticut Department of Motor Vehicles has also shown interest in the possible outcome of the research work. The advisory panel for this project consisted of members with connection to user agencies (includ-

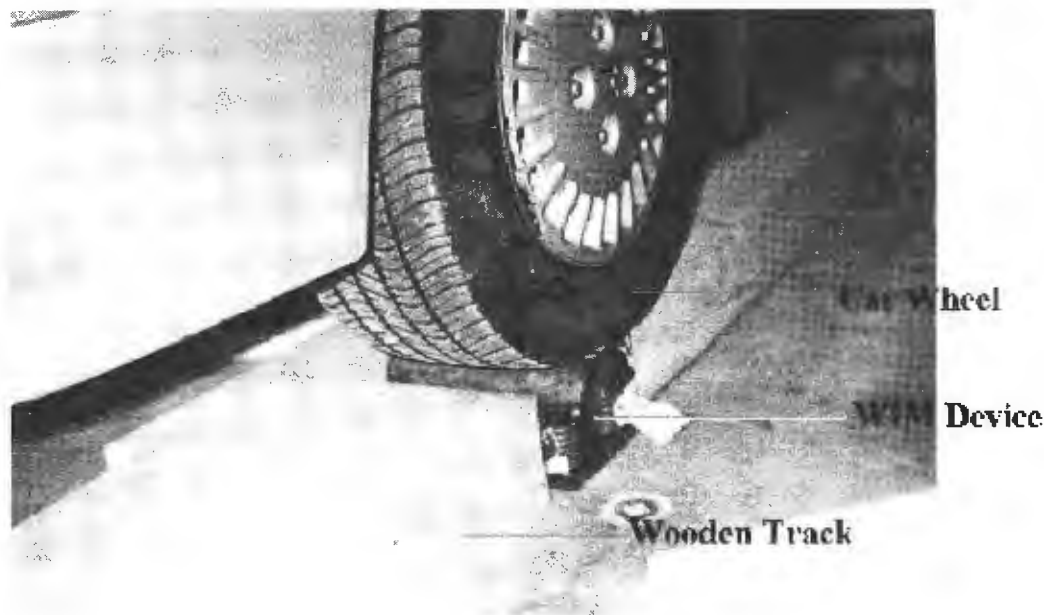

Figure 1

Car Wheel Testing in Progress

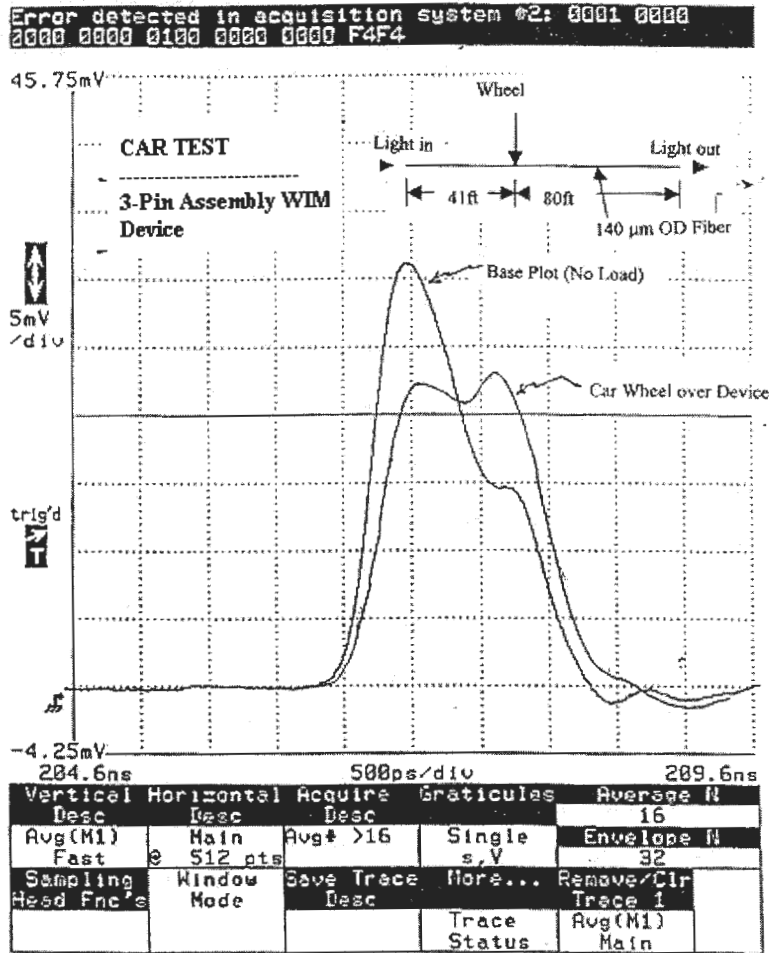

Figure 2
Oscilloscope traces from car test

ing FHWA) and industry. The industrial affiliate, MetriLight, Inc., is supporting this work by providing the optical fiber. MetriLight principals were the inventors of the fiber and hold the patent to this product. Results from the project were presented at seminars, symposia, workshops, and conferences (including the NSF/FHWA International Workshop on Fiber Optic Sensors for Construction, Materials and Bridges in May 1998) and have also been published.

FIBER-REINFORCED POLYMER HONEYCOMB SHORT-SPAN BRIDGE FOR RAPID INSTALLATION

NCHRP-IDEA Project 46

Jerry D. Plunkett, [Tel: (785) 483-2589, Fax: (785) 483-4535] and Stephen R. Gill, Kansas Structural Composites, Inc., Russell, Kansas

IDEA Concept and Product

The product system developed during this project consists of three items: 1) Fiber-reinforced polymer (FRP) bridge deck panels; 2) a saddle support system attached to steel beams that allows deck drainage even though all support beams are of equal elevation; and 3) an attachment system, the Kansas Connector, that holds the FRP deck panels securely in place. These three elements allow FRP panels to be used for a broad range of diverse applications.

Project Results

Two bridge decks were installed last October in Crawford County, Kansas on Route 126. These decks were 45' long by 32' wide. Each bridge deck was completely installed in one day. The installation was flawless and required less manpower and time than expected.

Bridge deck performance has been excellent and all specifications have been fully met. The two bridge decks were monitored and tested by the Civil Engineering Departments of the University of Kansas and the University of Missouri, Columbia.

The support saddle system makes it feasible to provide both drainage slopes and/or super-elevation on decks supported on beams that are all of equal elevation, or for other changes in deck lateral slope. Moreover, the final deck height can be adjusted to match existing road levels at abutments or expansion joints within 1/16" – 1/8", which minimizes the repaving work.

The attachment system is hidden within the panel joints and yet is easily available for future adjustments. The attachment of FRP structural materials to steel/concrete support beams requires careful design details. The Kansas Connector utilizes a design that recognizes and respects the low compression and shear strength of FRP materials and thus provides long-term stable connections.

Product Payoff Potential

Existing methods of rehabilitating bridge decks are time consuming and create long traffic delays. Using the system developed under this project, it will be feasible to rebuild bridge decks rapidly and to greatly reduce these traffic delays. Not only can individual traffic lanes be closed for complete and rapid rehabilitation; they can be closed for short periods of time during low traffic use for rehabilitation segment by segment. Thus traffic can be maintained during rush hours over heavily traveled commuter highways with minimal delay and disruption to the public.

The traveling public is increasingly sensitive to delays and congestion arising from bridge rehabilitation. A sizeable portion of this market will be open to FRP technology as motorists become aware of the availability of these new concepts and their many advantages. The potential market is several billion dollars per year.

The products developed under this project permit the removal and replacement of damaged bridge deck panels and the removal and re-use of bridge decks from bridges that are no longer in service or those to be upgraded. Bridges will no longer be torn down but can be removed and re-used easily and cheaply. Thus bridges using this technology will possess a large salvage/re-use value.

Product Transfer

The technology developed through this project is currently being used for two bridge decks in Missouri and one in West Virginia. Technical discussions are being conducted with six other states that are considering or planning on using this technology. In 2001, investigators expect that at least 10 bridge decks will be put in place on new or rehabilitated bridges.

AUTOMATION OF LEGENDS PAINTING

NCHRP-IDEA Project 49

Duc Huynh [Tel: (510)438-9714, Fax: (510) 438-0194],
Pavement Marking Technologies, Inc., Menlo Park, California

IDEA Concept and Product

This project develops and tests a mobile automatic legend painter. The system allows an operator to paint any legend from inside the cab of the truck faster than any other method currently available. The system is based on a unique patented control algorithm. In current form, the system is implemented with a multiaxis gantry system as shown in Figure 1. The system is specifically designed to take advantage of the next generation of marking material (track free in less than 3 minutes and 100% solid). The goal is to produce a fully automated system that can apply a legend and be open to service in 7 minutes or less.

Project Results

To date, several field surveys were conducted to obtain information from highway agencies, highway painting service organizations, and municipal legend painting service agencies on special requirements for pavement systems. Based on that information, design features of the RoadWriter™ were optimized.



Figure 1

Truck-mounted RoadWriter™ prototype system in field operation.

A full-scale robotic, fully automated system was designed and fabricated. The system was mounted to a cab-forward truck, lab tested and field-tested. A videotape was made showing the system painting the legend "STOP" at an intersection in less than 5 minutes.

A regional panel of experts consisting of representatives from academia, state agencies, local municipals, private contractors, consultants and bankers was convened to review and give specific recommendations on the prototype system. Most of the recommendations were incorporated into the redesigned RoadWriter™. Due to budget constraints, some recommendations were postponed until further funding can be secured. Nevertheless, investigators have been successful in developing and testing a mobile automatic legend painter. The system allows one operator to paint any legend from inside the cab of a truck faster than any other method currently available. Demonstrations have shown that the RoadWriter™ could improve cycle time, application quality and most important of all, safety.

Product Payoff Potential

Investigators calculate that the Roadwriter, compared to the conventional method, would pay for itself in 18 months time, assuming a \$300,000 purchase price. The savings comparison is even more dramatic when one considers all the other legends that must be installed each year. SCHOOL ZONE, SLOW, SCHOOL XING, ONLY, directional arrows, bicycle symbols, stopbars, etc. This estimate does not take into account the unquantifiable savings due to improved worker, driver, and pedestrian safety (fewer workers' comp claims, fewer injuries to drivers, passengers and pedestrians, and fewer damage claims for vehicles and other property. The selling price of the Roadwriter has not been established yet; \$300,000 is used in this analysis for the sake of conservatism.

Product Transfer

In its current form, the RoadWriter represents significant advancement in technologies for the pavement maintenance industry. It demonstrates that automation can be integrated in large scale for the rugged pavement maintenance industry. Although the system has achieved major accomplishments, it still has some technical challenges before it can be released as a commercial system. Pavement Marking Technologies, Inc. is looking for further funding to complete its goal of making the first Automatic Legend Painting System.

APPLICATION OF ADVANCED COMPOSITES TO STEEL-BRIDGE RETROFITTING

NCHRP-IDEA Project 51

Dennis R. Mertz [Tel: (302) 831- 2735, Fax: (302) 831-3640],
Michael J. Chajes, John W. Gillespie Jr., and Trent C. Miller, University of Delaware,
Newark, Delaware

IDEA Concept and Product

With an increasing number of structurally deficient steel bridges, bridge owners are searching for feasible and cost-effective alternatives to current rehabilitation and replacement solutions. The rehabilitation of steel bridge girders using advanced composite materials offers the possibility to upgrade structurally deficient bridges and potentially avoid costly bridge replacement by providing either a short-term retrofit or long-term solution. The rehabilitation technique consists of bonding carbon fiber-reinforced polymer (CFRP) plates to the tension flange of steel bridge girders for increased stiffness and strength (Figure 1). While similar research has been conducted for concrete structure rehabilitation, the research presented here is among the initial investigations into steel girder rehabilitation using composite materials. This research focuses on the issues of force transfer and development, fatigue resistance, and durability of the CFRP/steel bond when subjected to sustained loads. An existing steel bridge girder is then rehabilitated using this technique.

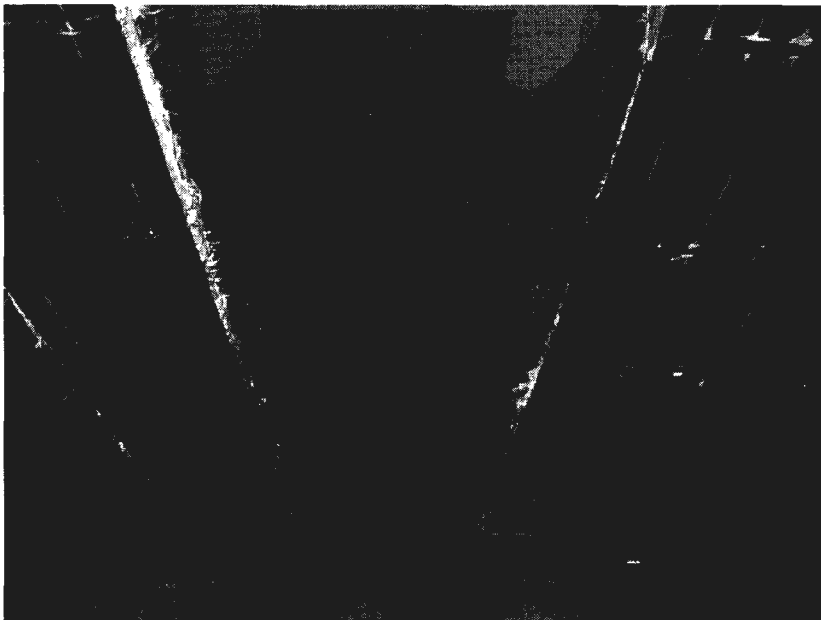

Figure 1

Bridge girders rehabilitated with carbon fiber-reinforced polymer plates.

Project Results

Force transfer and development between the steel and the CFRP plates was examined through a small-scale testing program. The issue of force transfer and development is particularly important when using splices and staggered joints for long-span applications. Experimental test data were used to validate analytical solutions for CFRP plates bonded to a steel flange. Two structural adhesives were analyzed for use in the rehabilitation technique. The rate of force transfer was shown to vary depending on the substrate (steel), reinforcement (CFRP) and adhesive properties and bond-line thickness. High adhesive shear stress levels may affect the nature of the force transfer and must be checked for each application to determine the expected performance. However, the total development length was found to be relatively constant for all parameters studied. Approximately 98% of the force transferred to the CFRP plates occurs within 4 inches. The stagger distance must be adjusted depending on the particular rehabilitation parameters.

The fatigue durability of the CFRP/steel bond was examined through both small-scale and large-scale testing programs. The small-scale testing program verified the adequacy of the fatigue resistance of the CFRP/steel bond when tested at the fatigue threshold (stress level) for a common limiting bridge detail (AASHTO Category C'). The test program was designed to show that typical category C' details would exhibit fatigue problems prior to the CFRP plates debonding. It is important to note that the bridge receiving the retrofit may have accumulated a significant number of fatigue cycles prior to strengthening with the CFRP plates. A full-scale fatigue test was also used to assess the durability of the CFRP/steel bond under cyclic loads. This test program provided more realistic rehabilitation conditions including severely corroded girder surfaces and more representative adhesive shear stresses. After fatiguing two girders for ten million at an adhesive shear stress of 179 psi (similar to that expected in the field retrofit), stiffness data and inspections indicated no noticeable changes in the CFRP/steel bond.

The long-term durability of the CFRP/steel bond subjected to sustained loads was examined. Two full-scale bridge girders were rehabilitated and then tensioned to produce stresses similar to the dead load effects of a concrete deck. Vibrating-wire strain gauges and load cells were used to monitor changes in the test setup and CFRP/steel bond. The initial seven months of monitoring and inspections revealed no noticeable changes in strain data or tensioning force that would indicate creep or debonding. Monitoring will continue over an indefinite period of time.

After addressing the issues of force transfer, fatigue resistance and durability under sustained loads, a full-scale rehabilitation of an existing steel bridge girder was performed (Figure 2). The bridge selected is on I-95 near Newark, Delaware, and experiences roughly 5920 trucks per day with a typical bending stress in the tension flange on the order of 2 ksi. The rehabilitation process proved to be easy to perform and did not require special tools, experience or training. Two structural adhesives were used in the retrofit, and both will be assessed for future use in this application. The full-scale rehabilitation also provides the opportunity to monitor the long-term durability of the CFRP/steel bond when subjected to actual field conditions. These conditions include exposure to fatigue and the environment.



Figure 2

Full-scale rehabilitation of an existing steel bridge girder.

Product Pay-off Potential

This research project has examined a number of issues relevant to the successful application and performance of the CFRP retrofit. The rehabilitation system has been shown to be an effective alternative to current rehabilitation techniques, and long-term durability is being assessed. This procedure offers the possibility to upgrade structurally deficient bridges and potentially avoid costly bridge replacement or delay replacement until the appropriate funds are allocated. The CFRP plates can also be used to quickly strengthen a bridge for special permit loads. The material costs may initially appear high, but the relative ease and speed with which a steel girder bridge can be rehabilitated provides considerable cost savings in terms of labor and inconvenience to the public, due to traffic restrictions, when compared to current rehabilitation techniques. Material cost will continue to decrease with the increased use of this system.

Product Transfer

The full-scale rehabilitation of an existing steel bridge girder performed as a part of this research project was an important step in implementing this rehabilitation system. The Delaware Department of Transportation has scheduled to use the CFRP retrofit on another steel bridge. Once the long-term durability of the retrofit is assessed, it is expected that other departments of transportation will use the rehabilitation system.

ENVIRONMENTALLY FRIENDLY PASSIVATING COATINGS FOR STEEL REBARS

NCHRP-IDEA Project 52

James E. Neely, Jr. (Tel: (724) 482-2163; Fax: (724) 482-2767), Neely Industries, Inc., Butler, Pennsylvania ; Alberto Sagues, University of South Florida, Tampa, Florida; Rodney Powers, Florida Department of Transportation, Gainesville, Florida; and Richard Brown, University of Rhode Island, Kingston, Rhode Island

IDEA Concept and Product

The concept of this proposal is to apply new environmentally friendly, passivating coatings onto rebar to inhibit corrosion and prevent undercutting. These coatings are a new class of environmentally friendly, water-based, inorganic copolymers that contain no heavy metals, heavy metal compounds, or organic solvents. These new passivating coatings have excellent corrosion inhibition performance over a wide range of pH, especially at the high pH that is typical of concrete. These coatings have been shown to passivate the surface of low-carbon steel as shown by electrochemical measurements and other corrosion tests conducted at the University of Rhode Island. Specifically, potentiodynamic scans, A. C. impedance, and salt spray tests have been conducted under a variety of conditions, including simulated marine environments. During these tests passivation layers formed on the bare metal surface at defects deliberately made in coated low-carbon steel. As a result, resistance to corrosion remained high, and no undercutting occurred. Although passivation-type coatings are well-known, currently available coatings contain toxic materials, such as chromates, that do not provide adequate protection at high pH. The new environmentally friendly coatings also contain no volatile organic carbons (VOC's).

Project Results

This report concerns the testing of the ASTM G-109 specimens for the first twelve-month period of saltwater pounding. The total potential and macrocell current evolution respectively for all rebar configurations were measured periodically. Each data set constituted an average of three samples.

The all-black rebar control group showed the earliest and most pronounced evidence of corrosion. Two control specimens attained potentials indicative of corrosion activity (the potentials were -351mV and -310mV versus SCE) after only 4 months of exposure. Current measurements were in agreement with that trend. Upon visual inspection, it was determined that only one of these specimens had cracked.

All the coated systems showed improved performance compared to that of the black bar controls. The coated system performances may be divided into three groups as follows:

Very low corrosion: The inorganic type 1 without flaws coupled with black bar cathodes, and the flawed epoxy coupled with flawed epoxy cathodes, gave the best overall performance, with potentials well into the passive regime and very small macrocell currents throughout the entire test period. The flawed inorganic type 1 coupled with flawed type 1 bar cathodes showed relatively negative average potentials from nearly the start suggesting possible corrosion activity, but average macrocell currents were negligible during the entire reporting period.

Delayed corrosion, moderate current: The flawed epoxy and the inorganic type 2, when coupled with black bar cathodes, showed macrocell current indications of corrosion (but several times less strong than in the black bar controls) after about 200 days of pounding. Potential trends confirmed that observation.

Delayed corrosion, high current: The flawed inorganic type 1 system, coupled with black bar cathodes, did not show indications of corrosion until about 300 days of exposure. However, when corrosion started the average macrocell current was comparable to that of the black bar controls. Potential indications are also indicative of active corrosion. The results reviewed above are preliminary and reflect a short test period dictated by contractual limits. Because of the protective effects of the coatings, evidence of corrosion activity developed so far typically in only 1 or 2 of the triplicate specimens in each category showing activity. A longer test exposure is needed to allow for useful comparison of the behavior of those systems, and also to permit ranking of the other systems that did not yet show any activity. Autopsy of test specimens after full development of corrosion would also provide an essential element for useful performance assessment. In anticipation of continuing investigation, a minimum of data acquisition activity by the Florida DOT laboratories has proceeded for archival purposes. Reestablishment of full data acquisition and data processing and evaluation will take place should continuation support for this project become available in the future.

Conclusions

1. All coating systems investigated provided better corrosion performance than that of the plain steel controls.
2. During the 1-year test period reported here both inorganic coating type 1 with no flaws coupled to black bar cathodes, and flawed epoxy coupled with flawed epoxy, showed evidence of very low corrosion. Flawed inorganic coating type 1 coupled to flawed inorganic type 1 cathodes showed also very low corrosion currents.
3. Flawed inorganic coating type 1 coupled with black bar cathodes showed delay of corrosion initiation but comparable corrosion currents, after initiation, to those of the black bar controls.
4. Flawed inorganic coating type 2, and flawed epoxy, coupled with black bar cathodes showed delay in corrosion initiation and reduced corrosion currents compared to black bar controls.
5. Extended testing and analysis is required to complete the relative evaluation of these coating systems. Data acquisition by Florida DOT is proceeding at a maintenance level in anticipation of a continuation program.

Product Payoff Potential

Commercial use of these passivating coatings is expected to provide corrosion protection to rebar with defects in the coating and to prevent undercutting of the coating that adversely affects structural integrity. The potential to lead to a breakthrough in the service life of coated and damaged rebar exposed to aggressive marine conditions in concrete structures is substantial. Increased service life and reduced maintenance costs would lead to substantial savings of state and federal funds. A reduction in the required thickness of the rebar coating is also anticipated along with a lower cost of the coating. This combination will provide a cost-effective solution to the current corrosion problems experienced in highway applications.

Product Transfer

A number of options for implementing the results within highway practice are possible. Once the passivating coatings are certified for use by the Federal Highway Administration and state departments of transportation, the next step for implementation to practice will be providing commercial quantities of inorganic polymer coatings. One option for Neely Industries, Inc. (NI) to provide such quantities would be by licensing the technology to established coating manufacturers, a strategy successfully utilized by NI for other product developments. Companies interested in licensing high-performance, environmentally friendly coatings have been identified. Another option is the formation of a joint venture company to manufacture the coatings. A partner company for this approach has been identified. The regional manufacture of coated rebar will be done by licensing individual fabrication and coating companies.

NOVEL APPROACH FOR PREDICTING REMAINING LIFE OF CONCRETE BRIDGE STRUCTURES

NCHRP-IDEA Project 54

C. S. Desai [Tel.: (520) 621-6569, Fax: (520) 621-6577], T. Kundu, and M. Keller, The University of Arizona, Tucson, Arizona

IDEA Concept and Product

Evaluation of the remaining life of materials in existing structures is vital for their safe operation and rehabilitation. Design of rehabilitation strategies requires knowledge of the stress-strain-strength behavior of existing structures as affected by factors such as mechanical and environmental loadings. Here it is necessary to evaluate the elastic (deformation) constants (e.g., E and ν), strength (e.g., peak strength), degradation (damage), and in some cases, stiffening (healing) properties. Although various nondestructive test (NDT) methods have been proposed and used in the past, they involve mainly the determination of the elastic moduli. No NDT method integrated with stress-strain or constitutive models is available to define the entire stress-strain response including deformation and strength parameters, and damage properties. In this research the recently developed Lamb wave technique and unified and powerful Disturbed State Concept (DSC) for material modeling will be combined for predicting remaining life of the material. The Lamb wave test data and the stress-strain data will provide the knowledge of disturbance (damage). Then this knowledge will be incorporated in the DSC model to obtain the stress-strain behavior and predict the remaining life. The end product will be a new field equipment that can allow definition of the parameters required for the assessment of remaining life of concrete and other materials.

Project Results and Planned Investigation

This research would integrate the new Lamb wave technique and unified constitutive model based on the DSC so as to develop an innovative methodology for defining the remaining life of the materials. Characteristics including stiffness, failure, plastic deformations, degradation and healing characteristics of materials in such existing structures as bridges and pavements could be assessed. The concept will be validated initially for mortar as the simulant for concrete.

The proposed research involves the following main components:

- Laboratory testing program for typical mortar specimens with different compositions including both stress-strain and Lamb-wave testing.
- Formalization of the DSC model based on the laboratory tests.
- Validation of the model and definition of remaining life.
- Guidelines for the application of the methodology and future research toward industrial use including equipment that integrated the DSC and the Lamb Wave technique for rehabilitation of infrastructure.

Details of the foregoing components are given below.

As the research objective is to develop and validate the concept, initially the main attention will be given to laboratory testing with consideration of a limited number of factors. The latter would include mechanical and Lamb wave testing of flat specimens with different compositions, which would simulate changes in properties due to mechanical and environment loadings.

Procedure: Various flat [10 × 10 (to 15) × 3.81 cm], and beam type (20×10×150 cm long) specimens of mortar or will be cast. As appropriate, the flat specimens can be cut and trimmed from the beam specimens after the Lamb wave measurements. One set of the specimens will be tested for the stress-strain behavior and Lamb wave propagation.

Stress-Strain Testing: An available test (MTS frame) device, with modifications, will be used to test the flat specimens. Special grips and loading-platen systems are available for both tension and compression testing. The test will be performed under both compression and tension loading with strain (displacement) controlled loading. Typical stress-strain data for a mortar from the mechanical testing is shown in Figure 1, which shows loading-unloading-reloading cycles, and degradation or softening due to damage. Such curves will be used to find disturbance, Young's modulus and Poission's ratio (D_σ , E and ν) and strength parameters.

Lamb-Wave Equipment and Testing: The beam specimens will be tested using the specially designed equipment. This special device with the immersion of the transducer in the conical container avoids a number of difficulties, including those involved in the use of contacting transducers used in the past. For instance, the contact area of the coupling fluid and the specimen is small. Also, since the walls of the container are diverging, reflected waves from the

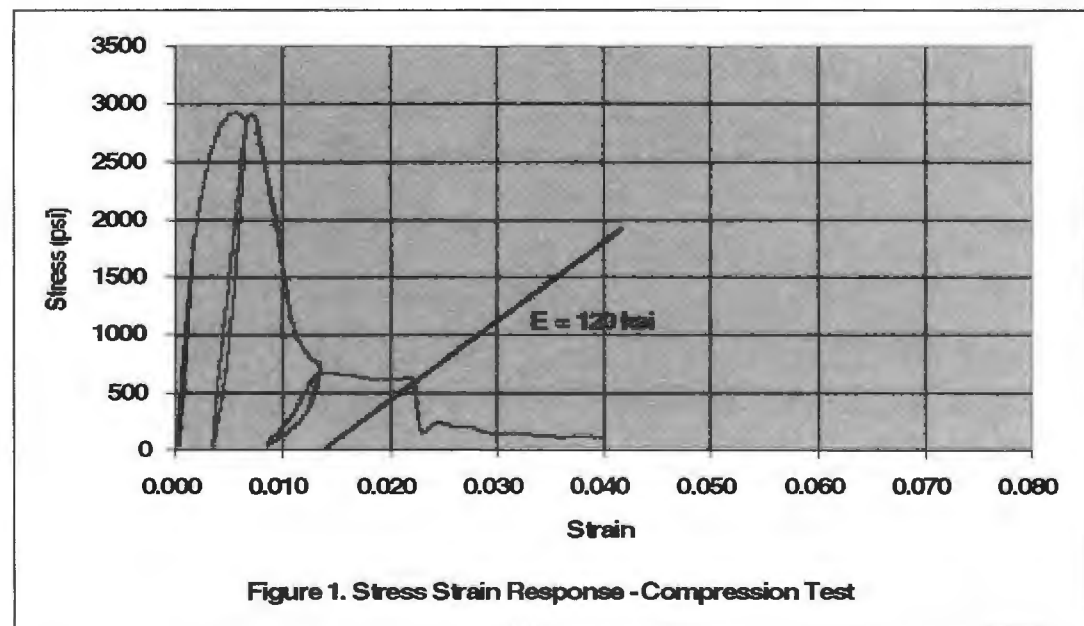

Figure 1

Stress-Strain Curve of Grout

container walls do not reach the transducer face. The transducer can be positioned at the upper end of the container facing the lower base, so that most of the ultrasonic energy is transmitted from the transducer face to the specimen. Furthermore, the transducers can be inclined at an appropriate angle inside the container, which can be changed easily and quickly.

In these tests, the frequency of transmission (f) and the angle of incidence (θ) can be varied and optimized to obtain the best results. The disturbance, D_v , can be calculated from the measurements of wave amplitudes; typical results for $\theta = 25$ deg. are shown in Figure 2.

Correlation: Once the disturbances based on stress, and those from Lamb wave measurements are evaluated, they can be correlated as

$$D_\sigma = f(D_v)$$

The correlation-function, f , then provides the mechanism to find D_σ from D_v . The knowledge of D_σ then allows determination of the entire stress-strain behavior, including deformation moduli, strength and damage or deterioration. This knowledge of the remaining life (stress-strain response) can be used for the design of rehabilitation of given infrastructure.

At this time, the disturbance from the stress-strain data, Figure 1, and from the amplitude-frequency measurements have been correlated. A methodology has been developed to evaluate the stress-strain location, elastic moduli and peak stress (strength) of the material at a given stage during the life of the structure.

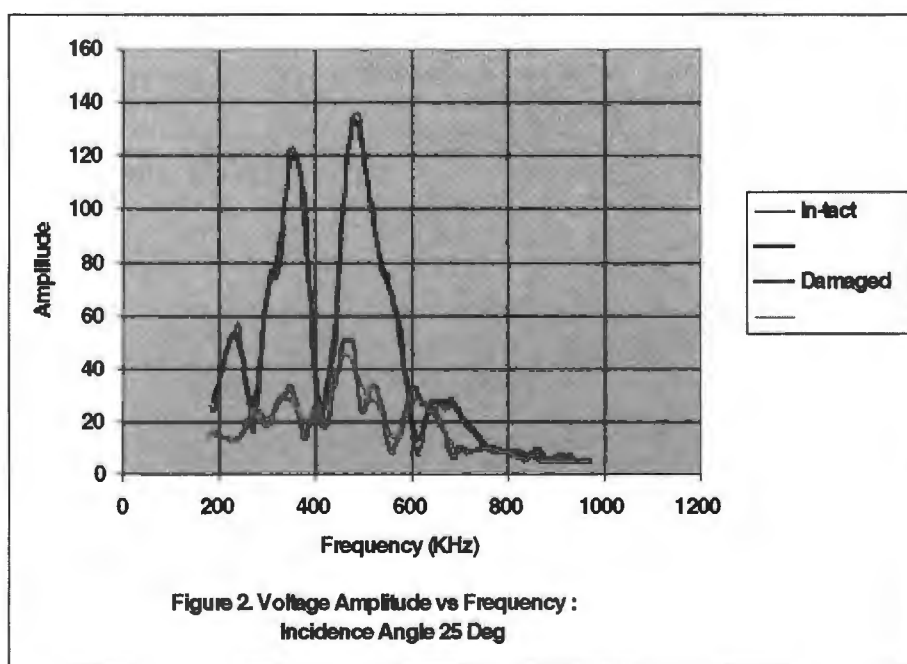

Figure 2

Lamb wave dispersion curves of grout slab

Product Payoff Potential

Under the basic exploratory research stage of this project, the disturbance (damage) from the stress-strain and Lamb wave data will be correlated. This will lead to field applications of the concept, because the Lamb wave technique can be used in the field to evaluate disturbances at different times due to loads and environmental factors. Once the field disturbance is computed, it can be used to define the stress disturbance, which is then used to define the entire stress-strain response.

In addition to the novel integration of the nondestructive testing and constitutive model, this research can lead to new and robust (commercial) equipment based on the Lamb wave technique. This equipment can be used to measure disturbance (damage) in existing structures, over long lengths. Furthermore, it can lead to improved equipment compared to that based on other techniques such as the FWD (Falling Weight Deflectometer), conventional ultrasonic technique, chain drag technique, radar technique, and magnetic resonance technique.

Product Transfer

The steps, discussed above, would allow evaluation of the remaining life based on parameters that can be obtained from standard laboratory stress-strain tests, and the nondestructive measurements. With the help of an industrial collaborator this research can lead to the commercial manufacturing of the Nondestructive – Disturbed State Concept (NDT-DSC) equipment system for field measurements of velocities and attenuation, leading to evaluation of cracking and damage, and stress-strain behavior. This equipment can provide robust and improved measurements of cracking and damage in concrete bridges, compared to those available today. The procedure and equipment can also be used for other materials such as metals and asphalt.

DESIGN, DEVELOPMENT, AND VERIFICATION OF AN ADVANCED IN SITU SHEAR STRENGTH TEST FACILITY FOR ASPHALT CONCRETE PAVEMENTS

NCHRP-IDEA Project 55

A. O. Abd El Halim [Tel.: (613) 520-5789, Fax: (613) 520-3951],

Wael Bekheet and Yasser Hassan, Carleton University, Ottawa, Canada., and

Stephen N. Goodman, Canadian Strategic Highway Research Program, Ottawa, Canada

IDEA Concept and Product

The Strategic Highway Research Program (SHRP) recognized that shear properties are an important indicator to predict rutting potential of hot-mix asphalt concrete (HMAC) pavements. However, current methods of measuring such properties have been limited to time-consuming, expensive, or unrepresentative laboratory analysis. The concept of measuring the in-situ shear properties of an asphalt concrete pavement layer by applying a torque directly to the surface has been initiated at Carleton University in Ottawa, Canada. This concept allows relatively quick measurement of in-situ shear properties with a minimum amount of damage incurred by the pavement surface.

Under the current NCHRP IDEA project, an advanced in-situ device has been developed and fabricated at Carleton University. Known as the In-Situ Shear Strength/Stiffness Test (InSiSST™), the device provides the rapid and accurate measurement of in-situ shear properties of an asphalt concrete layer. Data collected with the InSiSST™ will provide input for more accurate measurement and performance modeling of in-service pavement performance—the fundamental basis of the SHRP Superpave system.

Project Results

InSiSST™ Design

The completed InSiSST™ device is presented in Figure 1. As shown, the components are mounted to a small trailer to provide exceptional portability. The InSiSST™ utilizes an electric motor and gearbox to produce the torque required during the test. The motor/gearbox combination is mounted vertically on a steel platform that is attached to a positioning system incorporating two sets of worm-screw slides working in tandem, also referred to as an “X-Y table.” The top set of slides allows positioning of the platform in the transverse direction (with respect to the trailer orientation). The transverse slides are in turn mounted to a second set of slides allowing positioning in the longitudinal direction. The entire positioning system is mounted to a box-tube frame occupying the space between the tow bar and the axle of the trailer. The test frame is attached to the trailer frame via four screw jacks, one at each corner of the test frame. During transportation of the InSiSST™, the jacks are retracted to hold the frame in the air to prevent damage. Once driven into position, the jacks are extended to lower the test frame to the ground and then continue extending until the weight of the trailer is supported solely by the test frame. Control of the jacks and positioning slides is provided by commercially available electric motor controls. Control of the actual test procedure is provided by a laptop computer. Instantaneous torque and angle of twist measurements are collected on the computer during the test procedure. A large plastic storage box is mounted to

the front of the trailer to house the electronic components. Finally, a generator is mounted to the rear of the trailer to provide electricity for the InSiSST™.

Calculation of In-Situ Shear Properties

As mentioned, the InSiSST™ applies a rotational load (torque) directly to the surface of an asphalt pavement. The torque is transferred to the asphalt through a circular steel loading plate epoxied to the pavement surface as shown in Figure 2. The asphalt is loaded to failure and the induced failure surface is semi-spherical in shape.

The loading case used by the InSiSST™ device is very similar to that investigated by Reissner and Sagoci in the early 1940s. With a circular loading plate affixed to a linear elastic, isotropic half space, the shear modulus of the half space (asphalt concrete) may be determined using the following relationship:

$$T = \frac{16}{3} G \Phi a^3$$

Where: T = Applied torque

G = Shear modulus of the material

a = Radius of the loading plate

Φ = Angular displacement of the loading plate (radians).

The Reissner-Sagoci relationship above was also used to develop and verify a finite element model of the problem assuming linear elastic conditions. In future modelling efforts, the material properties will be altered to linear and non-linear viscoelastic properties, more representative of asphalt concrete, to observe the affect on the resulting stresses and strains.



Figure 1

The in-situ shear strength test (InSiSST™) at Carleton University

Concept Verification and Ruggedness Testing

Initial verification testing was first completed at Carleton University in July 2000 to observe the results of the InSiSST™. Subsequently, field tests have been completed in the City of Ottawa and in the Towns of Bancroft and Petawawa. Test results are very repeatable, with coefficients of variation as low as 1.5%. Complete test results will be presented in the final report, which will be prepared by the end of the year.

Product Payoff Potential

The successful measurement of in-situ asphalt shear properties and the development of a mainstream test facility will yield significant and immediate benefits to the three primary areas of pavement engineering. The first area is *design*. Utilization of the InSiSST™ in conjunction with laboratory testing would be a powerful combination for analyzing the potential of proposed mix designs. The second area is *quality control*. Newly constructed asphalt pavements could be tested to verify acceptable construction practices through the measurement and comparison of in-situ strength parameters with code requirements. The final area is *long-term pavement performance (LTPP)*. Monitoring of field shear strength of pavements with time would allow periodic updating of performance models to more accurately predict future pavement performance. This, in turn, would allow for more efficient allocation of limited rehabilitation funds and also help determine the effect of real world conditions, such as environmental factors, on pavement performance.

Product Transfer

The potential for a simple yet extremely effective in-situ test device has already drawn significant interest from both government and private industry. In addition to IDEA Program funding, the Ontario Ministry of Transportation (MTO) and Regional Municipality of Ottawa-Carleton have committed financial and in-kind support for this investigation. Furthermore, a number of independent consultants have also expressed interest in the potential of the InSiSST.

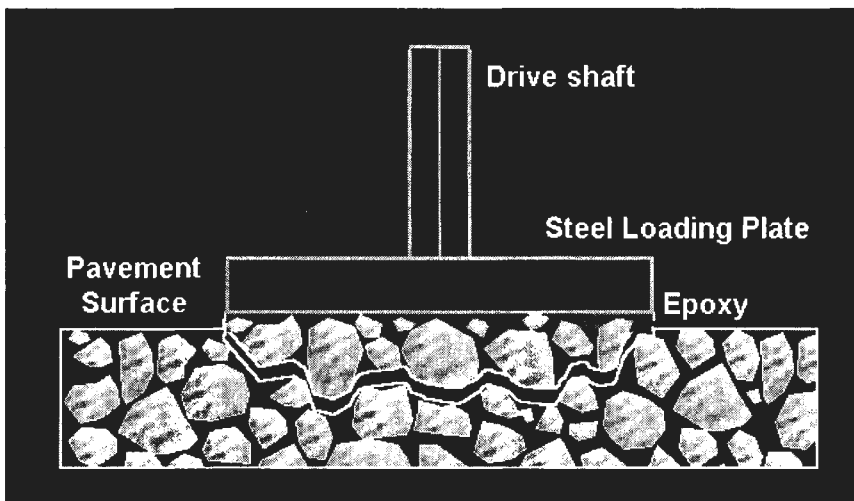

Figure 2

Method of load application for InSiSST™ (side view)

To date, demonstrations of the InSiSST™ have been completed for the Ontario Ministry of Transportation, the NCIIRP-IDEA Program and at the 4th International RILEM Conference on Reflective Cracking in Pavements. Once the current investigation is completed, consultants and contractors will be given instruction on how to use the InSiSST™.

BRIDGE INSPECTION WITH SERPENTINE ROBOTS

NCHRP Project 56

Howie Choset [Tel.: (412) 268-2495, Fax: (412) 268-3348],
Carnegie Mellon University, Pittsburgh, Pennsylvania

IDEA Concept and Product

Every bridge in the United States that spans more than 20 ft must be inspected at least once every two calendar years. The unfortunate reality is that these federally mandated inspections require extensive rigging and traffic control, which consumes 40% to 50% of the inspection budget. Rigging and traffic control are so excessive because the inspector has to see all locations of the bridge, which are often hard to reach on large bridges. This research will develop an innovative technology that resolves these shortcomings. A *serpentine* robot that can “view” the entire bridge through a sensor suite deployed at the end of the robot can be controlled by an inspector, sitting in a truck on the bridge roadbed. This system would reduce the cost of bridge inspection, increase the safety factor, provide better views of the bridge, improve the quality of information, and as an added benefit, decrease traffic delays that are a result of such an operation. The main challenges of the project are to design a new prototype and develop control strategies to move a serpentine robot through the trusses of a bridge.

Project Results

Serpentine robots are difficult to control because they have many degrees of freedom, which are not intuitive for humans to control. To achieve purposeful motion, computerized control strategies are essential. Unfortunately, the coordination of these numerous joints is not handled well in traditional robot motion planning theory. In the proposed work, the robot will use a roadmap, a geometric structure used in the robotic motion planning field, to plan the paths for the robot, which guarantees that its sensors “see” all locations of the bridge with the sensor suite. Typically, the roadmap can be derived from a CAD model of the bridge, but if no such model exists, then the serpentine can construct the roadmap, as it inspects the bridge, from sensor data.

Two theoretic results occurred thus far. The first is that computing geometric structures in man-made environments is difficult because they possess many symmetries that conventional geometric algorithms cannot handle. Investigators overcame this problem and perhaps have identified a new fundamental method for constructing geometric structures in man-made structures.

The second result is identification of a new method for using roadmaps to perform path planning with snakes. A simulator has been created to allow a human to “drive” a snake robot through an environment. Preliminary results show that people can be quickly trained on the simulator, driving the virtual snake through its environment with ease. The simulator is being carefully constructed such that it can be used to control the real snake when it is constructed fully.

Currently, a new snake prototype is being developed. Right now, the first joint has been constructed and is working. Investigators are using this as a base from which more and better joints can be built and linked together to form a longer snake. One joint is shown in Figure 1.

The investigators envision a serpentine robot that will be a linear sequence of robot joints, stacked on top of each other. One of the deliverables of the work is to build one snake robot joint (or bay). The challenge is designing a compact joint with high strength. This is important for bridge inspection because a mechanism will have to reach in a variety of contorted configurations. There are two main classes of compact joint designs: actuated universal joints and angular swivel joints. Current snake robots usually have joints of these two types. In general, the angular swivel joints are more compact but they cannot transmit high torques and so are considered to be weak. On the other hand, actuated universal joints are stronger at the cost of being bulkier.

A new joint design is being developed to address the strength problem. The new design is of an angular bevel joint that is strong yet compact. This joint uses a special kind of angular bevel gear. During the process of designing a prototype, an extensive search for manufacturers of these uncommon gears was made.

The project is the first phase of development of a robotic system for bridge inspection. A standard PC-clone now controls the JPL robot using custom hardware developed by the principal investigator's laboratory. The snake robot was retrofitted with a camera, so now the inspector can view the bridge from a remote location to the robot. See Figure 2.

Product Payoff Potential

Implementing snake robots in inspection will give more options to the bridge inspection teams and increase safety for the work crew. Since half the time to perform an inspection is dedi-

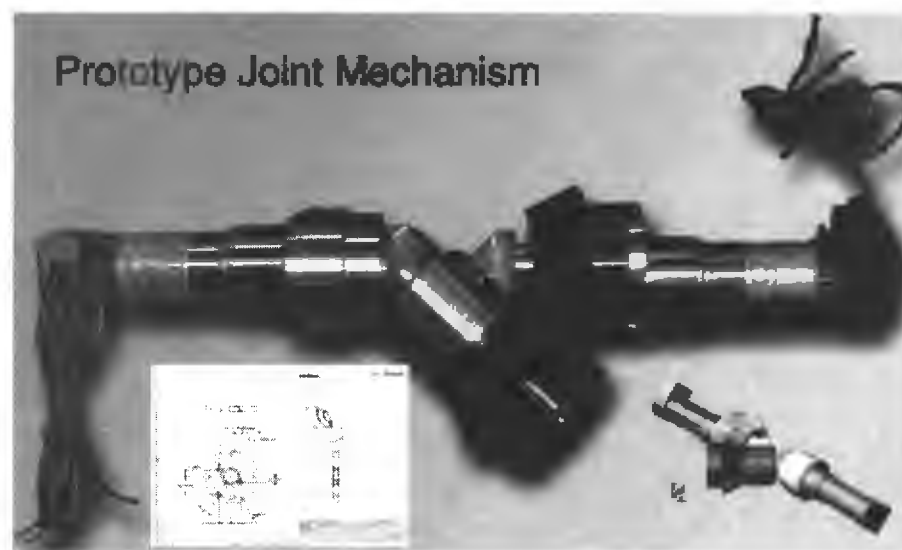

Figure 1

Prototype joint mechanism

cated to rigging the bridge for the inspector, the use of robots can decrease the time for inspection by a factor of two, which in turn will decrease the cost of inspection. With improved technology, better inspections may be possible. This may obviate the need to downgrade bridges because problems will be caught earlier. It seems that some bridges are often “downgraded” in terms of weight limits, rather than repaired. With better sensing capabilities industry and commerce will not have to suffer the immeasurable costs of bridges that cannot support their needs for large payloads.

Product Transfer

The developments arising out of this project are the first step toward the envisioned bridge inspection and other similar systems and are critical to the successful transfer to an application program in the field.

Search and Rescue: Urban search and rescue could very much benefit from the ability of serpentine robots to surgically enter an environment and look for survivors.

Pipe Inspection: Serpentine robots can use their many degrees of freedom to reach deeply into a complicated network of pipes without damaging them, just as a surgeon can use an arthroscopic surgical instrument to make repairs inside the body without damaging it. Using the methods in this work, serpentine robots can perform inspection, maintenance, and repair deep inside a pipe network without having to excavate any roadways to find the location.

Bridge Painting: Spray painting requires depositing a uniform thickness of paint on each target surface. A large expense of painting derives from the size and complexity of the object to be painted. Bridge painting involves extensive labor, support structures, health risks, and time. A serpentine robot could bypass these dangers and reduce these costs by matching a human painter’s versatility while adding automation to the process. The motion planning and demonstration of bridge inspection is a necessary component for a bridge painting system, and thus bridge inspection is an excellent sub-goal that will lead to a bridge painting robot.

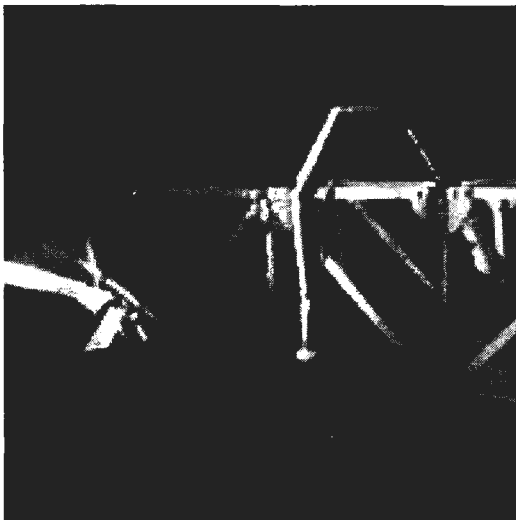

Figure 2

Serpentine robot completing a model bridge inspection

STABILIZATION OF LANDSLIDES USING WICK DRAINS

NCHRP-IDEA Project 57

Paul M. Santi [Tel.: (573) 341-4927; Fax: (573) 341-6935]
and C. Dale Elifrits, University of Missouri, Rolla, Missouri

IDEA Concept and Product

A method has been developed to use soil wick drains for a novel application of landslide and slope stabilization. Wick drains are flat, fabric-coated plastic channels, which were initially developed to be vertically driven into the ground using a specially adapted crane. The wick drains accelerate consolidation and settlement by an order of magnitude by significantly shortening the flowpath for water to exit a soil layer. They were first developed in the 1930s and have found widespread use since the 1970s, when durable plastic came into use, replacing the cardboard channels originally used. This study has developed equipment to install wick drains horizontally, so that they might be used to drain landslides. Drains have been installed in several instrumented landslides to prove the effectiveness of the procedure.

The method of installation is to use a bulldozer or hydraulic excavator to push a small-diameter steel pipe into the hillside (Figure 1). The pipe sections are preloaded with a continuous wick drain, which is attached to a disposable drive plate at the front end of the pipe. At the target depth, the pipe is withdrawn, leaving the wick drain in place. Over 100 drains have been installed for the project, totaling over 4,800 feet in length. Drains as long as 100 feet have been pushed through materials with Standard Penetration Test stiffness as high as 28.

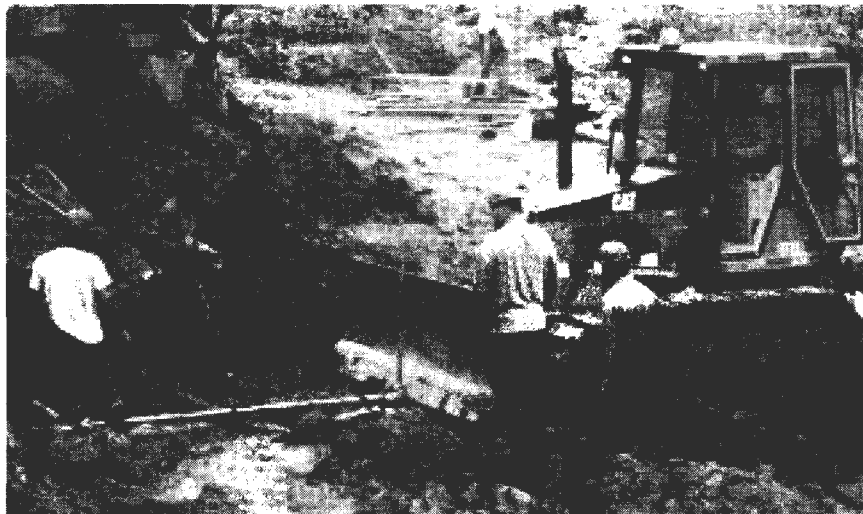

Figure 1

Installation of horizontal wick drains using a small bulldozer and 2" diameter drill pipe containing the wick.

Project Results

Testing of the horizontal wick drain concept and the installation technique took place in three stages. First, a 60-cubic yard test embankment was constructed and instrumented with piezometers, soil moisture meters, and survey markers. One-half of the slope was stabilized with six wick drains. The other half of the slope was not stabilized, so that it could be used as a control point in the experiments. Once a groundwater table had been developed in the slope by induced infiltration, the slope was watered with sprinklers to simulate a 100-year 24-hour rainfall (7.5"). During this simulation, water levels, wick drain discharge, and slope movement were measured and recorded.

The results of the test embankment simulations verify the effectiveness of the wick drain system. The wicks showed substantial water flow, the piezometers on the stabilized side of the embankment showed significantly lower water levels than the unstabilized side, and the survey stakes on the stabilized side showed approximately one-third as much settlement and movement as the unstabilized side.

The second stage of testing involved installation of wick drains in a variety of materials and with several different types of driving machinery (bulldozers, trackhoe excavators, and modified vertical wick-drain-driving cranes). The sites included a fill embankment near Boonville, Missouri on Interstate 70 (10 drains); a natural loess slope in St. Joseph, Missouri on I-229 (six drains); fill embankments on State Highway 13 near Rio Blanco, Colorado (six drains) and Meeker, Colorado (11 drains, Figure 2); and a fill embankment on State Highway 165 near Rye, Colorado (21 drains).



Figure 2

Completed landslide drain system in a fan pattern. Note the water exiting the wick drains (Inset: Close-up of water drainage from a wick drain).

The third stage of testing involved a full-scale landslide stabilization of a site on State Highway 545 near Jasper, Indiana. Forty-four drains totaling 2,613 feet in length were installed.

The landslides are currently being monitored to track water levels, slope movement, and roadway movement to verify the effectiveness of the wick drains. Design guidelines have been established to assist in planning drain location, length, spacing, orientation, and number.

Product Payoff Potential

Current highway practice in mitigating landslides is cost- and time-intensive. Stabilization of active landslides involves significant earthmoving, drilling, or construction of drainage or buttress features. Movement of ground not originally recognized as active landslides results in repair expenses and road closure.

Current landslide drainage techniques employ drilled drains, which require periodic maintenance to reduce clogging and specialized drilling rigs with skilled operators to install the drains. Horizontal wick drains are encased in a geotextile fabric that serves as a filter and prevents clogging of the drains by fine soil. No specialized drilling rigs are required and installation equipment is easily and economically procured, and installation crews need only a day or two of training. Horizontal wick drains can be installed for approximately one-half to one-fourth the cost of drilled drains.

Product Transfer

The use of horizontal wick drains could revolutionize the way we deal with landslides. The results of this study provide a clear, defensible analysis of equipment preparation, drain installation, and drain effectiveness. Stabilization efforts have been performed in cooperation with the American Wick Drain Corporation, the Nilex Corporation, the Colorado Geological Survey, and the Missouri, Colorado, and Indiana Departments of Transportation. A demonstration video has been prepared and distributed to interested agencies to show the installation process and equipment.

Follow-up work will seek to complete full-scale stabilization of landslides for additional agencies, to identify more robust wick driving systems, and to explore methods of emplacing sand filters around the drains.

LONG GAUGE-LENGTH INTERFEROMETRIC FIBER-OPTIC SENSORS FOR CONDITION ASSESSMENT OF BRIDGE STRUCTURES

NCHRP-IDEA Project 58

Jeffrey A. Laman [Tel.: (814) 863-0523; Fax: (814) 863-7304],
Timothy E. McDevitt, and Karl M. Reichard, Pennsylvania State University,
University Park, Pennsylvania

IDEA Concept and Product

This IDEA project encompasses the research, development, and refining of a long gauge-length, optical fiber-based sensing system to be used for the assessment of bridge structure condition and damage detection. Two distinct detection system innovations will be derived from the current project: an optical-based strain sensing system and a long gauge-length sensor. In conjunction with the implementation of the new sensing system, damage detection techniques will be evaluated for compatibility with the proposed system.

Project Results

The study consists of three phases. Phase I consists of finalizing the project design in conjunction with a regional advisory group. Phase II consists of laboratory research to establish the major components of the fiber-optic-based system, and develop a field system. Phase III testing was conducted at an in-service highway bridge site in Central Pennsylvania on Rte. 220 by instrumenting the existing concrete T-beam bridge (see Figure 1) with the prototype fiber-optic-based condition assessment system.

Phase I:

Major testing objectives and research program design were finalized during the first phase of the work. Objectives, system design, and signal processing techniques were established for both Phase II and Phase III. The research program was presented to and discussed with a regional project advisory group. The final methodology and plan of work was developed to guide Phase II and III test programs.

Phase II:

The fundamental testing in Phase 2 optimized several features of the system, particularly as they relate to concrete bridges:

1. Evaluated adhesives for characteristics of bond, ease of application, and cure rates.
2. Evaluated fiber types for operating wavelength, polarization, and core and cladding degree and composition of doping for suitability to the proposed application.
3. Evaluated several light input sources, including lasers and light-emitting diodes.
4. Evaluated commercially available photo-detectors for sensitivity and suitability to the application.
5. Identified the influence of temperature sensitivity on the process of damage detection and condition assessment and identify methods of including a reference

Phase III:

Phase III consisted of testing an in-service central Pennsylvania concrete highway bridge (Figure 1) by instrumenting (Figures 2 and 3) the bridge with the prototype fiber-optic-based condition assessment system. This phase consisted of several tasks:

1. Evaluate and further develop the system for field applications.
2. Evaluate the durability of the system under highway conditions.
3. Evaluate the data and repeatability of the testing.
4. Evaluate the static and dynamic response measurement capabilities (Figure 4).

A study of long gauge-length, fiber-optic sensors has been conducted by the research team as part of Phases I and II. A dual-mode, long gauge-length fiber system has been developed. The interferometric system of strain measurement is used to measure dynamically induced strains along the structure. Damage will be induced to the structure during the measurements. Correlation coefficients of the frequency response functions between the various damaged states and the baseline, undamaged state were calculated from the response. There is a very discern-



Figure 1

West elevation of Bridge 14-0220-0350-0690.



Figure 2

Installed optical sensor.

ible pattern of frequency response function shifts as the damage progresses, demonstrating that the long gauge-length sensor has promise in the proposed application.

Product Payoff Potential

The research program has been designed as a sequence of research and development consisting of (a) interferometric sensor design, (b) engineering of a fiber-optic-based condition assessment system, (c) development and evaluation of damage detection techniques, and (d) full-scale implementation of the system and damage detection methodologies on an existing bridge. The project consists of three phases: planning (Phase I), laboratory study (Phase II), and field evaluation (Phase III). Tasks for Phases II and III were designed in conjunction with the advisory group as part of Phase I. Phase II consisted of a laboratory study on a concrete test structure and Phase III consisted of a full-scale test and implementation of the system on an existing concrete bridge structure. The research program is designed to determine the relationships between the configuration of a long gauge-length fiber-optic sensing system and the ability to detect damage in large civil structures. The system has been developed and optimized in the laboratory as part of the Phase II.

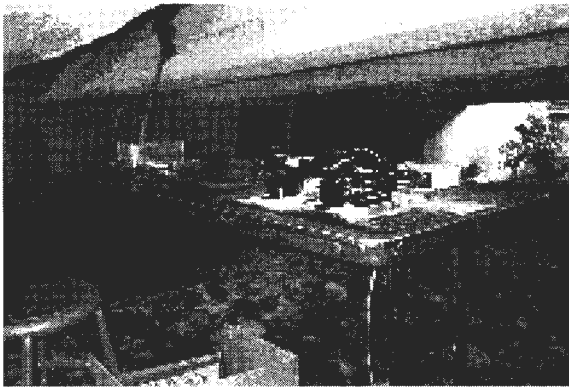

Figure 3

Data acquisition setup.

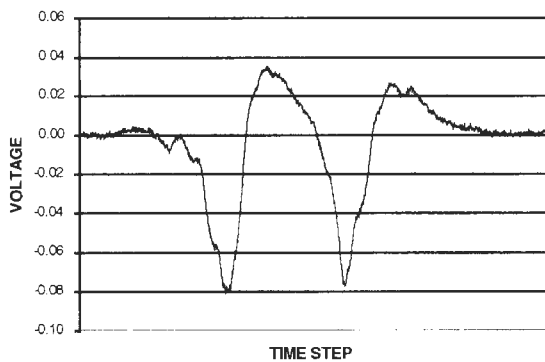

Figure 4

Typical dynamic truck time-history.

Product Transfer

This project consists of development and demonstration of the optical fiber-based instrumentation and data reduction methodologies. The proposed research will result in diagnostic technologies that will enhance early detection of deterioration and thus may reduce the time between repair and resumption of service. Publication of research results in the form of an NCHRP report, in TRB special reports, and in other technical journals will be undertaken by the research team to further the transfer of knowledge gained through the proposed research.

CONTROL SYSTEMS FOR LIVE LOAD AND LIVE LOAD EFFECTS ON BRIDGES

NCHRP-IDEA Project 59

Andrzej S. Nowak [Tel.: (734) 764-9299; Fax: (734) 764-4292],
University of Michigan, Ann Arbor, Michigan

IDEA Concept and Product

The objective of the study is to develop an integrated system for monitoring live load and verifying live load carrying capacity of highway bridges. The anticipated major contributions will include: improved field testing procedures using remote sensors and transmitters for site-specific weigh-in-motion measurement of trucks; component-specific fatigue load spectra; on-site data processing; calculation of critical truck loads (illegal overloads); accumulated fatigue load spectra; maximum deflection; derivation of reliability-based criteria for acceptability limits (truck weight, axle load, number of load cycles, deflection); elements of active control with on-site response to critical overload as determined by comparison with the developed reliability-based criteria (e.g., illegal truck, exceeded fatigue load limit); integration of truck weigh-in-motion with diagnostic testing (e.g., to verify load distribution factors) and proof load testing (to verify the minimum live load carrying capacity); and derivation of reliability-based criteria for establishing proof load level for bridges.

Project Results

The first year of research has just been completed. The objective of this project is to develop an efficient control system for highway load effects, which involves the control of various parameters including: truck weight (axle weights and axle spacing), truck load distribution on bridge girders, dynamic load, as well as strain, stress, and deflection of bridge components. This study involves experimental and analytical efforts.

Seven bridges were tested this summer. The load was applied in the form of fully loaded 11-axle trucks, each weighing about 150 kips (650 kN). The considered loading combinations include a single vehicle and two trucks side-by-side. The results of these and previous tests indicate that the girder distribution factors (GDF) specified by AASHTO for the spans from 10 to 30m are rather conservative. Dynamic load factors (DLF) were also measured for a single truck and two trucks side-by-side. It was observed that the dynamic load is not related to static load, and therefore DLF (defined as the ratio of dynamic load and static load) decreases for larger static load. A typical example of the relationship between static and dynamic strains and DLF are shown in Figure 1. Vertical axis represents DLF, and horizontal represents absolute values of strain. Open circles denote static strain and solid squares denote dynamic strain.

In the coming months, the field testing will continue, to obtain a better data base for the formulation of proposed changes in the bridge evaluation procedures. The analytical study will also continue on the development of probability-based approach to calculating the optimum proof load level.

Product Payoff Potential

The control system for highway load effects will be presented to state departments of transportation for possible applications. The truck traffic control will save a considerable amount of dollars in the budget assigned for bridge maintenance (because of a more accurate site-specific evaluation). The Michigan Department of Transportation (MDOT) has already benefited from the project, because the initial tests justified the use of more permissive truck load distribution factors and lower dynamic load factors (0.1 in most cases, instead of 0.2–0.3 required by the code).

Product Transfer

The results of this project are implemented on a regular basis. The project team works closely with the technical staff of MDOT and the research work progress is presented at meetings and in monthly reports. In particular, practical needs are discussed to direct the research effort accordingly. The field work is carried out on bridges selected in coordination with MDOT.

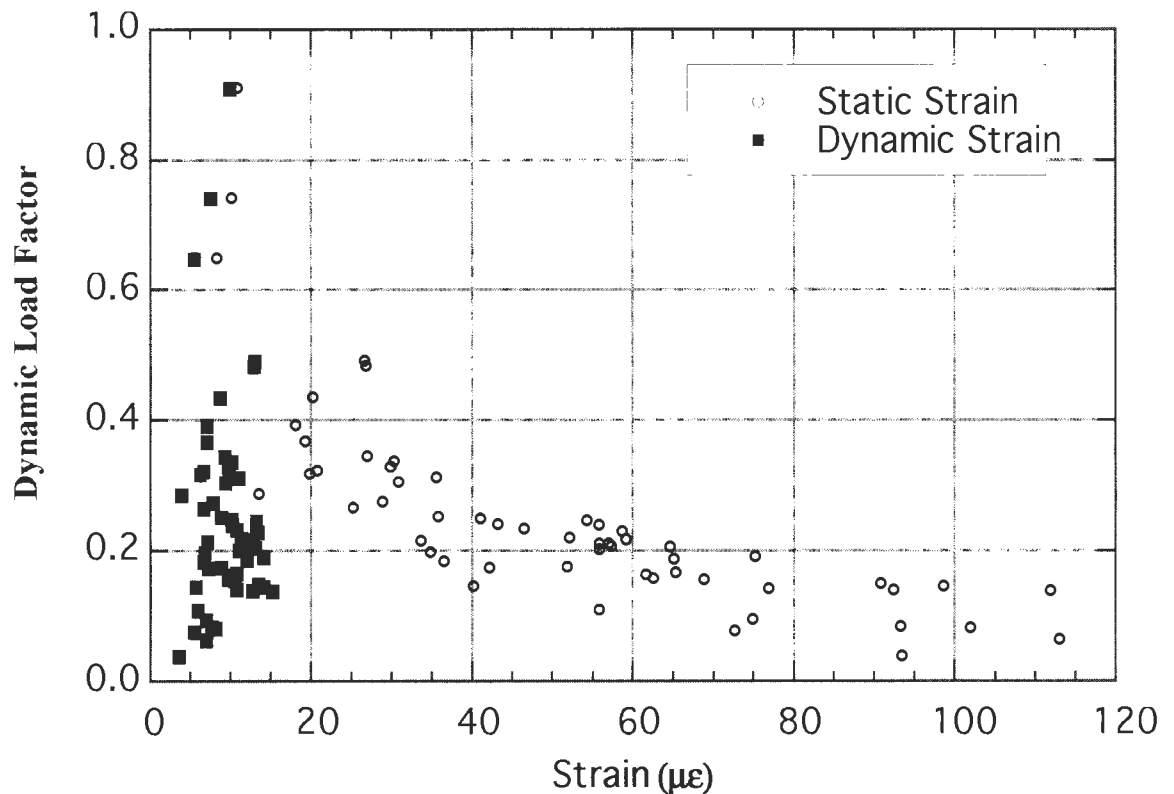

Figure 1

Measured static and dynamic strain vs. dynamic load factor (DLF) for the tested steel girder bridges.

THE PAVEMENT THICKNESS DENSITY METER

NCHRP-IDEA Project 61

Kenneth R. Maser [Tel: (781)648-0440; Fax: (781) 648-1778],
INFRASENSE, Inc., Arlington, Massachusetts

IDEA Concept and Product

The proposed Pavement Thickness Density Meter (PTDM) will be a portable, easy-to-use device for automatically and nondestructively determining pavement thickness and density at the time of construction (Figure 1). The device overcomes the time and coverage limitations, and safety requirements of traditional methods. It provides 100% coverage that will enable highway agencies to locate and correct all areas of substandard pavement thickness and density.

Project Results

Project activities during this first stage have included antenna evaluations, software development, field data evaluation, development of system specifications, and a meeting with the regional expert panel. Three different antenna were evaluated technically, each supplied by Geophysical Survey Systems, Inc (GSSI). Applications considerations, however, suggest the use of a non-contact horn antenna since it has the versatility to be used: a) directly behind the paver for QC; b) behind the roller compactor for QC/QA; and c) at the end of the paving day for QA. Tests were carried out in the laboratory, on a controlled thickness test strip, and on a newly paved section of road on Route 1 in Portsmouth, New Hampshire. Figure 2 shows the deployment of the three candidate antenna configurations for the Portsmouth test. The data were analyzed using standard software for asphalt thickness and density. The thickness results agreed closely with available core data (Figure 3). Prototype real-time software was developed and tested on the field data. The prototype software was designed to operate with input from a field technician, and to automatically output the thickness and density as the data were collected. The software has been successfully tested on the field data. A set of system specifications has been proposed and discussed with the regional expert. The focus of the next Stage of this project will be to zero in on the final antenna approach and to carry out laboratory evaluations to develop a baseline of data. Software development will continue during this stage so that prototype software will be available for Stage 3 field testing.

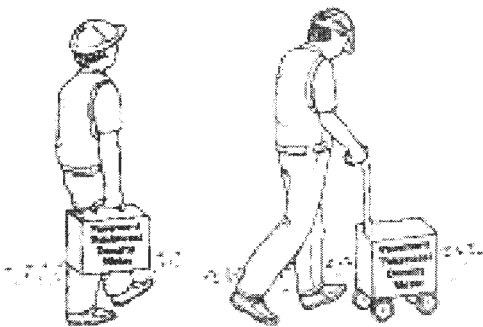
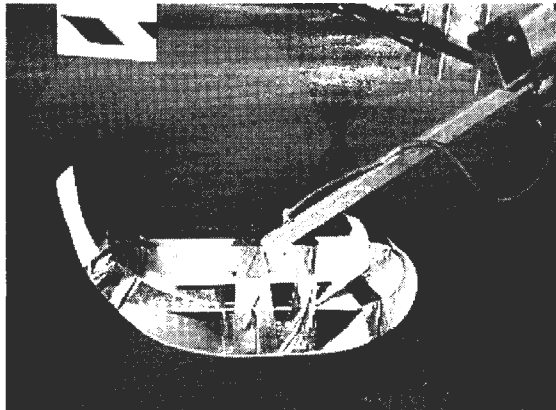
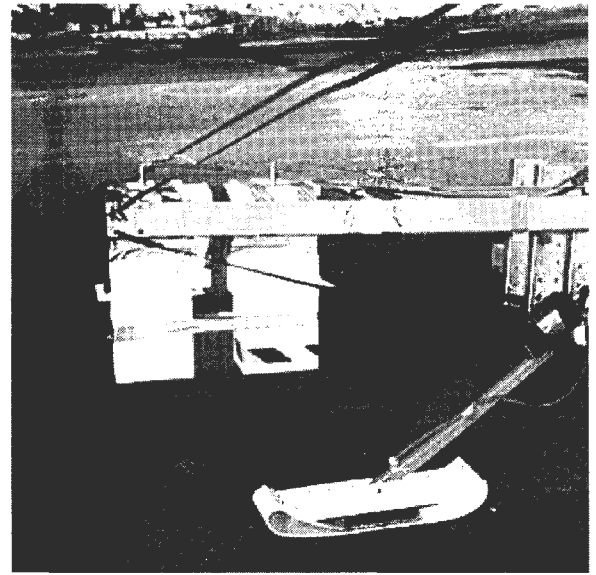

Figure 1

Portable PTDM



ground-coupled
antenna with spacer



horn
antenna

ground-coupled
antenna

Figure 2

Field testing of different types of antenna

The PDTM will enable agencies to maximize pavement life and minimize life-cycle costs by accurately and completely determining, at the time of construction, if pavement has been built according to specifications. With this capability, agencies will be able to save millions of dollars in premature, unplanned and unnecessary repairs, and rehabilitation caused by inadequately constructed pavement. The proposed PTDM would be available at a price comparable to other pavement nondestructive testing devices; and thus would be applicable for routine use by contractors, state highway testing organizations, and by private and contracted testing laboratories. This testing device would represent a strong force toward increasing the quality of construction.

Product Transfer

Should the results of this work prove favorable for commercial development, pre-production units would be fabricated for further demonstration and testing. The project team includes GSSI, an equipment manufacturer who would fabricate these units, and who would ultimately manufacture the commercial device. The commercial PTDM would be marketed and sold through distribution means similar to those used for other pavement test devices.

A NEW TECHNIQUE FOR CHARACTERIZING PAVEMENT SURFACE PROFILES AND TEXTURES

NCHRP-IDEA Project 62

Cam Nguyen [Tel.: (979) 845-7469; Fax: (979) 845-6259]
and Tom Scullion, Texas A&M University, College Station, Texas

IDEA Concept and Product

This project aims to develop a high-resolution millimeter-wave sensor and to demonstrate its use in real time measurements of transverse and longitudinal profiles, micro/macro textures, and detecting areas of mix segregation in newly constructed asphalt surfaces. Compared to other technologies, millimeter waves have two uniquely distinct characteristics that can be exploited for non-destructive, high-resolution surface measurements: higher frequencies and larger absolute bandwidths. These characteristics together can produce a system that has fine resolution and small size.

Project Results

Several lab specimens were constructed, representing the range of pavements and materials found in the field, to be used in evaluating the sensor. These samples include coarse chip seed (high macro texture and moderate micro texture), polished surface (low macro and micro textures, and poor skid resistance), fine grained surface (low macro texture and high micro texture), tined concrete (high macro and micro textures, and good skid), and segregation.

Various system architectures were investigated, from which the final sensor system was derived and performed its analysis and simulation. Figure 1 shows the sensor block diagram. Design of various components needed for the sensor is completed and integration for the sensor has begun.

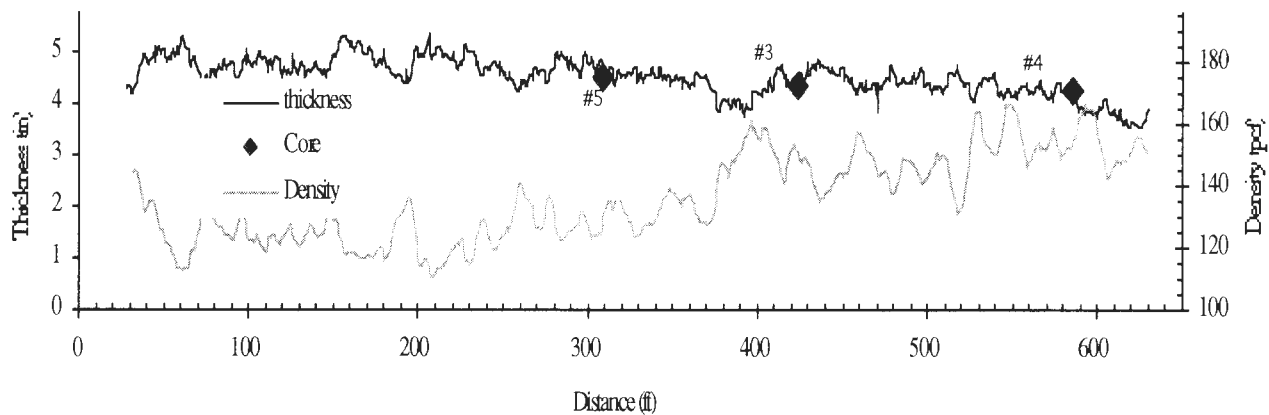

Figure 1

Sensor block diagram

Product Payoff Potential

The sensors to be developed in this study will be capable of being installed in highway data collection equipment. They will provide critical inputs to pavement management systems in terms of pavement rut depths and skid resistance (from macro/micro). If successful, the segregation application will be a valuable tool for checking the quality of newly constructed pavements and new surfaces.

Product Transfer

Texas Transportation Institute (TTI) at the Texas A&M University is working closely with the states of Florida, Texas, and North Carolina in implementing advanced technologies for pavement applications. These states, as well as others, are likely potential users of the proposed millimeter-wave system once it is developed, and serve as the bases for transferring the results to transportation practice. To this end, research results will be disseminated to state and federal transportation organizations. Demonstrations of the new millimeter-wave prototype, once developed, will be provided to these organizations.

The departments of transportation of Texas and North Carolina have agreed to cooperate and support this development effort, and have expressed strong interest in using the new millimeter-wave system. TTI will also make available to the project's research team access to its National Skid Resistance test site at the Texas A&M Riverside campus and also the recently constructed TTI roughness calibration facility. These are actual pavement sections with either known surface characteristics or known rut depths.

MANUFACTURE AND TESTING OF A FILAMENT-WOUND COMPOSITE BRIDGE SUPERSTRUCTURE

NCHRP-IDEA Project 63

D. Parsons [Tel.: (217) 333 2690; Fax: (217) 333 9464]
and Scott White, University of Illinois, Urbana-Champaign, Illinois

IDEA Concept and Product

This project investigates the manufacturability and the structural performance of the composite bridge superstructure shown in Figure 1. The bridge consists of two components: a series of inner cells, lying parallel to the direction of traffic, and an outer shell. Special consideration was given to three factors when this design was developed. First, filament winding was chosen as the basic manufacturing procedure, since it allows for automated manufacturing, with faster fabrication cycles and reduced manufacturing costs. Second, attention was given to the transfer of shear between the different components; the oval inner cells provide sufficient contact area to reduce the shear stress to acceptable values. Third, additional stiffness and strength was developed by incorporating shell behavior into the structure, rather than relying solely on plate bending common in standard bridge deck designs. Shell action is obtained by providing contact between the inner cells.

Project Results

The project consists of two parts: the manufacture of several small-scale models of the proposed composite bridge, followed by experimental testing of the models.

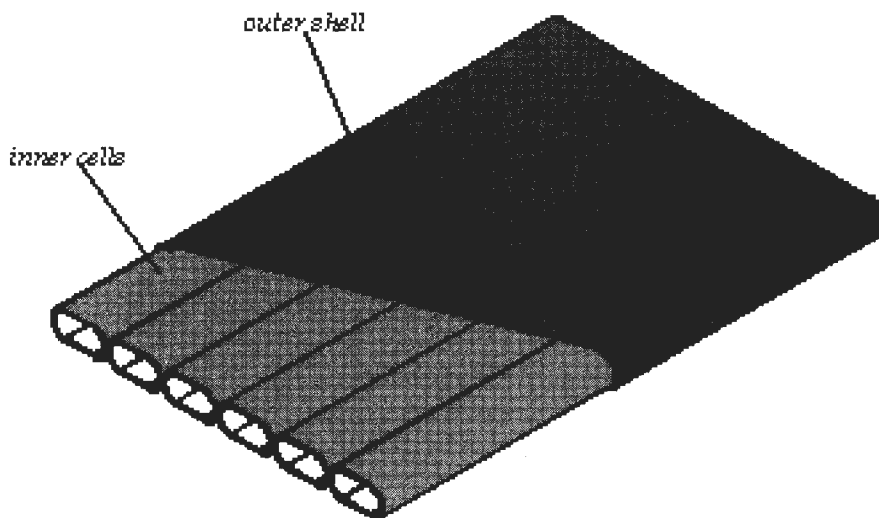

Figure 1

Bridge structural system.

The inner cells of the bridge deck are filament wound separately. The mandrel is designed so that it can be extracted after cure; this is done by wrapping the mandrel in a teflon sheet. The inner cells are wound and cured separately in succession. A total of six is required for each bridge deck prototype system. After manufacturing, the inner cells are trimmed and prepared for integration with the outer shell. The outer shell structure is also filament wound by winding directly onto the inner cells. Figure 2 shows the outer shell being wound onto a series of six inner cells that are coupled together with a mandrel framing system. The frame is assembled to end pieces containing a coupling that fit into the filament winder chucks.

Structural tests are currently being performed to determine the strength and stiffness of the manufactured models when they are subjected to typical bridge deck loads specified by AASHTO. Figure 3 shows the testing equipment that has been constructed to perform the test. A load is applied at the center of the bridge; deflections and strains are measured at various locations throughout the bridge structure. These measurements will be used to verify or correct predictions of detailed finite element models that have already been built. This phase will finally produce results that will indicate the performance of a full-sized deck used in an actual bridge.



Figure 2

Filament winding of the outer shell onto the inner cells.



Figure 3
Testing equipment.

Product Payoff Potential

Much progress has been made in the integration of advanced composite materials with components of the civil infrastructure. However, additional work is required before practicing structural engineers routinely employ these materials. The inherently conservative designer needs to see innovative designs thoroughly proof tested before risking their use in real projects. Successful completion of this project should generate sufficient data to convince engineers that the proposed design is structurally sound and can be built economically. These data will form the basis of future funding from industrial sources, culminating in the construction of actual bridge systems.

Product Transfer

A private bridge design and construction company has expressed interest in the process. If the project succeeds, discussions will continue with this and other companies to identify a test site for this structure. Once tested, the bridge system can be presented as a proof-tested design to state departments of transportation and material manufacturers.

QUANTITATIVE CHARACTERIZATION OF ASPHALT CONCRETES USING HIGH-RESOLUTION X-RAY COMPUTED TOMOGRAPHY (CT)

NCHRP-IDEA Project 64

Richard A. Ketcham [Tel: (512) 471-0260; Fax: (512) 471-9425]
and William D. Carlson, University of Texas, Austin, Texas

IDEA Concept and Product

The principal thrust of this project has been to develop a software application called "Blob3D," which utilizes industrial high-resolution X-ray computed tomography (CT) data to provide quantitative, nondestructive evaluation of asphalt concrete pavements. Images from industrial CT have already proven useful for 3D visualization of aggregate structure and void concentrations in 6-inch core samples, providing valuable insight into the internal structure of concrete. Features that can be observed that almost certainly affect pavement performance include whether the aggregate is poorly mixed, with large and small aggregates separated from each other, and whether there are any unusual or aligned concentrations of void spaces. The software developed under this project allows the next step to be taken, making it possible to analyze a core of asphalt concrete and determine its complete material makeup: the location, size, shape of each aggregate, contact relationships among aggregates, and distribution of void space. In other words, it is possible to determine the complete internal structure of a pavement after it has been mixed and poured. In the immediate term, this analysis provides a wealth of new information that can be used to directly assess mechanical characteristics of the material. In the future, such a description promises to serve as the basis for a new generation of techniques for analysis and improvement of pavement design. Blob3D is designed to define and separate tens of thousands of distinct and irregular particles from a volume of CT data comprising tens to hundreds of megabytes. A rich and unique set of tools and techniques to process and interact with the data in 3D has been developed in support of this effort.

Project Results

This project completed the initial conception, design, and development of this software to obtain the required analyses. In the initial stages of this project, the program architecture was laid out and the data analysis was divided into three stages, described below: segmentation, separation, and extraction. Software to accomplish each of these tasks was developed in parallel, and successively improved and tested, to achieve a working package. Figure 1 shows an example of a CT scan of an asphalt concrete core.

Segmentation is the process by which each voxel (3D pixel) in a data set is classified as belonging to a particular component, such as a certain type of aggregate, asphalt, or void space. Graphical analysis tools to support segmentation include filters for noise reduction and edge enhancement. Actual segmentation is done by thresholding, or selecting a range of voxel grayscales to be classified in a particular way. Specialized thresholding tools that utilize additional data (e.g., local connectivity of voxels within certain grayscale ranges) to improve segmentation were also developed and implemented. An advanced graphical interface allows real-time, interactive experimentation with the various filters to quickly achieve an optimal result.

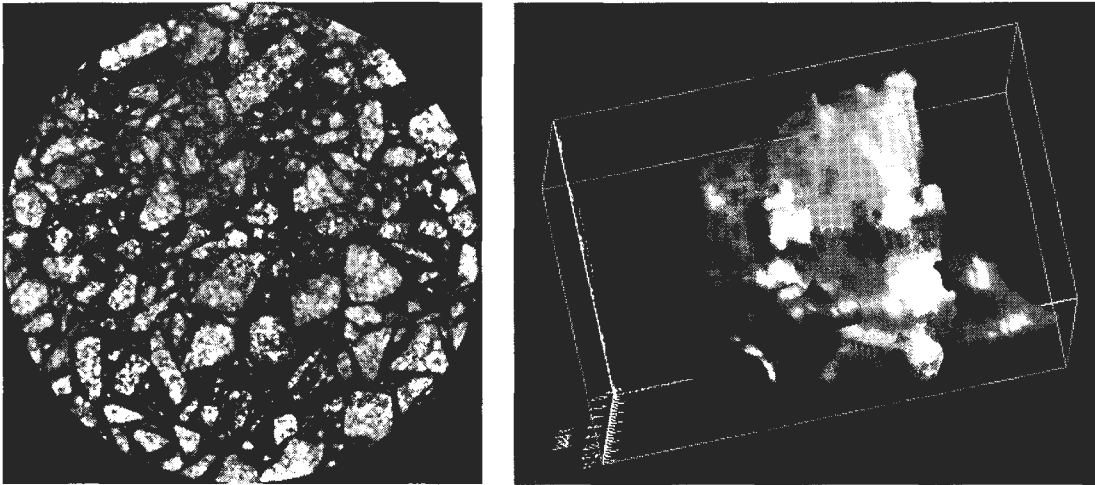

Figure 1

(a) Example CT scan of an asphalt concrete core. Field of view is 145 mm. (b) Sample Blob3D program view showing 3D processing to extract aggregates from scan data.

Separation is the process by which contiguous voxels classified as a particular component are divided into a series of distinct objects. A series of contiguous (touching) voxels of a single material is characteristically called a *blob*, from which the name of this software is derived. Because in optimal asphalt concrete all aggregates should be in contact, the set of voxels corresponding to a certain material may comprise a continuous structure spanning the entire volume. Separating a blob that incorporates a potentially unlimited number of individual objects into its component parts is a problematical computational task, and solving this problem was the centerpiece of the technical challenge of this project. Associated challenges include being able to process the potentially large amounts of data involved in real time. These obstacles have been surmounted by a series of algorithms enabling efficient searching of the data volume and graphically based, user-controlled manual and semi-automatic separation of objects.

Extraction is the third stage in the data analysis process. Once a CT data volume has been segmented and separated, it then becomes possible to mine it for data. Thus, a third module of Blob3D is used to extract information of interest in various investigations. The following data can be extracted: particle (or void) volume, center of mass, surface area, aspect ratio, long axis orientation; and location, direction, and surface area of all particle-particle contacts.

A series of tests were performed to verify that the information produced by the analysis is correct. Two phantoms consisting of uniform glass spheres in cubic and hexagonal packing were scanned and processed to test the detection and quantification of particle-particle contacts. A third phantom with glass spheres of various sizes was scanned at higher resolution to test the software's ability to deal with varied data, and reproduce the grading of the bead spheres used to create the phantom. In all cases test results met expectations. In addition, insights were gained concerning the level of resolution necessary in CT data for successful discrimination of objects of various sizes.

Product Payoff Potential

The value of this project is in its potential to improve the methods by which pavements are formulated and constructed. These techniques can aid in the formulation of mixing methods by comparing experimentally mixed cores; poor-performing mix designs can be identified and eliminated. Such an analysis can also be used as a forensic tool to evaluate why a pavement has failed. These investigations should allow creation of higher-quality and longer-lasting pavements, with large indirect savings due to reduced requirements for maintenance and replacement. Five hundred million tons of asphalt concrete is laid down each year as overlays, full-depth pavements, and other applications, at a cost of up to \$15 billion. Any incremental savings enabled by improved pavement design should result in considerable savings. Reduced wear on vehicles due to better pavements also constitutes an indirect but potentially large payoff.

Product Transfer

The next stage of development of this technology will take place at the Turner-Fairbank Highway Research Center of the FHWA, where an industrial CT scanner has been procured and installed in order to begin systematic investigation of core samples from experimental mixers and from field tests, such as WesTrack.

APPLICATION OF SHAPE MEMORY ALLOYS IN SEISMIC REHABILITATION OF BRIDGES

NCHRP-IDEA Project 65

Reginald DesRoches [Tel.: (404) 385-082; Fax: (404) 894-0211],
Georgia Institute of Technology, Atlanta, Georgia

IDEA Concept and Product

The proposed research will develop seismic damping devices made of shape memory alloys (SMA) that can be applied to retrofit of bridges. By concentrating energy dissipation in controlled locations, these devices can be used to reduce the demand on individual frames in a multiple-frame bridge, thereby enhancing the performance of these structures. Restrainer devices and composite bearing devices will be developed and tested. Analytical models will be developed to determine the effect of these devices in structures.

Project Results and Planned Investigation

Recent earthquakes have shown that conventional hinge restrainers used in the United States and Japan do not provide adequate protection from unseating, which can lead to collapse of bridges. The proposed research program will study the efficacy of using shape memory alloy restrainers and shape memory alloy based elastomeric bearings to reduce the seismic vulnerability of bridges. Shape-memory alloys are a class of alloys that display several unique characteristics, including Young's modulus-temperature relations, shape memory effects, and high damping characteristics. In most current applications, the temperature-induced phase change characteristic of shape-memory alloys is used. For some SMA, such as Nitinol (NiTi SMA), the phase change can be stress induced at room temperature if the alloy has the appropriate formulation and treatment (Figure 1). Passive energy dissipation devices using shape-

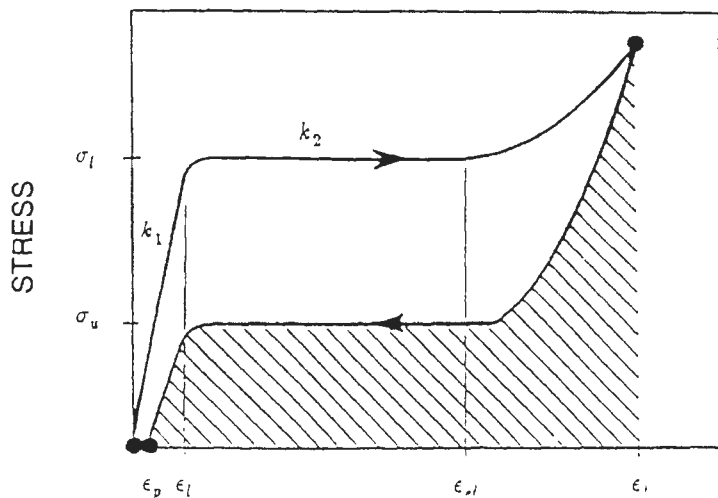

Figure 1

Idealized force-deformation relationship for NiTi shape memory alloy wires

memory alloys have taken advantage of the high damping characteristics of these devices. The proposed research will first investigate using SMA dampers to dissipate energy at the intermediate hinges in a bridge (Figure 2). The dampers will have multiple roles. First, they can limit the relative displacement between frames, thereby reducing the risk of collapse due to unseating of frames at the hinge. Second, by concentrating energy dissipation in controlled locations, these devices can be used to reduce the demand on individual frames in a multiple-frame bridge, thereby enhancing the performance of these structures. The second phase of the study will investigate the performance of SMA-based elastomeric bearings. The SMA-based elastomeric bearings will be constructed and tested to evaluate their force deformation and energy dissipating characteristics (Figure 3).

Product Payoff Potential

There are thousands of bridges in the United States that are in need of seismic retrofit. The state of California alone has spent nearly \$750 million in seismic retrofit since the 1989 Loma Prieta earthquake. Many other state DOT's are now beginning to initiate similar retrofit programs, including New York, Tennessee, Illinois, and South Carolina. Should this technology prove effective and cost efficient, it can become a widely used seismic retrofit technology. Cost/benefit analyses will be performed to compare shape memory alloys with conventional restrainers.

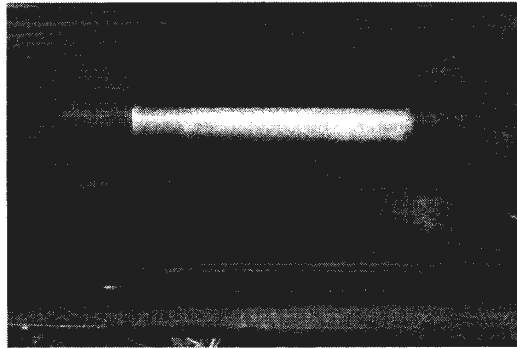

Figure 2

Proposed SMA damper

Product Transfer

Once the technology has been proven effective in reduced-scale experimental tests, the products will be developed and tested in full-scale. Representatives from various DOT's will be provided with the test results and will be invited to participate in future full-scale tests. Collaboration with Shape Memory Alloy manufacturers and end-users is essential to ensure application of the research. The principal investigator will also work with restrainer suppliers/manufacturers to encourage them to invest in this new technology.

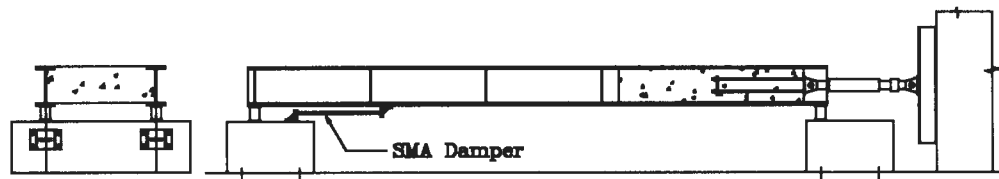

Figure 3

Proposed experimental test setup showing SMA damper connected from bridge deck to concrete pier cap.

DEVELOPMENT OF AN INNOVATIVE CONNECTOR SYSTEM FOR FIBER-REINFORCED POLYMER BRIDGE DECKS TO STEEL STRINGERS

NCHRP-IDEA Project 66

Julio F. Davalos [Tel.: (304) 293-3031, ext. 2632; Fax: (304) 293-7109]
and Karl E. Barth, West Virginia University, Morgantown, West Virginia
and Pizhong Qiao, The University of Akron, Akron, Ohio

IDEA Concept and Product

This project will develop, test, and implement a new connector system to attach fiber-reinforced polymer (FRP) bridge decks to supporting steel stringers. The concept consists of steel top and bottom circular bearing plates with attached grouting cylinders that overlap snugly. The steel sleeves are installed through pre-drilled holes in the deck, and the bearing plates are bonded to the deck surfaces using a durable adhesive (e.g., high-performance polyurethane). The proposed prototype connector will be developed using a honeycomb FRP deck design manufactured by Kansas Structural Composites Inc. (KSCI), but its future application can be extended to other cellular FRP decks. The deck panel with pre-installed steel sleeves will be placed over steel stringers fitted with steel studs, similar to those used for concrete slabs. Then the holes will be injected with expansive grout (or polymer concrete), and the top bolt will be tightened against the washer resting over the bearing ring of the top sleeve; a simple cap can then be placed to cover the hole. (The dimensions and details of the connector are being designed through an optimization program as part of this project.) The connector will be tested under cyclic and ultimate load, and several design concepts will be evaluated including failure mode, degree of composite action, and load distribution. Following the completion of the present project, this connector system will be field-evaluated in collaboration with the West Virginia Dept. of Transportation, Division of Highways, and possibly also Kansas DOT.

The proposed concept was conceived by combining the benefits offered by conventional stud connectors for steel/concrete and specialized shear-plate connectors for wood structures. The major five benefits of the proposed concept are as follows: (1) Structural Efficiency—This connector can minimize shear and compressive stresses in the composite; these stresses are critical in design of FRP materials. (2) Ease of Installation—Since the connector's sleeve is installed at the fabricator's shop, and the technology of welded stud connectors is well established, the installation of the deck would be simple and quick. (3) Ease of Replacement—In case of replacement and/or reuse, the grouting material can be cut off the deck with a simple core boring drill. (4) Versatility of a "Universal" Connector—This concept can be applied to a variety of FRP deck geometries, including pultruded sections and "sandwich" panels. (5) Cost Benefit—The simplicity of the concept and the reduction of field-installation efforts make this connector attractive and cost-competitive for application to a broad range of FRP bridge decks.

Project Results and Planned Investigation

The project has been organized in three stages: (1) Design and Optimization, (2) Analytical/Experimental Evaluation, and (3) Performance Evaluation of the Connector System.

Stage 1: For design purposes, an engineering approach will be first used to approximately define the dimensions of the connector system in relation to the expected loads and deck and stringer dimensions. Then, the preliminary design will be modeled and analyzed using a Finite Element (FE) program, ANSYS (see Figure 1, FE analysis of face sheet hole for optimal diameter study of the connector). Based on FE parametric studies, the connector will be optimized using a global approximation technique and a multi-objective optimization scheme developed previously by Davalos and Qiao, members of the research team.

Stage 2: The connector design will be experimentally evaluated by first testing a single connector between a section of FRP deck and a steel wide-flange beam. The ultimate strength of the connector will be evaluated through push-out tests, and the two parameters examined will be the inside diameter of the connector sleeve and the grout in-fill material. Based on the optimum combination of these two parameters, a series of cyclic load tests will be performed to monitor the fatigue stiffness and strength reductions. In this phase of the project, the deck-to-stringer connection response will be modeled and evaluated using the FE program, ABAQUS. The experimentally validated FE model (Stage 3) will be used to predict other configurations not tested in the laboratory.

Stage 3: Finally at the system level, the performance of the connector-stringer design will be evaluated for fatigue degradation under multiple loading cycles, number of required connectors for adequate deck restraint, percent of composite action, and effective flange width for the deck/stringer system. The results of the FE model from Stage 2 will be correlated with some of the laboratory test results obtained.

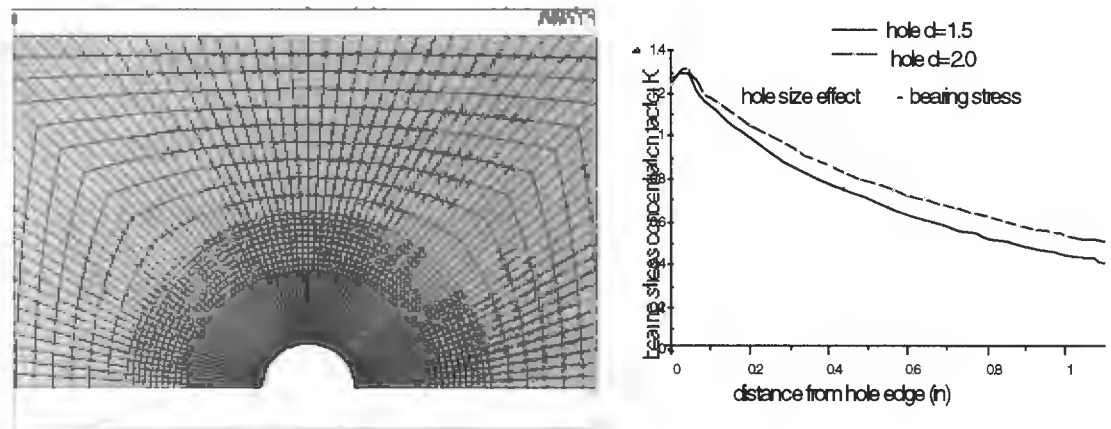

Figure 1

Finite element modeling and bearing stress concentration distribution at composite face sheet

Product Payoff Potential

FRP bridge decks offer several favorable advantages for bridge construction and particularly rehabilitation projects. Their lightweight, high strength, and non-corrosive characteristics makes them suitable for bridge deck applications. In addition, FRP bridge decks can be manufactured as modular “off-the-shelf” components for rapid installation as new structures and replacement of existing conventional decks, such as concrete. Moreover, FRP decks can be manufactured with built-in sensors, such as fiber optics, for monitoring and even intelligent response.

In the last five years, and after KSCI successfully installed a short-span bridge in Russell County, Kansas, several research-industry-government teams have demonstrated the feasibility of field applications of FRP decks and bridges for relatively short-spans. Based on cost considerations, it is likely that most FRP structural components will be manufactured from low-cost fibers (E-glass) and resins (Epoxy, Vinyl-ester). But due to the low stiffness of these materials, the major technological and economical potential impact of FRP decks is their installation over steel or concrete stringers for new and retrofit construction of highway bridges. A key problem that requires resolution is the connection of the FRP deck to the supporting stringers; this very important problem is the concern of this project. The KSCI honeycomb FRP deck will be used to develop the prototype connector, which will be adaptable as a “universal” connector for any other cellular FRP deck

Product Transfer

Following the successful development and evaluation of the proposed connector, investigators will work closely with the WVDOT and KDOT to implement this concept in future bridge projects. In particular, the WVDOT is in the process of implementing a large-scale program for several demonstration bridges in West Virginia using high-performance materials, including high-strength steels (70 and 100 Ksi) and FRP deck systems. Thus, the WVDOT is very much interested in the immediate implementation of this connector design in order to rapidly advance the effective applications of FRP bridge decks.

ALL COMPOSITE BRIDGE SIDEWALK

NCHRP-IDEA Project 67

D. Thomson [Tel.: (781) 622-5505; Fax: (781) 890-0488]
and T. Campbell, Foster-Miller, Inc., Waltham, Massachusetts,
and G. E. Johansen, E.T. Techtonics, Inc., Philadelphia, Pennsylvania

IDEA Concept and Product

Population growth, and the subsequent obsolescence of infrastructure components such as bridges, results in an ever increasing conflict between safe and convenient traffic flow and the desire to maintain current aesthetics. With these aging bridges often already posted, there is no dead load weight budget for a standard steel and concrete sidewalk. The opportunity exists to address a significant component of this problem through the use of advanced composites to construct lightweight, maintenance free bridge sidewalks. Foster-Miller, teamed with E.T. Techtonics (ETT), is designing and demonstrating an all-composite cantilevered sidewalk system for retrofit installation on steel girder highway bridges. The design configuration consists of composite I-beams which attach directly to the bridge fascia beam and extend laterally as the cantilevered support. The sidewalk superstructure is a version of ETT's well proven composite pedestrian bridge. This superstructure will lie directly on top of the cantilevered I-beams. The complete modular system can be delivered pre-assembled to the site for rapid, cost-effective installation.

Project Results

The Foster-Miller team has defined the loading and performance requirements through several discussions and meetings with personnel from the Vermont Agency of Transportation (VAOT) and other New England DOTs. Based on these requirements, a carbon fiber-reinforced composite I-beam was designed and fabricated for the cantilevered support. One of the fabricated beams is shown in Figure 1.



Figure 1

Foster-Miller carbon composite I-beam

This I-beam is 18 inches deep, 11 feet long and weighs only 128 pounds. It was designed to support a sidewalk subjected to an 85 pounds per square foot (psf) live load with a deflection limit of $L/300$. The overall design load condition added the pedestrian load to a 100-psf snow load with a factor of safety of three. Recently, it was successfully tested to this design condition of 16,650 pounds, and further to 21,200 pounds. The ultimate load condition exerted more than 125,000 foot-pounds at the cantilever connection point. The test also verified that the design met the deflection limit. A long-term creep test of a second beam is also being conducted.

The sidewalk superstructure is an adapted version of team member E. T. Techtonics well proven pedestrian bridge technology. A truss design similar to the bridge shown below will be used (Figure 2). ETT is finalizing the superstructure design. This structure will be fabricated from standard fiberglass pultruded sections and will be pre-assembled in the factory and delivered to site in units up to 40 feet long, depending on local site conditions.

Product Payoff Potential

The proposed development was put forth by Foster-Miller as a direct result of a significant need expressed by several transportation agencies. Composite sidewalks can provide numerous advantages including the following:

- *Enable sidewalk installation* where standard steel and concrete construction is too heavy for retrofit of the existing bridge.
- *Permit road widening* within the existing bridge envelope by moving existing sidewalks outboard.
- *Reduce impact* of cantilevered sidewalks as low weight minimizes the need for extensive build-up of the existing bridge structure.
- *Minimize maintenance* through use of non-corroding materials.

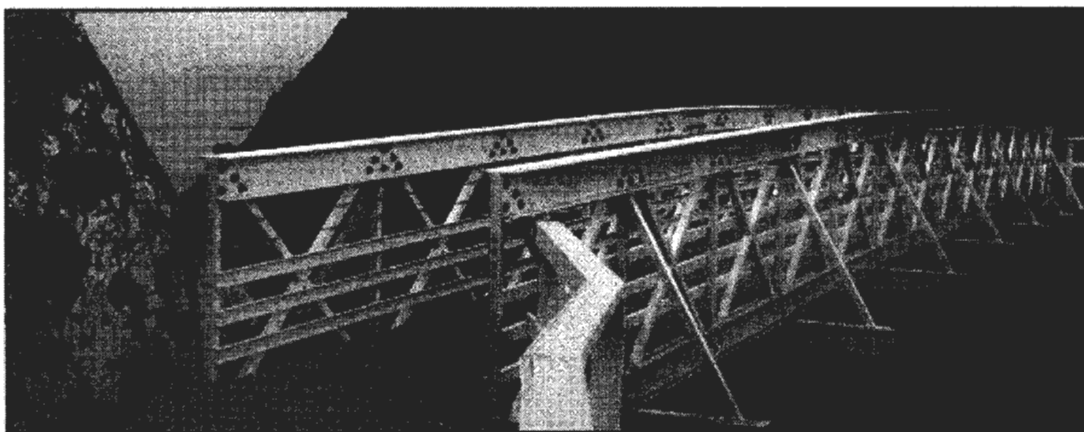

427-P-98595-7

Figure 2

E.T. Techtonics composite pedestrian bridge

Product Transfer

This Type 1 IDEA program is providing the seed funding necessary to complete full-scale laboratory demonstration of the key elements of the cantilevered sidewalk system. Several potential installation sites have been identified through the initial discussions based on the advantages cited. The Vermont Agency of Transportation (VAOT) has selected the first demonstration site on a 240-foot long steel girder, concrete deck bridge. Initial plans are in place to install the all-composite sidewalk on this bridge in the summer of 2001. Foster-Miller and the VAOT are discussing the project and potential funding sources. Foster-Miller will also pursue Type 2 IDEA program funding to support some aspects of the project. Foster-Miller is also pursuing additional sites in the Northeast as several state agencies have expressed strong interest in the project.

GEOCOMPOSITE CAPILLARY BARRIER DRAIN FOR LIMITING MOISTURE CHANGES IN PAVEMENT SUBGRADES AND BASE COURSES

NCHRP-IDEA Project 68

John Stormont [Tel.: (505) 277-6063; Fax: (505) 277-1988],
 University of New Mexico, Albuquerque, New Mexico
 and Karen Henry, US Army Cold Regions and Research Engineering Laboratory,
 Hanover, New Hampshire

IDEA Concept and Product

The Geocomposite Capillary Barrier Drain (GCBD) is a new method for removing water from pavement systems. In contrast to conventional drainage systems, a GCBD will interrupt, divert, and drain water from pavement soils and aggregate layers when they are unsaturated, resulting in less water in the pavement system than conventional drainage methods leave. A GCBD consists of a geonet sandwiched between two geotextiles (Figure 1). The geonet serves as a capillary barrier, effectively blocking downward or upward unsaturated flow. The geotextiles are specially designed to be conductive to water in unsaturated conditions. In this

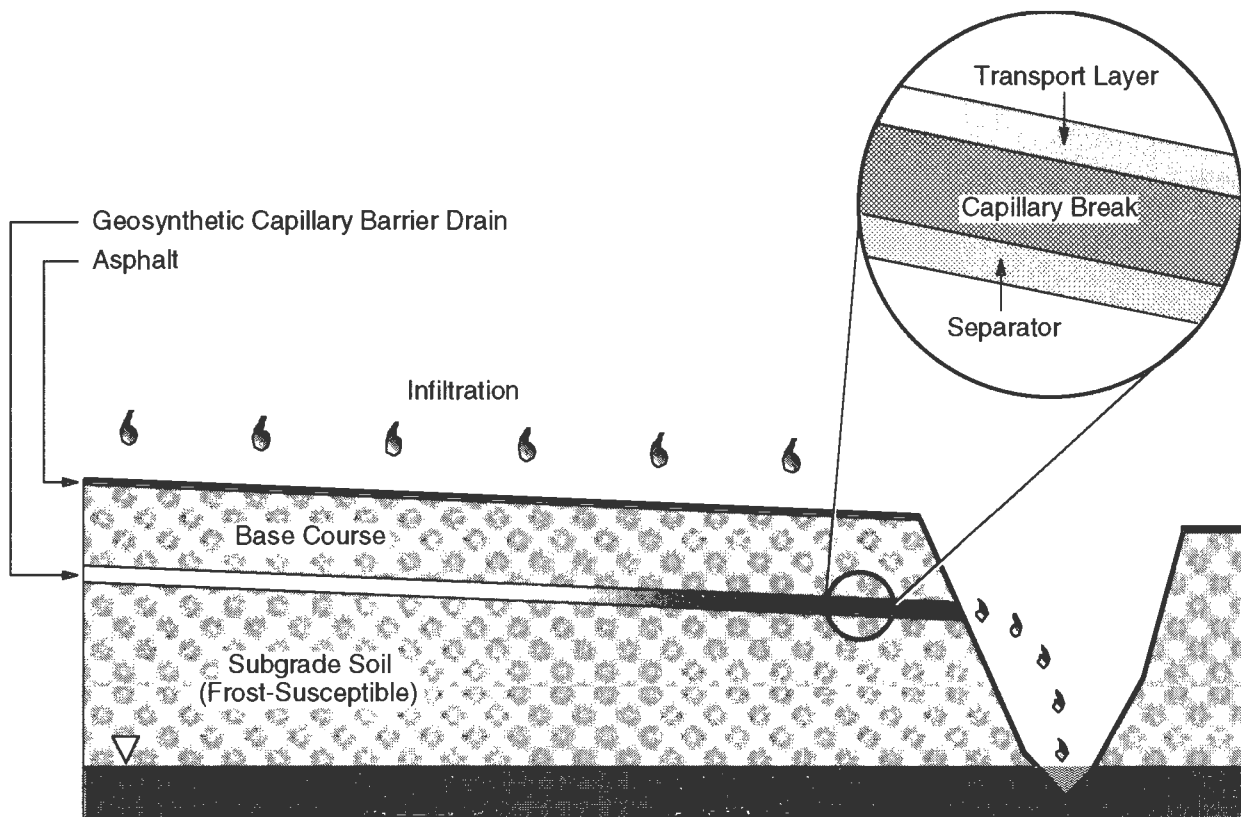

Figure 1

Schematic of Geocomposite Capillary Barrier Drain concept.

way, the geotextiles can soak up water from the adjacent soils and laterally drain it before those soils reach saturation. A GCBBD placed between a base course and sub-grade will thus prevent positive water pressures from developing in base course and protect underlying sub-grade material from water content changes. A GCBBD will also interrupt upward capillary flow that can supply water to overlying frost-susceptible layers. The GCBBD, then, will reduce the amount of water in pavement systems and consequently reduce problems related to water.

Project Results

The research is being conducted in two stages. The objective of Stage 1 (completed in 2000) was to select the best possible transport layer for a GCBBD system from available materials. In Stage 2, water movement and drainage within a full-scale pavement section with and without a GCBBD system are currently being evaluated.

Stage 1: Initial evaluation of the GCBBD concept verified that GCBBD effectiveness is closely related to the unsaturated hydraulic properties of the geotextile transport layer. In particular, the transport layer should be transmissive under as wide a range of suctions as possible while having a reasonable expectation for longevity in a sub-surface environment. Numerous candidate geotextiles were evaluated in a series of tests, including capillary rise, moisture retention function measurements, siphoning and transmissivity under suction. These test results reveal that geotextiles fabricated from materials such as fiberglass have a substantially greater ability to drain water under suction compared to conventional geotextiles composed of polypropylene and polyester. From these results, a multifilament, woven fiberglass geotextile denoted as TGLASS was selected as the best available material for a transport layer.

To confirm the expected performance of the TGLASS material as a transport layer, a GCBBD with a TGLASS transport layer was placed above a silty sand subgrade and below a gravel typically used as a base course in a 3-m-long sloped test device used to measure lateral drainage. Water was infiltrated first at a constant rate and then in simulated transient design storms on the top of the base course. Drainage from the GCBBD and the soil layers was collected, and measurements of soil suction were made within the soil layers. Test results, summarized in Figure 2, show how drainage from the GCBBD lowers the saturation of the base course material, preventing complete saturation and positive pore water pressures from developing in the base course. Further, the GCBBD drainage capacity was sufficient to limit water movement into the underlying sub-grade soil. The range of suctions over which the GCBBD drained water from unsaturated soils was increased substantially over that of previous trial GCBBDs that utilized polyester and polypropylene transport layers. These results imply that soils can be drained to much lower saturations with a GCBBD that utilizes a TGLASS transport layer.

Stage 2: The objectives of stage 2 testing (currently ongoing) are to determine whether a GCBBD significantly reduces the saturation time and/or the degree of saturation of a base layer and protects the subgrade compared to a control test section of a road typical of state secondary roads and at infiltration rates that typically occur in the Northeastern United States. A water table is present in the subgrade for these tests.

A waterproof box approximately 1.2 m (4 ft) deep by 1.2 m (4 ft) wide by 6.4 m (21 ft) long has been constructed, and a lane of “typical” pavement was placed inside the box. There is an unpaved shoulder area and a ditch outside of the pavement edge. The box is instrumented to monitor the water table location and soil suction throughout the subgrade and base layers. The

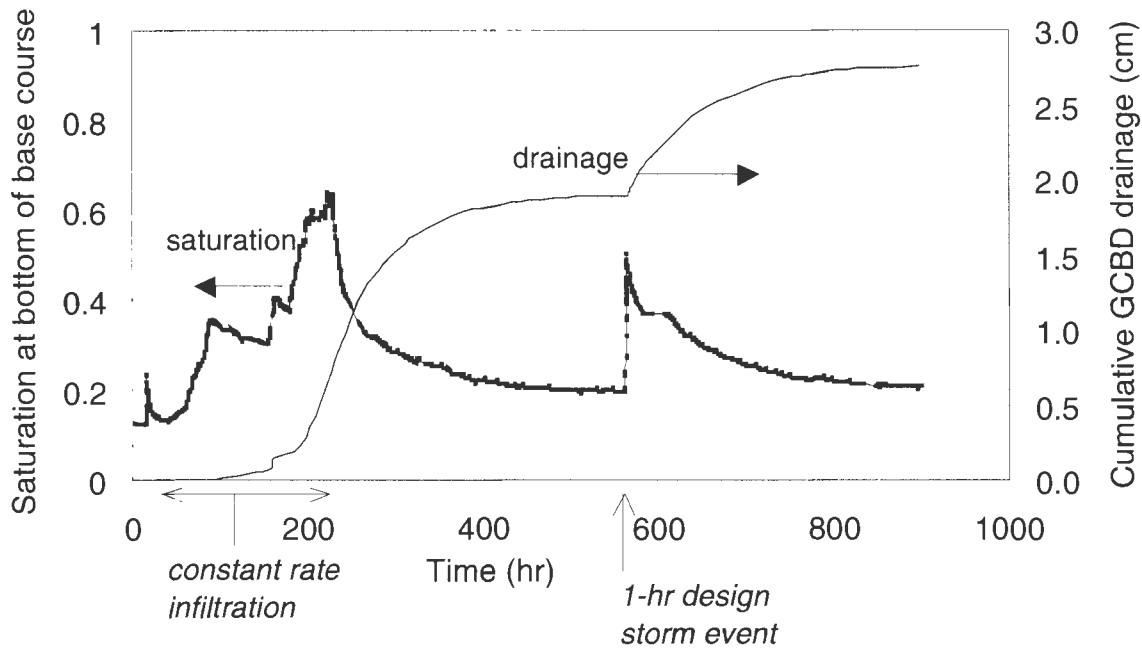

Figure 2

Base course saturation and GCBDrainage during infiltration testing.

parameters varied in the stage 2 testing will be pavement configuration (i.e., whether the pavement test section contains a GCBDrainage) and type of infiltration event. The experimental responses being measured are the quantities and flow rates of water out of the base course, transport layer, capillary barrier layer and the amount of surface run-off.

Product Payoff Potential

The problems associated with excessive moisture in pavement base courses and subgrades are numerous and well known. The use of the GCBDrainage will reduce the amount of water in pavement sections, and thus will improve pavement longevity and quality. Continued testing and evaluation will quantify GCBDrainage performance for different climatic conditions and pavement designs, and permit direct assessment of the value of including a GCBDrainage in a pavement section.

Product Transfer

State transportation agencies from New York, Vermont, and New Hampshire are involved in the planning and conduct of the research program, consequently, their needs and issues are being addressed. Typical pavement materials specified and provided by these states are being used in the research. Furthermore, they will have the opportunity to coordinate implementation of these results via trial test sections based on the outcome of this research. Discussions have begun with a number of geosynthetic manufacturers regarding commercialization of GCBDrainages.

DEVELOPMENT OF A CONDUCTIVITY SPECTRUM PROBE (CSP) FOR PREDICTING CHLORIDE PERMEABILITY IN CONCRETE

NCHRP-IDEA Project 69

Kenneth R. Maser [Tel.: (781) 648-0440; Fax: (781) 648-1778],
INFRASENSE, Inc., Arlington, Massachusetts

IDEA Concept and Product

Both reinforced and pre-stressed concrete can deteriorate because of ingress of aggressive substances such as sulfates, acids, and chlorides present in the environment. However, permeability of concrete to chlorides and other destructive material has not been used in the design and construction specifications mainly due to its difficulty of being quantified.

The prediction of chloride penetration in concrete using current methods is slow and unreliable, and cannot be implemented on in-place concrete. In order to address these limitations, a new method based on the use of a conductivity spectrum probe (CSP) is proposed. The probe, shown in Figure 1, is a surface contact device that can measure both the conductivity and dielectric permittivity of a material over a specified range of frequencies. The measurement can be made either in-place or on samples removed from the structure. The CSP does not require exposure of the sample to any ionic solutions that may react with the concrete. Samples do not have to be fully saturated, since the measured conductivity can be normalized to 100% saturation using the dielectric permittivity data. The use of a range of frequencies allows for variation in the depth of influence of the probe, which can be used to adapt to field conditions and to the presence of reinforcement. The CSP is applicable to the evaluation of newly constructed concrete as well as to concrete that has been in service. The technology for making the measurement is currently available and ready for use in this application.



Figure 1

Conductivity spectrum probe

Project Results and Planned Investigation

The proposed program will involve experimentation and data evaluation using a prototype CSP. A significant participant in the program is W.R. Grace Co. Inc., of Cambridge, Massachusetts who will make an extensive range of laboratory samples available for testing. Preliminary testing of the CSP has been carried out using test samples (shown in Figure 2) using an available network analyzer. Typical data generated by the probe is shown in Figure 3. Based on these tests, a detailed experimental plan will be formulated to represent a range of concrete formulations, rebar configurations, and chloride exposures. Samples representing these conditions will be identified in the W.R. Grace laboratories, and data will be collected on these samples using the CSP. This data will be correlated with the chloride permeability as determined independently from standard tests.

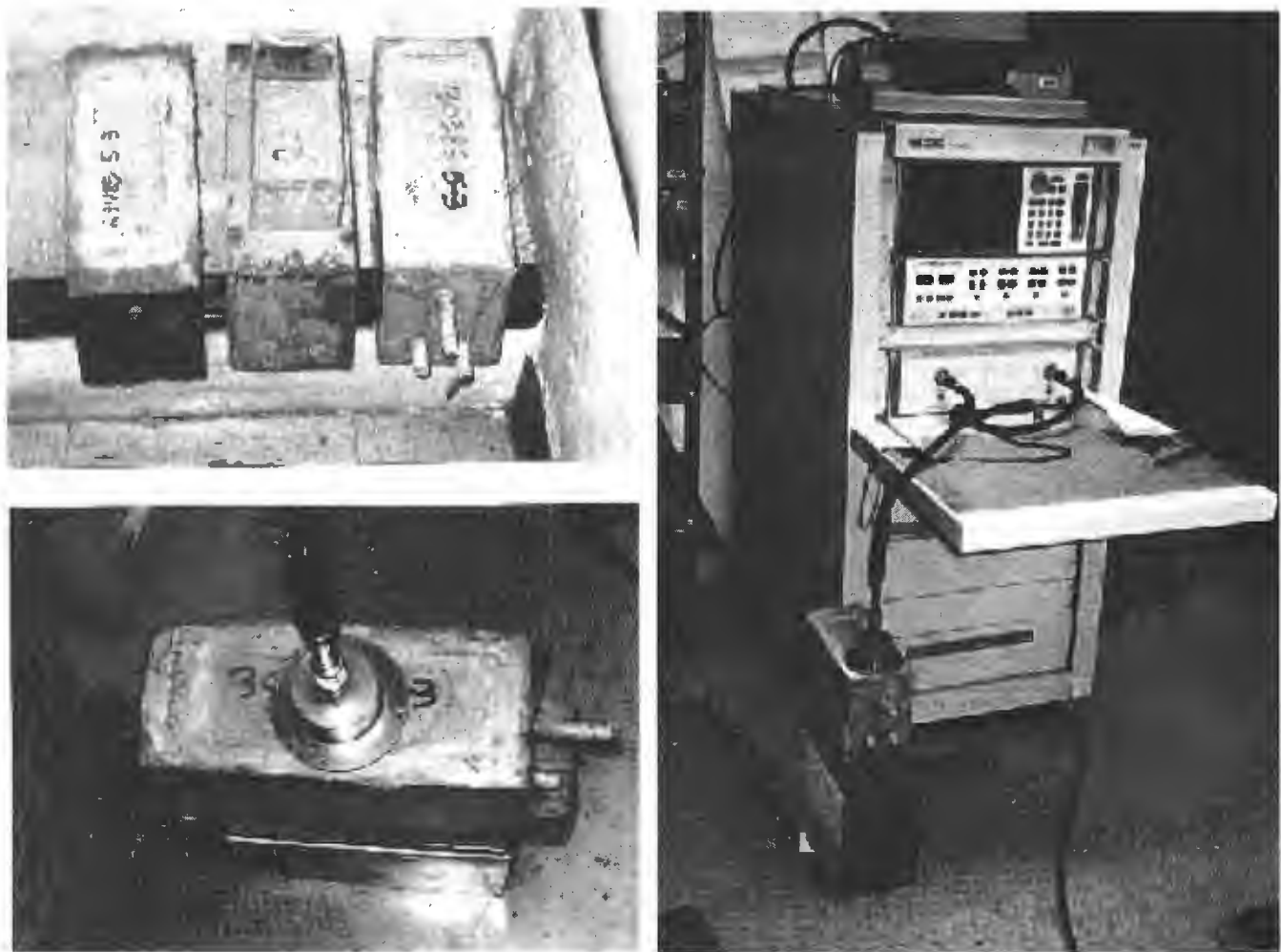

Figure 2

Preliminary testing of concrete samples using the CSP:

(a) samples, (b) testing, and (c) overall setup with network analyzer

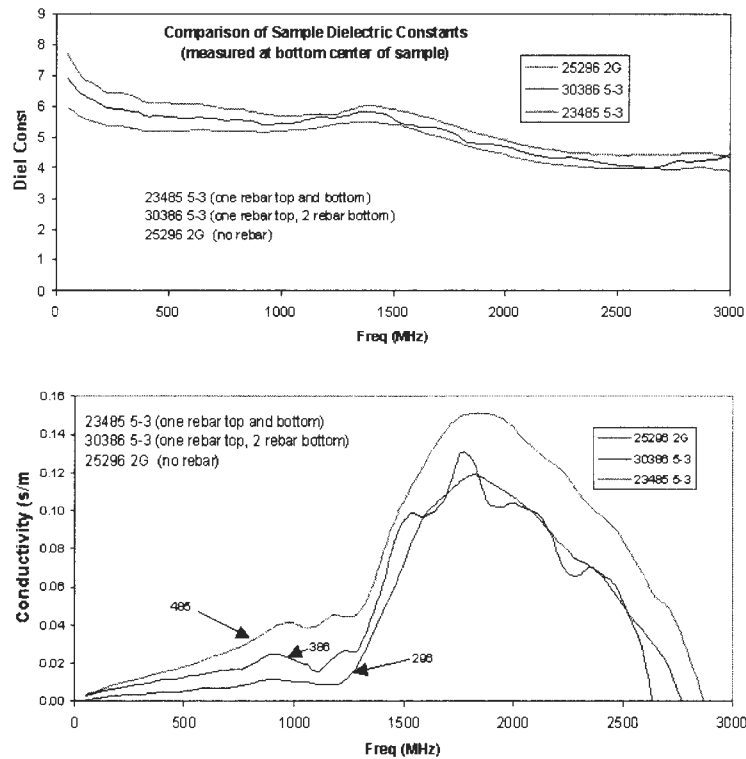

Figure 3

Typical data generated by CSP

Product Payoff Potential

The potential payoff of the proposed CSP could be substantial. According to a SHRP report, about \$450 to \$500 million per year can be saved by correcting corrosion problems in existing bridges. The availability of a simple test such as the CSP, to be implemented at the time of construction, will go a long way to ensure that concrete that is put into service is adequately resistant to chloride permeation. The market for the CSP will be state and local highway agencies, construction contractors, and consulting and testing organizations. Commercial applications for the technology include all construction, including highways, bridges, buildings, and other concrete construction where exposure of concrete to chlorides and other aggressive materials is of concern.

Product Transfer

Once the concept is successfully demonstrated in Phase I, the Phase II program will focus on the design, development, and evaluation issues related to development of a pre-production prototype. As part of Phase II, *INFRASENSE* plans to develop a strategic alliance with an organization or organizations that are well positioned to sell equipment to the construction and testing industry. There are a number of such firms, any one of which could serve as a potential distributor for the CSP.

FLAMESPRAY COATING AS AN ENVIRONMENTALLY ACCEPTABLE PAVEMENT MARKING TECHNIQUE

NCHRP-IDEA Project 70

Anthony L. Andrady [Tel.: (919) 541-6713, Fax: (919) 541-8868],
Research Triangle Institute, Durham, North Carolina

IDEA Concept and Product

The project proposes to use novel polymer systems flamespray coated onto asphalt (and concrete) pavements as a cost-effective and environmentally compatible pavement marking system. While used extensively in bridge maintenance, the novel polymer resins proposed here have never been tested as flamesprayed pavement marking materials. The approach has the advantage that a wide range of plastic materials is available for use, allowing a higher degree of control over adhesion (and durability) on pavement surfaces. It will also be a quick drying "no cone" striping system requiring a minimum disruption of traffic during the application

Planned Investigation

The objective of the proposed work will be to demonstrate that suitable powdered thermoplastic resins can be flamesprayed on asphalt pavement surfaces to obtain a marking system that is comparable or superior in performance to the extruded thermoplastics now in use.

Evaluation of the amenability of conventional thermoplastics (alkyd and hydrocarbon type) to flamespraying will be of primary interest as this allows the most convenient route to flamespray pavement marking. In addition to these conventional resins, alternative thermoplastic resins that might be used for flamespray application onto asphalt will also be evaluated.

Particle size studies and grinding technique studies to identify appropriate plastic substrates for the flamespray process will be included in the investigation. As oversized particles will not melt adequately and those too small tend to pyrolyze in the propane flame, it is important to obtain a narrow distribution of resin particle sizes. In some instances a broad particle-size distribution might be compensated for by pre-heating the substrate. With asphalt surfaces, only minimal pre-heating (at best to dry the surface) is feasible. Selection of the optimum particle size that allows a smooth flow of impacting droplets and enables facile coalescence is therefore critical for success.

In the course of the investigation a series of test coatings will be prepared using the novel resin formulations along with the flamespray technique. These will be tested for durability and appearance against standard striping used in the industry. A multi-attribute analysis will be carried out, based on a published methodology, to evaluate the environmental compatibility of the flamesprayed coatings to be developed here. An additional analysis task would be to assess the emission of volatile organic compounds from the coating, particularly during the application process. Preliminary field studies to quantify the emissions from this technology are also planned.

Product Payoff Potential

The development of an inexpensive and high-performance (both engineering and environmental performance) pavement marking system will have a major impact on the industry. With about 80 percent of the markings still based on conventional or water-based traffic paints, conservative estimates place the VOC load released to the environment from the centerline markings alone to be over 39 million pounds per year. While switching over completely to water-based paints can reduce this load anywhere from 50-90 percent, the presence of hazardous airborne pollutants (e.g., methanol) will remain a significant concern. Some sacrifice in performance and an investment in equipment redesign is usually involved. Switching from paints to dry-powder systems will enormously benefit the industry that annually maintains nearly 800,000 miles of the nation's highways. Even a partial conversion to these novel resins can provide an inexpensive avenue for the pavement marking community to address environmental regulations and also very significantly reduce worker inhalation of hazardous chemicals.

Product Transfer

The key deliverable from the proposed effort is the identification of appropriate thermoplastic resin materials that are best suited for pavement marking, and a demonstration of their ability to be flamesprayed using state-of-the-art equipment. Findings from the study will be reported to the IDEA Program and will also be published in journals commonly read by the pavement marking community. Investigators will endeavor to provide users with demonstrated technical feasibility of approach, a techno-economic justification for using the new marking system, and the identity of equipment and resin groups best suited for the application. In addition to the print media, a web site is proposed that will be linked to the NCHRP home page to disseminate information and to promote discussion of the new technology developed as a part of the project. Provided a suitable corporate sponsor can be found, data and demonstration material will be presented at the American Traffic Safety Services Association (ATSSA) annual convention.

IMPLEMENTATION OF TUNED DAMPERS FOR SUPPRESSION OF BRIDGE STAY CABLE VIBRATIONS

NCHRP-IDEA Project 71

Armin B. Mehrabi [Tel.: (847) 965-7500; Fax: (847) 965-8997],
Construction Technology Laboratories, Inc., Skokie, Illinois,
and Habib Tabatabai, University of Wisconsin, Milwaukee, Wisconsin

IDEA Concept and Product

Feasibility of a new concept for improved design- or retrofit- stage control and suppression of bridge stay cable vibrations was explored and demonstrated in an earlier IDEA project (NCHRP IDEA Project 50). It was concluded that the tuned mass damper (TMD) concept promises an advantageous alternative when compared to available damping measures. The objective of this proposed product application research is to design, fabricate, and demonstrate on a cable-stayed highway bridge structure that tuned mass stay cable dampers would increase cable damping ratios to levels beyond the threshold of vulnerability to rain-wind induced vibrations. In TMD concept, a mass is attached to the cable through a viscoelastic spring/dashpot system. The proposed device consists of a viscoelastic element (spring/dashpot) contained between an outer cylinder (mass) made of steel or similar material and an inner cylinder (the cable). The viscoelastic element can be formed in various shapes to achieve the desired spring constants. The ends of the outer cylinder can be sealed using neoprene boots, and the mass of the cylinder can be designed to match the frequency of the cable and theoretically placed at any point along the length of the cable. Figure 1 shows a schematic of the TMD to be implemented.

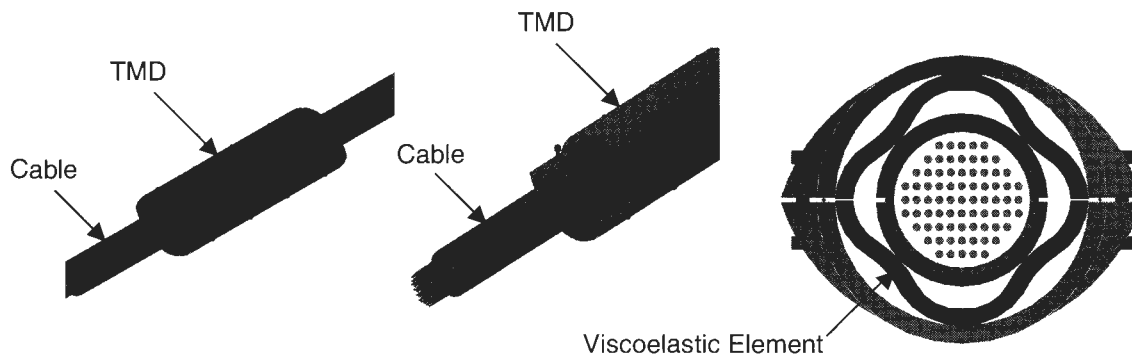

Figure 1

Schematic of tuned mass damper (TMD) system.

Planned Investigation

The program will comprise four phases: (1) full-scale tuned mass damper design development, constituent materials and component selection; (2) materials and component procurement/fabrication and damper prototype assembly; (3) confirmation of theoretical damper response characteristics in structural laboratory and at bridge site; and (4) documentation of development results and support for technology transfer to the highway community and construction industry.

Initial steps for the applied development program involve partnering with interested highway organizations and individuals from the NCHRP Project 50 Expert Review Panel. Tasks include establishing cost-share agreements, design, and industry participants, selecting candidate bridge sites, developing cable size criteria for prototype dimensions, communicating with the FHWA pooled-fund study team, and project management tasks. The success of the project relies on not only overcoming technological challenges of successful fabrication of a prototype but also assuring that a suitable, viable site is available for demonstration and verification.

Product Payoff Potential

Based on an analysis of data in Construction Technology Laboratories' database of stay cable information from 19 bridges around the world, it was concluded that a great majority of cables are susceptible to the sort of large-amplitude vibration studied by the researchers. Presently, it is industry practice to attempt resolution of vibration problems by adding mechanical dampers or cross cables (secondary cables). These retrofit procedures can be costly and not completely effective. On the other hand, not taking any steps to address the problem may result in long-term fatigue endurance issues, especially at anchorages. Full-scale prototypes are expected to be a low-cost, low maintenance vibration control option that can be applied to both existing and new stay cables. Compared to conventional viscous dampers or other alternatives, the TMD offers a higher efficiency, lower cost, no positioning limitations, smaller size, low maintenance, and better aesthetics. It is believed that the tuned mass damper concept can be developed successfully into a marketable product.

Assuming that the current rate of cable-stayed bridge construction is maintained, it is anticipated that a total of 40 major cable-stayed bridges will exist in the United States by the year 2006. Assuming that an average bridge has 100 cables and 60 percent of those cables require improved damping, then a US market of roughly 2,400 units will present itself. Limited use has been made of common viscous dampers for vibration suppression, and these are priced in the vicinity of \$8,000 to \$12,000 each, including installation. Technologically, present cable-stayed bridge maintenance strategies strongly advocate cable vibration suppression. This trend is expected to continue as a new design feature for yet-to-be constructed bridges. Thus, one can estimate that the potential value of the US market is in the range of tens of million dollars. The global market for such damping devices overshadows the US market by an order of magnitude. Market position of a less costly, more easily installed cable damper is considered attractive to prospective manufacturers.

Product Transfer

It is proposed that a prototype TMD system be developed, installed, and evaluated on one or more stay cables of a bridge exhibiting rain-wind vibration susceptibility. In preparation for technology transfer and implementation, detailed analytical work will be performed to prepare design charts for selection of damper size and locations. Durability aspects of the prototype damper would also be another area deserving consideration.

Collaboration with state and federal transportation organizations and leading bridge designers will foster implementation of the innovation. The research team has been and is involved in evaluation of several cable-stayed bridges. One or more of these bridges will be retrofitted with mechanical viscous dampers for suppression of excessive vibrations in near future. These bridges could potentially be used to test the TMD prototype. It is proposed that cable vibration measurements be taken for a period of at least 2-3 months before and after installation of damper. Such monitoring is currently planned at least for one bridge. The recently initiated FHWA pooled-fund study assessing cause and potential solutions to the rain-wind vibration issue may also present opportunities for selection and implementation of prototype validation settings. At this point, one prominent stay cable manufacturer, the Federal Highway Administration, the HNTB pooled-fund study research team, and the state of Alabama have expressed strong interest in advancing commercial development of these dampers. It is expected that, if and when contacted, other such industry partners would also express interest.

IMPROVED FILTRATION OF WASH WATER GENERATED DURING BRIDGE MAINTENANCE PAINTING

NCHRP-IDEA Project 72

Vickie Ainslie [Tel.: (404) 894-3988; Fax: (404) 894-2481]

and Robert Lewallyn, Georgia Tech Research Institute, Atlanta, Georgia
and Theodore Hopwood, Kentucky Transportation Center, University of Kentucky,
Lexington, Kentucky

IDEA Concept and Product

Many state highway agencies now perform bridge maintenance painting by overcoating the existing paint. This method is used to minimize the possibility of releases of hazardous materials into the environment and provides a lower initial cost compared to maintenance painting operations that incorporate complete removal of existing paint by abrasive blasting (with containment). Typically, overcoating entails pressure washing to remove soils, bird droppings, chalk, or weakly bonded paint. The resulting wastewater often contains lead paint chips that can be partially removed by mechanically filtering the water through porous containment screens. Mechanical filtering is ineffective in removing micron-sized particles that result from chalked or brittle paint removed by pressure washing. The total lead content of the wastewater ranges anywhere from 50 to over 1,000 ppm after mechanical filtering, far in excess of the 15 ppb allowed in drinking water. State highway agencies are facing increasingly more restrictive regulations regarding the disposal of lead-contaminated wastewater generated by pressure washing operations.

The goal of this project is to develop an improved filtration system for removing both particulate and soluble lead from wash water generated by pressure washing lead-based paint from highway bridges prior to maintenance painting operations by overcoating. The filtration system will use a granular compound capable of chemically binding free lead into an insoluble lead mineral. Naturally occurring sulfate-based and phosphate-based rocks are known to immobilize lead to varying degrees. Proprietary compounds have also been developed to immobilize lead. This project will first test various compounds (both natural and proprietary) to identify suitable compounds for use as the filter media in stabilizing lead. Then a prototype filtration system will be developed and tested on an actual bridge maintenance overcoating painting operation.

Planned Investigation

The proposed project will evaluate the efficacy of a filtration system for reducing the level of soluble lead in wash water. A four-phase experimental program is planned, consisting of laboratory, prototype, field implementation, and commercialization phases. The Georgia Tech Research Institute will conduct the initial laboratory phase to evaluate several compounds for their suitability as a filter media.

Testing will consist of a series of bench-scale trials designed first to establish the effectiveness of various lead-stabilizing compounds in removing lead in wash water, and second, to evaluate optimum compound-to-wash water ratio, contact time, flow rate, service life, and other data needed for full-scale filter system design. In the prototype phase, a prototype filter system will

be designed and constructed for preliminary evaluation by the Kentucky Transportation Center at the University of Kentucky. Additional filter systems will also be prepared for use in the field implementation phase, taking into consideration the lessons learned from evaluating the prototype. In the field implementation phase, the new filter system will be evaluated by processing wash water from an actual bridge overcoating project in Kentucky. If necessary, modifications will then be made to the filtration system in preparation for full-scale deployment of the technology. The commercialization phase will consist of disseminating the field test results through a variety of prominent forums, seeking patents, and identifying a manufacturer for the filter system.

Product Payoff Potential

The proposed filtration system would provide substantial cost savings compared to traditional water treatment systems. Hundreds of steel bridges are painted each year using overcoating. Many state environmental regulatory agencies currently require wash water generated on such projects to be treated to lower lead levels and may also require off-site disposal into sanitary sewers and more restrictive regulations are anticipated to be established in states that do not currently have such requirements. The use of the new filtering system would permit direct discharge into receiving waters (streams, rivers, and wetlands), permitting significantly reduced bridge painting costs. Savings could range from \$5,000 to more than \$1,000,000 depending on project-specific factors—bridge size, location, regulatory requirements, availability of sewer system, etc. An estimate of savings to bridge owners nationwide would be on the order \$1,000,000 to \$5,000,000 annually. Additional savings would accrue to bridge owners who would select overcoating rather than the more costly methods of complete paint removal by abrasive blasting or chemical stripping due to more favorable lifecycle costs. These savings might prove to be in the same range (\$1M to \$5M). Because of its simplicity and its expected effectiveness, the proposed filtration system would provide bridge owners with a new “best practice” for reducing the discharge of lead into streams, rivers, and wetlands, and has a high probability of becoming an EPA-accepted “best available technology” and the standard procedure for in-process wash water filtration.

Product Transfer

Following successful field implementation, the program partners would actively disseminate the project findings to highway agencies throughout the United States. KTC researchers are confident that additional state highway agencies can be involved in the implementation and testing process. The Kentucky Department of Highways (KYDOH) will specify the routine use of the filter system on bridge maintenance painting projects within the state as part of the agency’s commitment to employ “best practices” to safeguard the public and the environment.

After the successful completion of the fieldwork, the test results would be widely disseminated through a variety of forums. KYDOH and KTC personnel would report the test results at prominent user meetings such as the Western Pennsylvania Engineer’s Society Annual International Bridge Conference, the Society for Protective Coatings [SSPC] Annual International Conference and Symposium, the National Association of Corrosion Engineers [NACE] Annual Conference & Exhibition and Mid-American Trade Show-Corrosion Control, the U.S. Navy & Industry Corrosion Technology Information Exchange Conference and the Transportation Research Board (TRB) Annual Meeting and other TRB-designated forums. GTRI will seek patents on the filter system, and will seek a manufacturing partner to manufacture and market the filter systems.

DEVELOPMENT OF A SCREED TO DETECT AND MEASURE SEGREGATION OF HMA PAVEMENTS

NCHRP-IDEA Project 73

Mary Stroup-Gardiner [Tel.: (334) 844-6280; Fax: (334) 844-6290],
Auburn University, Auburn, Alabama

IDEA Concept and Product

The recently completed NCHRP Project 9-11, Segregation in Hot-Mix Asphalt Pavements (HMA), recommended the use of infrared thermography as one of two methods for specifying the detection and measurement of various levels of segregation during the construction of HMA pavements. This recommendation is based on the use of a hand-held infrared camera. However, the required technician testing time and initial capital investment are major road-blocks to the wide spread use of this methodology.

This project will develop an easily mounted screed attachment that will use a transverse line of infrared sensors, signal conditioners, and computer data acquisition system, and a position measurement system (e.g., global positioning system) to continuously monitor temperature differentials during construction (Figure 1). This will provide the contractor with a means of real-time process control to minimize segregation. Areas of non-uniformity indicated in the data files can then be located and additional testing performed at the discretion of the agency to determine if the level of segregation could reasonably be expected to be detrimental to pavement life.

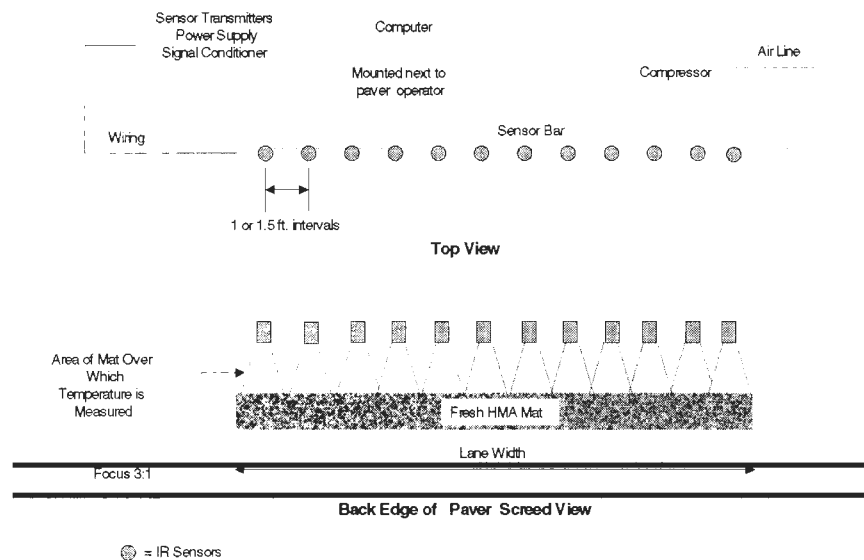

Figure 1

Schematic of proposed segregation screed.

Planned Investigation

The proposed research consists of two parts: the development of a prototype segregation screed, followed by preliminary field evaluations that will include a comparison with the infrared camera technology. The development of the prototype will include an investigation to optimize the horizontal and vertical sensor placement, selection of a position measurement system, and development of data acquisition and presentation software (in LabView). Field evaluations will be conducted on at least three projects using both the prototype screed and the infrared camera. These results will be used to calibrate the results presented by the segregation screed.

Product Payoff Potential

It is estimated that even a low level of segregation can cost agencies about 10 percent of the present worth of the original HMA. In extreme cases, a high level of segregation may result in cost of about 50 percent of the original cost. The potential for increasing the pavement life and minimizing repair and rehabilitation costs would easily generate savings of millions of dollars annually by agencies. A means of practically and economically collecting the required data and documentation would greatly improve the ability of states to implement the use of infrared technology to detect and measure segregation.

Product Transfer

The cooperative effort on this project between the National Center for Asphalt Technology (NCAT) and Astec, a manufacturer of HMA plants and construction equipment, provides an excellent means of making this new technology readily available to contractors and agencies alike.

ADHESION TOOL FOR OVERCOATING RISK-REDUCTION ANALYSIS

NCHRP-IDEA Project 74

James A. Ellor [Tel.: (703) 413-8266; Fax: (703) 413-8270],

Corrpro Companies Inc., Arlington, Virginia

and Gordon P. Bierwagen, North Dakota State University, Fargo, North Dakota

IDEA Concept and Product

The proposed IDEA program seeks to design and demonstrate a new and innovative adhesion test. The intent is to provide bridge owners with a process that will effectively evaluate an existing coating to determine its overcoat feasibility. Briefly, the overcoating adhesion tester will measure the existing coatings reaction to in-plane stress and its inherent ability to adhere to the substrate. The test gauge will replicate the stresses imparted from a new coating to the old coating in a worst-case scenario. Specifically, the gauge will simulate the stress incurred during the curing and mechanical movement of the new coating. The results will show quantitatively if the existing system may be overcoatable or not.

Planned Investigation

Our approach towards developing an improved adhesion test characterizing the suitability for overcoating will include:

- Brief literature review of supplemental data for the design of the stress experiments.
- Development of the lab test procedures. (see Figure 1 below for sample test setup).
- Characterization of the residual stress of alternative overcoat materials.
- Characterizing the stress limits of aged alkyd coatings through a prototype field-test.

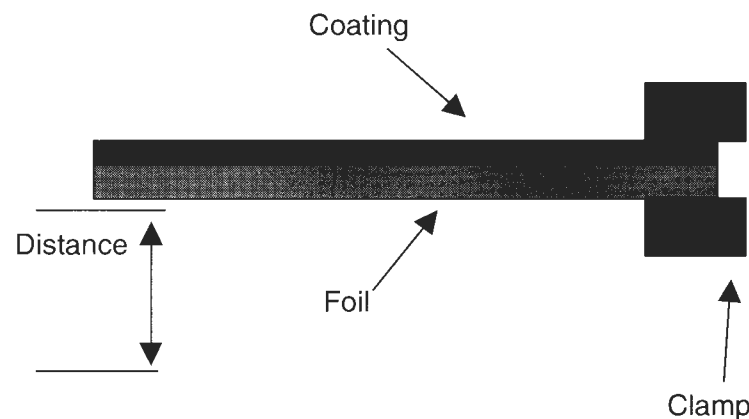

Figure 1

Sample lab test setup

Product Payoff Potential

Currently approximately 47% of all bridge maintenance-painting projects incorporate overcoating at half the cost of a full coating removal and replacement. We can increase the number of overcoating projects in the U.S. by providing a quantitative tool to determine the overcoatability of bridge structures. An increase of 20% in the number of overcoating projects could generate cost savings of \$2.2 billion.

Product Transfer

Laboratory and field tests will be utilized to qualify that the newly developed adhesion tester meets the goals of the program. The finalized prototype will then be designed for general manufacturing for mass distribution. Finally, a standard specification will be developed in conjunction with a national standardization body such as American Society for Testing of Materials (ASTM), National Association of Corrosion Engineers (NACE), Structural Steel Painting Council (SSPC) and ISO for proper use of the equipment and interpretation of the data.

AUTOMATED MOBILE HIGHWAY SIGN RETROREFLECTIVITY MEASUREMENT

NCHRP-IDEA Project 75

Norbert H. Maerz [Tel.: (573) 341-6714; Fax: (573) 341-4368], University of Missouri, Rolla, Missouri

IDEA Concept and Product

Techniques of image analysis will be developed to identify signs based on color characteristics, estimate the distance to each sign, and measure the retroreflectivity of the sign at the appropriate distance (Figure 1). This will all be done in real-time, in a vehicle driving at highway speeds, using the vehicle's own headlights for illumination. The system will be designed to be mounted in any suitable vehicle with inexpensive components such as an off-the-shelf computer, real-time digitizer, and a color camera (Figure 2).

When completed this inexpensive standalone system could be used to effectively and quickly measure the compliance of highway sign inventories with retroreflectivity standards. The system could be integrated with a GPS (global positioning system) and software could be developed to integrate the analysis results into an appropriate geographic information system (GIS) used for inventory management for state departments of transportation.

Planned Investigation

The investigation will consist of the following steps:

1. Implementation of a real-time mobile color image-capture system
2. Development of software to identify and characterize signs in the image window based on color and shape

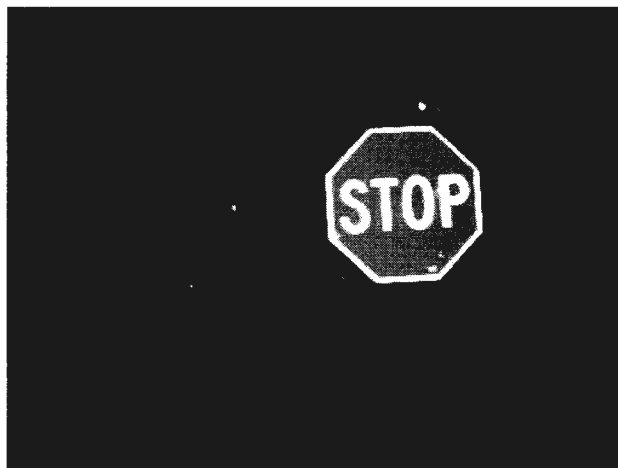

Figure 1

Traffic sign showing retroreflectivity

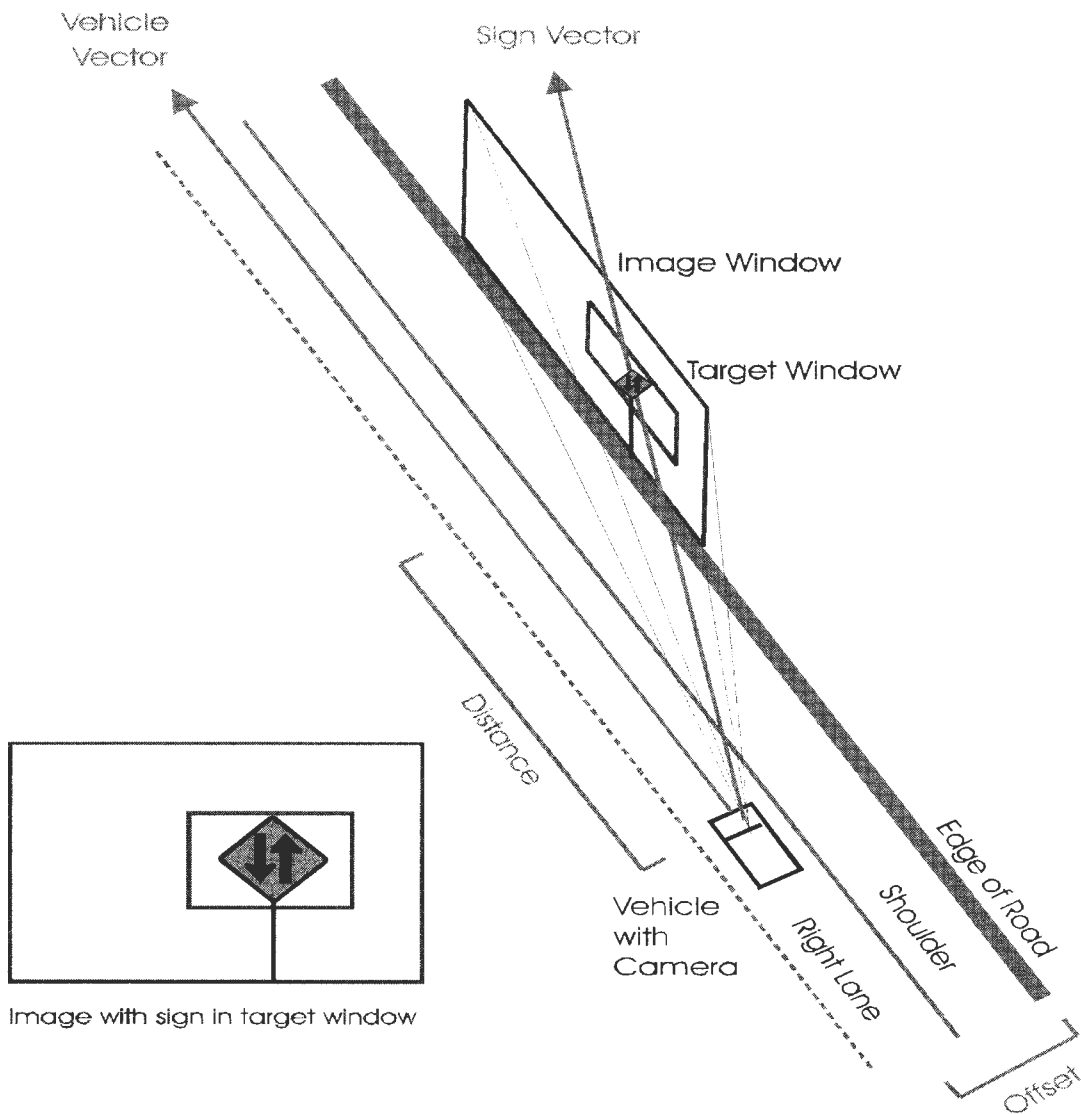

Figure 2

Geometry of the imaging process

3. Development of software to measure intensity of retroreflected light on the image
4. Calibration of measurements to manual (hand-held) retroreflectivity measurements
5. Determination of the linearity of the measurements
6. Calculation from the image of the approximate distance and angle of the sign relative to the vehicle at the time of imaging
7. Testing of the system with signs of varying of retroreflectivity
8. Development of a real-time system, with measurement result while the vehicle is traveling along the road.

Product Payoff Potential

This research will provide the tool to effectively measure the retroreflectivity of signs at a significantly lower cost, thus allowing better-informed management decisions on which signs need replacing. This new measurement tool will be more cost effective, making it available to contractors at a lower cost, and with lower unit measurement costs.

Hand-held measuring devices, labor- and cost-intensive by their very nature, are limited in the number of signs they can measure in a given time. The new measurement tool will allow more signs to be measured at a lower unit cost, with multiple measurements for each sign, increasing the statistical reliability of the measurement.

Product Transfer

Potential investors would be sought for the purpose of moving from a prototype to developing and marketing a final product.

SECTION 3 NSF/NRC-IDEA COOPERATIVE PROJECTS

The projects described in this section were funded jointly by the IDEA Program and the National Science Foundation (NSF) under a collaborative arrangement between NRC/TRB and NSF. The projects were funded in two separate yet interrelated parts. The basic science part (theoretical investigations and analytical verifications) was supported by an NSF grant, while the IDEA funds and contracts were used to develop and test the research product in a practical setting and to transfer results to highway applications.

CONTROL SYSTEM FOR HIGHWAY LOAD EFFECTS

NSF/NCHRP-IDEA Project 1

Andrzej S. Nowak [Tel: (313) 764-8495, Fax: (313) 764-4292],
University of Michigan, Ann Arbor, Michigan

The project developed and field tested an integrated monitoring system for highway load effects control (Figure 1). The system includes a weigh-in-motion (WIM) truck weight measurement, fatigue load spectra measurement, and failure detection systems. The integrated system coupled with analytical procedures (development of load spectra, component-specific diagnostic test, prediction of remaining fatigue life) was applied for monitoring and providing bridge loading diagnostics. The system proved to be effective on truck parameters (weight, axle loads, speed, lane position, multiple presence) and load effects (girder moments and shears, component-specific strain and stress, fatigue load spectra) for estimating the health and remaining life of the bridge.

The system has the potential to serve as an efficient control measure to monitor highway loads for bridge diagnostics (evaluation of site-specific bridge condition) and management. The results of this project are on the way to implementation by the Michigan Department of Transportation (MDOT). The project team works closely with the technical staff of MDOT. The field work was carried out on bridges selected in coordination with MDOT. Some of the most efficient results that have already been implemented include WIM measurements and proof load testing. The developed procedures have been used by MDOT for evaluation of selected partially deteriorated bridges. The investigators are extending the project to focus on developing a remote-sensing device for measuring lane-specific truck parameters to arrive at practical procedures for active and passive control of truck load effects and to improve prediction of life expectancy and reliability of bridge structures based on WIM measurement.

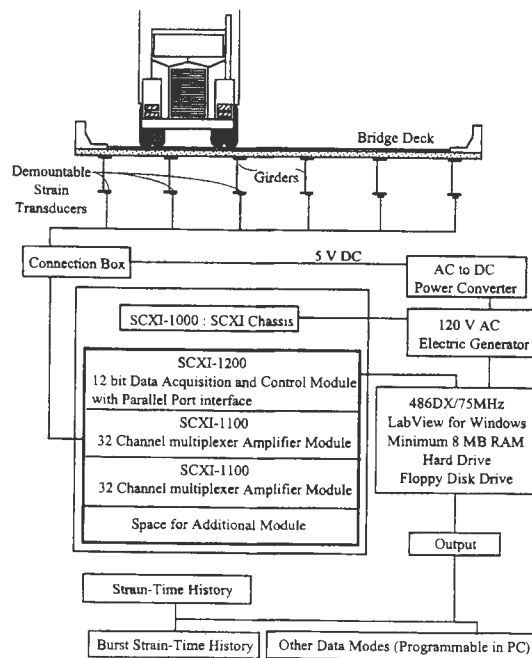

Figure 1

Data acquisition and control system.

PULSE-ECHO TOMOGRAPHIC MICROWAVE IMAGING SYSTEMS FOR QUANTITATIVE NDE OF CIVIL STRUCTURES AND MATERIALS

NSF/NCHRP-IDEA Project 2

Hua Lee [Tel: (805) 893-4480; Fax: (805) 893-3262], University of California, Santa Barbara, California

The objective of this research is to develop pulse-echo tomographic imaging techniques for quantitative nondestructive evaluation (NDE) of civil structures and materials. Pulse-echo impulse radar provides a means of detecting voids, cracks, and the condition of concrete reinforcement bars. The ability to recognize and identify the constitution of detected objects is also useful for NDE of civil structures. Classification of the material type permits the confirmation of design specifications and a more accurate evaluation of unknown areas.

Pulse-echo radar transmits a pulse and performs time-delay estimation on the received echoes to form the time-delay profile. A Fourier transform is used to decompose the returns into their frequency components. The frequency components are individually back-propagated to create a wavefield of the area. The wavefields are then superimposed to reconstruct the image area. A singular value decomposition of the wavefield at a target is used to generate a signature vector that minimizes the sum of all distances from each wavefield to its projection onto the vector. Signatures of different materials are stored in a database for comparison to the signatures of unidentified targets. Matches are performed by computing the magnitude of the inner product with each signature in the database. Objects are identified by matching multiple signatures from the target and applying majority rule.

The investigators successfully developed and implemented the image reconstruction algorithm for the data acquisition system and operating configuration. The utilization of wavefield statistics for accurate image formation was optimized and pattern recognition techniques were evaluated. Matching and recognition experiments were performed to demonstrate the application of the technique to evaluate civil structures.

Five classes of materials were used to test the object recognition method. The five targets included an air void, air permeated concrete, a full water occlusion, the air portion of an air/water mix, and the water portion of the air/water mix. All targets were embedded in concrete. The results showed that the technique identified all targets correctly. In fact, the object recognition scheme was able to correctly identify all classes of test objects with as few as 5 test set vectors.

The technique is being used in industrial applications at the Special Technologies Laboratories of the University of California, Santa Barbara. The California Department of Transportation is planning to use the technology in conjunction with the Lawrence Livermore National Laboratory system for bridge inspection. Cooperation for implementing the technology will be available from the NSF University/Industry Research Center on High-Speed Image Processing.

APPENDIX

Listing of IDEA Projects Awarded to Date in ITS-IDEA, Transit-IDEA, and High-Speed Rail-IDEA Programs.

ITS-IDEA Projects

- ITS-1: University of Michigan, Ann Arbor, Michigan - *“Collision Avoidance and Improved Traffic Flow Using Vehicle-to-Vehicle Communication”* - (Bernard Galler, Principal Investigator)
- ITS-2: Purdue University, West Lafayette, Indiana - *“Models for Real-Time Incident Prediction”* - (S. Madanat, Principal Investigator)
- ITS-3: CF International, Reno, Nevada - *“Improved Metropolitan Area Transportation Systems (IMATS): Carpooling and Computerized Vehicle Dispatching in Association with a Vehicle Rental System”* - (John Chisholm, Principal Investigator)
- ITS-4: Louisiana State University, Baton Rouge, Louisiana - *“A Distributed Input/Output Subsystem for Traffic Signal Control”* - (Darcy Bullock, Principal Investigator)
- ITS-5: Auburn University, Auburn, Alabama - *“Feasibility Study of IVHS Drifting Out of Lane Alert System”* - (Ed Ramey, Principal Investigator)
- ITS-6: Schwartz Electro-Optics, Inc., Orlando, Florida - *“Laser-Based Vehicle Detector/Classifier”* - (Richard Wangler, Principal Investigator)
- ITS-7: Honeywell Technology Center, Minneapolis, Minnesota - *“Driver-Adaptive Warning System”* - (Chris Miller, Principal Investigator)
- ITS-8: SUNY at Stony Brook, Stony Brook, New York - *“Laser Optics Open-Air Communication System”* - (Sheldon Chang, Principal Investigator)
- ITS-9: University of Michigan, Ann Arbor, Michigan - *“Decision-Theoretic Reasoning for Traffic Monitoring and Vehicle Control”* - (Michael Wellman, Principal Investigator)
- ITS-11: SRI International, Menlo Park, California - *“Scale-Model AHS Research Facility (SMARF)”* - (Raul Vera, Principal Investigator)
- ITS-12: Compuline, Inc., La Jolla, California - *“Vehicle Lane Control System”* - (Bill Bush, Principal Investigator)
- ITS-13: University of Washington, Seattle, Washington - *“Development of an Intelligent Air Brake Warning System for Commercial Vehicles”* - (Per Reinhall, Principal Investigator)
- ITS-14: Christian Brothers University, Memphis, Tennessee - *“Adaptive Filtering for ITS and Advanced Vehicle Control”* - (Laura Ray, Principal Investigator)
- ITS-15: Purdue University, West Lafayette, Indiana - *“Efficient Use of Narrowband Radio Channels for Mobile Digital Communications”* - (Michael Fitz, Principal Investigator)
- ITS-16: University of California, Berkeley, California - *“Engineered Visibility Warning Signals: Tests of Time to React, Detectability, Identifiability and Salience”* - (Ed Cohn, Principal Investigator)
- ITS-17: Purdue University, West Lafayette, Indiana - *“Sequential Hypothesis Testing-Based Decision-Making System for Freeway Incident Response”* - (S. Madanat, Principal Investigator)
- ITS-18: Northrop-Grumman Corp., Pico Rivera, California - *“Three-in-One Vehicle Operator Sensor”* - (Rick Hamlin, Principal Investigator)
- ITS-19: The Analytic Sciences Corp. (TASC), Reading, Massachusetts - *“AutoAlert: Automated Acoustic Detection of Traffic Incidents”* - (Dave Whitney, Principal Investigator)

- ITS-20: National-Louis University, Oak Park, Illinois - "*Real Time, Computer-Matched Ridesharing Using Cellular or Personal Communications Services (RTCMR/PCS)*" - (Ed Walbridge, Principal Investigator)
- ITS-21: Northrop-Grumman Corp., Rolling Meadows, Illinois - "*Interference-Resistant Signals for Collision Avoidance Radar*" - (Mark Hischke, Principal Investigator)
- ITS-23: Johns Hopkins University, Laurel, Maryland - "*GPS Drain: Demonstration of Precise Navigation for Vehicle Collision Avoidance*" - (Mark Asher, Principal Investigator)
- ITS-24: Swales and Associates, Inc., Huntsville, Alabama - "*Passive Optical Lane Position Monitor*" - (Joseph Geary, Principal Investigator)
- ITS-25: Eaton Corp., Southfield, Michigan - "*Automated Roadside Brake Inspection Concept Evaluation*" - (Thomas Wissing, Principal Investigator)
- ITS-26: University of Delaware, Newark, Delaware - "*Fuzzy Inference Based Driver Decision Process and Traffic Flow Simulator*" - (Sinya Kikuchi, Principal Investigator)
- ITS-27: University of Illinois at Chicago, Chicago, Illinois - "*Application of Neural Networks to Data Fusion: A Feasibility Study*" - (Peter Nelson, Principal Investigator)
- ITS-28: University of Michigan, Ann Arbor, Michigan - "*Development and Evaluation of Communication Requirements for Low-Cost Network-Based Driving Sensors for ITS Safety Research*" - (Paul Green, Principal Investigator)
- ITS-29: Waveband Corp., Torrance, California - "*Innovative Scanning Antenna Systems for Advanced Recognition of Rail Collision, Obstacle Detection, and Automobile Collision Avoidance*" - (Lev Sadovnik, Principal Investigator)
- ITS-30: Intelligent Highway Systems, Inc., White Plains, New York - "*Vehicle Detection and Tracking from a Wide Angle Sensor's Video Signal for Intersection Control and Intelligence*" - (Eugene Waldenmaier, Principal Investigator)
- ITS-32: Northrop-Grumman Corp., Rolling Meadows, Illinois - "*National Coverage for Emergency Mayday Systems*" - (Dave Richardson, Principal Investigator)
- ITS-33: Ohio State University, Columbus, Ohio - "*Radar-Based Convoying Using a Frequency Selective Surface Patch for Trucks, Railroads, and AHS*" - (Umit Ozguner, Principal Investigator)
- ITS-34: Nichols Research Corp., Arlington, Virginia - "*Remote Passive Road Ice Sensor System (RPRISS)*" - (Jack Reed, Principal Investigator)
- ITS-35: DVP, Inc., Rockville, Maryland - "*An Expert System-Based Diagnostic Instrument for IVHS Maintenance Operations*" - (Boris Donskoy, Principal Investigator)
- ITS-36: University of Michigan, Ann Arbor, Michigan - "*Application of Decision Analysis to ITS Societal Issues*" - (Barbara C. Richardson, Principal Investigator)
- ITS-38: Fiber and Sensor Technologies, Inc., Blacksburg, Virginia - "*Fiber Optic Visibility Sensor System*" - (Richard O. Claus, Principal Investigator)
- ITS-40: Oregon State University, Corvallis, Oregon - "*Application of Ergonomic Guidelines for APTS Technology to Practice*" - (Katharine Hunter-Zaworski, Principal Investigator)
- ITS-41: QST Electronics, Inc., La Jolla, California - "*Resonant Loop Lane Control*" - (E. William Bush, Principal Investigator)
- ITS-42: Quantics, San Diego, California - "*Anti-Glare Device Using Photochromic Focal Plane*" - (George S. Levy, Principal Investigator)
- ITS-43: Weissman Science & Engineering Co., Washington, D.C. - "*Feasibility Study for a Regional Traffic Surveillance Concept*" - (Isaac Weissman, Principal Investigator)
- ITS-44: National Institute of Statistical Sciences, Raleigh, North Carolina - "*Integration of Empirical Models of Vehicle Emissions Within Advanced Traffic Management Systems*" - (Nagui Roupail, Principal Investigator)

- ITS-45: University of Utah, Salt Lake City, Utah - "*Automated Roadway Avalanche Hazard Reduction: An Intelligent Transportation System for Rural Winter Transit*" - (Rand Decker, Principal Investigator)
- ITS-47: Purdue University, West Lafayette, Indiana - "*A Spectrally Efficient Wireless Modem for ITS Applications*" - (Michael P. Fitz, Principal Investigator)
- ITS-48: CF International, Reno, Nevada - "*Instant Rent-A-Car Technology Applied to Transit Station Car Practice*" - (John Chisholm, Principal Investigator)
- ITS-49: Purdue University, West Lafayette, Indiana - "*Travel Time Prediction in Intelligent Transportation Systems*" - (Andrzej P. Tarko, Principal Investigator)
- ITS-50: Physical Sciences, Inc., Andover, Massachusetts - "*Road Surface Condition Detection and Monitoring Technology for a Vehicle-Mounted Hazard Warning System*" - (Prakash Joshi, Principal Investigator)
- ITS-51: Pennsylvania State University, University Park, Pennsylvania - "*Development of Risk Factor Reduction Guidelines to Facilitate Participation, Deployment, and Operations in ITS*" - (John Bagby, Principal Investigator)
- ITS-52: DVP, Inc., Rockville, Maryland - "*An Advanced Diagnostic Instrument for Inductive Loop System Maintenance*" - (Boris Donskoy, Principal Investigator)
- ITS-53: University of Utah, Salt Lake City, Utah - "*A Real-Time Flow Estimation Model for Advanced Urban Traffic Control*" - (Peter Martin, Principal Investigator)
- ITS-56: ERIM, Ann Arbor, Michigan - "*Snow and Ice Removal Monitoring and Management System Project*" - (Paul K. Zoratti, Principal Investigator)
- ITS-57: University of Michigan, Ann Arbor, Michigan - "*Differential Braking for Limited-Authority Lateral Maneuvering to Support Active Safety Systems*" - (Robert Ervin, Principal Investigator)
- ITS-60: Sensor Technologies & Systems Inc., Scottsdale, Arizona - "*Visibility Monitoring System*" - (Terry Wilson, Principal Investigator)
- ITS-61: University of California, Los Angeles, California - "*IRIS: Intelligent Ranging with Infrared Sensors*" - (Ioannis Kanellakopoulos, Principal Investigator)
- ITS-62: University of Massachusetts, Dartmouth, Massachusetts - "*Wavelet-Based Image Compression and Analysis System for ITS*" - (C.H. Chen, Principal Investigator)
- ITS-63: Midland Associates, Inc., Minneapolis, Minnesota - "*Electronic Safety System for Emergency Vehicles*" - (Douglas Maxwell, Principal Investigator)
- ITS-65: Schwartz Electro-Optics, Inc., Orlando, Florida - "*Improved Vehicle Classification Using an Overhead Imaging Lidar System with Axle Counting Capability*" - (Robert Gustavson, Principal Investigator)
- ITS-66: Multispectral Solutions, Inc., Gaithersburg, Maryland - "*Use of Ultra Wideband (UWB) Technology for Designated Short Range Communications (DSRC)*" - (Robert Fontana, Principal Investigator)
- ITS-69: KLD Associates, Inc., Huntington Station, New York - "*Real-Time Traffic Control of Over-Saturated Conditions*" - (Edward Lieberman, Principal Investigator)
- ITS-71: Kaman Sciences Corp., Colorado Springs, Colorado - "*Real-Time Signal Control Using Queue Length Information Deployed at an Intersection*" - (Robert Larson, Principal Investigator)
- ITS-72: University of California, Irvine - "*Algorithms for Carrier Fleet Operations Demand Responsive Services for Standard Ground and Intermodal Freight Movements*" - (Amelia C. Regan, Principal Investigator)
- ITS-73: The Centre for Education and Research in Safety, Cambridge, Massachusetts - "*Animated LED 'Eyes' Traffic Signals*" - (Ron Van Houten, Principal Investigator)

- ITS-74: Lexington Consulting, Cambridge, Massachusetts - *“Data Communications for Remote Sensors Using ReFLEX Narrowband PCS Technology”* - (Sudhir Murthy, Principal Investigator)
- ITS-75: University of Washington - *“Data Communications for Remote Sensors Using ReFLEX Narrowband PCS Technology”* - (Per Reinhall, Principal Investigator)
- ITS-76: University of California at Berkeley - *Inexpensive Inertial Navigation System with GPS-Based Attitude Determination* (Principal Investigator: Pravin Varaiya)
- ITS-77: Sri International, Menlo Park, California - *Inexpensive Inertial Navigation System (Ins) With Gps-Based Attitude Determination* (Principal Investigator: Randy Galijan, Other participants: University of California at Berkeley)
- ITS-78: Utah State University, Logan - *Simulation Model For Evaluating Traffic Management Strategies On Intermodal Passenger Terminal Access Roadway Systems* (Principal Investigator: Prianka Seneviratne)
- ITS-79: Weather Solutions Group, Chesterfield, Missouri - *Roadway Flash Flood Warning Devices – Feasibility Study* (Principal Investigator: Edward Boselly)
- ITS-80: Minnesota Department of Transportation, St. Paul - *Snowplow Operator Assist System* (Principal Investigators: Marthand Nookala and Stephen Bahler, Other Participants: University of Minnesota, 3M, Altra Technologies, Booz-Allen and Hamilton)
- ITS-82: University of Colorado at Denver - *Modeling Bicycles in Traffic for Advanced Traffic Management and Control* (Principal Investigator: Sarosh Khan)
- ITS-83: Connecticut Analytical Corporation, Bethany - *Deceleration Warning System for Commercial Vehicles* (Principal Investigator: Joseph Bango, Jr.)
- ITS-84: I-Witness Inc., San Diego, California - *I-Witness Black Box Recorder*, (Principal Investigators: Gary Rayner and Sophia Rayner)
- ITS-85: Physical Sciences Inc., Andover, Massachusetts - *A Mobile Road Condition Sensor as Winter Maintenance Aid* (Principal Investigator: Prakash Joshi)
- ITS-86: *A 220MHz Modem for ITS: The Final Step to Deployment* (Principal Investigators: Bjorn Bjerede, Welkin Systems Inc., San Diego, California and Michael Fitz, Ohio State University, Columbus)

Transit-IDEA Projects

- Transit-1: Tri-County Metropolitan Transportation District of Oregon, Portland, Oregon - *“Customer Satisfaction Index for the Mass Transit Industry”* - (Kathryn Coffel, Principal Investigator)
- Transit-2: Bay Area Rapid Transit District, Oakland, California - *“Adaptive Diagnostic System Project”* - (Steven Mullerheim, Principal Investigator)
- Transit-3: International Electronic Machines Corp., Albany, New York - *“Automatic Wheel Inspection Station”* - (Zahid Mian, Principal Investigator)
- Transit-4: Northeastern University, Boston, Massachusetts - *“Management Information Benefits of On-Board Integration of Electronic Fareboxes”* - (Peter Furth, Principal Investigator)
- Transit-5: Greneker and Associates, Inc., Marietta, Georgia - *“Improved Passenger Counter and Classification System for Transit Applications”* - (E. F. Greneker, Principal Investigator)
- Transit-7: Baylor College of Medicine, Houston, Texas - *“Wheelchair Restraint System”* - (Thomas Krouskop, Principal Investigator)
- Transit-8: Transcom International Ltd., Winnipeg, Manitoba, Canada - *“Real-Time Transit Data Broadcast”* - (Edward Burgener, Principal Investigator)

- Transit-9: Southern Maine Areas Agency on Aging, Portland, Maine - *"The Independent Transportation Network: Alternative Transportation for the Elderly"* - (Katherine Freund, Principal Investigator)
- Transit-10: Advanced Systems Group International, Herndon, Virginia - *"Automatic Data Collection on Transit Users via Radio Frequency Identification"* - (Stephen Briggs, Principal Investigator)
- Transit-11: San Francisco Municipal Railway, San Francisco, California - *"Compact Disc, Interactive Violence Prevention Training Program"* - (Debi Horen, Principal Investigator)
- Transit-12: Vertical Systems, Inc., Bellevue, Washington - *"Transit and Intermodal Scheduling Using Expert Systems"* - (David Muchmore, Principal Investigator)
- Transit-13: TransTech Management, Wayland, Massachusetts - *"Interactive PC-Based Track Safety Training"* - (Daniel Mesnick, Principal Investigator)
- Transit-14: CF International, Reno, Nevada - *"Instant Rent-A-Car Technology Applied to Transit Station Car Practice"* - (John Chisholm, Principal Investigator)
- Transit-15: Kiernan Transit Associates, Lafayette, California - *"Internet Information Sharing for Transit Maintenance (TranspoNet)"* - (Victor D. Kiernan, Principal Investigator)
- Transit-16: The Cleveland Clinic Foundation, Cleveland, Ohio - *"Transit Restraint System for Wheel Chairs"* - (Steven Roger, Principal Investigator)
- Transit-17: International Electronic Machines Corp., Albany, New York - *"Operational Evaluation of Rail Based Wheel Gauge Inspection System"* - (Zahid Mian, Principal Investigator)
- Transit-18: Independent Transportation Network, Portland, Maine - *"Pilot Testing Innovative Payment Operations for Independent Transportation for the Elderly"* - (Katherine Freund, Principal Investigator)
- Transit-19: University of Virginia, Charlottesville, Virginia - *"Field Testing and Evaluation of the Transit Integrated Monitoring System"* - (Manuel D. Rossetti, Principal Investigator)
- Transit-20: Greneker and Associates, Inc., Marietta, Georgia - *"Non-Contact Sensor for Passenger Counting and Classification"* - (Gene Greneker, Principal Investigator)
- Transit-21: Oregon State University, Corvallis, Oregon - *"Smart Parking Lot with Just-in-Time Bus Service"* - (Chris A. Bell, Principal Investigator)
- Transit-22: Arthur D. Little, Inc., Cambridge, Massachusetts - *"Sleeved Column System for Crash Worthiness of Light Rail Vehicles"* - (Ronald Mayville, Principal Investigator)
- Transit-23: Washington University, St. Louis, Missouri - *"Optimizing Travel Path for People with Disabilities"* - (W. Davis van Bakergem, Principal Investigator)
- Transit-24: Tranergy Corporation, Bensenville, Illinois - *"Operational Testing of Innovative and Intelligent Rail Lubrication System"* - (Sudhir Kumar, Principal Investigator)
- T-25: SYSTAN, Inc. - *Operating Policies for Improved Transit Productivity* (Principal Investigator: Roy Lave)
- T-26: Ultimate Technologies - *Designing Transit Services for the Mode-Choice Market, Stage III: Planning Tools and Processes* (Principal Investigator: Alan Hoffman)
- T-27: Columbia University - *Gap Guard* (Principal Investigator: Richard J. Muller)

HSR-IDEA Projects

- HSR-1: Waveband Corp., Torrance, California - *"Innovative Scanning Antenna Systems for Advanced Recognition of Rail Collision, Obstacle Detection, and Automobile Collision Avoidance"* - (Lev Sadovnik, Principal Investigator)

- HSR-2: Intelligent Highway Systems, White Plains, New York - "*Vehicle Detection and Tracking from a Wide Angle Sensor's Video Signal for Intersection Control and Intelligence*" - (Eugene Waldenmaier, Principal Investigator)
- HSR-3: SUNY at Stony Brook, Stony Brook, New York - "*Assessment of Laser Optics Open-Air Communication System for Railroads and Highways*" - (Sheldon Chang, Principal Investigator)
- HSR-5: Pulse Electronics, Inc., Rockville, Maryland - "*Enhanced Proximity Warning System*" - (Robert C. Kull, Principal Investigator)
- HSR-6: Intelligent Highway Systems, White Plains, New York - "*Demonstration and Testing of IHS Wide Field Surveillance System Integration with the Highway and Railway Infrastructure*" - (Eugene Waldenmaier, Principal Investigator)
- HSR-7: Relume Corp., Troy, Michigan - "*Pulsed LED Railroad Crossing Signals*" - (Peter A. Hochstein, Principal Investigator)
- HSR-8: O'Conner Engineering, Inc., Benicia, California - "*Remote Sensing Advance Warning Systems Test Project*" - (Joe O'Conner, Principal Investigator)
- HSR-9: Foster-Miller, Inc., Waltham, Massachusetts - "*Single Arm Folding Extension*" - (Peter Warren, Principal Investigator)
- HSR-10: Nestor, Inc., Providence, Rhode Island - "*A Neural Network Video Sensor Application for Rail Crossing Safety*" - (Douglas Reilly, Principal Investigator)
- HSR-11: Rail Safety Engineering, Inc., Rochester, New York - "*Quad Gate Crossing System*" - (David Rutherford, Principal Investigator)
- HSR-12: Aspen Systems, Inc., Marlborough, Massachusetts - "*Fiberoptic Relayed Laser Radar for Railroad Transportation*" - (Kannan Krishnaswami, Principal Investigator)
- HSR-13: Waveband Corp., Torrance, California - "*Development of a Highway-Railroad Grade-Crossing Obstacle Detection Radar*" - (Vladimir Manasson, Principal Investigator)
- HSR-14: ENSCO, Inc. - "*Low-Cost Multiple Inertial Measurement for Locomotive Navigation*" (Principal Investigator: Fred Riewe)
- HSR-15: University of Utah - "*Development of a Hybrid Uni-Axial Strain Transducer to Periodically Monitor Transportation Infrastructure*" (Principal Investigator: Hosin Lee)
- HSR-16: Texas Transportation Institute - "*Advanced Train Detection for Preemption of Highway Traffic Controllers*" (Principal Investigator: Steven Venglar)
- HSR-17: Raven, Inc. - "*Automatic Flagging System for Track Maintenance Workers*" (Principal Investigator: James Genova)
- HSR-18: Texas Transportation Institute - "*An Investigation into the Use of Buried Fiber Optic Filament to Detect Trains and Broken Rail*" (Principal Investigator: Stephen Roop)
- HSR-19: University of Illinois - "*Fiber Optic Sensors for High-Speed Rail Applications*" (Principal Investigator: S.L. Chuang)
- HSR-20: Fraunhofer Resource Center - "*Metal Foams for Safety Improvement*" (Principal Investigator: Harald Eifert)

THE NATIONAL ACADEMIES

Advisers to the Nation on Science, Engineering, and Medicine

National Academy of Sciences
National Academy of Engineering
Institute of Medicine
National Research Council

The Transportation Research Board is a unit of the National Research Council, which serves the National Academy of Sciences and the National Academy of Engineering. The Board's mission is to promote innovation and progress in transportation by stimulating and conducting research, facilitating the dissemination of information, and encouraging the implementation of research results. The Board's varied activities annually engage more than 4,000 engineers, scientists, and other transportation researchers and practitioners from the public and private sectors and academia, all of whom contribute their expertise in the public interest. The program is supported by state transportation departments, federal agencies including the component administrations of the U.S. Department of Transportation, and other organizations and individuals interested in the development of transportation.

The National Academy of Sciences is a private, nonprofit, self-perpetuating society of distinguished scholars engaged in scientific and engineering research, dedicated to the furtherance of science and technology and to their use for the general welfare. Upon the authority of the charter granted to it by the Congress in 1863, the Academy has a mandate that requires it to advise the federal government on scientific and technical matters. Dr. Bruce M. Alberts is president of the National Academy of Sciences.

The National Academy of Engineering was established in 1964, under the charter of the National Academy of Sciences, as a parallel organization of outstanding engineers. It is autonomous in its administration and in the selection of its members, sharing with the National Academy of Sciences the responsibility for advising the federal government. The National Academy of Engineering also sponsors engineering programs aimed at meeting national needs, encourages education and research, and recognizes the superior achievements of engineers. Dr. William A. Wulf is president of the National Academy of Engineering.

The Institute of Medicine was established in 1970 by the National Academy of Sciences to secure the services of eminent members of appropriate professions in the examination of policy matters pertaining to the health of the public. The Institute acts under the responsibility given to the National Academy of Sciences by its congressional charter to be an adviser to the federal government and, upon its own initiative, to identify issues of medical care, research, and education. Dr. Kenneth I. Shine is president of the Institute of Medicine.

The National Research Council was organized by the National Academy of Sciences in 1916 to associate the broad community of science and technology with the Academy's purposes of furthering knowledge and advising the federal government. Functioning in accordance with general policies determined by the Academy, the Council has become the principal operating agency of both the National Academy of Sciences and the National Academy of Engineering in providing services to the government, the public, and the scientific and engineering communities. The Council is administered jointly by both the Academies and the Institute of Medicine. Dr. Bruce M. Alberts and Dr. William A. Wulf are chairman and vice chairman, respectively, of the National Research Council.

TRANSPORTATION RESEARCH BOARD
NATIONAL RESEARCH COUNCIL

NATIONAL ACADEMY PRESS
Washington, DC 2001

MTA DOROTHY GRAY LIBRARY & ARCHIVE



1000000276178

ation Research Board
Research Council
stitution Avenue, N.W.
on, D.C. 20418

Correction Requested

Non Profit Org
US Postage
PAID
Washington, DC
Permit # 8970

007168-00 IDEA-HWY
MR KEITH L KILLDOUGH
DEPUTY EXECUTIVE OFFICER
LOS ANGELES COUNTY MTA
MS 99-23-7
1 GATEWAY PLZ
LOS ANGELES CA 90012-2952

7 P5

